

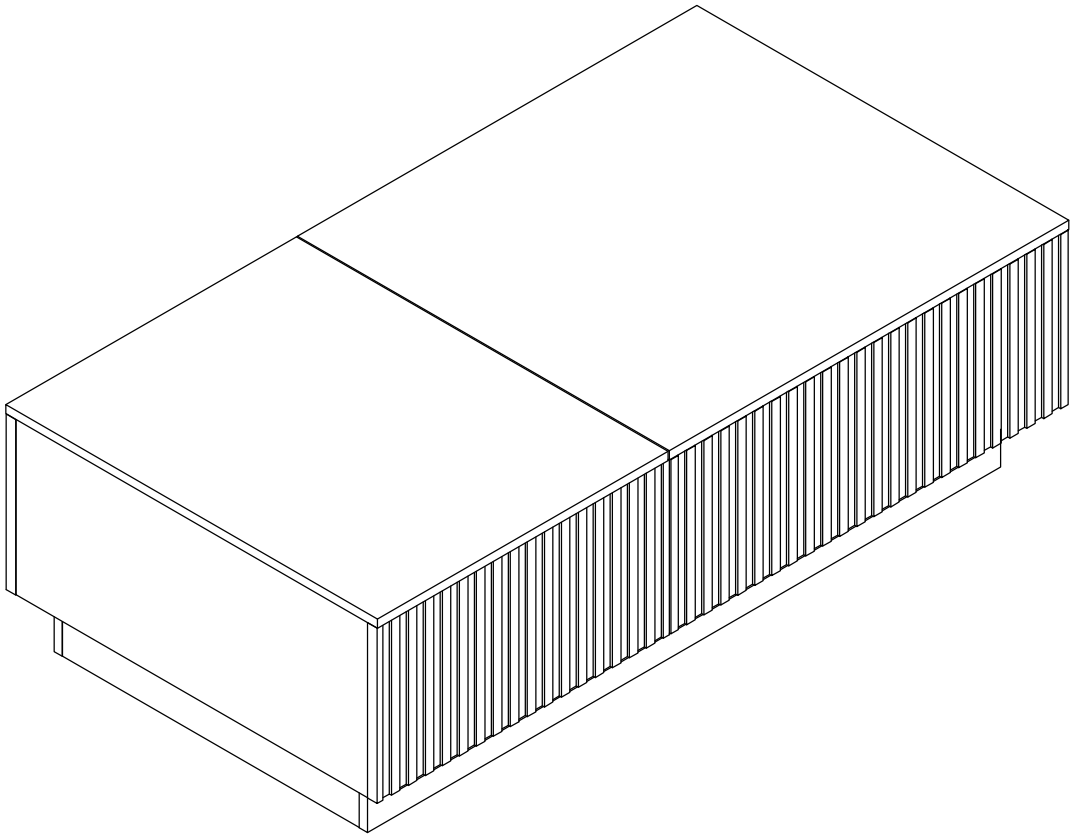

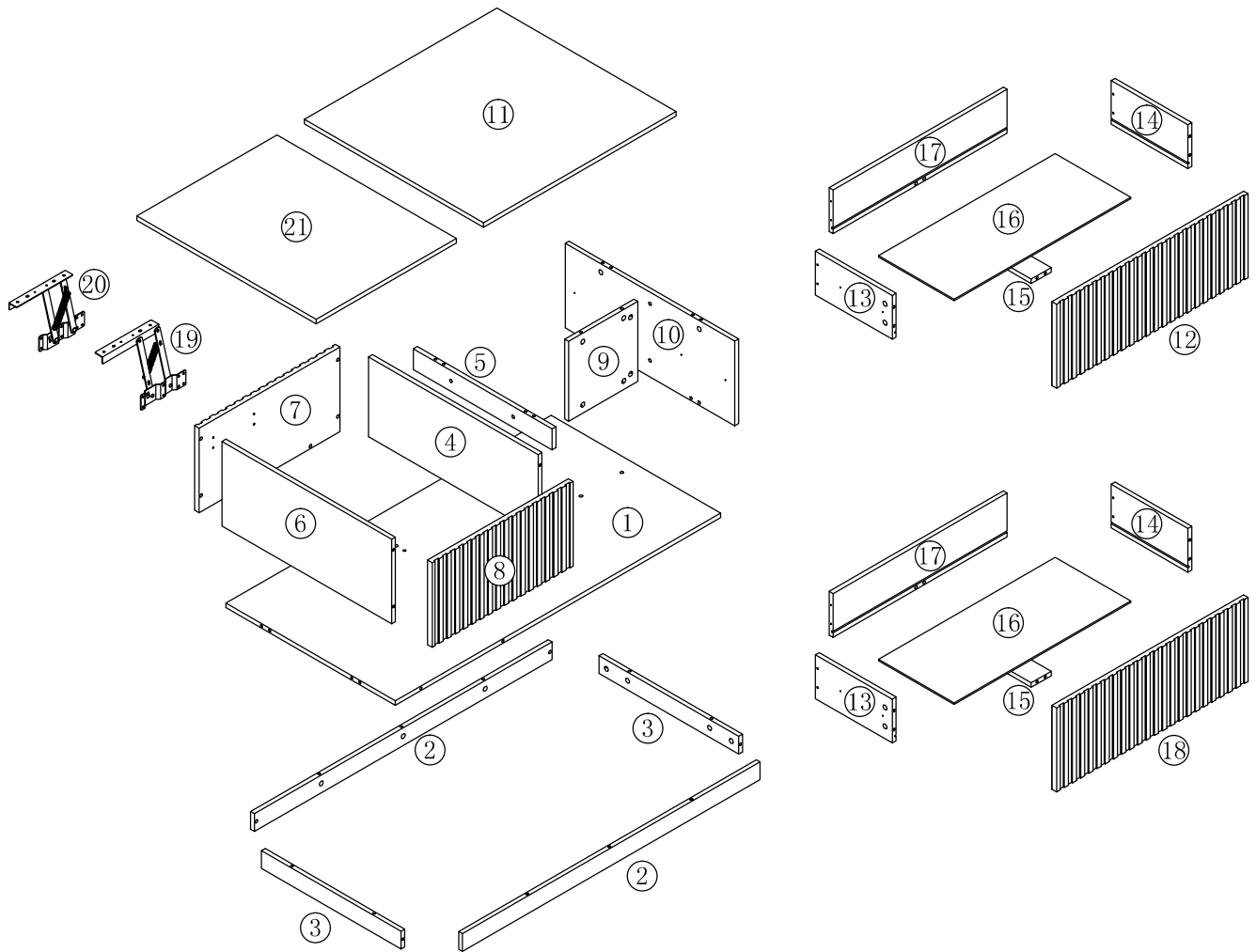

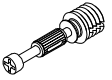

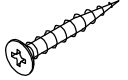

Coffee table

Installation Instructions

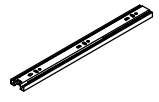

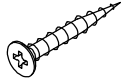

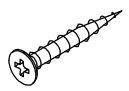
A	58PCS	B	58PCS	C	48PCS	D	6PCS	F	4PCS
									
Ø6*35mm		Ø15*10mm		Ø3.5*14mm		M6		12"	
G	10PCS	H	8PCS	I	4PCS	J	12PCS		
									
Ø8*30mm		Ø3.5*40mm		M6*12mm		Ø5*14mm			

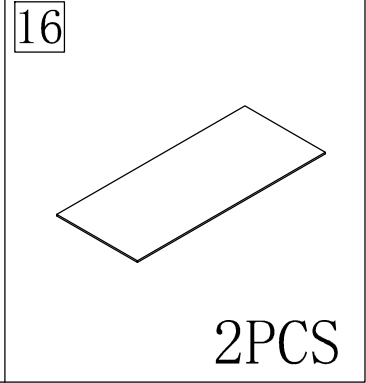
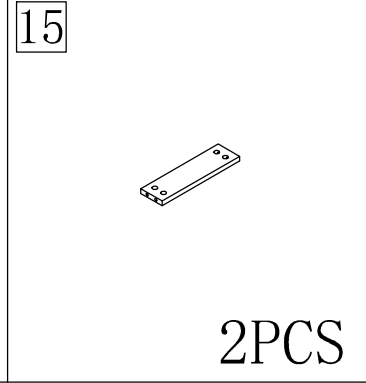
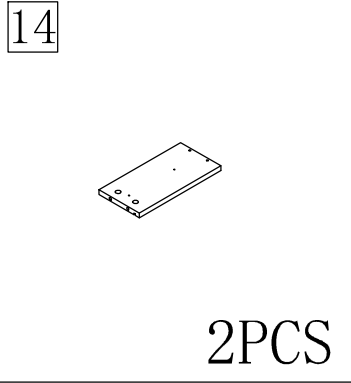
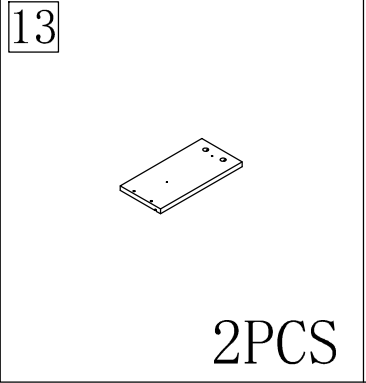
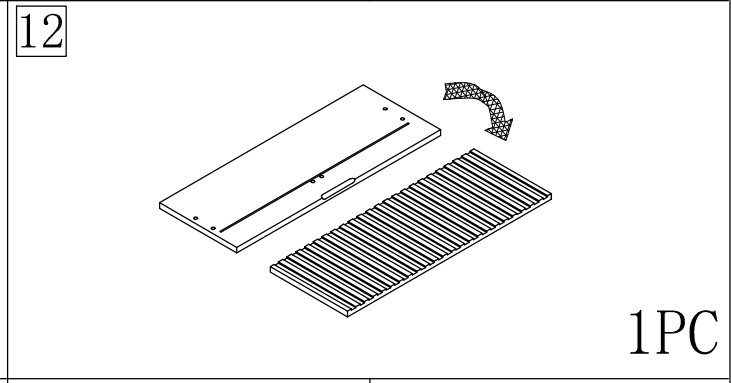
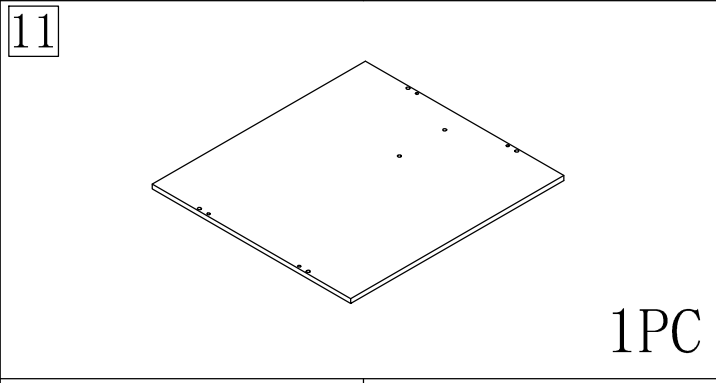
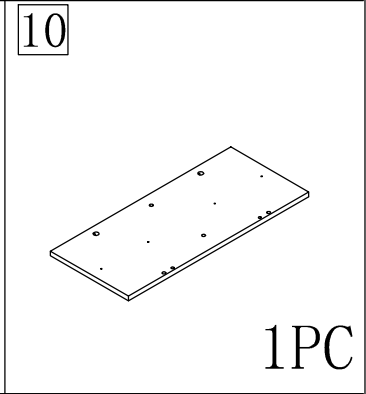
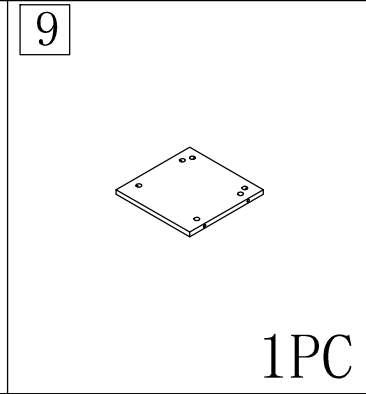
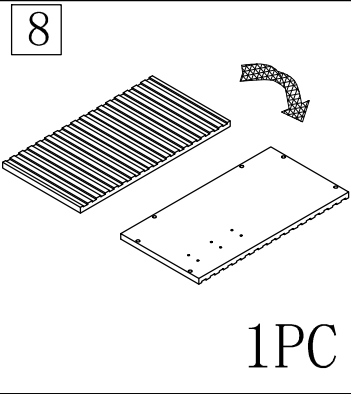
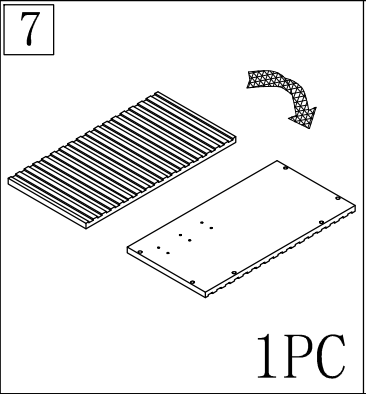
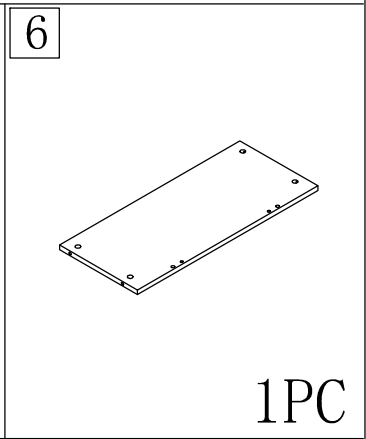
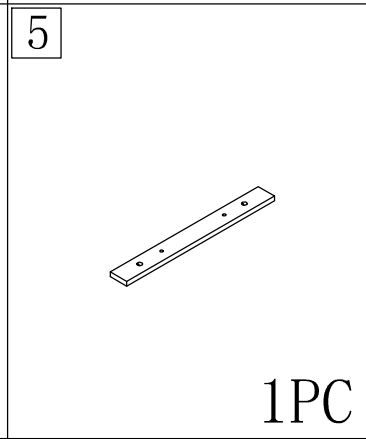
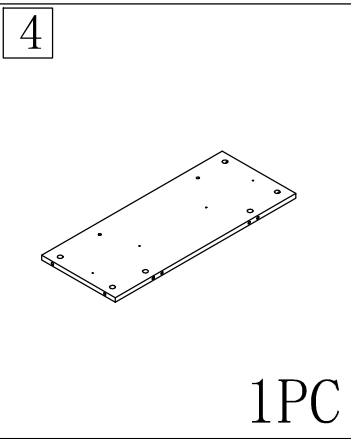
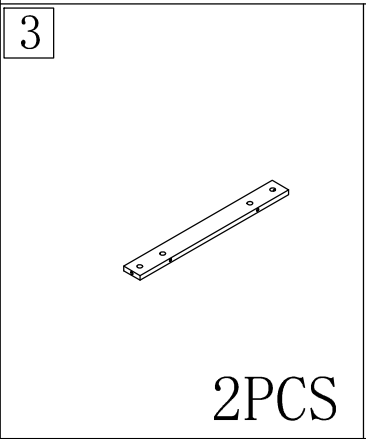
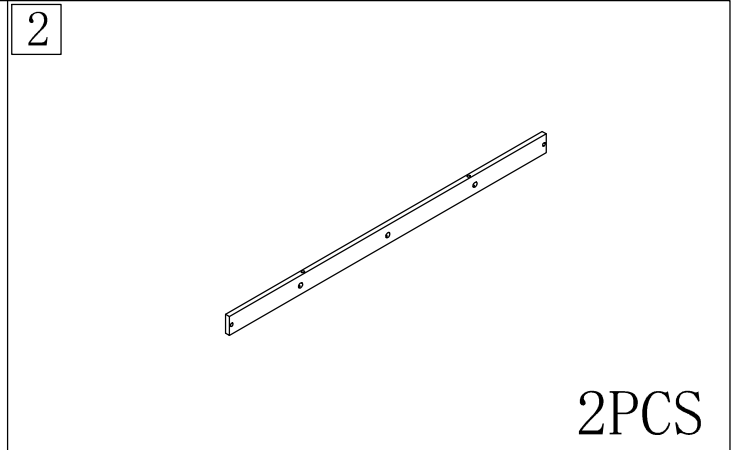
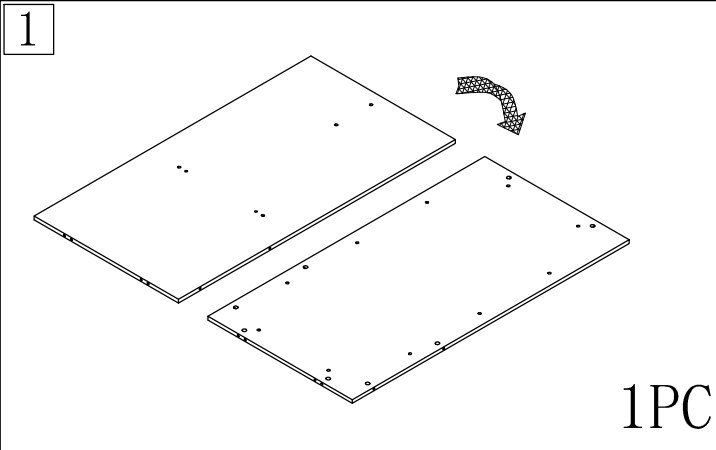

17

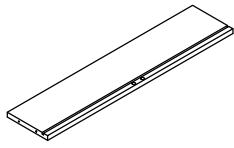

2PCS

18

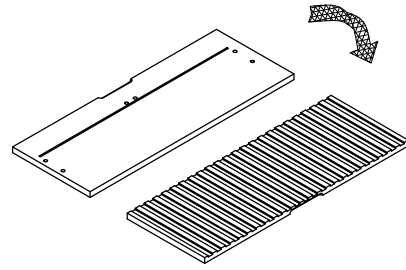

1PC

19



1PC

20



1PC

21

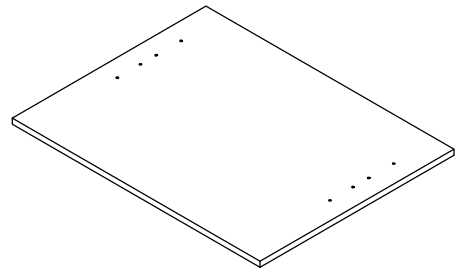

1PC

"A" Hardware installation example

I

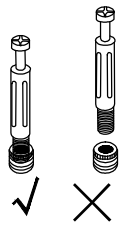

This part cannot be separated, please install in strict accordance with the assembly requirements

II

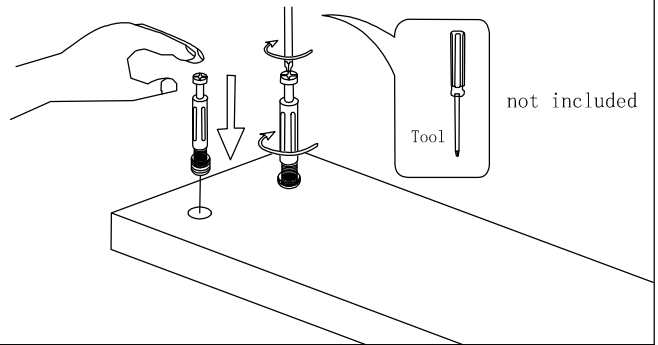

III

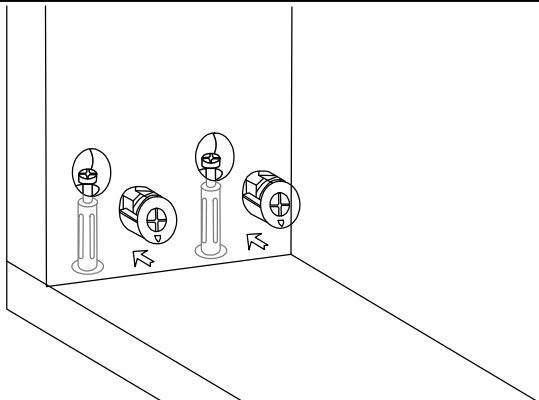

IV

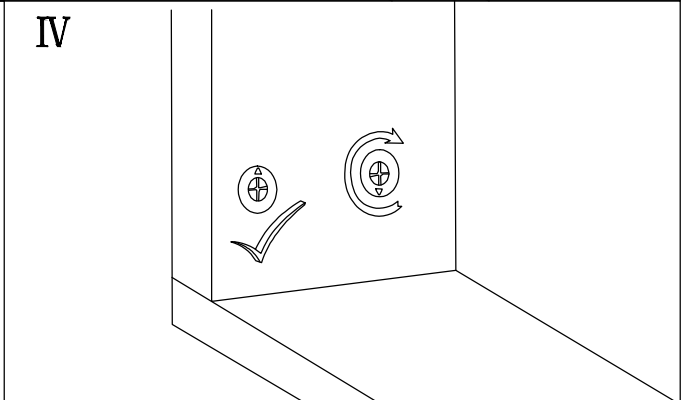

Step 1

A 58PCS

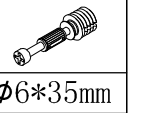

Ø6*35mm

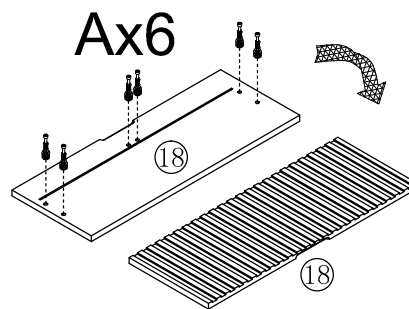
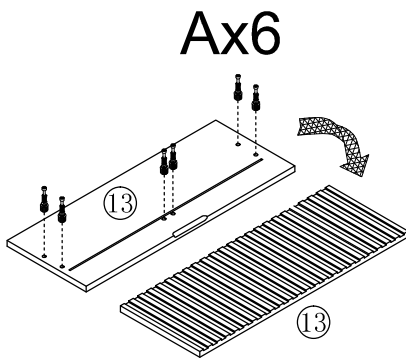
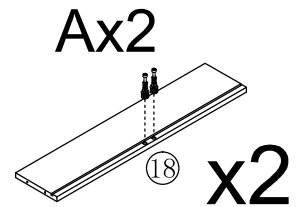
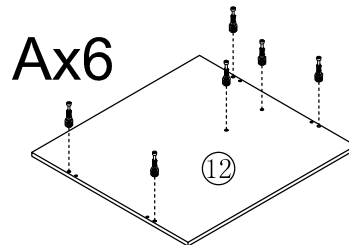
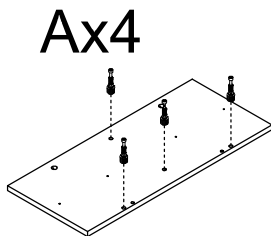
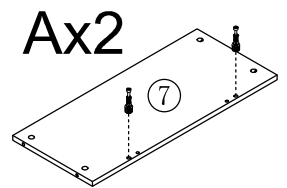
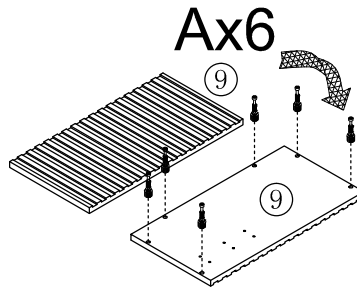
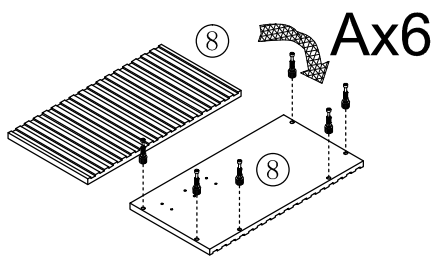
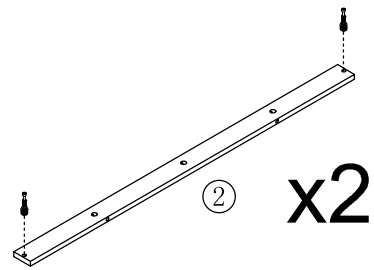
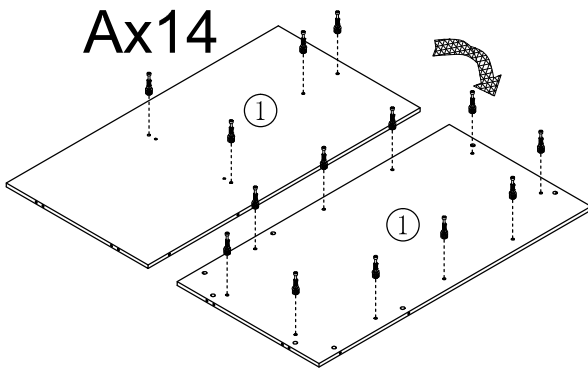

Step 2

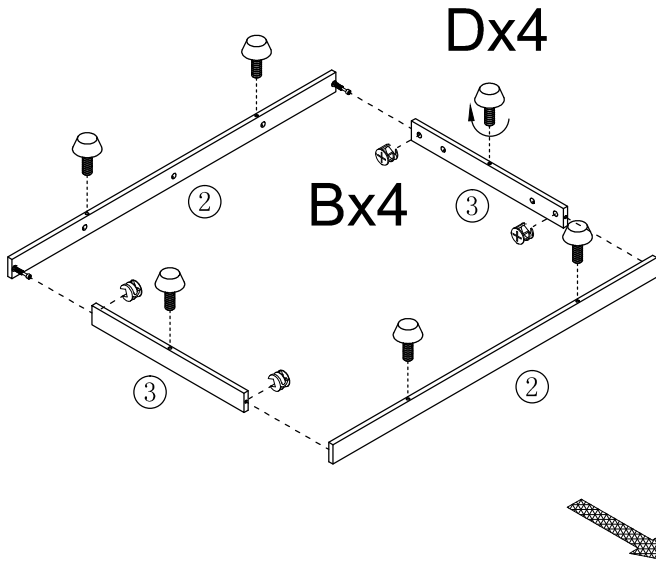

B	14PCS
Ø15*10mm	
D	6PCS
M6	

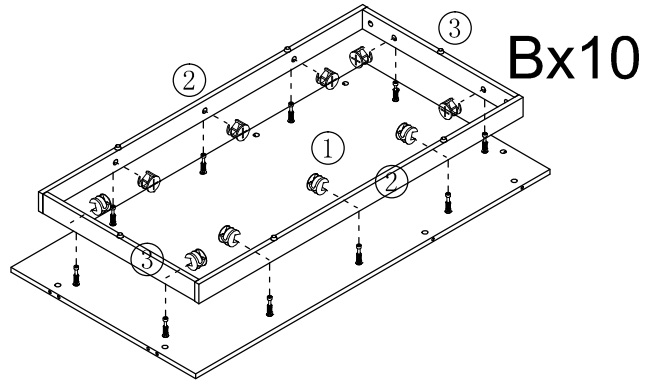
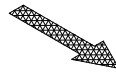

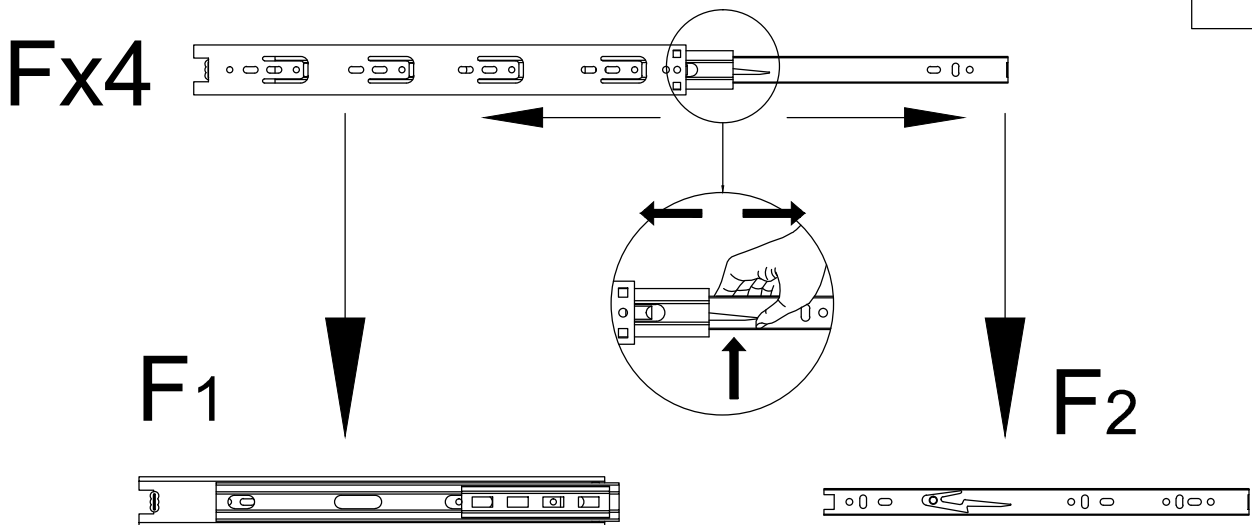

Step 3



F	4PCS
12"	

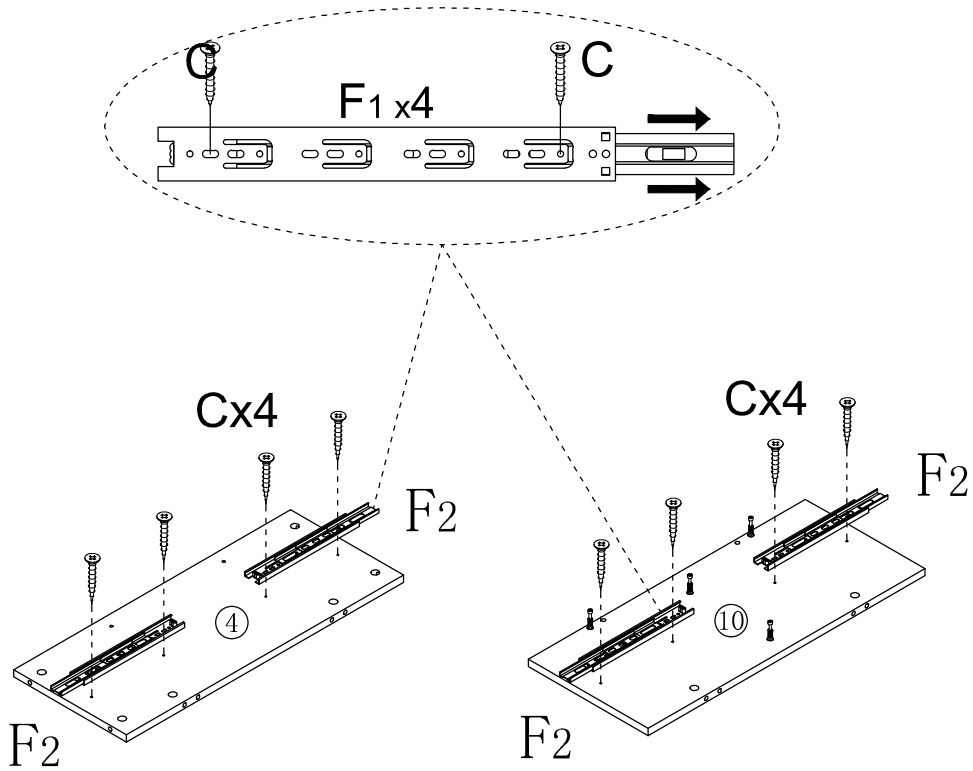

Step 4

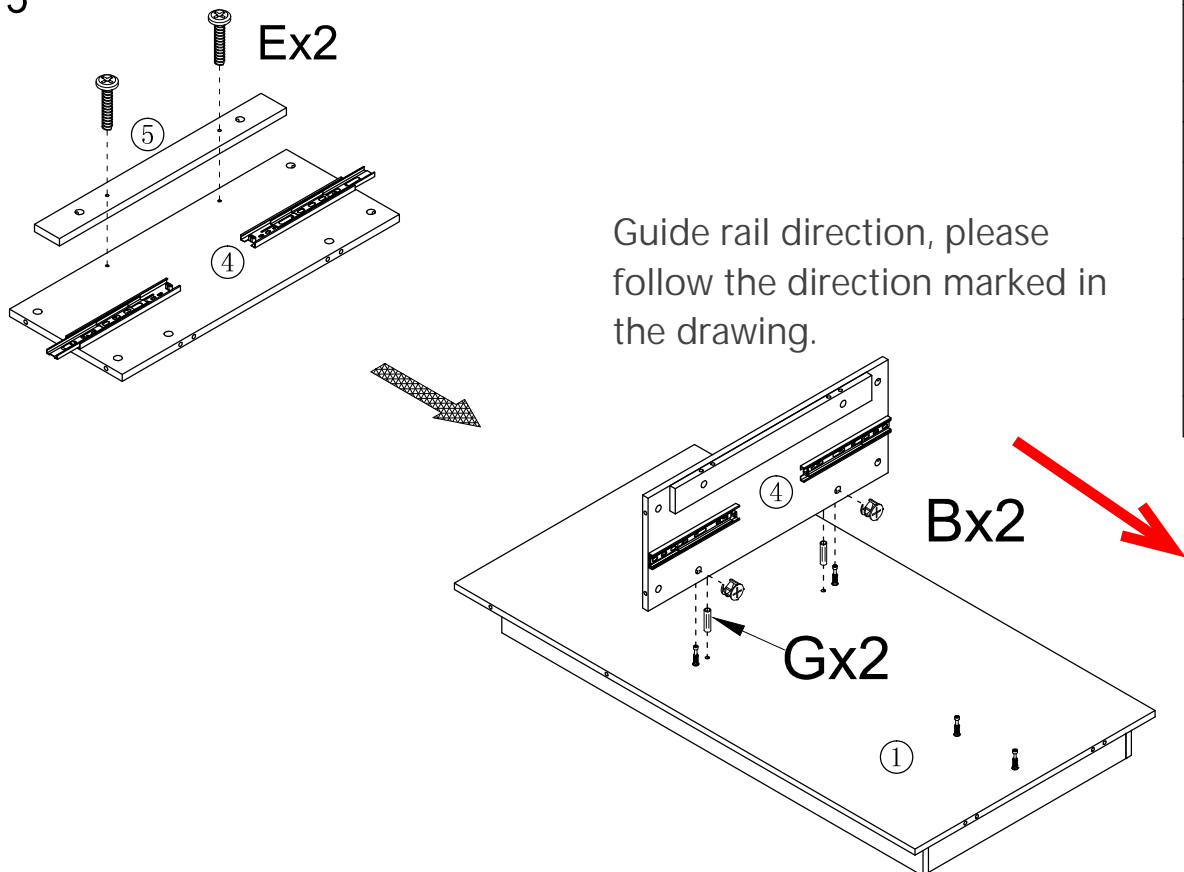

C	8PCS
	
Ø3.5*14mm	
F1	4PCS
	
12"	

Step 5



B	2PCS
	
Ø15*10mm	
G	2PCS
	
Ø8*30mm	
E	2PCS
	
M6*25mm	

Step 6

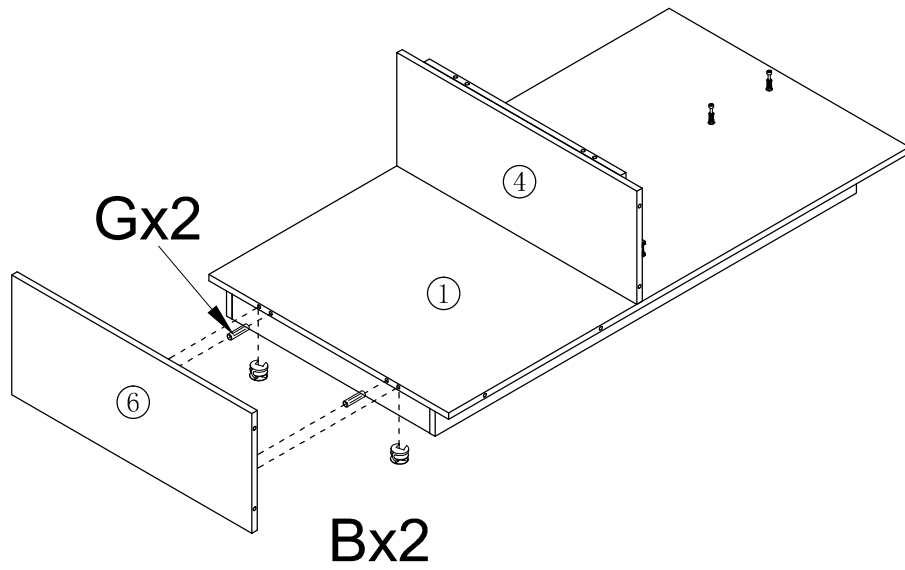

B | 2PCS



Ø15*10mm

G | 2PCS



Ø8*30mm

Step 7

Note the position of the screw holes.

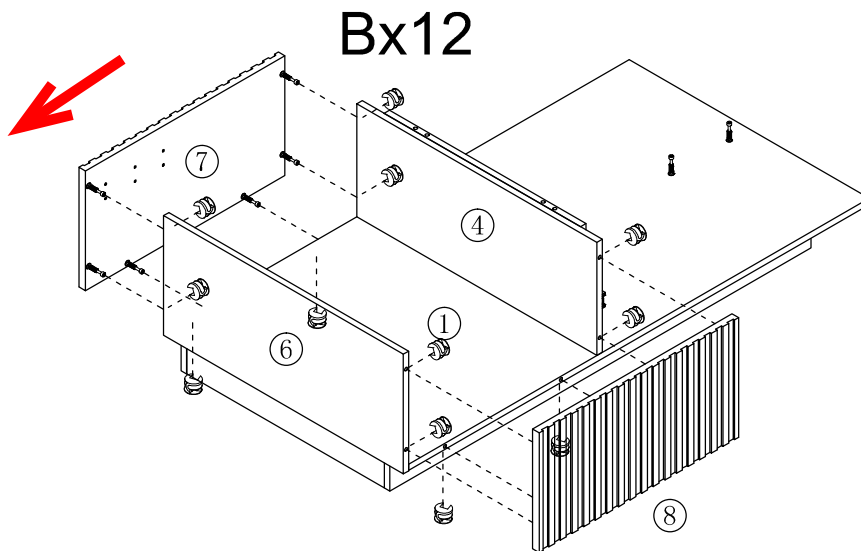

B | 12PCS





Ø15*10mm

Step 8

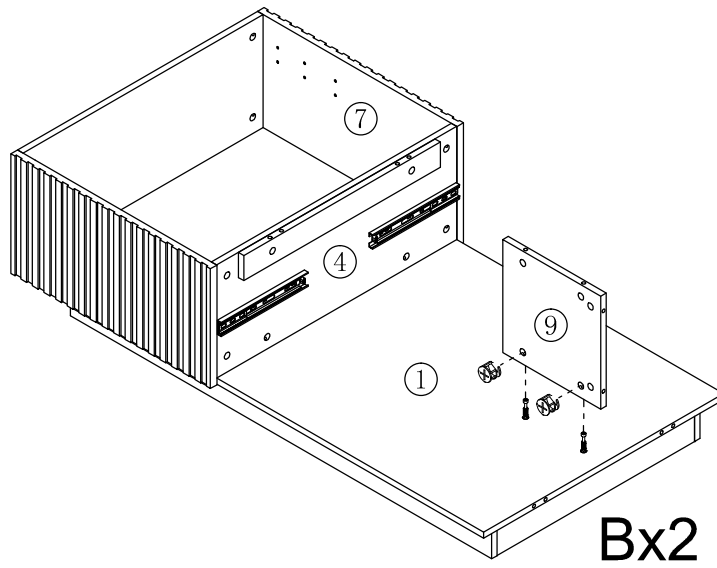
B	2PCS
	
Ø15*10mm	



Step 9

B	4PCS
	
Ø15*10mm	
G	2PCS
	
Ø8*30mm	

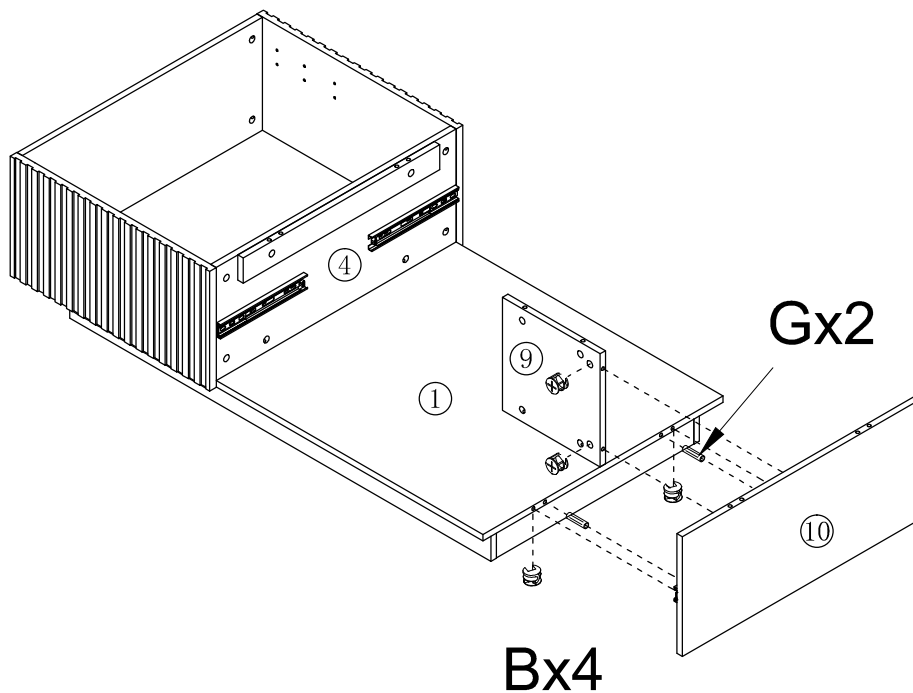

x2

Step 10

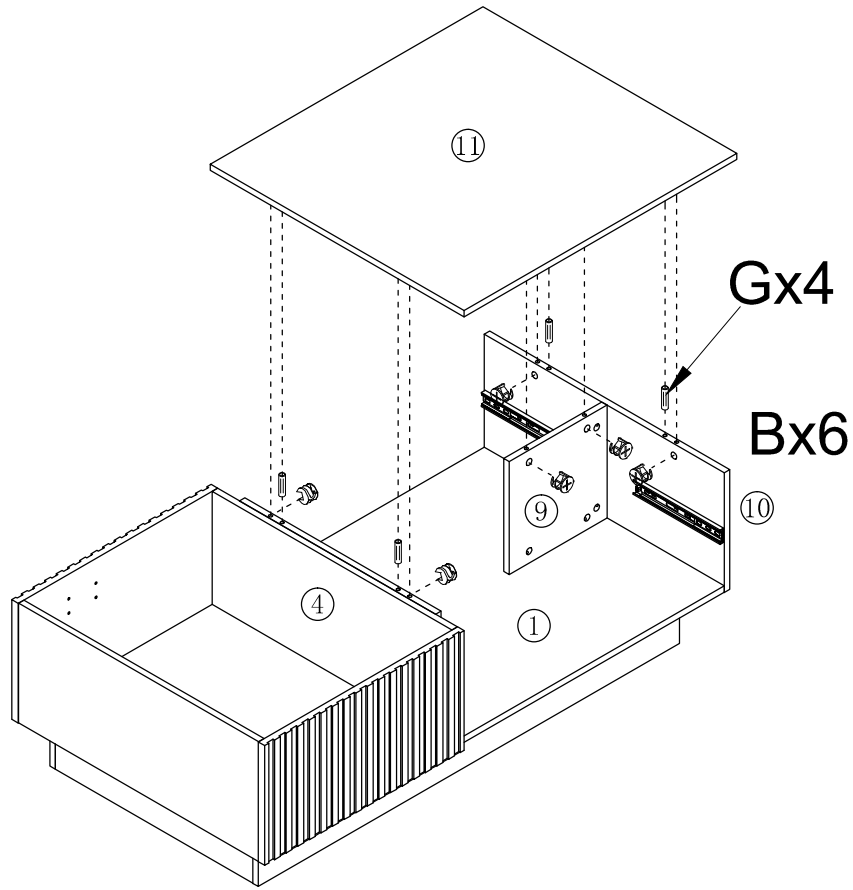

B	6PCS
Ø15*10mm	
G	4PCS
Ø8*30mm	

Step 11

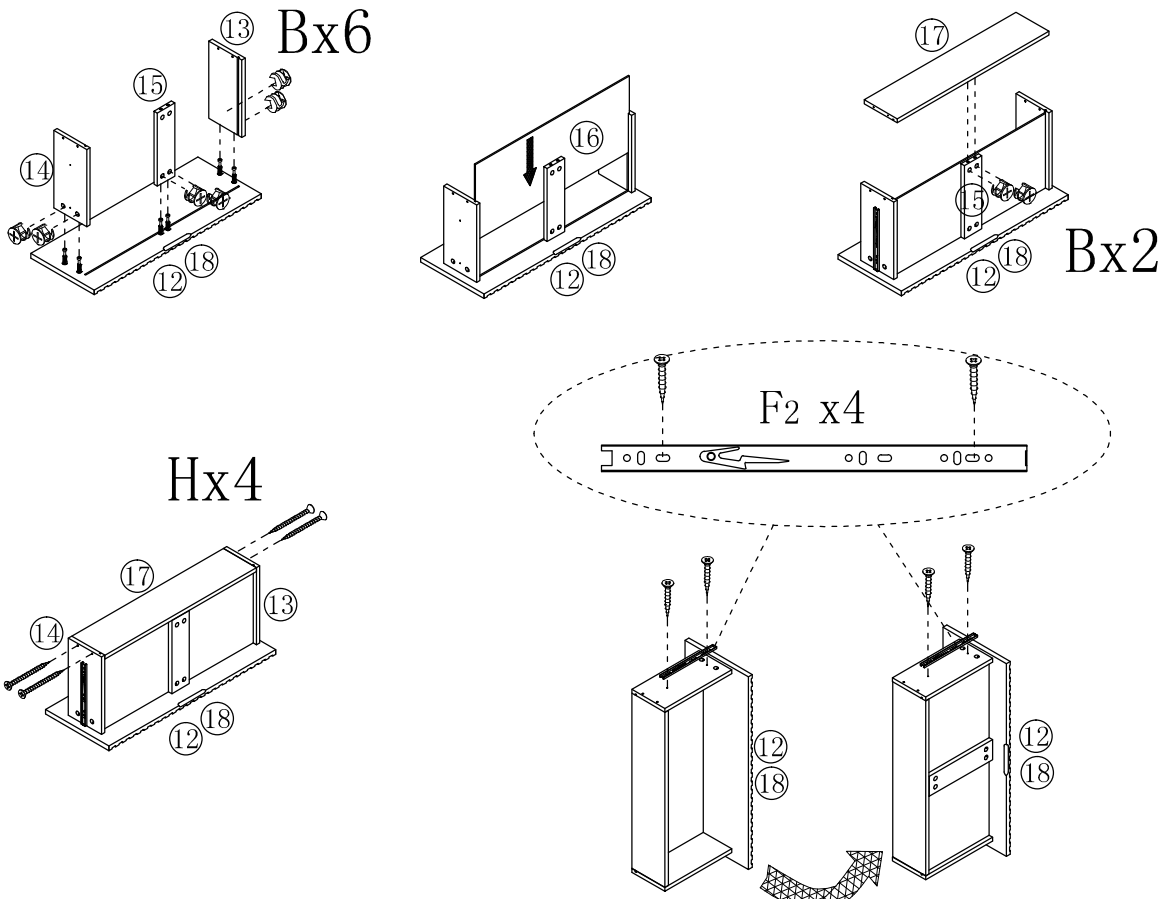

B	16PCS
Ø15*10mm	
C	8PCS
Ø3.5*14	
F2	4PCS
12"	
H	8PCS
Ø3.5*40	

x2

Step 12

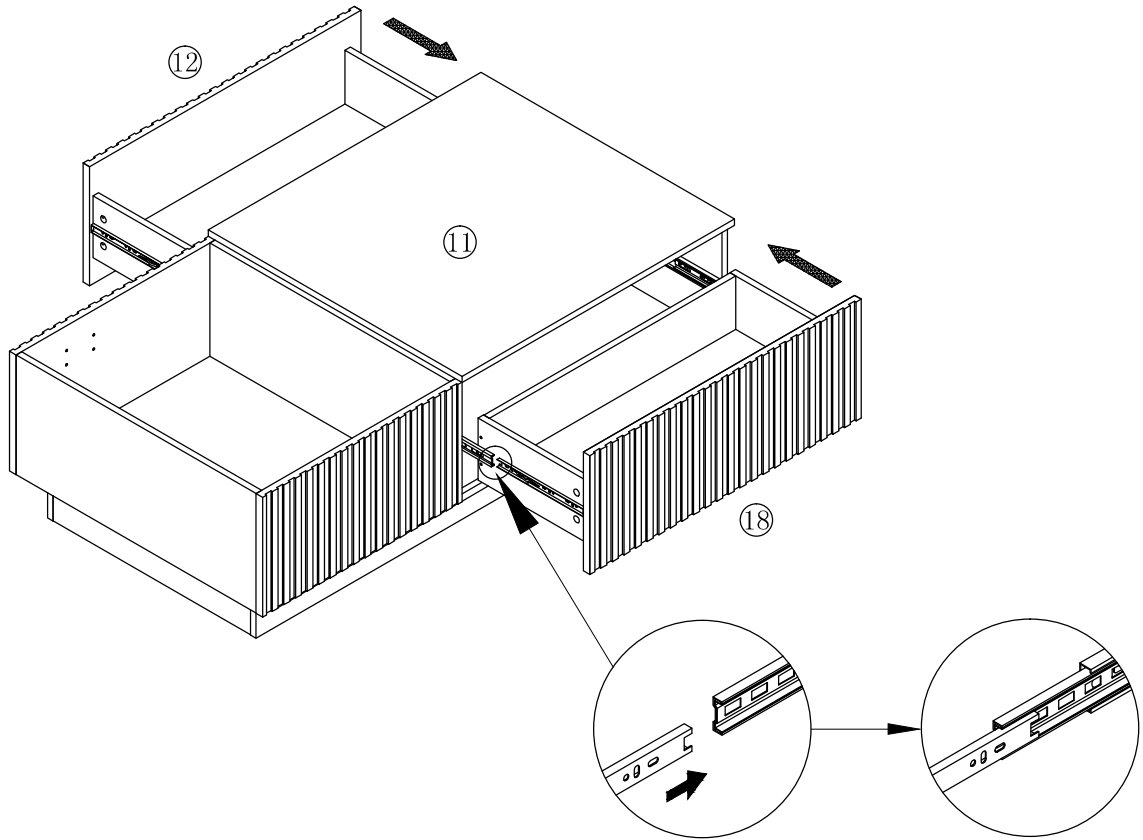

Step 13

J | 12PCS

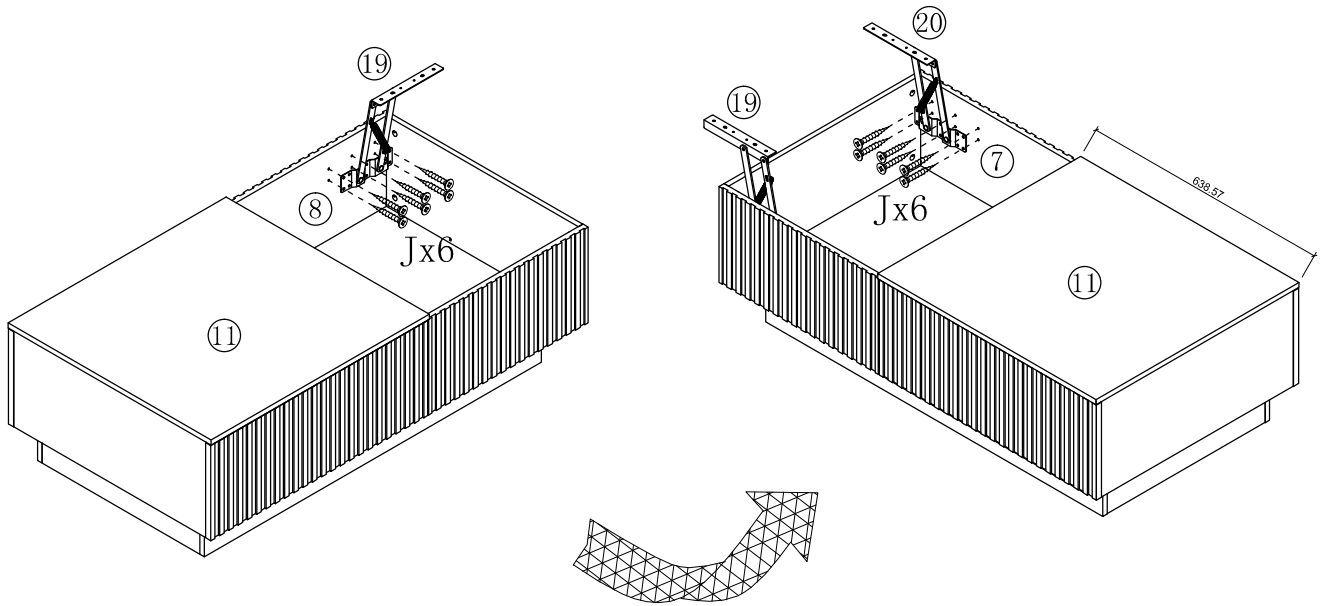
Ø5*14 mm



Step 14

Install Panel 21 by first attaching Screw I, then closing the panel. Check and adjust the gaps on the tabletop. Once the gaps are properly aligned, properly aligned, finally tighten Screw I and Screw C securely.

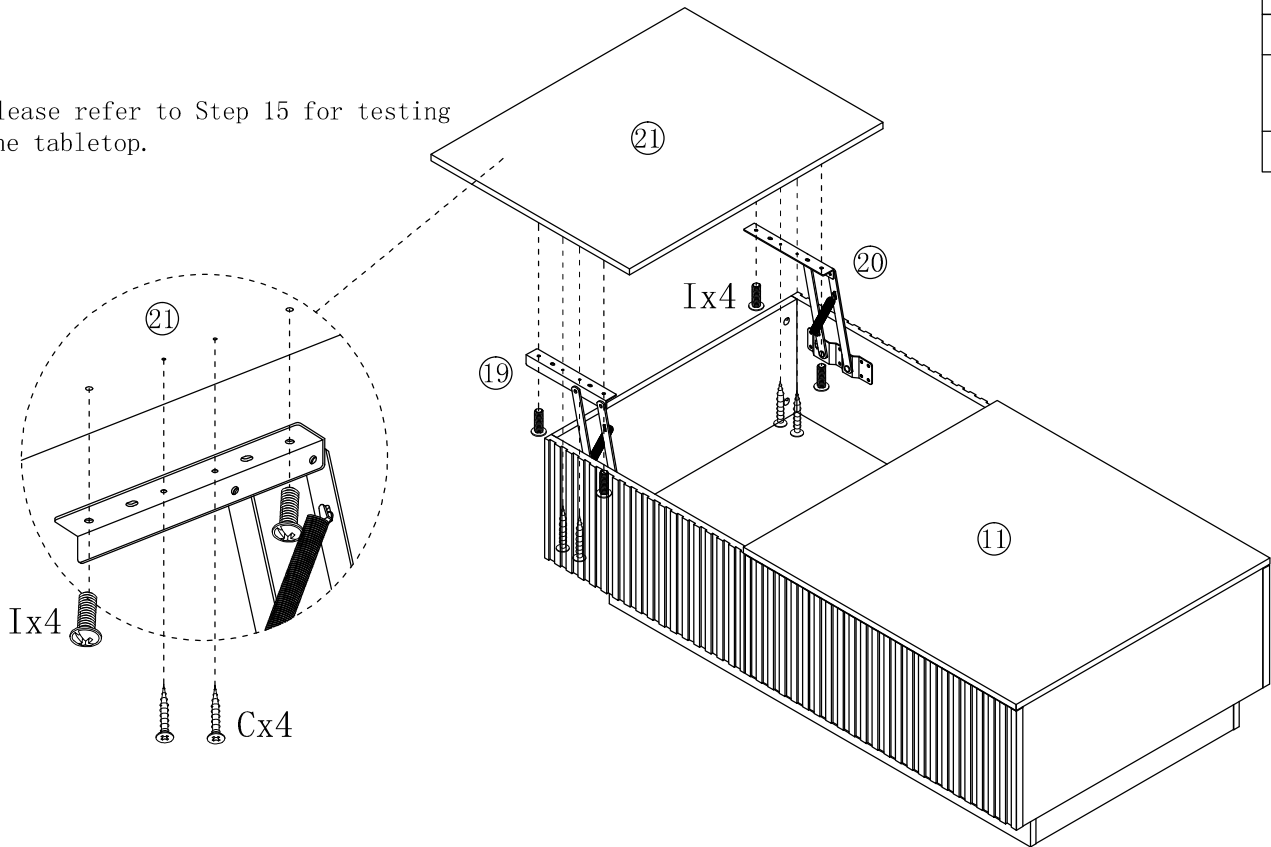
Please refer to Step 15 for testing the tabletop.



Step 15

To close the tabletop, gently push it forward in the direction of the arrow. Do not apply excessive downward force, as this may damage the components.

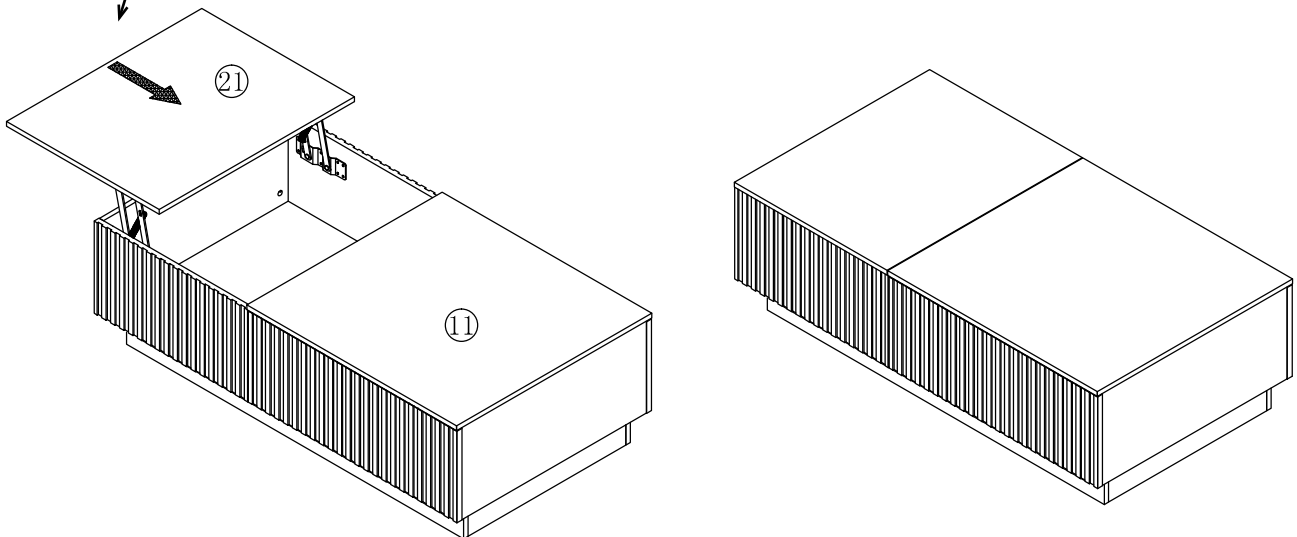

OK