

KEYWEST NIGHT STAND

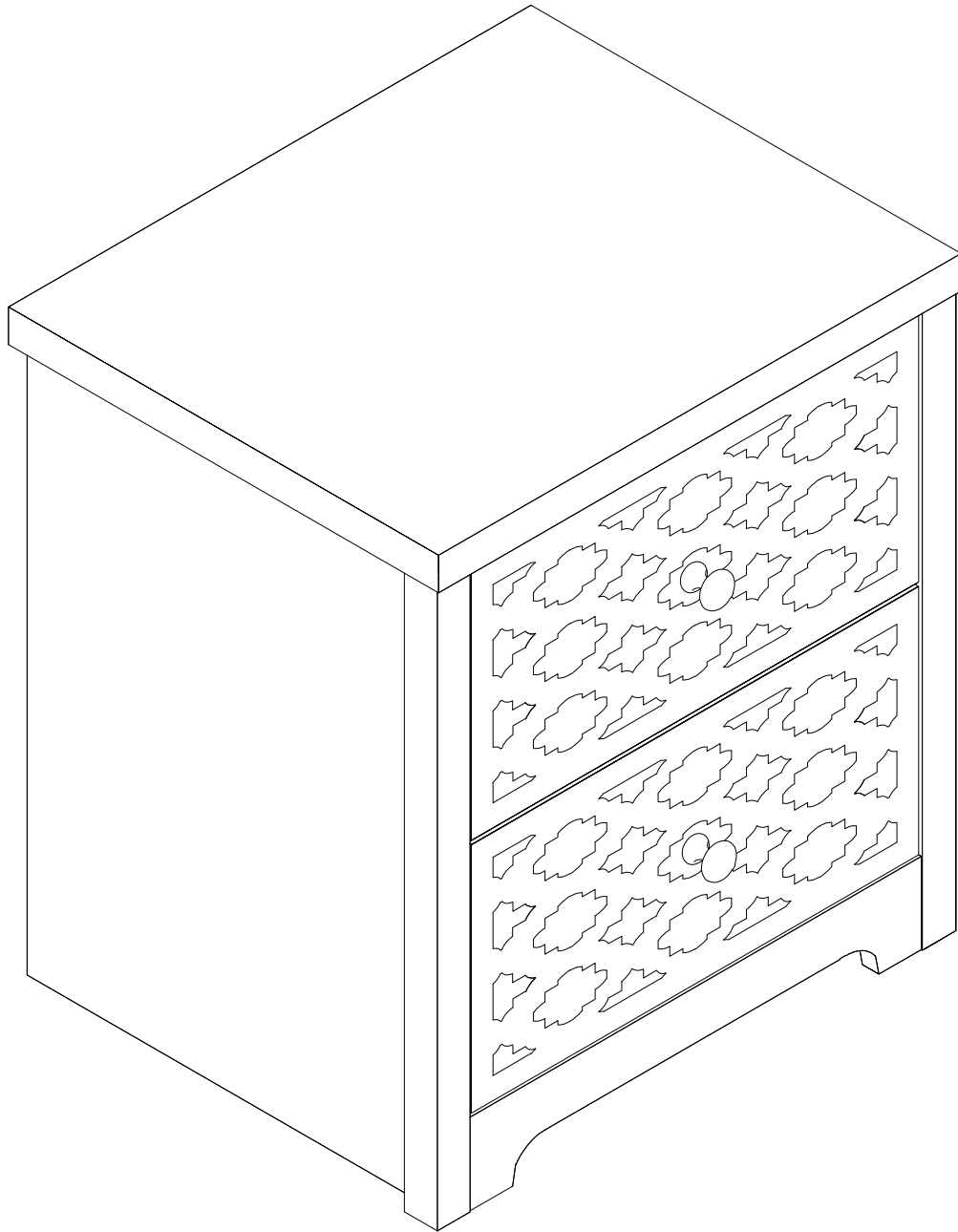

TOOL REQUIRED
OUTIL REQUIS
HERRAMIENTA REQUERIDA

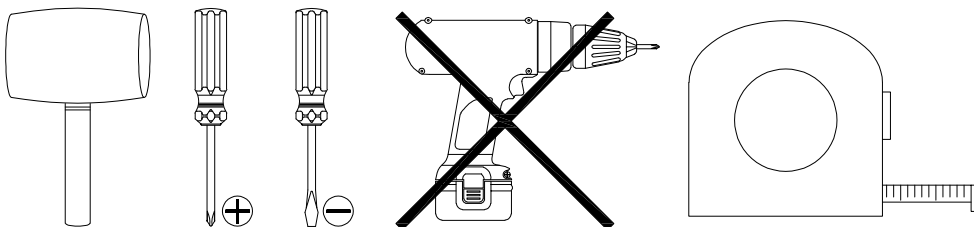

PERSON REQUIRED
PERSONNE REQUISE
PERSONA REQUERIDA

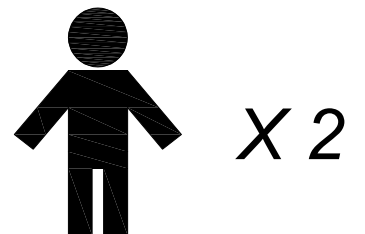

IMPORTANT - PLEASE READ CAREFULLY / IMPORTANT - VEUILLEZ LIRE ATTENTIVEMENT / IMPORTANTE: LEA ATENTAMENTE

- Avoid putting knives, forks, and other sharp objects straight onto your furniture as they could scratch and harm the finish.
- To clean your furniture, use an absorbent cloth that is soft, dry, and free of lint. Avoid using detergents since they could include substances that react and harm the finish.
- Clean up spills quickly. Water left over a prolonged period of time may cause damage. Alcohol, perfume, nail polishes, aftershave and some medication may cause severe finish damage if not cleaned immediately.
- Keep instruction for future use.
- Do not place furniture directly under windows.
- Due to the presence of small parts during assembly, keep out of reach of children until assembly is complete.

- Évitez de mettre des couteaux, des fourchettes et d'autres objets pointus directement sur vos meubles, car ils pourraient rayer et endommager la finition.
- Pour nettoyer vos meubles, utilisez un chiffon absorbant doux, sec et exempt de peluches. Évitez d'utiliser des détergents car ils pourraient contenir des substances qui réagissent et nuisent à la finition.
- Nettoyez rapidement les déversements. L'eau laissée sur une période prolongée peut causer des dommages. L'alcool, le parfum, les vernis à ongles, l'après-rasage et certains médicaments peuvent causer de graves dommages à la finition s'ils ne sont pas nettoyés immédiatement.
- Conservez les instructions pour une utilisation ultérieure.
- Ne placez pas de meubles directement sous les fenêtres.
- En raison de la présence de petites pièces lors du montage, tenir hors de portée des enfants jusqu'à la fin du montage.

- Evite poner cuchillos, tenedores y otros objetos afilados directamente sobre sus muebles, ya que podrían rayar y dañar el acabado.
- Para limpiar sus muebles, use un paño absorbente que sea suave, seco y sin pelusa. Evite el uso de detergentes, ya que podrían incluir sustancias que reaccionen y dañen el acabado.
- Limpie los derrames rápidamente. El agua que queda durante un período prolongado de tiempo puede causar daños. El alcohol, el perfume, los esmaltes de uñas, la loción para después del afeitado y algunos medicamentos pueden causar daños graves en el acabado si no se limpian inmediatamente.
- Conserve las instrucciones para una utilización posterior.
- No coloque los muebles directamente debajo de las ventanas.
- Debido a la presencia de piezas pequeñas durante el montaje, manténgalas fuera del alcance de los niños hasta que se complete el montaje.

WARNING / AVERTISSEMENT / ADVERTENCIA

- Please use your furniture correctly and safely. Improper use can cause safety hazard, or damage to your furniture or household items.
- Serious or fatal crushing injuries can occur from furniture tip-over.
- To help prevent tip-over :
 - Place heaviest items in the lowest drawers or shelf.
 - Never allow children to climb or hang on drawer, shelf or doors.
 - Always monitor your child's activity when in the nursery.
 - Do not allow standing in drawer or shelf.
 - Do not allow standing on top of this product.
 - To avoid head injury, do not allow children to play underneath open drawer.
 - Accessory items must be securely fastened to this product according to the instructions provided with those items.
 - Do not leave drawers open when not in use.

- Veuillez utiliser vos meubles correctement et en toute sécurité. Une mauvaise utilisation peut entraîner des risques pour la sécurité ou endommager vos meubles ou vos articles ménagers.
- Des blessures graves ou mortelles par écrasement peuvent survenir en cas de renversement de meubles.
- Pour aider à prévenir le renversement :
 - Placez les articles les plus lourds dans les tiroirs ou l'étagère les plus bas.
 - Ne laissez jamais les enfants grimper ou s'accrocher aux tiroirs, aux étagères ou aux portes.
 - Surveillez toujours l'activité de votre enfant lorsqu'il est à la crèche.
 - Ne laissez pas se tenir dans un tiroir ou une étagère.
 - Ne laissez pas vous tenir sur ce produit.
 - Pour éviter les blessures à la tête, ne laissez pas les enfants jouer sous le tiroir ouvert.
 - Les accessoires doivent être solidement fixés à ce produit conformément aux instructions fournies avec ces articles.
 - Ne laissez pas les tiroirs ouverts lorsqu'ils ne sont pas utilisés.

- Por favor, utilice sus muebles de forma correcta y segura. El uso inadecuado puede causar peligro para la seguridad o daños a sus muebles o artículos del hogar.
- Pueden producirse lesiones graves o mortales por aplastamiento por el vuelco de los muebles.
- Para ayudar a prevenir el vuelco:
 - Coloque los artículos más pesados en los cajones o estantes más bajos.
 - Nunca permita que los niños trepen o se cuelguen de los cajones, estantes o puertas.
 - Vigile siempre la actividad de su hijo cuando esté en la guardería.
 - No permita que se queden de pie en el cajón o la estantería.
 - No permita que se pongan de pie encima de este producto.
 - Para evitar lesiones en la cabeza, no permita que los niños jueguen debajo del cajón abierto.
 - Los accesorios deben fijarse firmemente a este producto de acuerdo con las instrucciones suministradas con los mismos.
 - No deje los cajones abiertos cuando no se utilicen.

MINIFIX CAM & MINIFIX BOLT / BOULON MINIFIX & CAMÉRA MINIFIX / CÂMARA MINIFIX & PERNO MINIFIX

MINIFIX BOLT
BOULON MINIFIX
PERNO MINIFIX

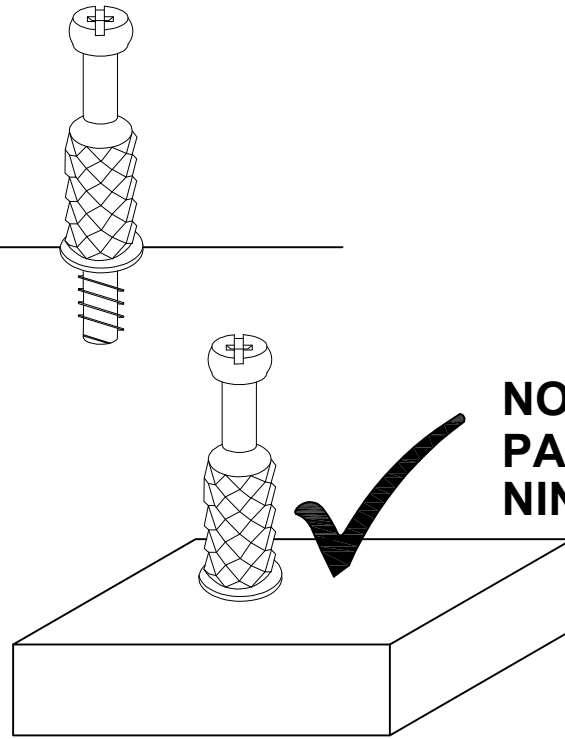
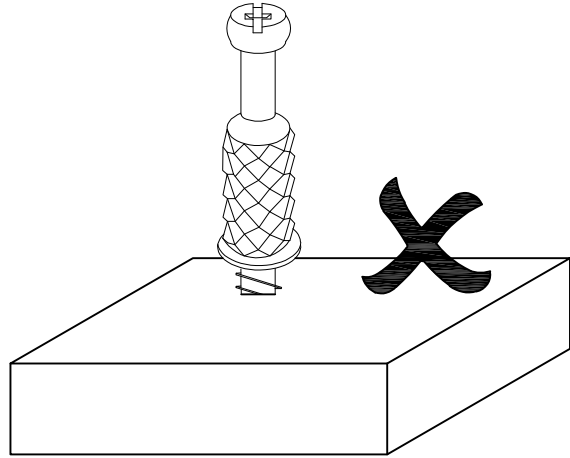

NO GAP
PAS D'ÉCART
NINGUN ESPACIO

MINIFIX CAM
CAMÉRA MINIFIX
CÂMARA MINIFIX

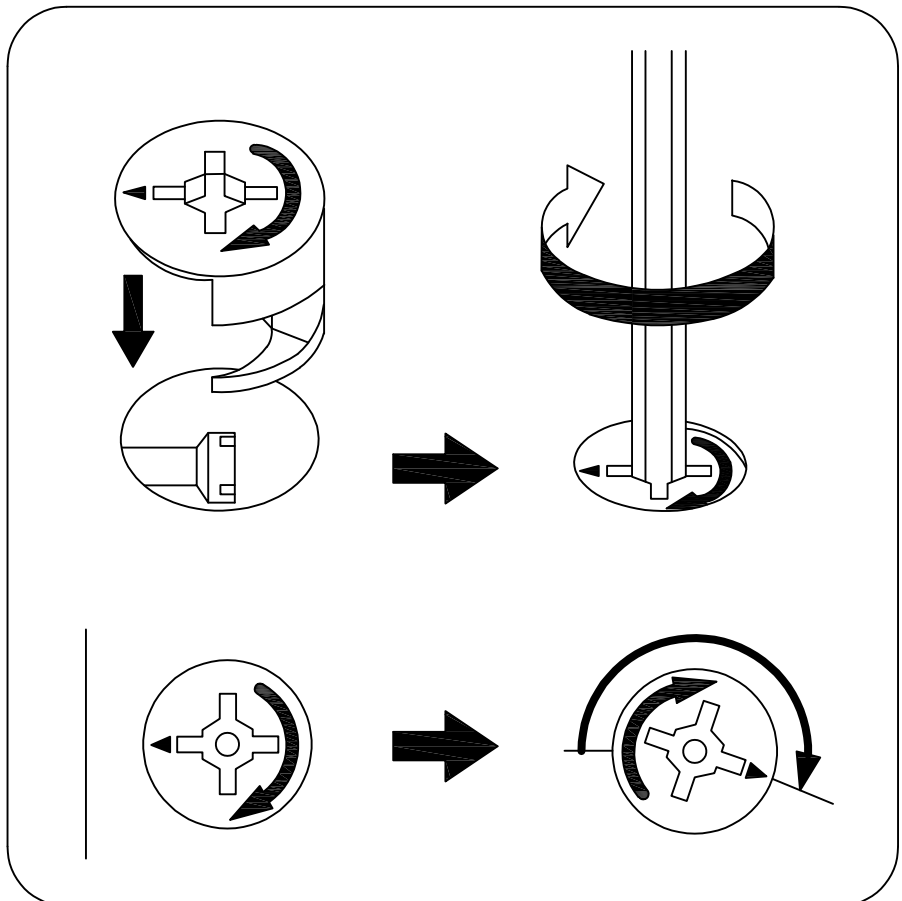
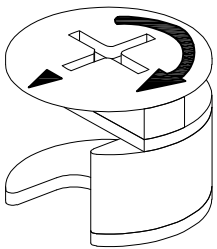

WOOD DOWEL / CHEVILLE EN BOIS / TACO DE MADERA

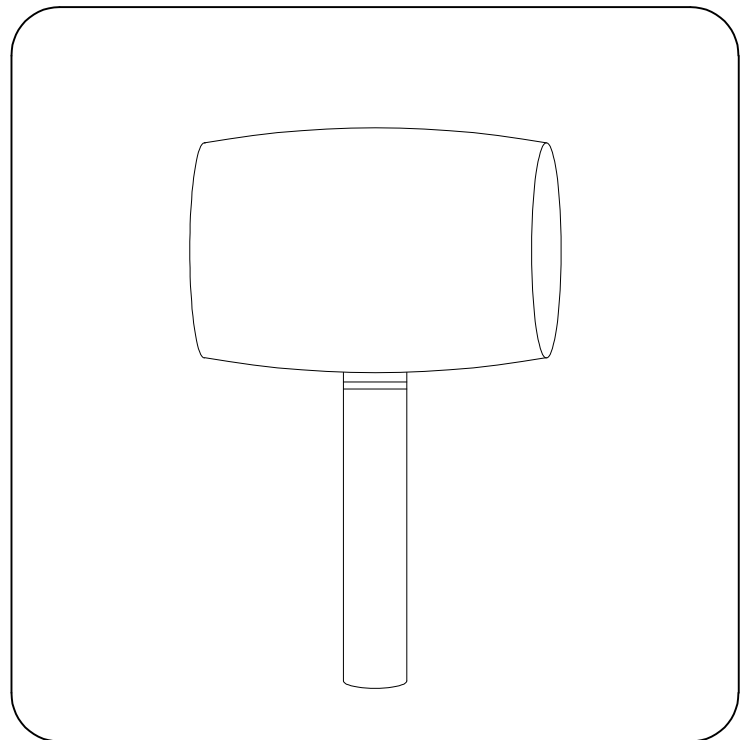
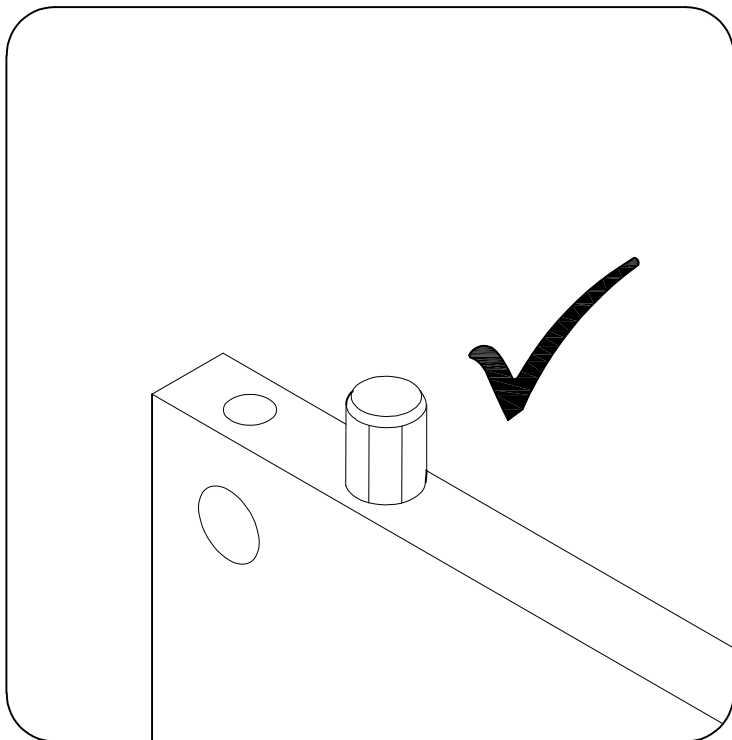
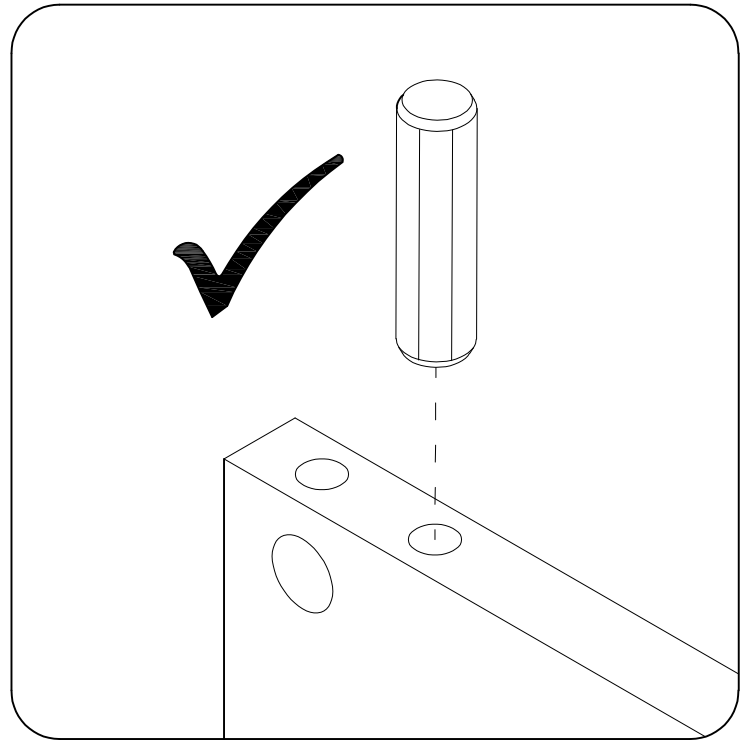
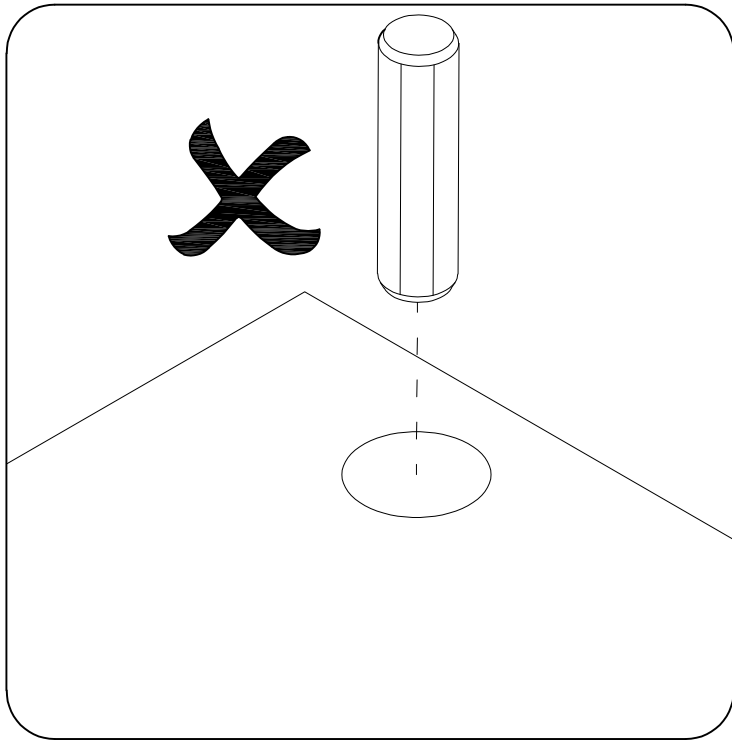

PARTLIST / LISTE DES PIÈCES / LISTA DE PIEZAS

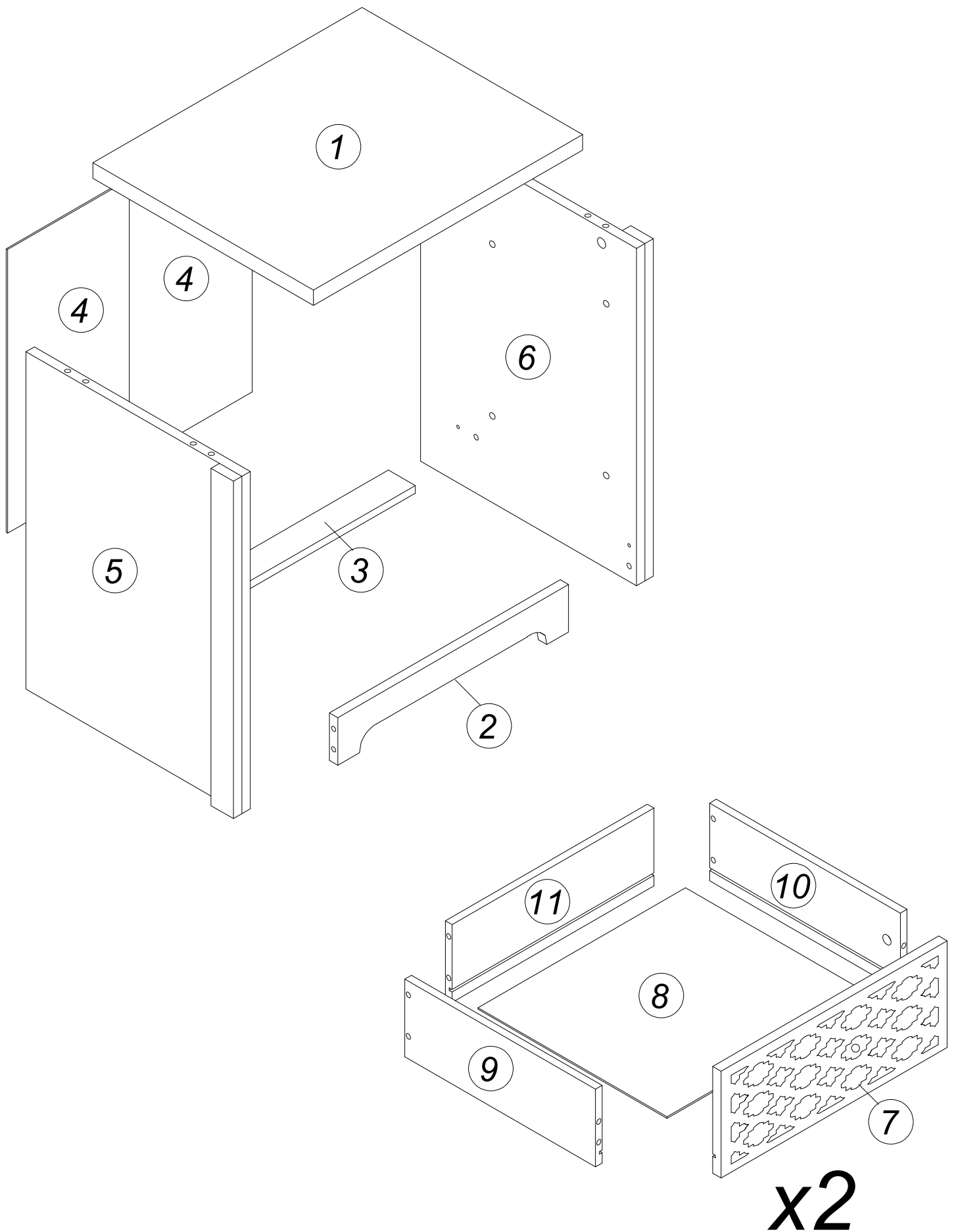

HARDWARE / QUINCAILLERIE / HERRAJE

(A) MINIFIX 16MM



8 UNITS

(B) MINICAM 16MM



8 UNITS

(C) CSK M4 X 32 MM



8 UNITS

(D) ALLEN KEY



1 UNITS

(E) DOWEL 8 X 30MM

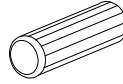

8 UNITS

(F) NAIL

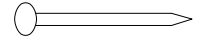

10 UNITS

(G) CSK M3 X 12 MM

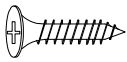

12 UNITS

(H) EURO SCREW 5 X 8



8 UNITS

(I) MINIFIX 5807(12MM)



4 UNITS

(J) MINICAM 5574 (12MM)



4 UNITS

(K) CP 2X15X30

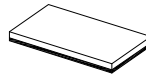

4 UNITS

(L) DOWEL 6 X 30MM

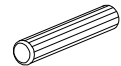

8 UNITS

(M) DRAWER SLIDE
SD 8879 - EV12 (300mm 1mm)



2 SETS

(N) KNOB SJ312 GD



2 UNITS

(O) SCREW HANDLE
M3.5 X 25mm

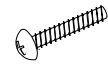

2 UNITS

ASSEMBLY INSTRUCTION / INSTRUCTIONS DE MONTAGE INSTRUCCIONES DE MONTAJE

STEP 1

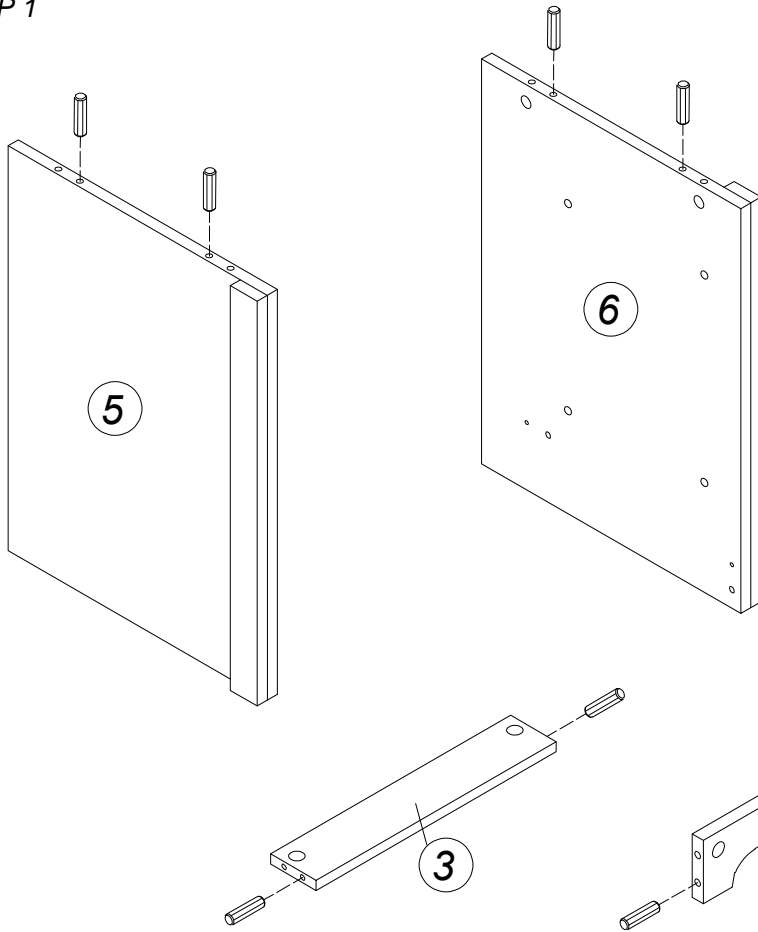

E		DOWEL 8 X 30 MM	8 Pcs
---	--	-----------------	-------

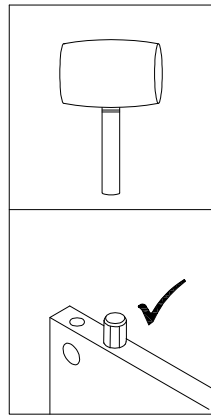
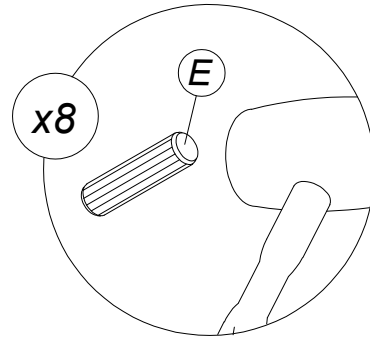

STEP 2

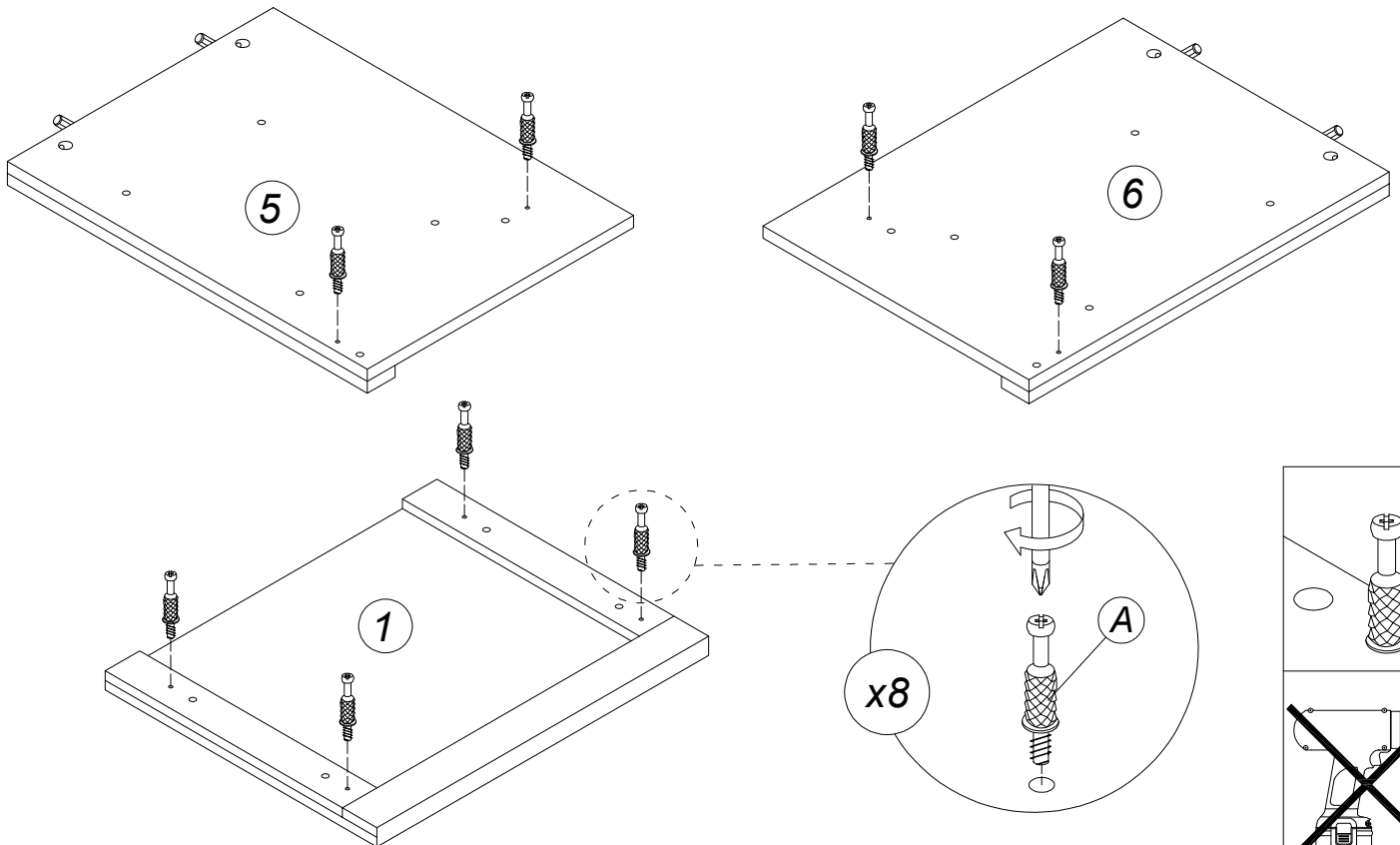

A		MINIFIX 16MM	8Pcs
---	--	--------------	------

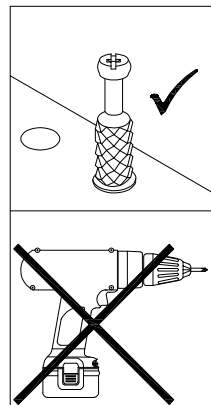
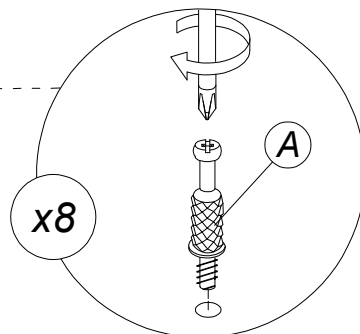

ASSEMBLY INSTRUCTION / INSTRUCTIONS DE MONTAGE INSTRUCCIONES DE MONTAJE

STEP 3

L		DOWEL 6 X 30 MM	8Pcs
---	--	-----------------	------

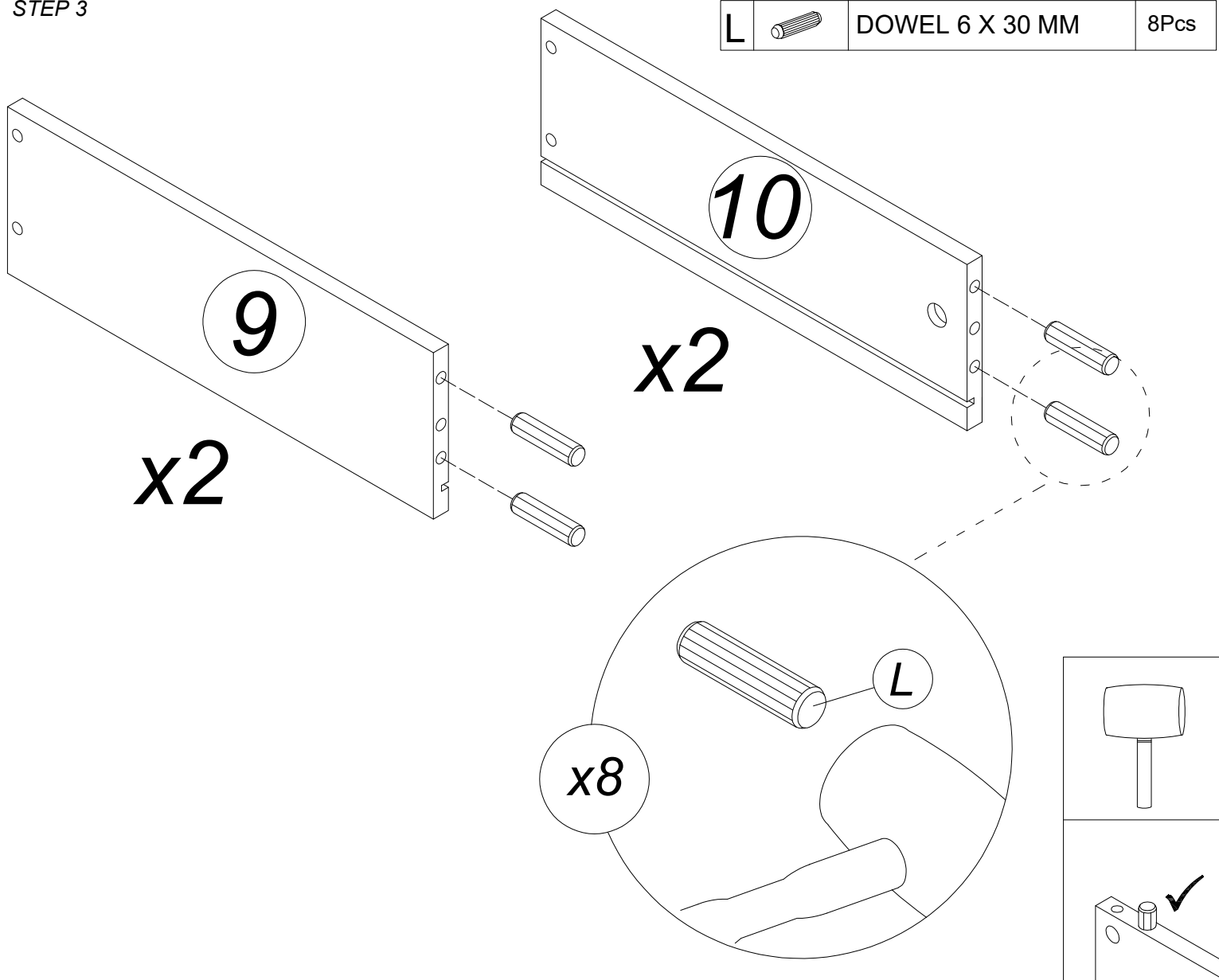

STEP 4

I		MINIFIX 5807 (12MM)	4Pcs
---	---	---------------------	------

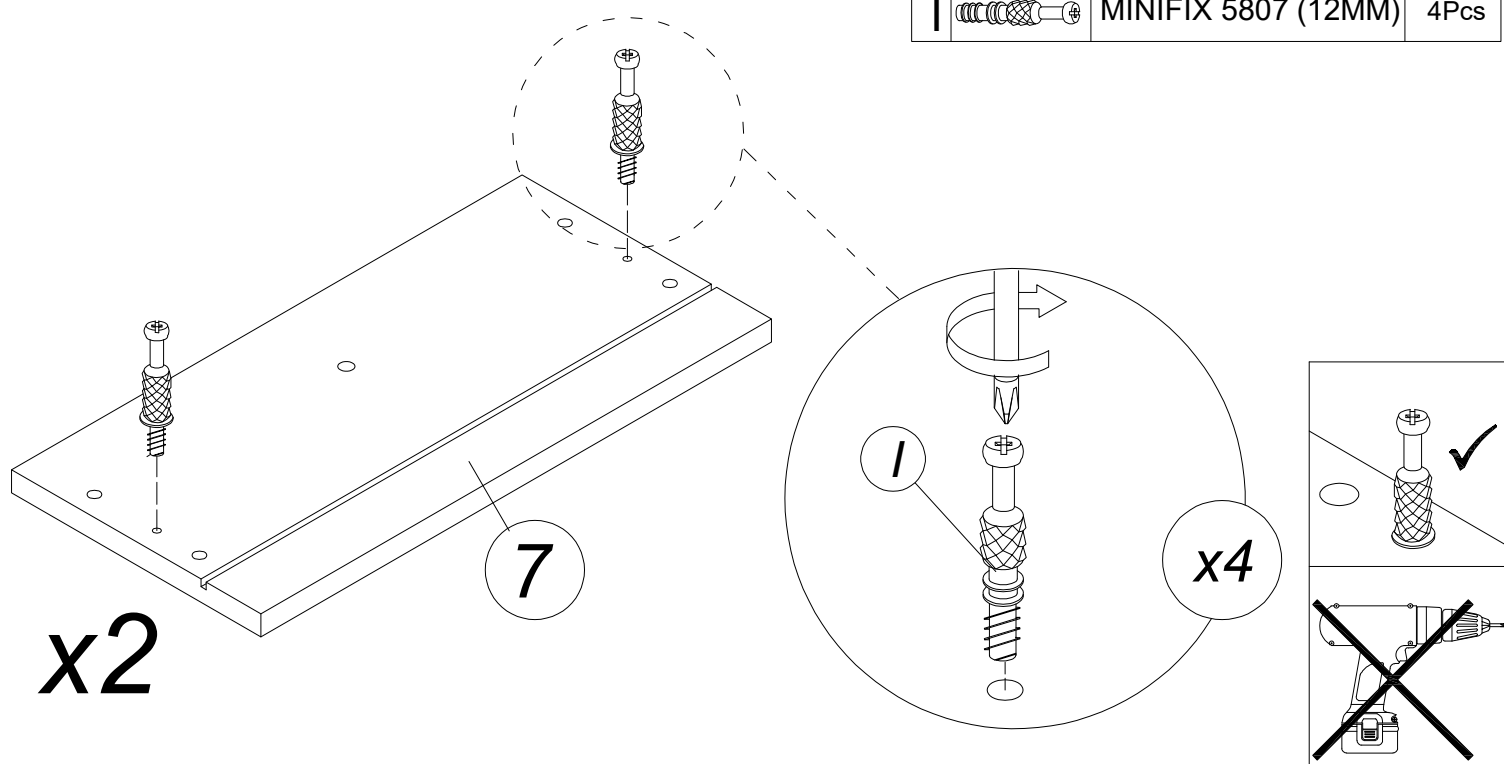

ASSEMBLY INSTRUCTION / INSTRUCTIONS DE MONTAGE INSTRUCCIONES DE MONTAJE

REMARK: FOLLOW POINT / REMARQUE : SUIVRE LE POINT / OBSERVACIÓN: SEGUIR PUNTO

LEFT SIDE

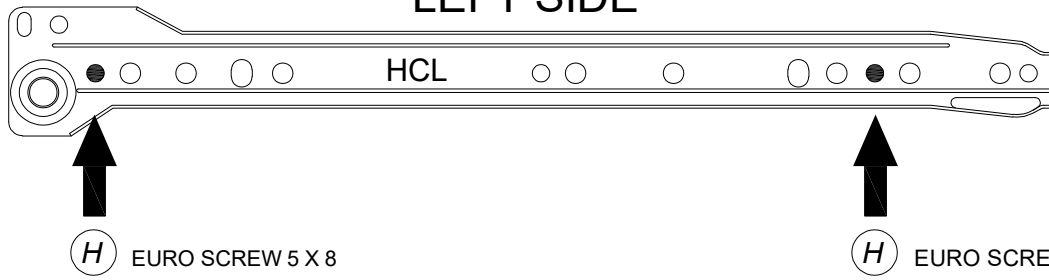

RIGHT SIDE

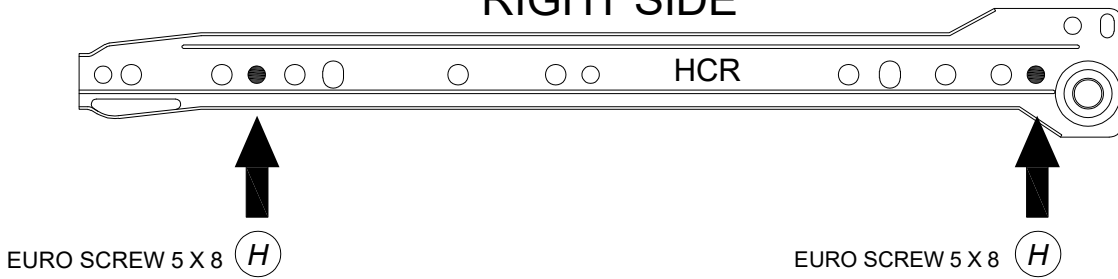

STEP 5

M		DRAWER SLIDE SD 8879 - EV12 (300mm_1mm)	2 Set
H		EURO SCREW	8 Pcs

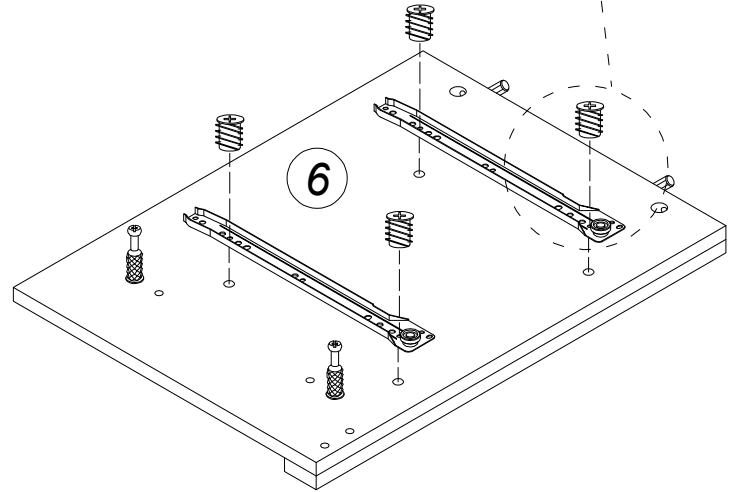
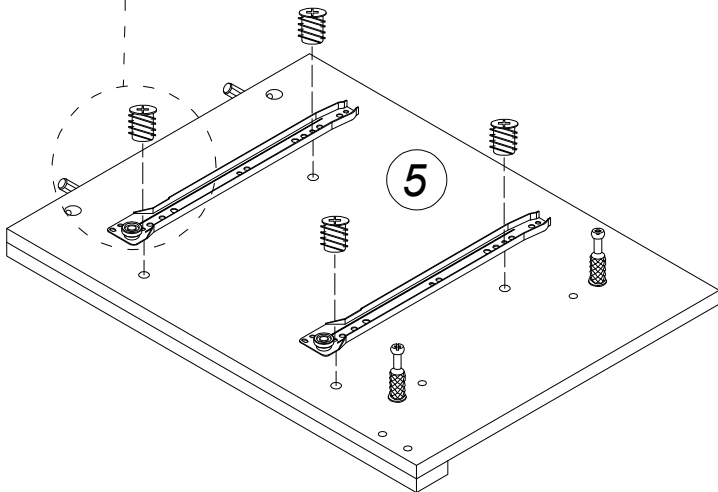
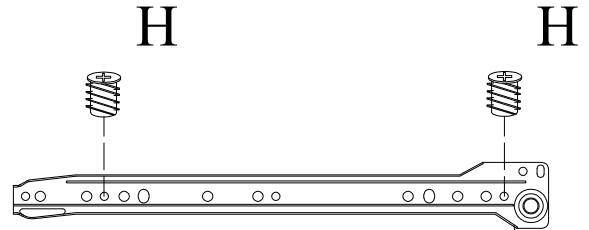
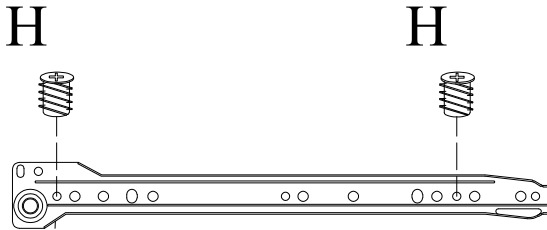

ASSEMBLY INSTRUCTION / INSTRUCTIONS DE MONTAGE INSTRUCCIONES DE MONTAJE

STEP 6

B		MINICAM 16MM	2Pcs
----------	--	--------------	------

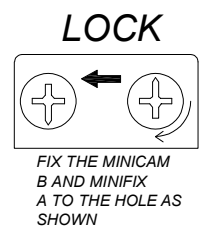
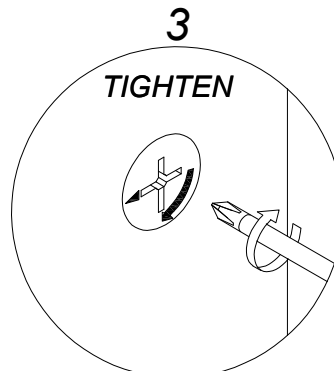
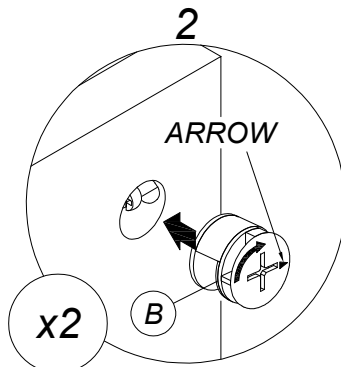
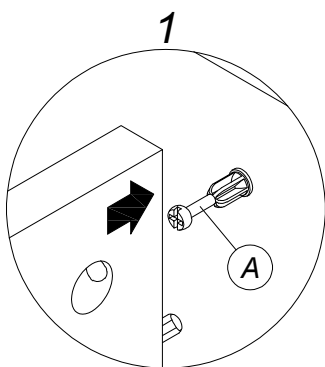
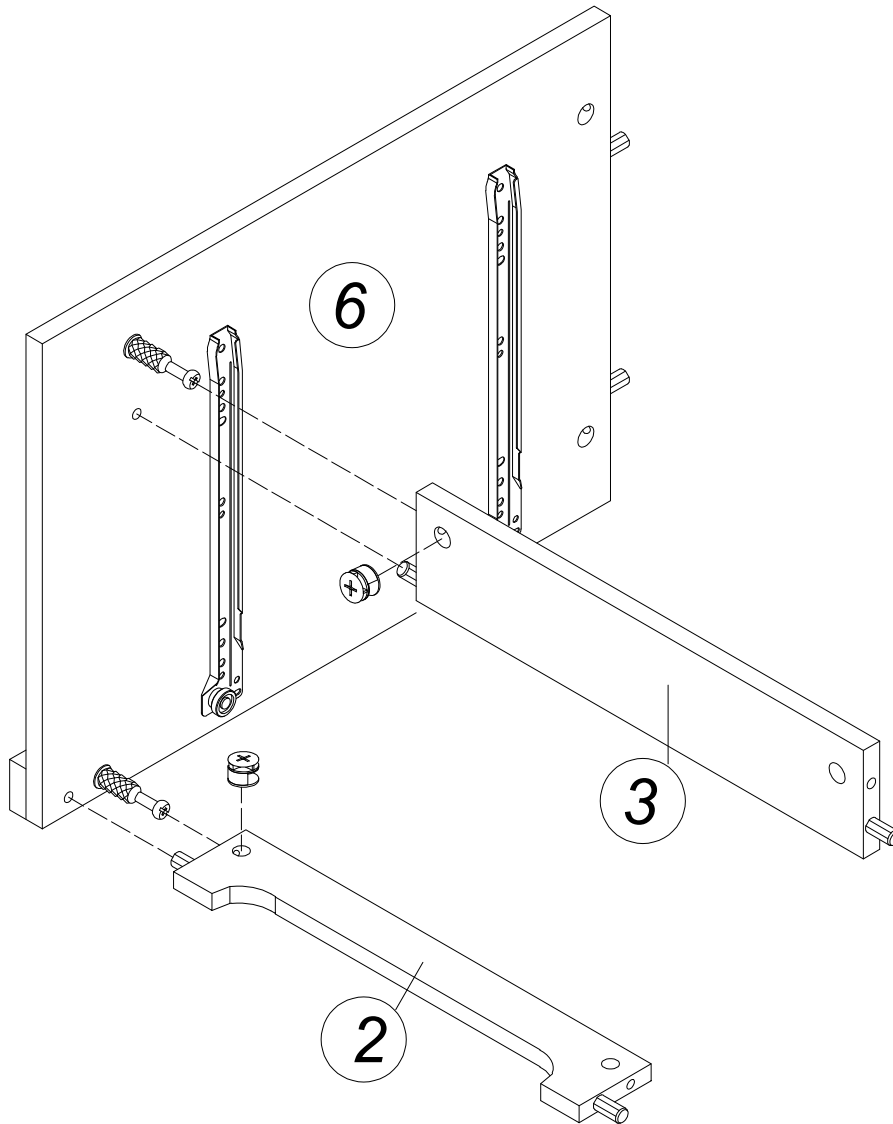

ASSEMBLY INSTRUCTION / INSTRUCTIONS DE MONTAGE INSTRUCCIONES DE MONTAJE

STEP 7

B		MINICAM 16MM	2Pcs
---	--	--------------	------

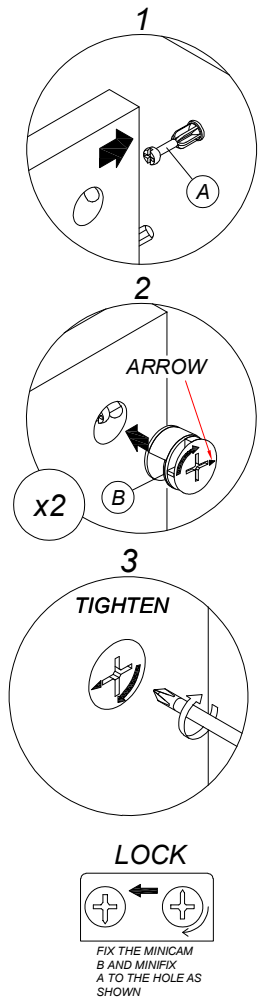
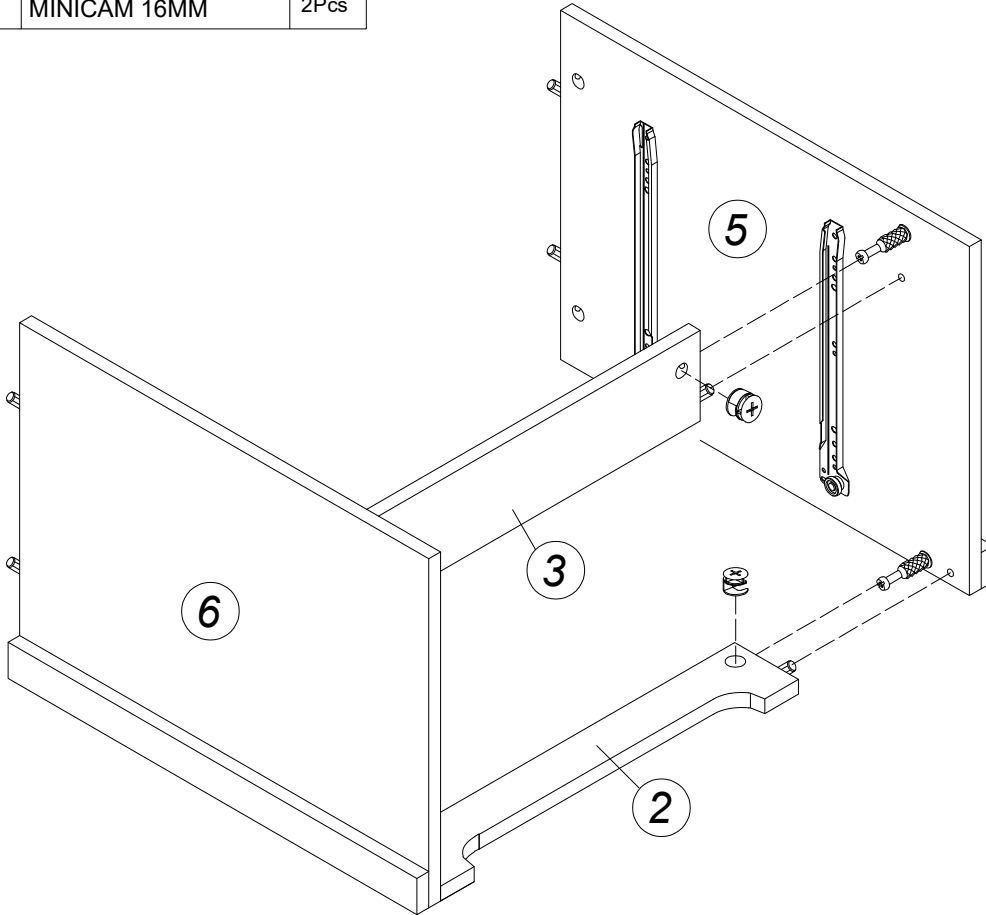

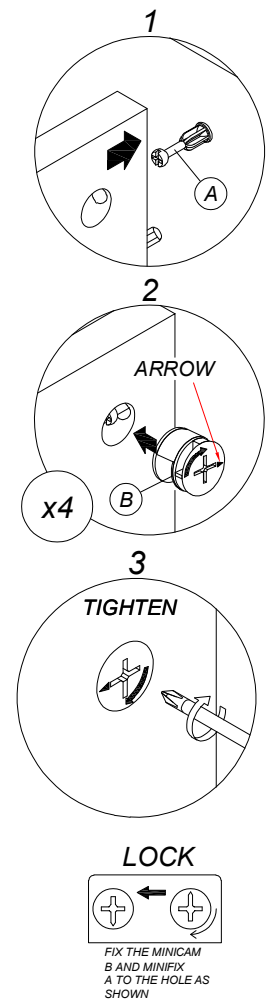
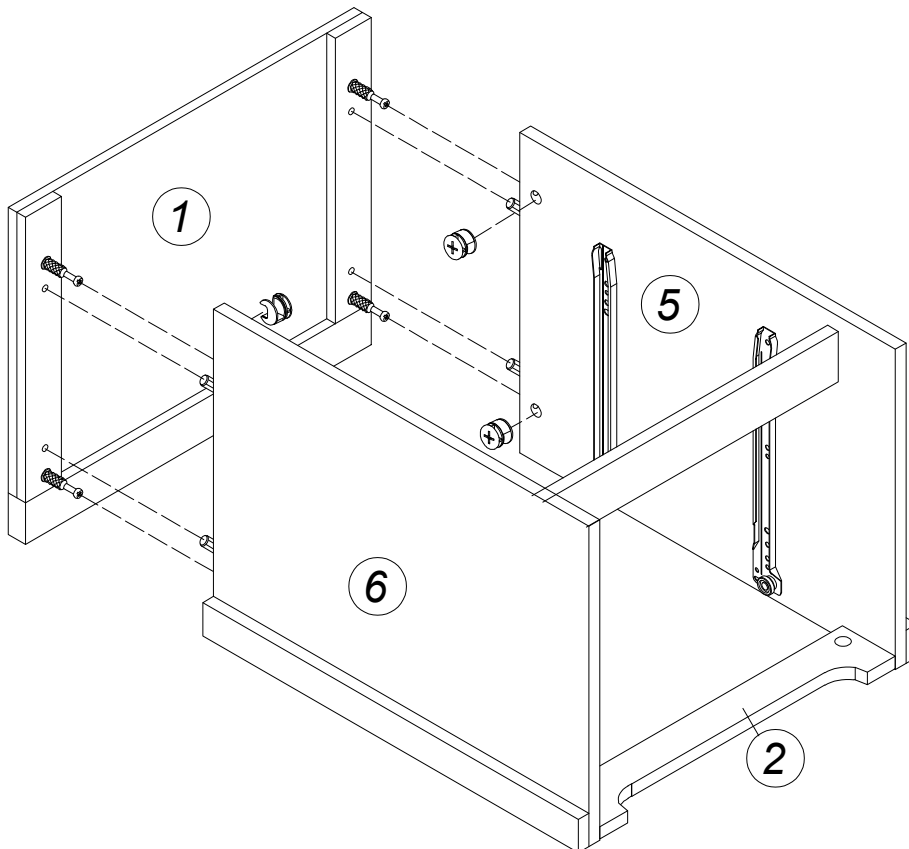

STEP 8

B		MINICAM 16MM	4 Pcs
---	--	--------------	-------



ASSEMBLY INSTRUCTION / INSTRUCTIONS DE MONTAGE INSTRUCCIONES DE MONTAJE

STEP 9

F		NAIL	10Pcs
K		CP 2X15X30	4Pcs

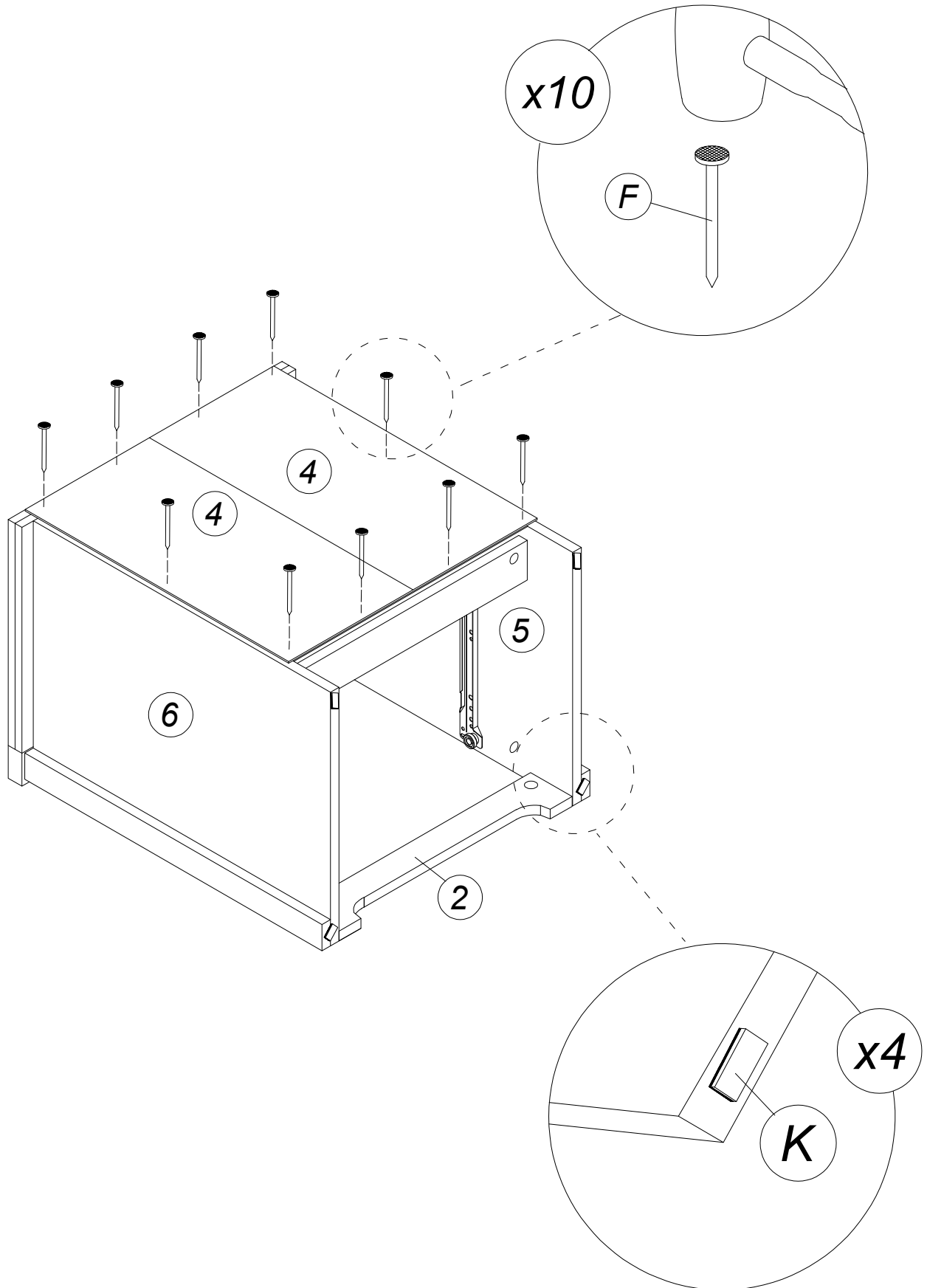

ASSEMBLY INSTRUCTION / INSTRUCTIONS DE MONTAGE INSTRUCCIONES DE MONTAJE

STEP 10

C		CSK M4 X 32MM	8Pcs
---	--	---------------	------

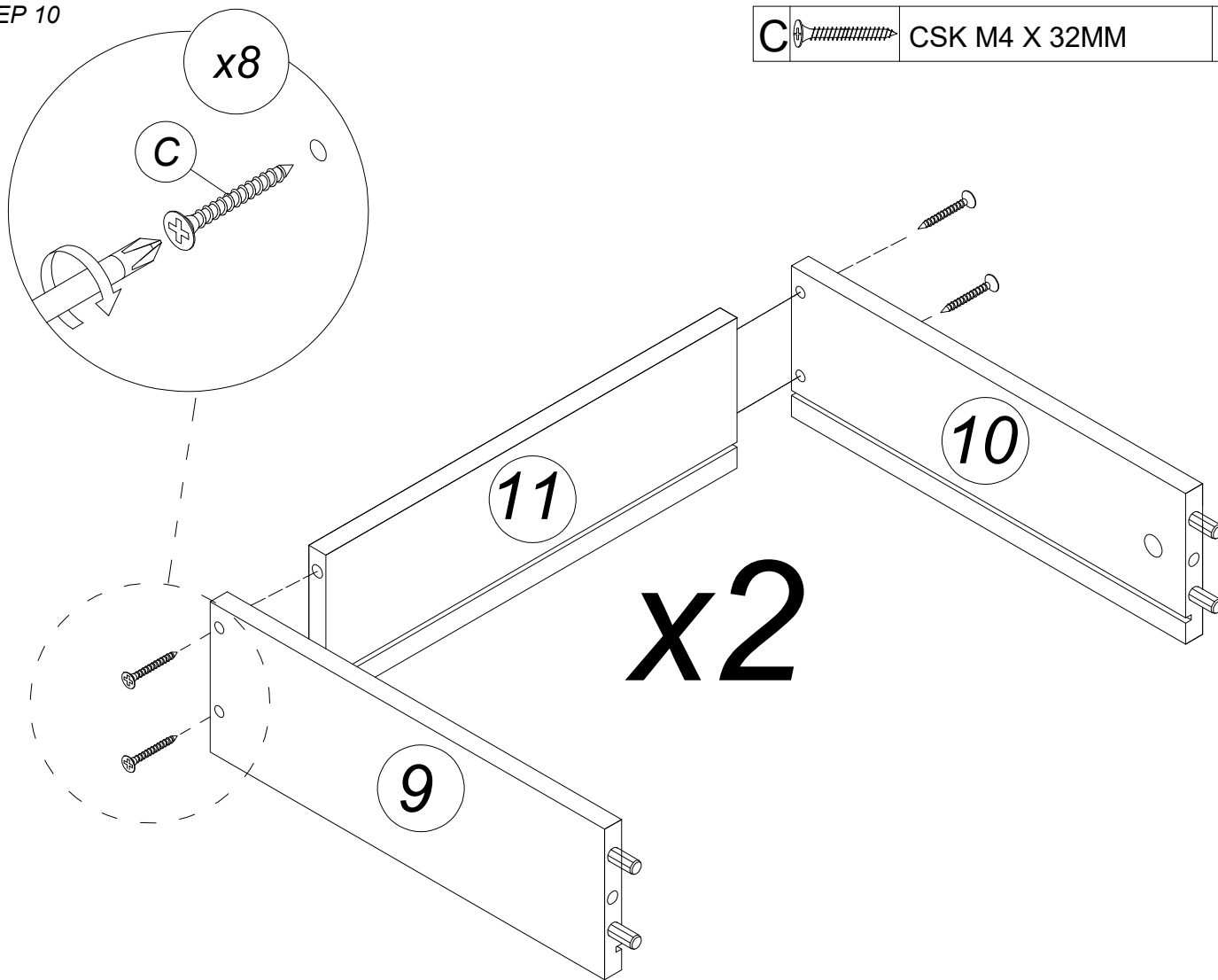

STEP 11

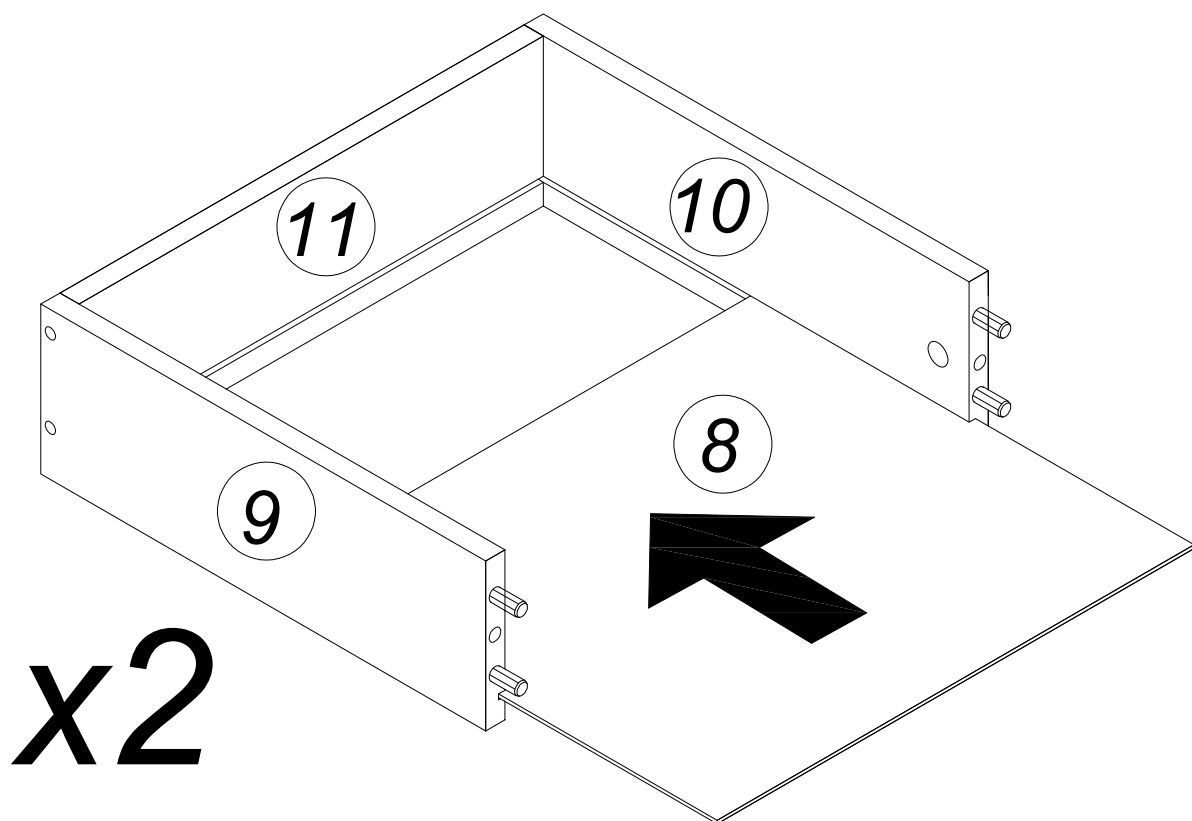

ASSEMBLY INSTRUCTION / INSTRUCTIONS DE MONTAGE INSTRUCCIONES DE MONTAJE

STEP 12

J



MINICAM 5574 (12MM)

4Pcs

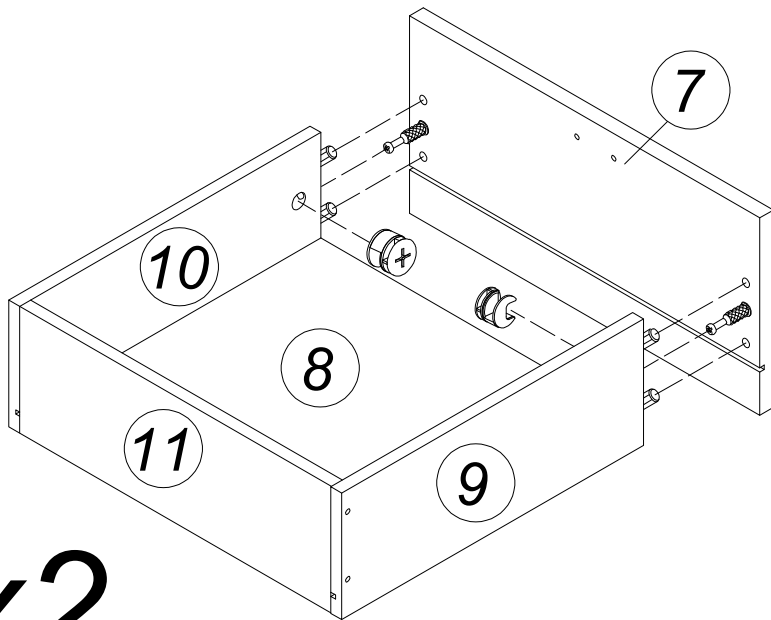

x2

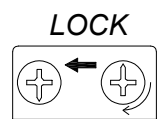
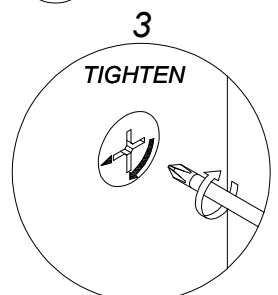
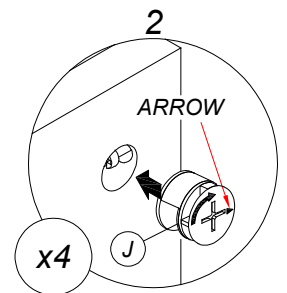
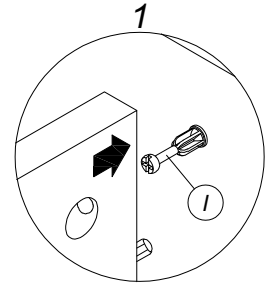

FIX THE MINICAM
J AND MINIFIX
I TO THE HOLE AS
SHOWN

ASSEMBLY INSTRUCTION / INSTRUCTIONS DE MONTAGE INSTRUCCIONES DE MONTAJE

LEFT SIDE

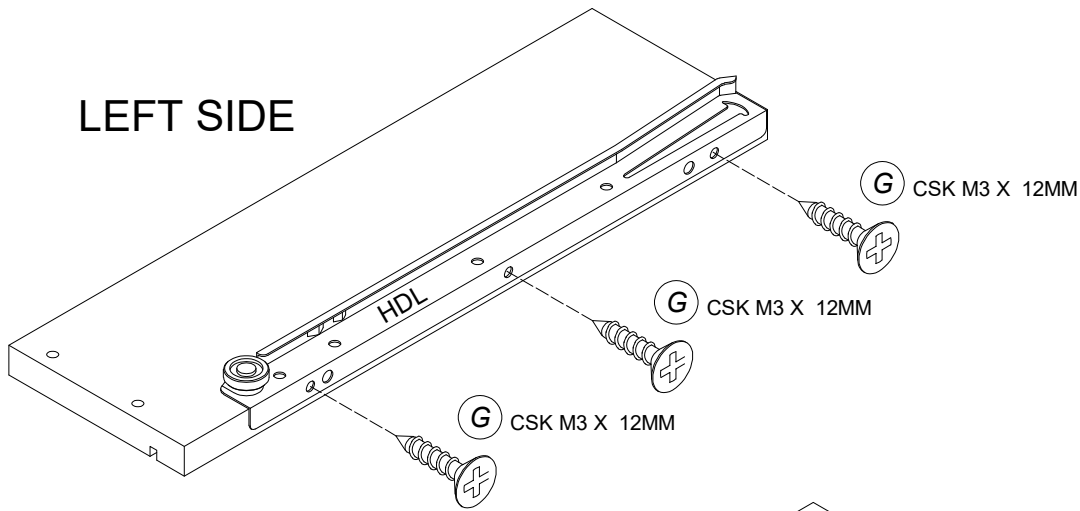

RIGHT SIDE

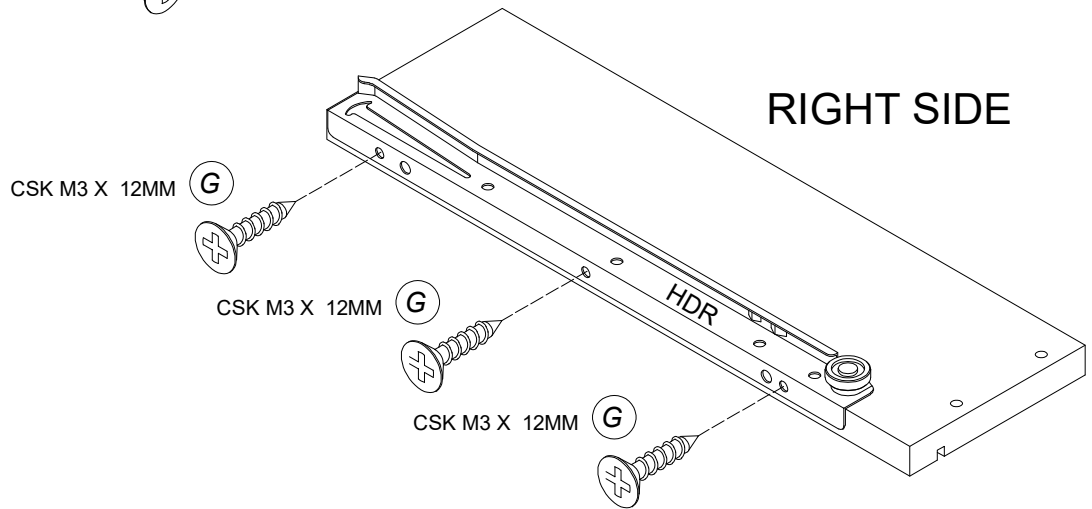

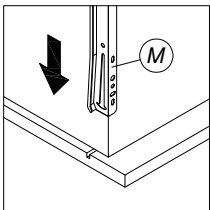

STEP 13

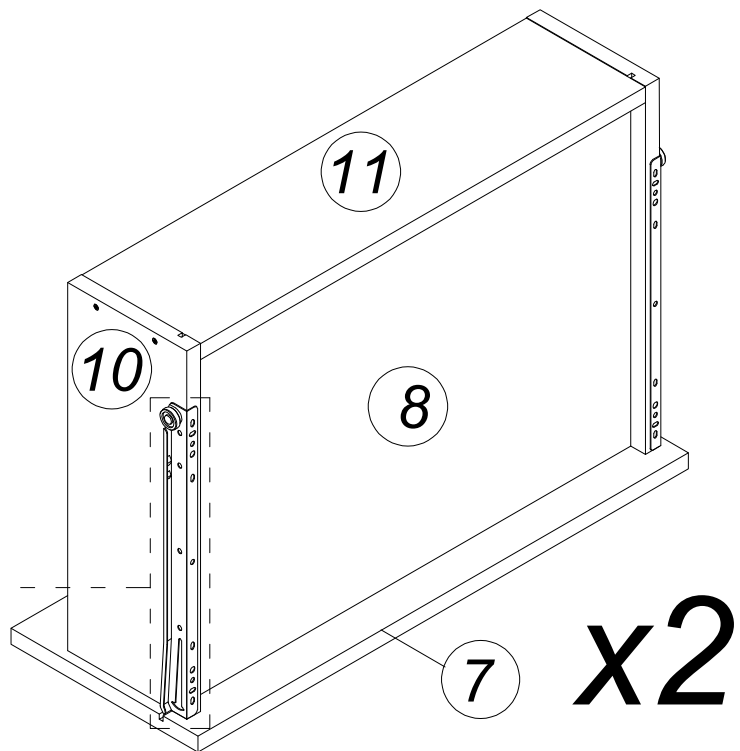
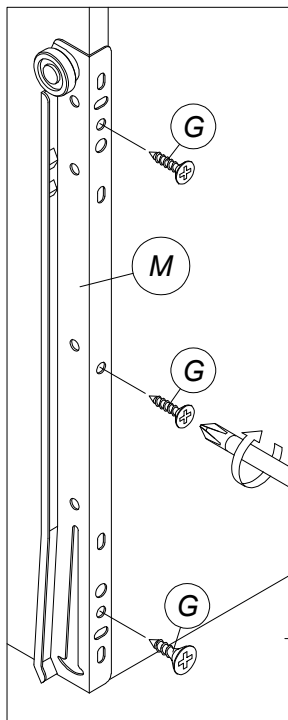

MAKE SURE TO PUSH (M)
TOWARD DRAWER FACE (7)
(NO PRE-DRILLED HOLES)

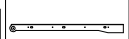

x2

M		DRAWER SLIDE SD 8879 - EV12 (300mm_1mm)	2 Pcs
G		CSK M3 X12MM	12Pcs

ASSEMBLY INSTRUCTION / INSTRUCTIONS DE MONTAGE INSTRUCCIONES DE MONTAJE

STEP 14

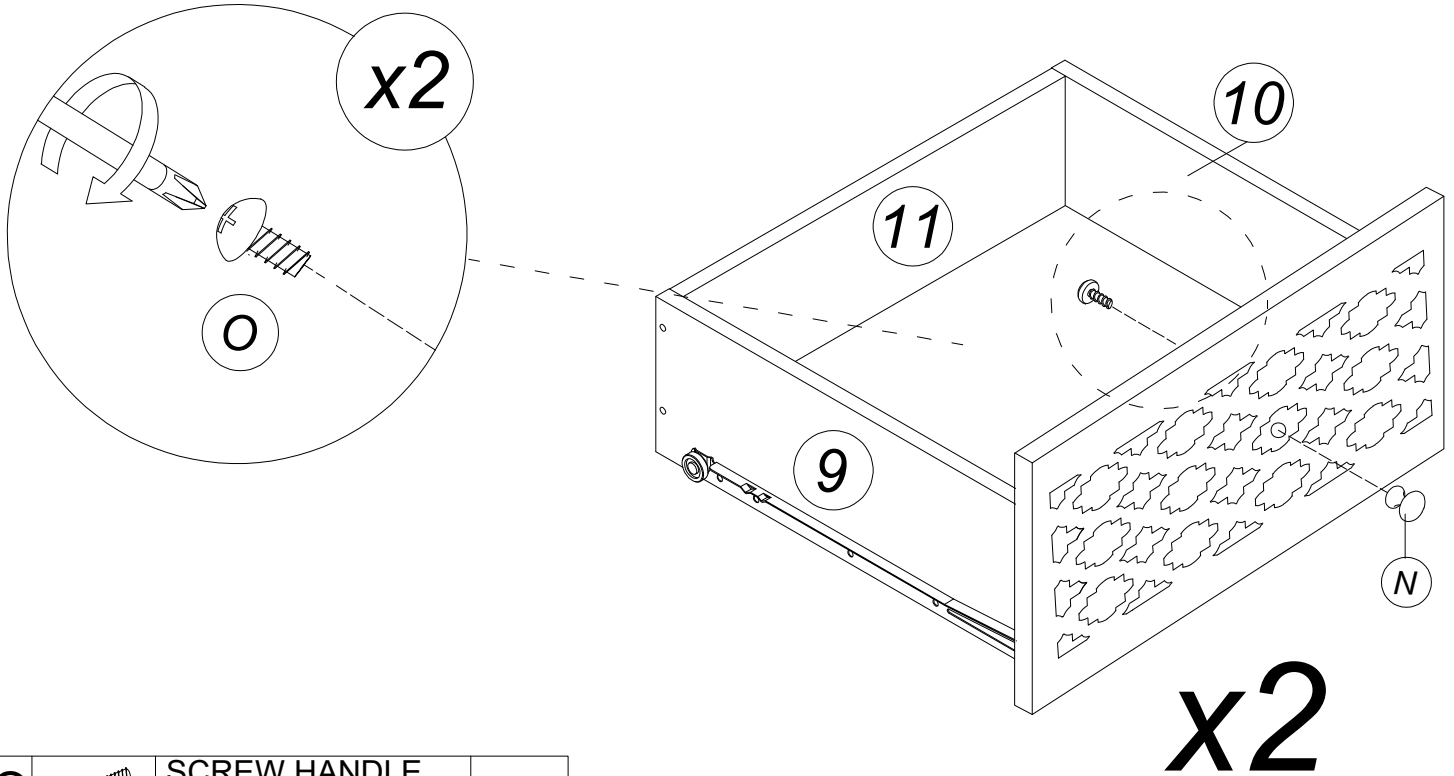

O		SCREW HANDLE M3.5 X 22mm	2Pcs
---	--	-----------------------------	------

N		KNOB SJ312 GD	2Pcs
---	---	---------------	------

STEP 15

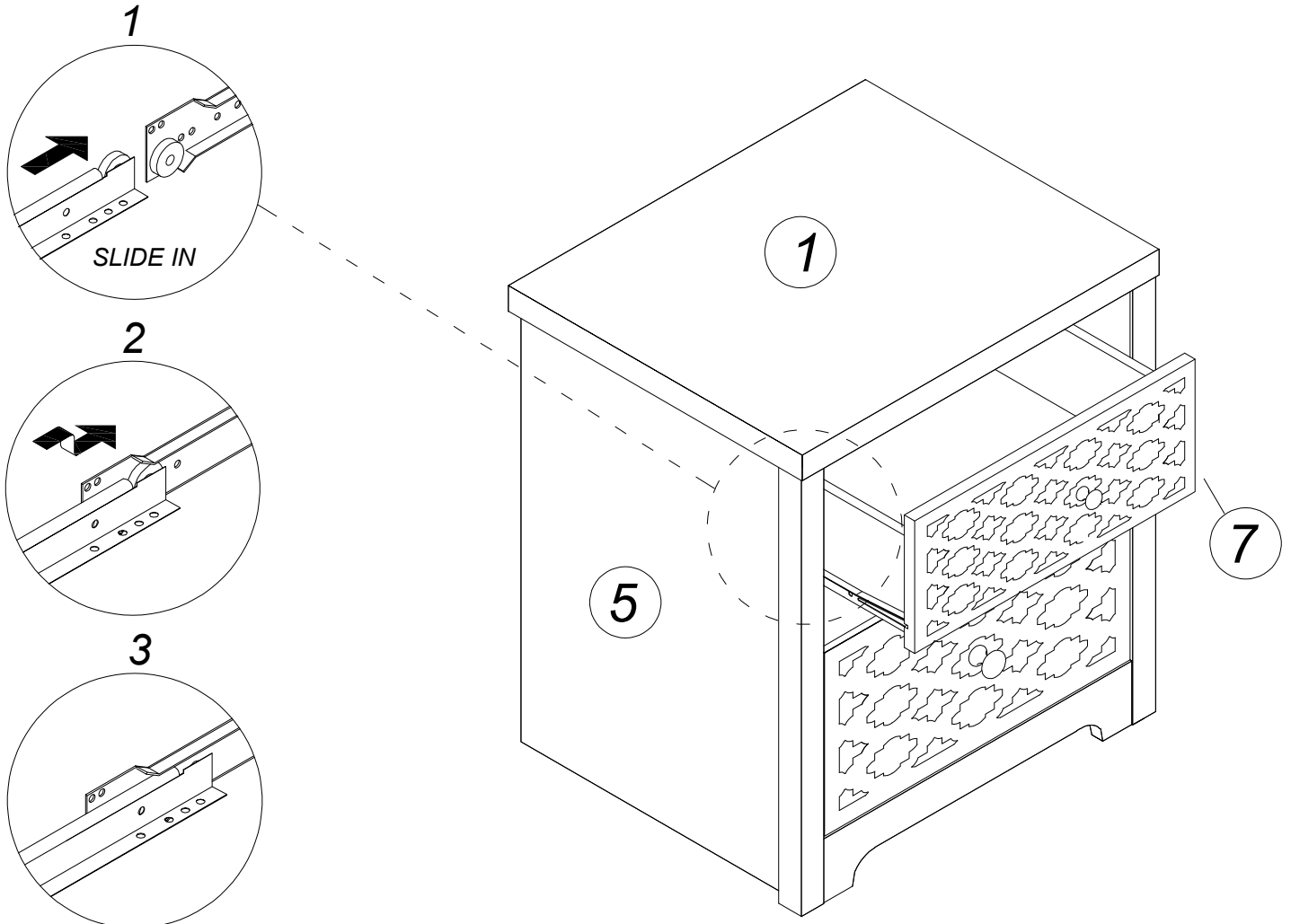

MAXIMUM LOAD / CHARGE MAXIMALE / CARGA MÁXIMA

This unit has been design to support the maximum loads. Exceeding these load limits could cause sagging, instability, product collapse, and/or serious injury.

Cette unité a été conçue pour supporter des charges maximales. Dépassez ces limites de charge pourrait provoquer un affaissement, une instabilité, un effondrement du produit et/ou des blessures graves.

Esta unidad ha sido diseñada para soportar las cargas máximas. Si se superan estos límites de carga, Podría causar flacidez, inestabilidad, colapso del producto y/o lesiones graves.

CAUTION !!!/PRUDENCE !!!/PRECAUCIÓN !!!

- *This item cannot be dragged / Cet élément ne peut pas être déplacé / Este elemento no se puede arrastrar.*
- *Please lift it to move / S'il vous plaît, soulevez-le pour bouger / Por favor, levántalo para moverte*

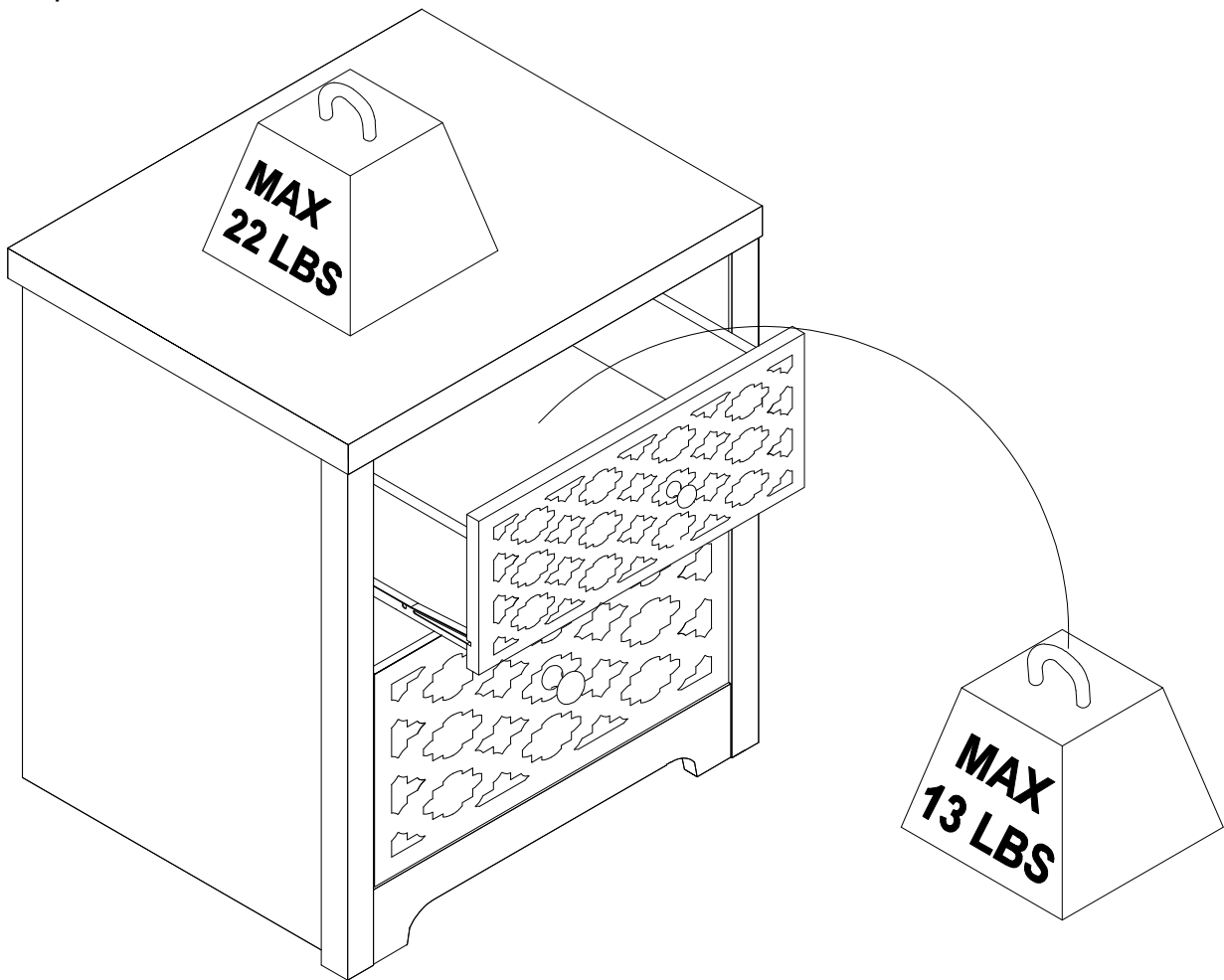

WARNING / AVERTISSEMENT / ADVERTENCIA

Serious or fatal injuries can occur from falling furniture. To prevent furniture from falling, please do:

Des blessures graves, voire mortelles, peuvent survenir en cas de chute de meubles. Pour éviter que des meubles ne tombent, veuillez procéder comme suit :

La caída de muebles puede provocar lesiones graves o fatales. Para evitar la caída de muebles, haga lo siguiente:

- Install the tipover restraint provided / Installez le dispositif de retenue anti-basculement fourni / Instale el dispositivo de retención antivuelco provisto.
- Place heaviest items in the lowest rack Placez les articles les plus lourds dans le panier le plus bas / Coloque los artículos más pesados en el estante más bajo.
- Do not let children climb or hang on drawers, doors, or shelves / Ne laissez pas les enfants grimper ou s'accrocher aux tiroirs, aux portes ou aux étagères / No permita que los niños se suban o se cuelguen de cajones, puertas o estantes.

The use of tip over restraints may only reduce and not eliminate the risk of failing furniture.

L'utilisation de dispositifs de retenue anti-basculement peut seulement réduire et non éliminer le risque de défaillance des meubles.

El uso de dispositivos antivuelco solo puede reducir, pero no eliminar, el riesgo de que los muebles se caigan.