

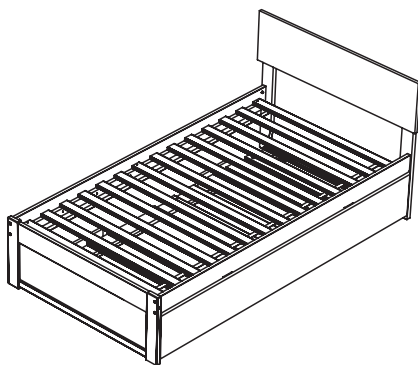

TRUNDLE BED

ASSEMBLY INSTRUCTIONS

Before assembling your trundle bed, please read through these instructions carefully, familiarize yourself with the different parts.

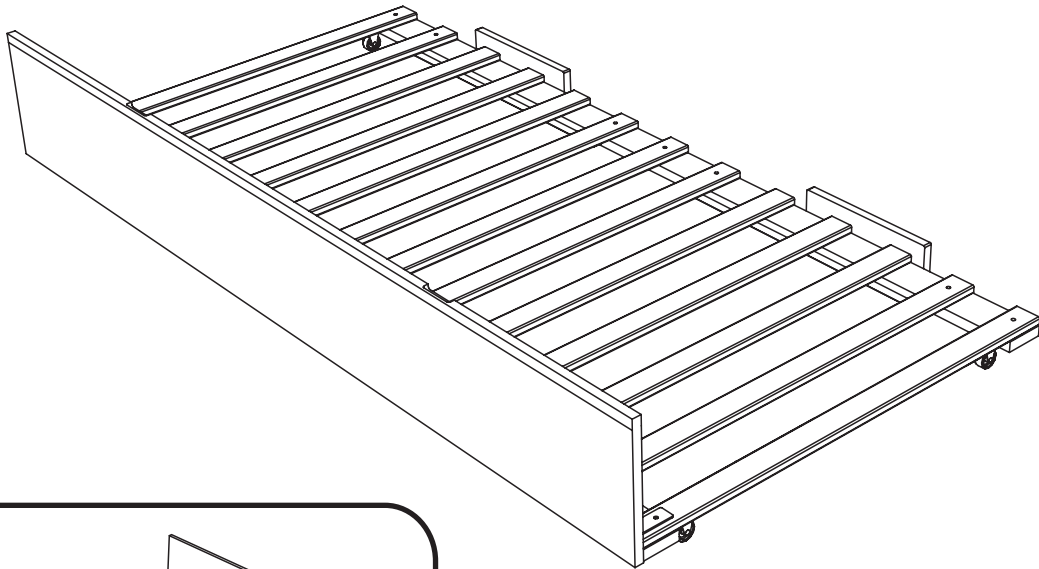

BED WITH FLAT PANEL TRUNDLE BED



Adult Assembly

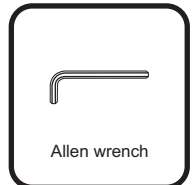

Allen wrench

HARDWARE

NOTE : WE INCLUDE SPARE HARDWARE IN CASE THE ALLEN WRENCH, JCB OR BARREL NUT ARE DAMAGED DURING ASSEMBLY.

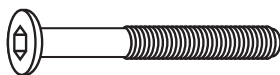

- A** JCB M6 X 2 3/8" (60mm) - 4 pcs
Spare - 1 pc

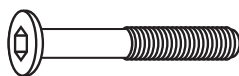

- B** JCB M6 X 1 1/2" (40mm) - 17 pcs
Spare - 2 pcs



- C** JCB M6 X 5/8" (15mm) - 6 pcs
Spare - 2 pcs
Fix L Bracket to Front Panel



- D** Barrel Nut - 4 pcs
Spare - 1 pc
For JCB M6 X 2"(50mm)

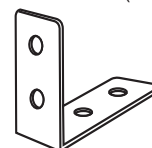

- E** L Bracket - 3 pcs



- F** Allen wrench - 1 pc
Spare - 1 pc

PARTS LIST

01	HARDWARE	1 BOX	05	SIDE CROSS RAIL	2 PCS
02	FRONT PANEL	1 PC	06	CENTER CROSS RAIL	1 PC
03	FRONT RAIL	1 PC	07	BACK BOARD	2 PCS
04	BACK RAIL	1 PC	08	SLAT	2 SET

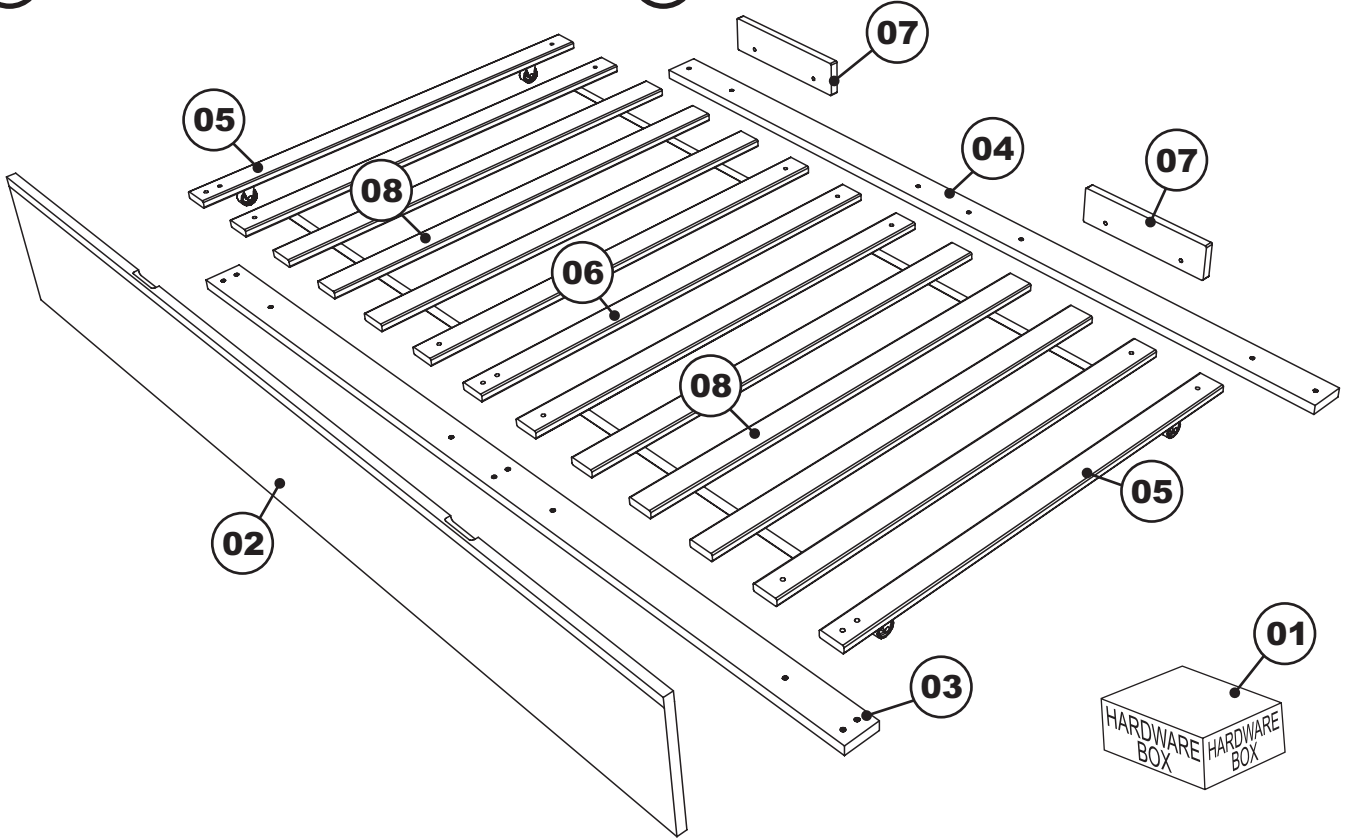

STEP 1

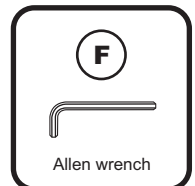
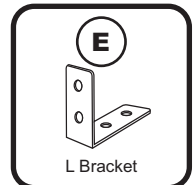
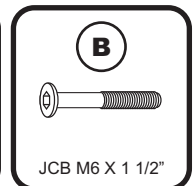
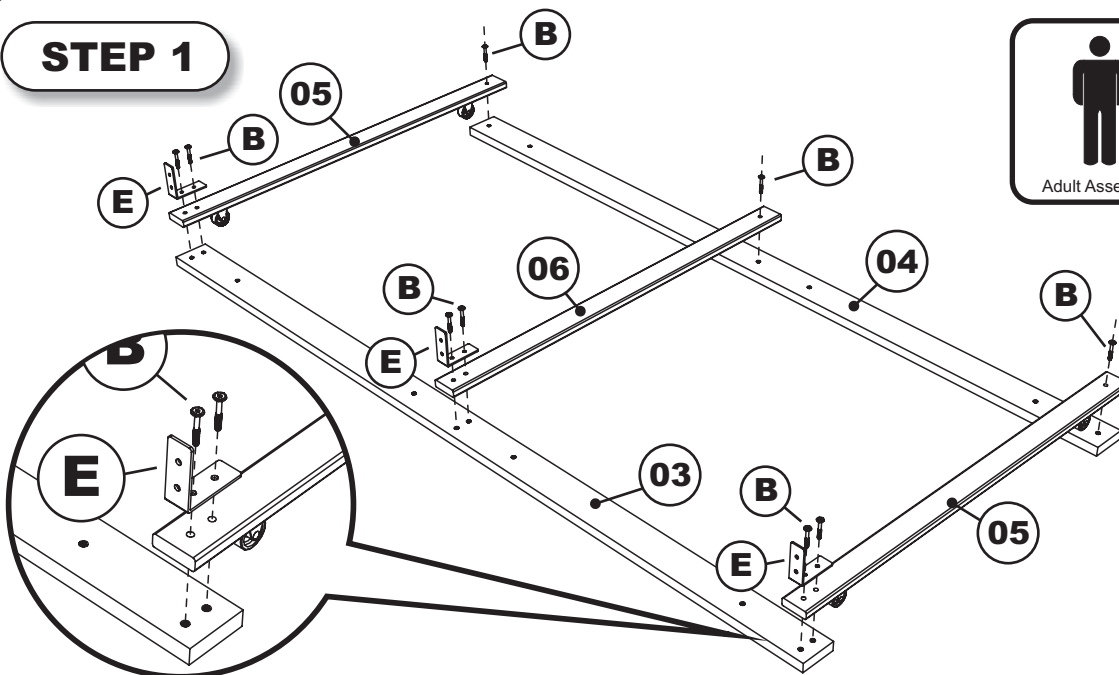

Attach the side cross rail (05) center cross rail (06) to the front and back rail (03)(04), using L bracket (E), JCB M6 X 1 1/2"(B). Tighten with the Allen wrench (F).

STEP 2

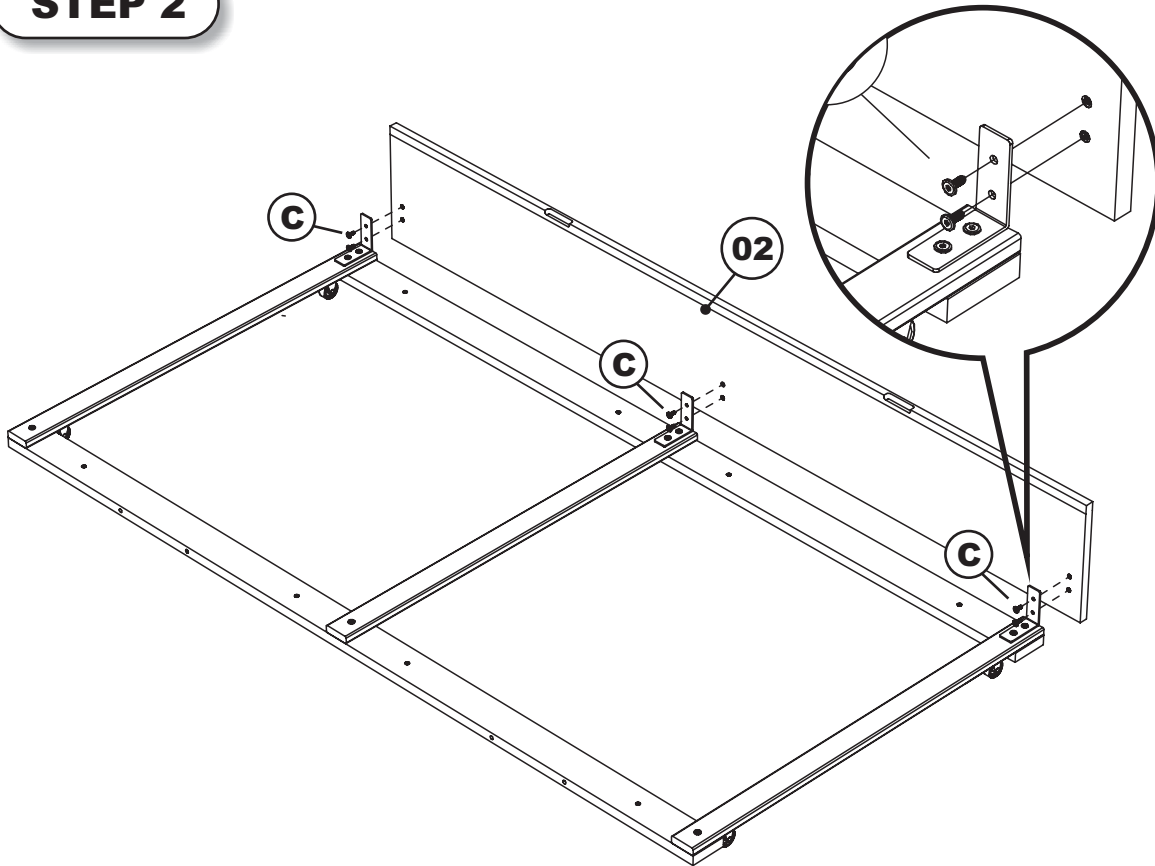

Adult Assembly

C



JCB M6 X 5/8"

F



Allen wrench

Attach the front panel (02) to the rail assemblies as shown, using JCB M6 X 5/8" (C).
Tighten with the Allen wrench (F).

STEP 3

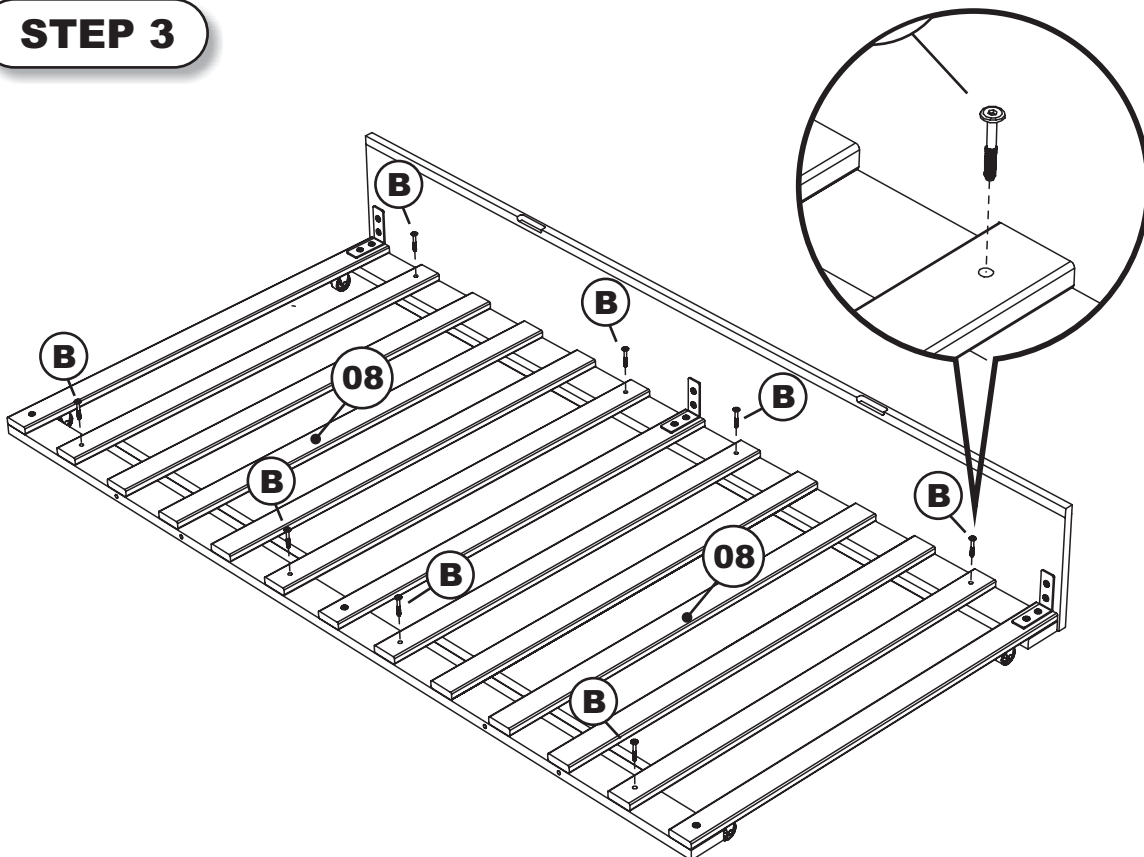

Adult Assembly

B

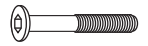

JCB M6 X 1 1/2"

F



Allen wrench

Lay the slat kit (08) onto the rail assemblies as shown, using JCB M6 X 1 1/2" (B).
Tighten with the Allen wrench (F).

STEP 4

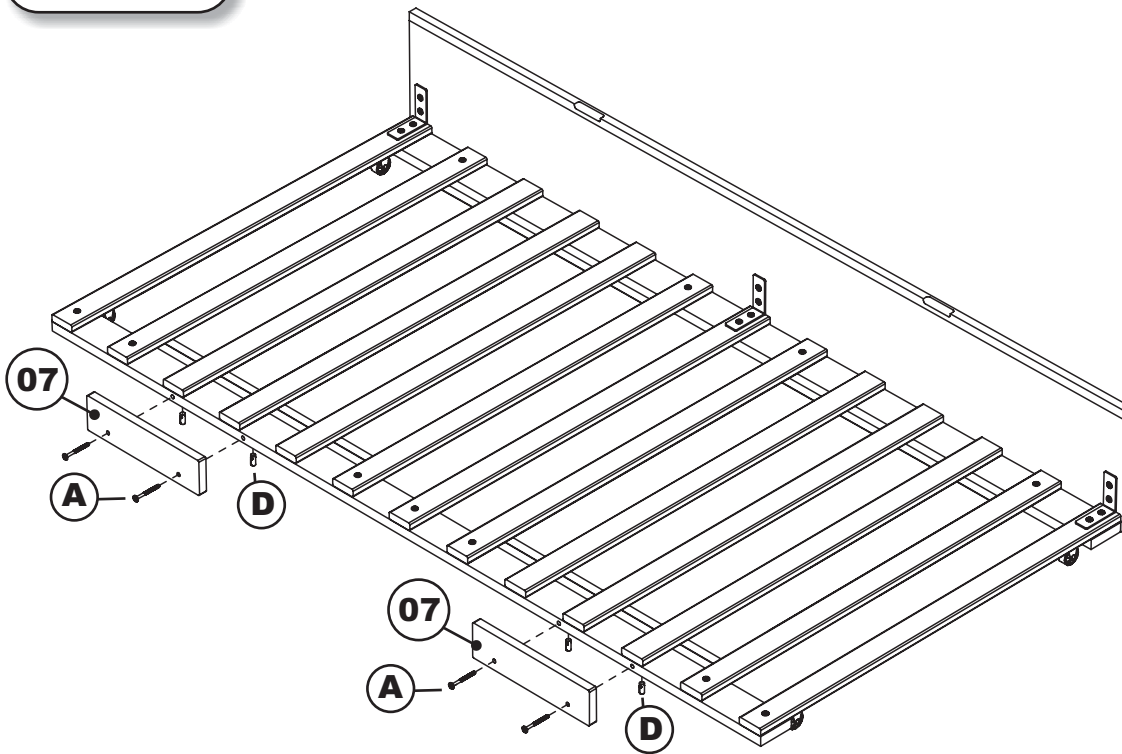

Adult Assembly

A



JCB M6 X 2 3/8"

D



Barrel Nut

F



Allen wrench

Attach the back boards (07) to the rail assemblies as shown. Using JCB M6 X 2 3/8"(A) barrel nut (D), tighten with the Allen wrench (F)

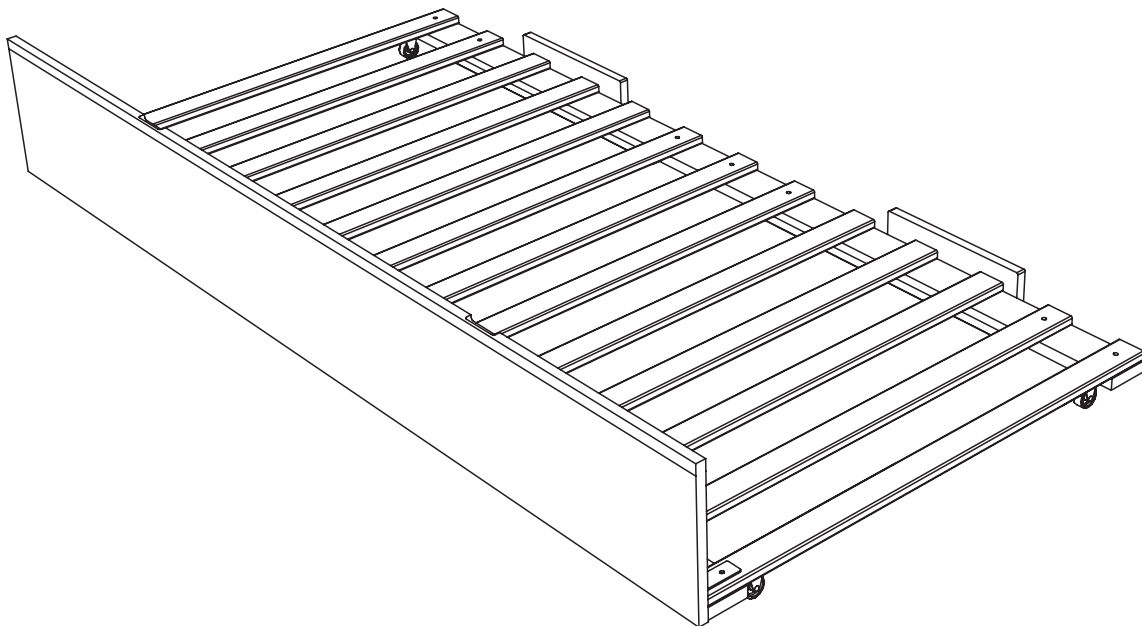

Congratulations !

Your Trundle Bed is now ready for use.

We recommend that you recheck that all screws are tight, and that all parts are secure before use and periodically to ensure lasting Safety.