

GA7009

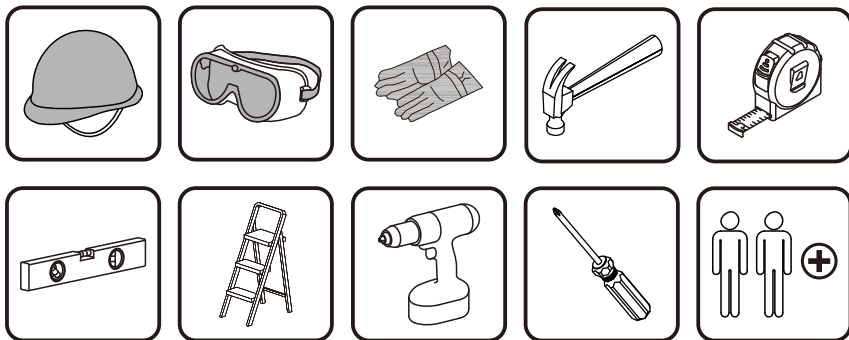

Tools Recommended

PART LIST (BOX 3)

PLATES

13 X4

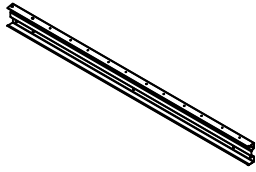

14 X4

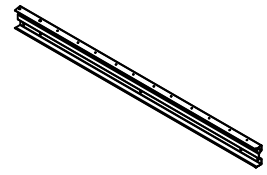

21L X2

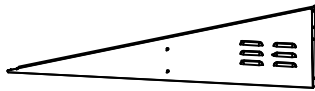

21R X2

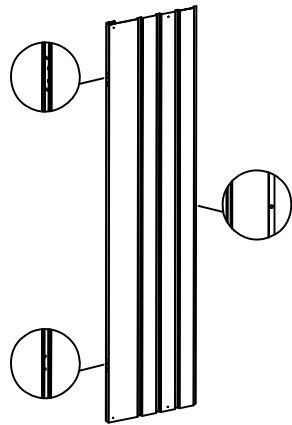
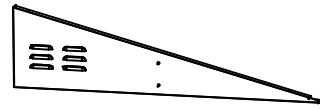

DLA X1

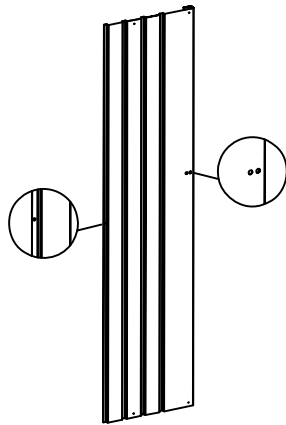

DLB X1

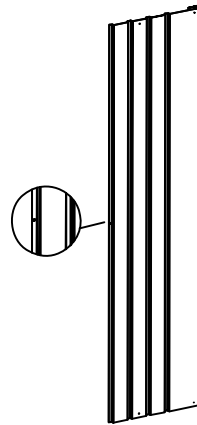

DRA X1

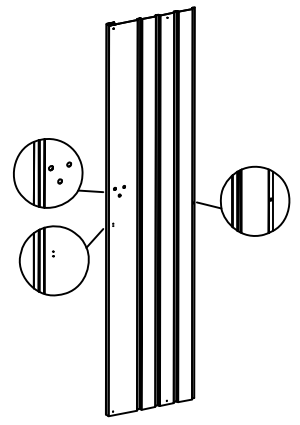

DRB X1

17 X4

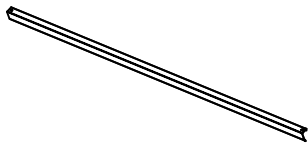

DX2 X4

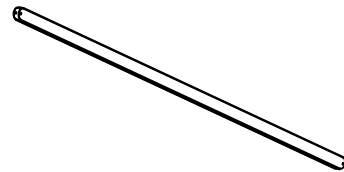

P1 X2

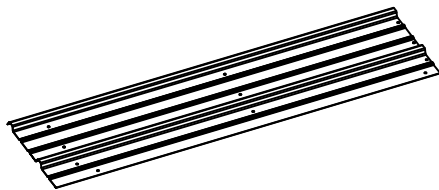

P2 X2

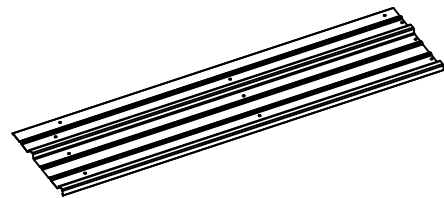



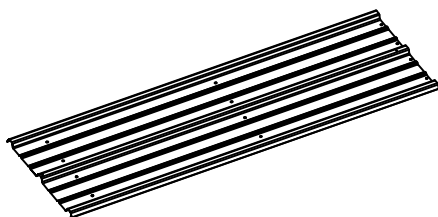



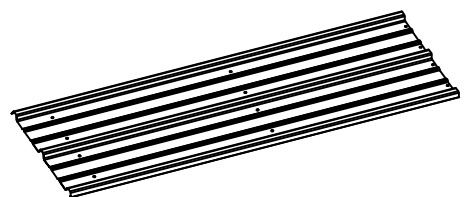



P3 X8

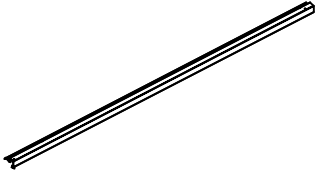
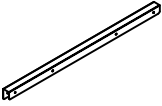

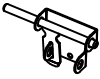
P3A X2

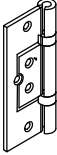

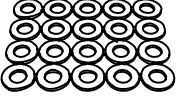
PLATES

		 19 X2	
 C4L X2	 C5 X4	 15 X2	
 20 X4	 C4R X2	 16 X2	
 DG X1	 DF X1	 DC X2	 DH X4
 V1 X108	 V2 X185	 GC X4	 GE X2

STANDARD

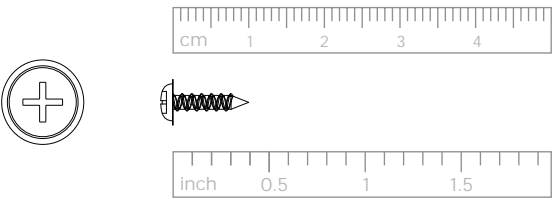
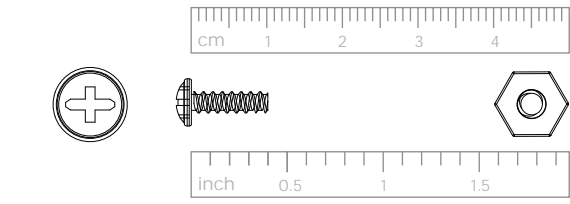
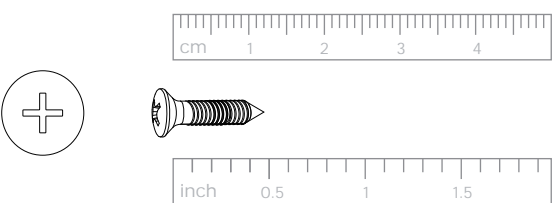
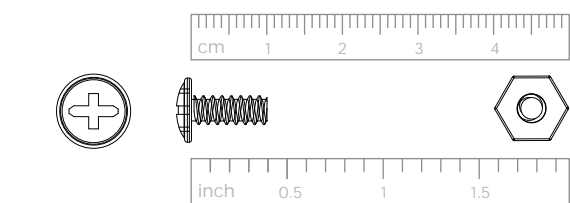
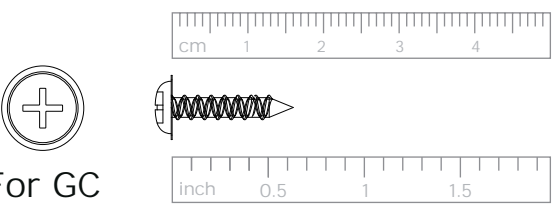
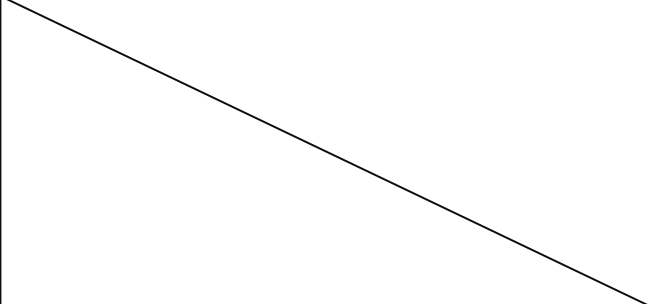



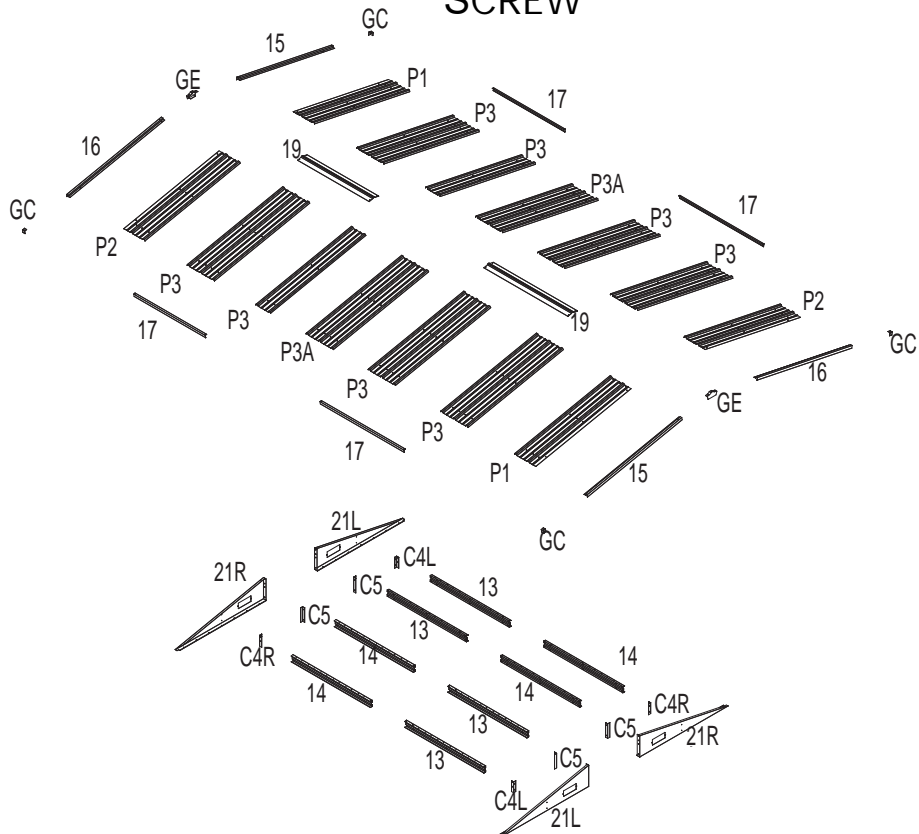

 <p>F1(X247) M4*10</p>	 <p>F2(X50) M4*10</p>
 <p>F3(X24) M5*12</p>	 <p>F4(X5) M6*10</p>
 <p>For GC F5(X4) M4*16</p>	

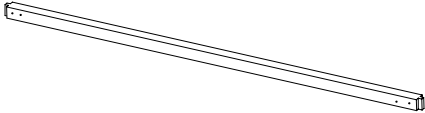

SCREW





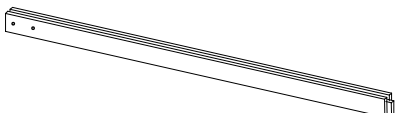
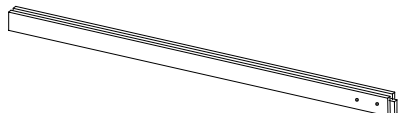
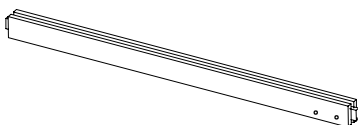
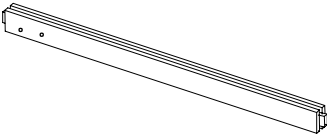
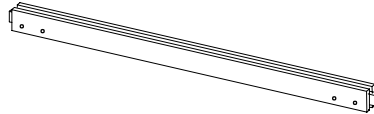

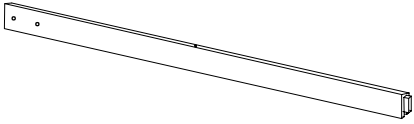
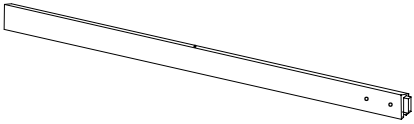

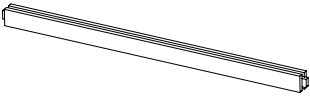
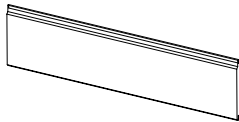
Please remove the shipping protective film of the product before installation

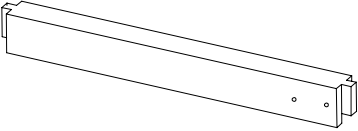
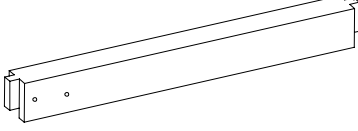
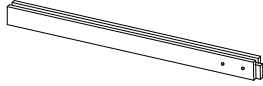
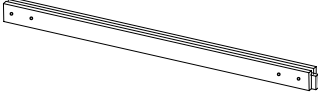
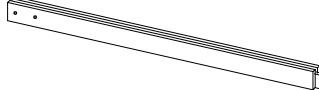
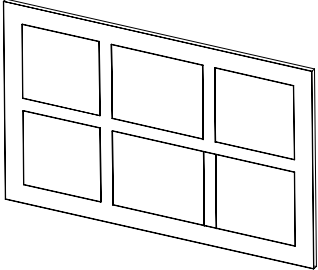

PART LIST (BOX 2)

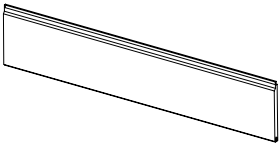
 1657*45*45mm	① X4	 1156*30*30mm	② X2	 1657*40*30mm	⑤ X1
 1657*40*30mm	AA X1	 1657*40*30mm	⑩ X2	 1672*40*30mm	⑪ X2
 1595*40*30mm	⑫ X2	 1680*40*30mm	⑳ X1	 1680*40*30mm	㉓ X1
 830*40*30mm	㉔ X2	 830*40*30mm	㉕ X2	 830*40*30mm	㉖ X2

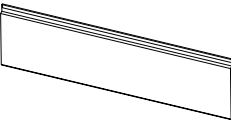

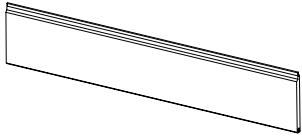
<div data-bbox="448 226 572 282" data-label="Text"> <p>④④ X1</p> </div>  <div data-bbox="129 624 331 667" data-label="Text"> <p>1680*65*30mm</p> </div>	<div data-bbox="895 226 1019 282" data-label="Text"> <p>④⑤ X1</p> </div>  <div data-bbox="576 624 778 667" data-label="Text"> <p>1680*65*30mm</p> </div>	<div data-bbox="1342 226 1466 282" data-label="Text"> <p>④⑥ X1</p> </div>  <div data-bbox="1023 624 1214 667" data-label="Text"> <p>830*65*30mm</p> </div>
<div data-bbox="448 672 572 728" data-label="Text"> <p>④⑦ X1</p> </div>  <div data-bbox="129 1070 320 1113" data-label="Text"> <p>830*65*30mm</p> </div>	<div data-bbox="895 672 1019 728" data-label="Text"> <p>④⑧ X4</p> </div>  <div data-bbox="576 1070 767 1113" data-label="Text"> <p>830*40*30mm</p> </div>	<div data-bbox="1342 672 1466 728" data-label="Text"> <p>②⑤ X84</p> </div>  <div data-bbox="1023 1070 1198 1113" data-label="Text"> <p>829*97*9mm</p> </div>

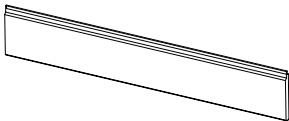
PART LIST (BOX 3)

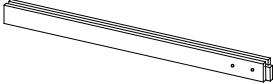
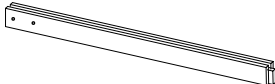
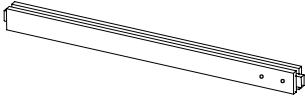
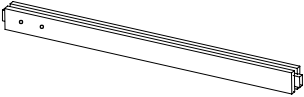
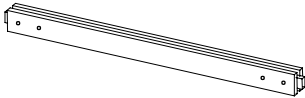
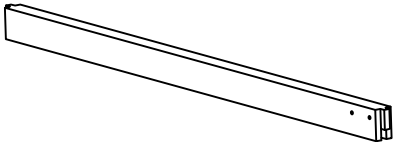
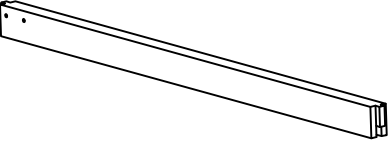
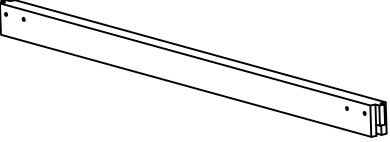
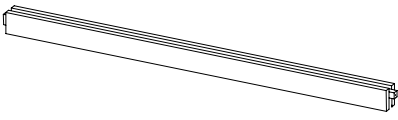
<p style="text-align: right;">③ X1</p>  <p>869.5*40*30mm</p>	<p style="text-align: right;">④ X1</p>  <p>869.5*40*30mm</p>	<p style="text-align: right;">⑥ X1</p>  <p>965*40*30mm</p>
<p style="text-align: right;">⑦ X4</p>  <p>965*40*30mm</p>	<p style="text-align: right;">⑧ X1</p>  <p>965*40*30mm</p>	<p style="text-align: right;">⑨ X2</p>  <p>827*318mm</p>
<p style="text-align: right;">⑳ X2</p>  <p>868.5*65*9mm</p>	<p style="text-align: right;">㉓ X32</p>  <p>868.5*97*9mm</p>	<p style="text-align: right;">㉔ X6</p>  <p>829*65*9mm</p>
<p style="text-align: right;">㉕ X4</p>  <p>829*97*9mm</p>	<p style="text-align: right;">㉖ X3</p>  <p>964*65*9mm</p>	<p style="text-align: right;">㉗ X48</p>  <p>964*97*9mm</p>

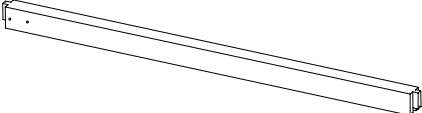
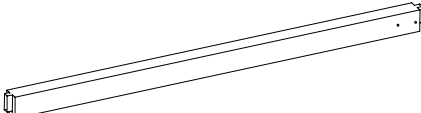
<p style="text-align: right;">②⑧ X2</p>  <p>868.5*67*9mm</p>	<p style="text-align: right;">②⑨ X6</p>  <p>829*67*9mm</p>	<p style="text-align: right;">③⑩ X3</p>  <p>964*67*9mm</p>
<p style="text-align: right;">③③ X1</p>  <p>830*40*30mm</p>	<p style="text-align: right;">③④ X1</p>  <p>830*40*30mm</p>	<p style="text-align: right;">③⑤ X1</p>  <p>965*40*30mm</p>
<p style="text-align: right;">③⑥ X1</p>  <p>965*40*30mm</p>	<p style="text-align: right;">③⑦ X1</p>  <p>965*40*30mm</p>	<p style="text-align: right;">③⑧ X1</p>  <p>965*50*30mm</p>
<p style="text-align: right;">③⑨ X1</p>  <p>965*50*30mm</p>	<p style="text-align: right;">④⑩ X1</p>  <p>965*50*30mm</p>	<p style="text-align: right;">④⑨ X2</p>  <p>869.5*40*30mm</p>

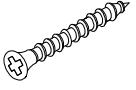
⑤① X1	⑤② X1
	
869.5*50*30mm	869.5*50*30mm

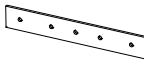
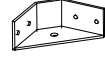
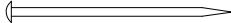
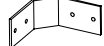
A x22+ (1) M4*50mm 	B x138+ (2) M4*20mm 	C x18 	D x4 
E x4 ø8*180mm 	F x8 		

Box 1		Box 1		Box 3	
Part#	Qty	Part#	Qty	Part#	Qty
13	4	F1	247	3	1
14	4	F2	50	4	1
21L	2	F3	24	6	1
21R	2	F4	5	7	1
DLA	1	F5	4	8	1
DLB	1			9	2
DRA	1			22	2
DRB	1			23	32
17	4			24	6
DX2	4			25	4
P1	2			26	3
P2	2			27	48
P3	8			28	2
P3A	2			29	6
19	2			30	3
C4L	2			33	1
C5	4			34	1
15	2			35	1
20	4			36	1
C4R	2			37	1
16	2			38	1
DG	1			39	1
DF	1			40	1
DC	2			49	2
DH	4			50	1
V1	108			51	1
V2	185			A	23
GC	4			B	140
GE	2			C	18
				D	4
				E	4
				F	8

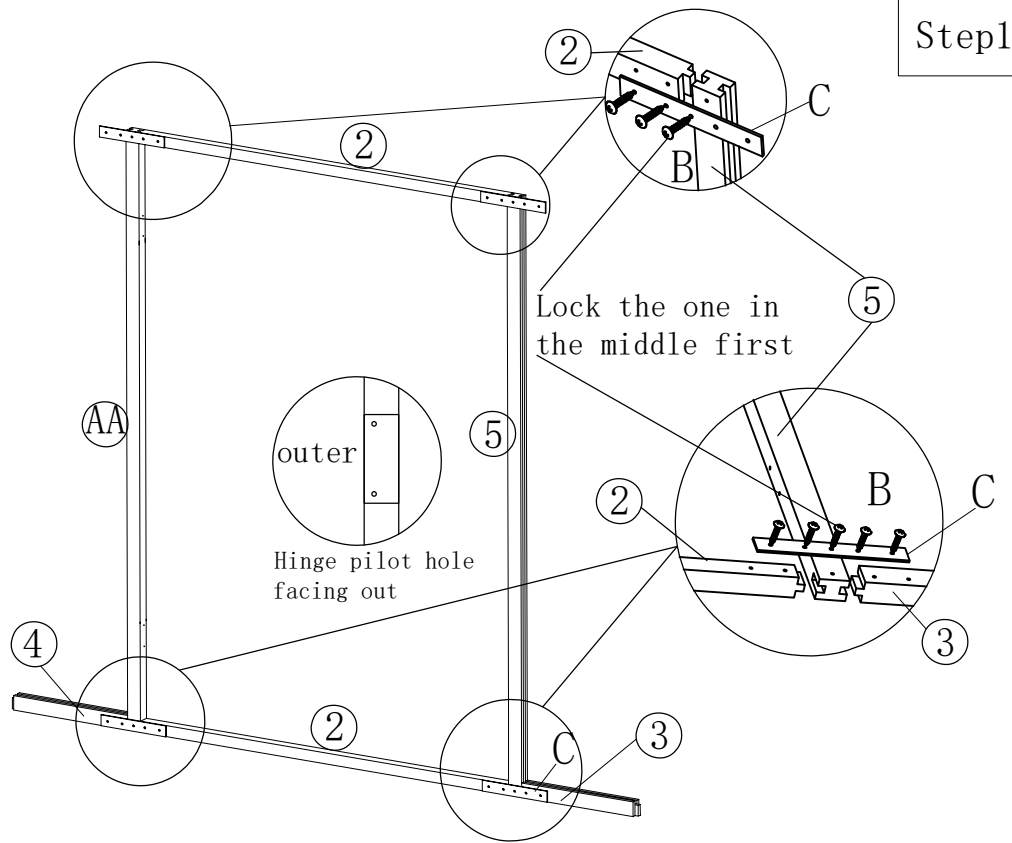
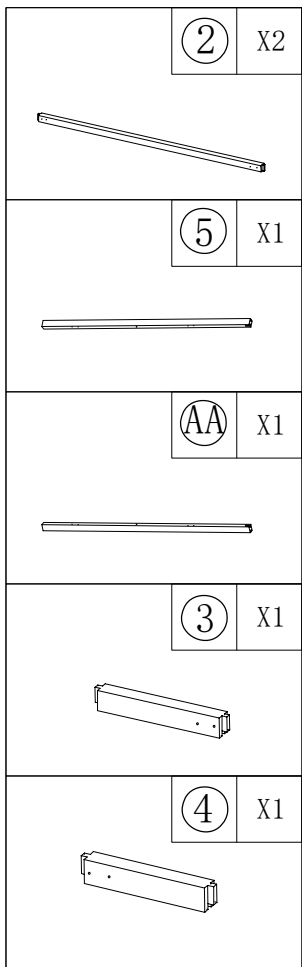

B		M4*20mm	x16
C		/	x4

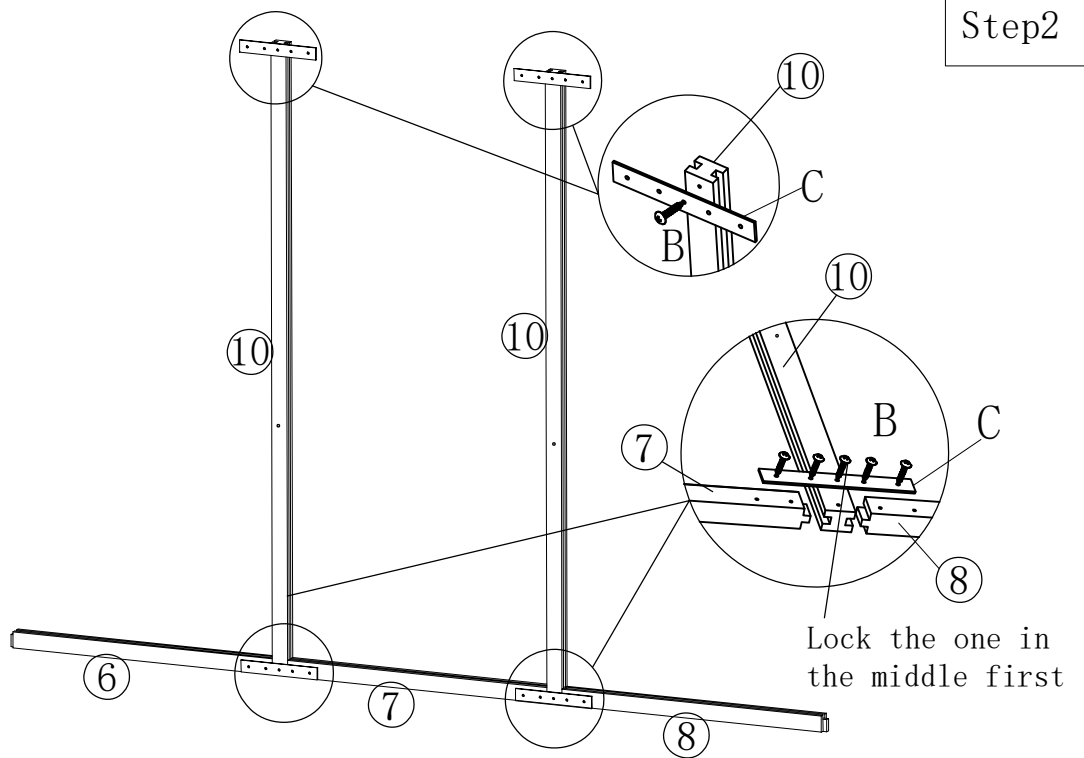
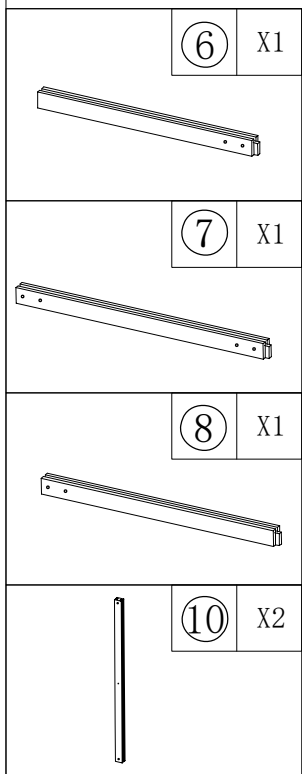

B		M4*20mm	x12
C		/	x4

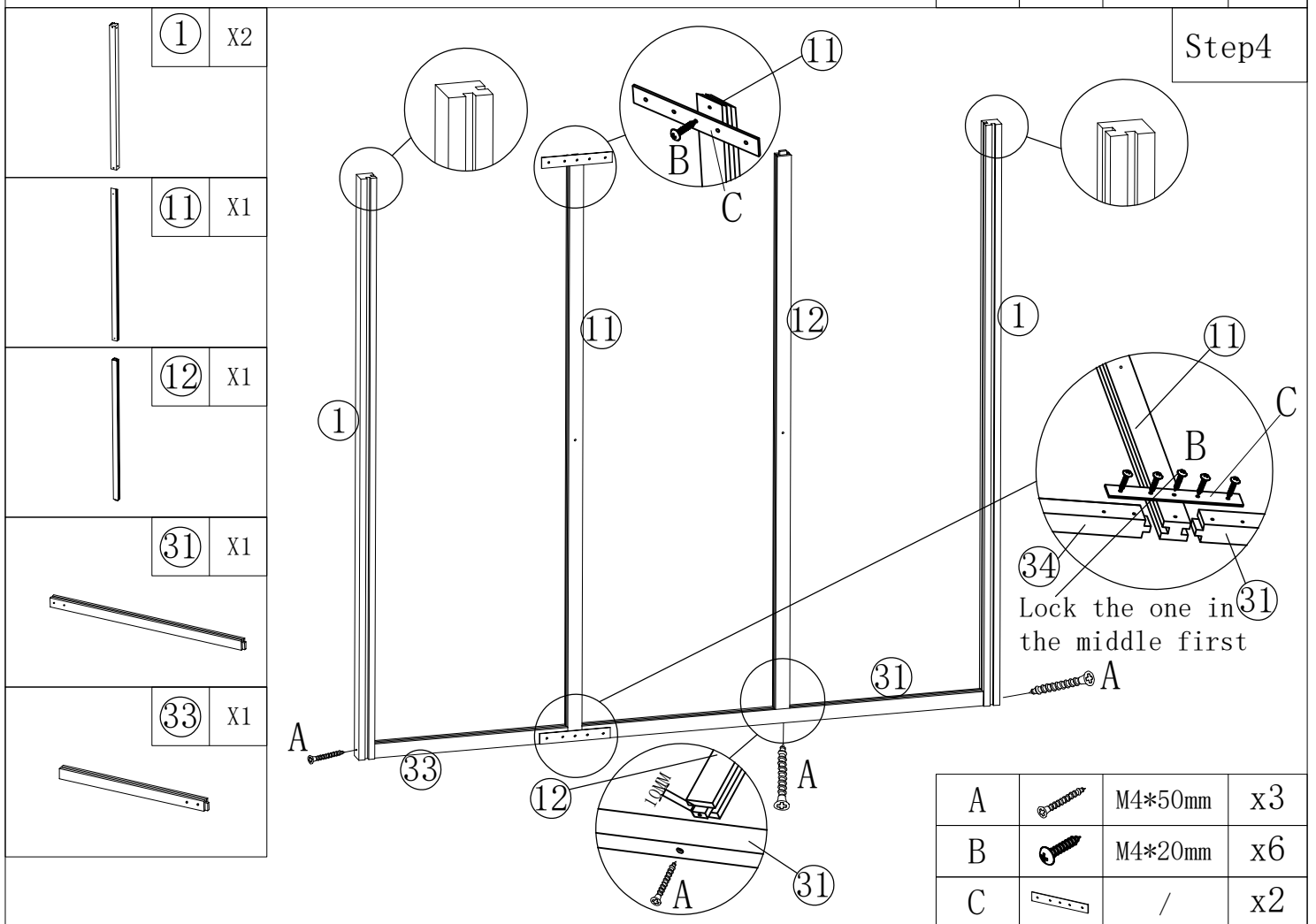
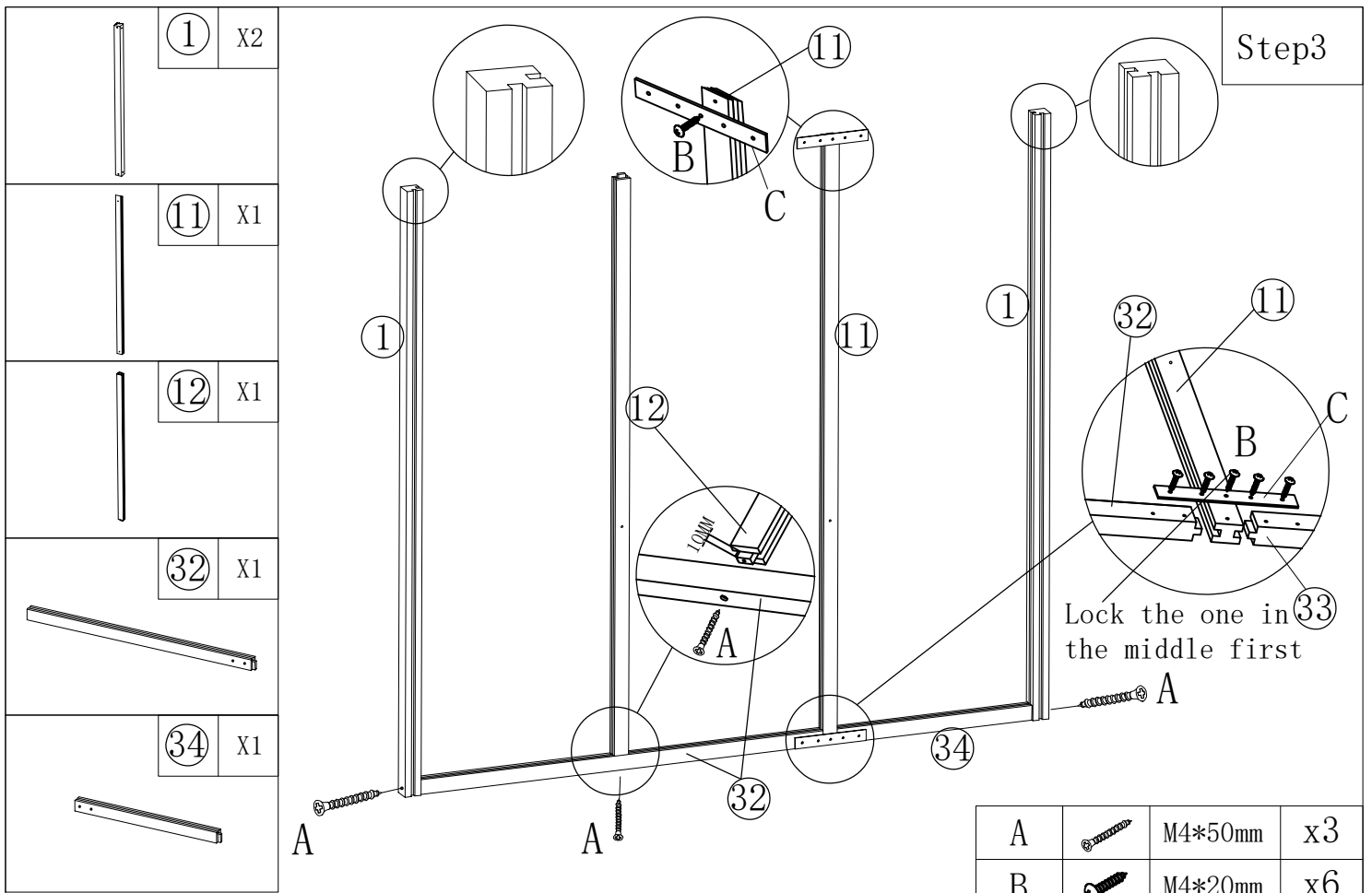

Step5

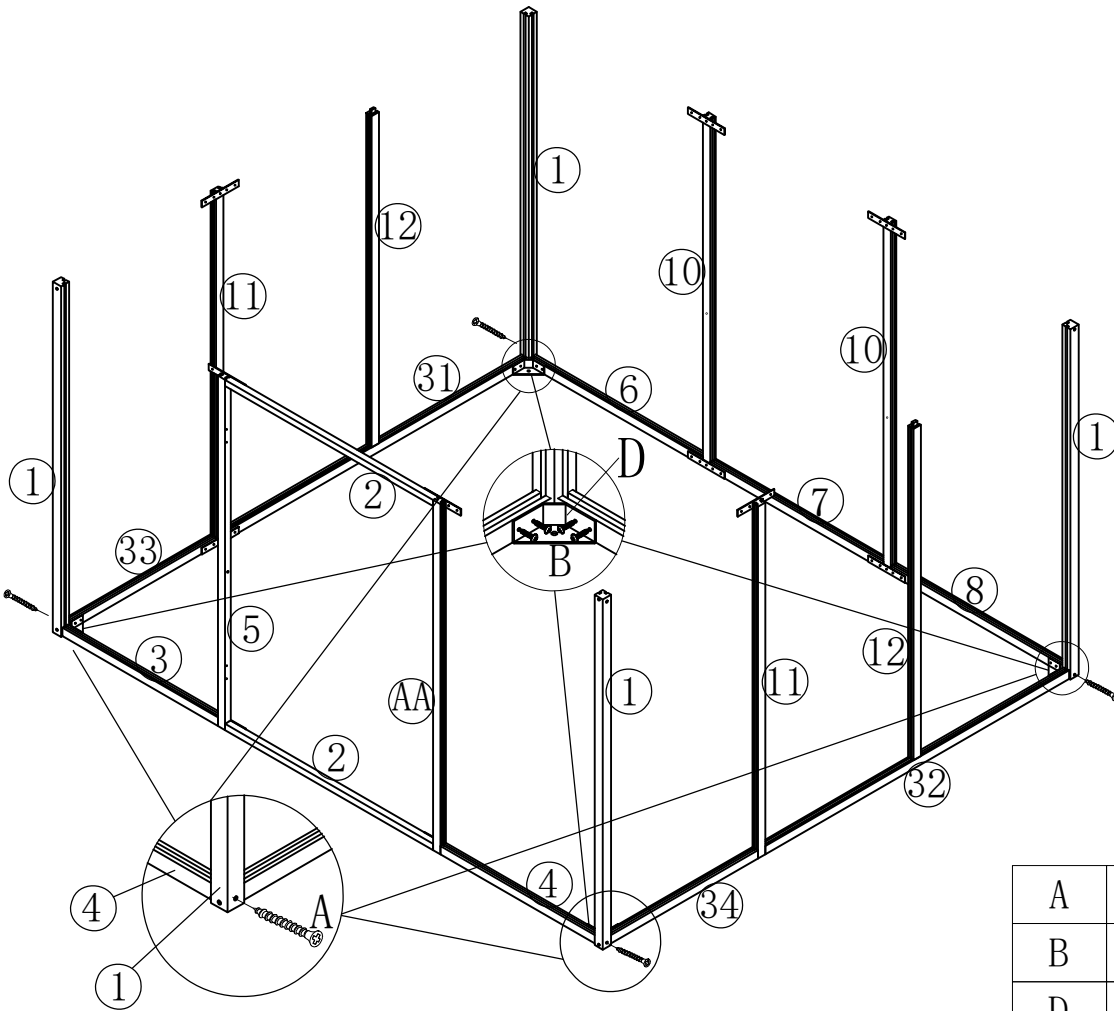

A		M4*50mm	x4
B		M4*20mm	x16
D		/	x4

Step6

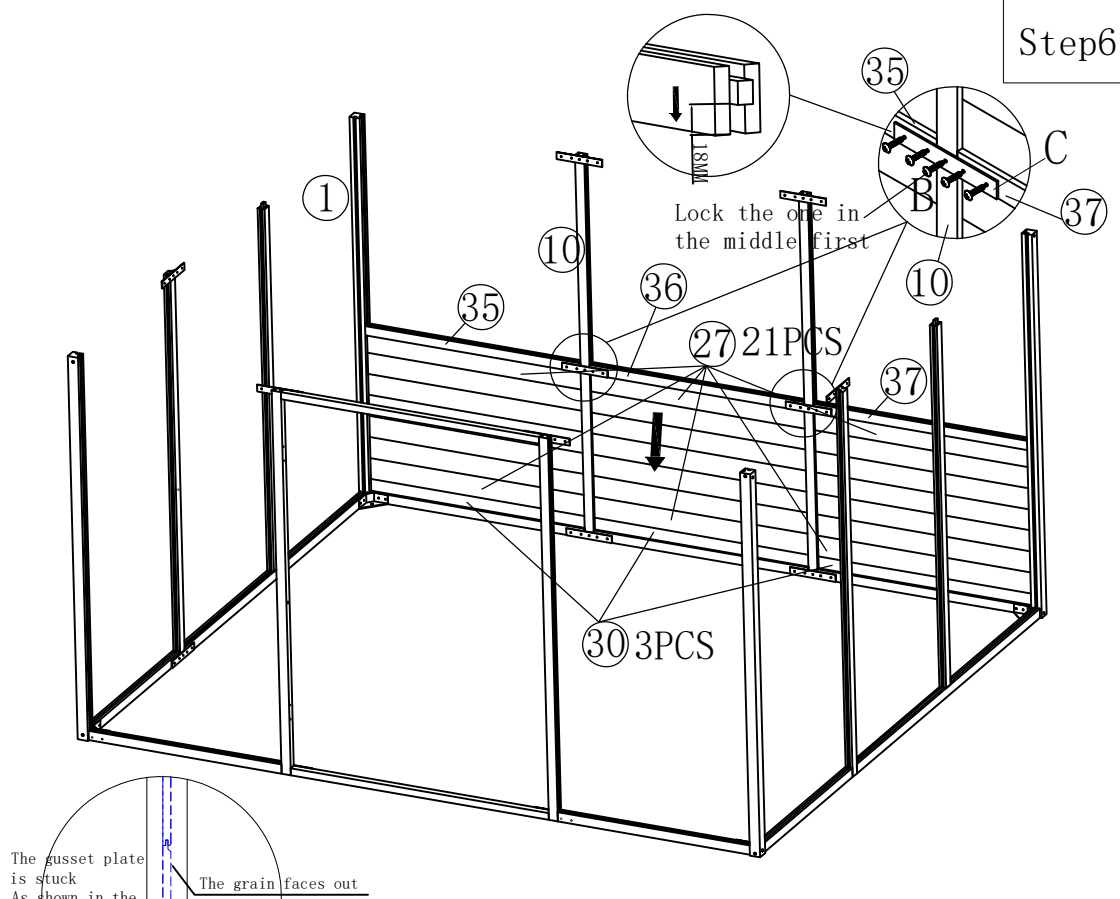
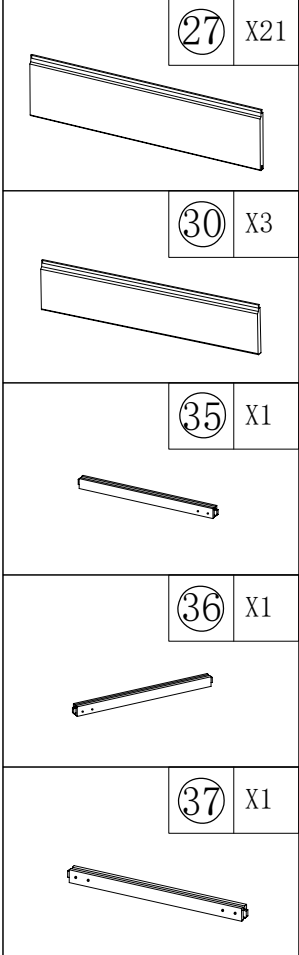

step1: insert 30 1PCS X3
 step2: insert 27 7PCS X3

B		M4*20mm	x10
C		/	x2

Step7

25 X42



29 X6



41 X2

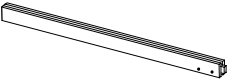

42 X2

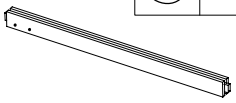

43 X2

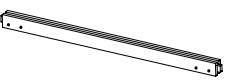

step1: insert 29 1PCS X6
step2: insert 25 7PCS X6

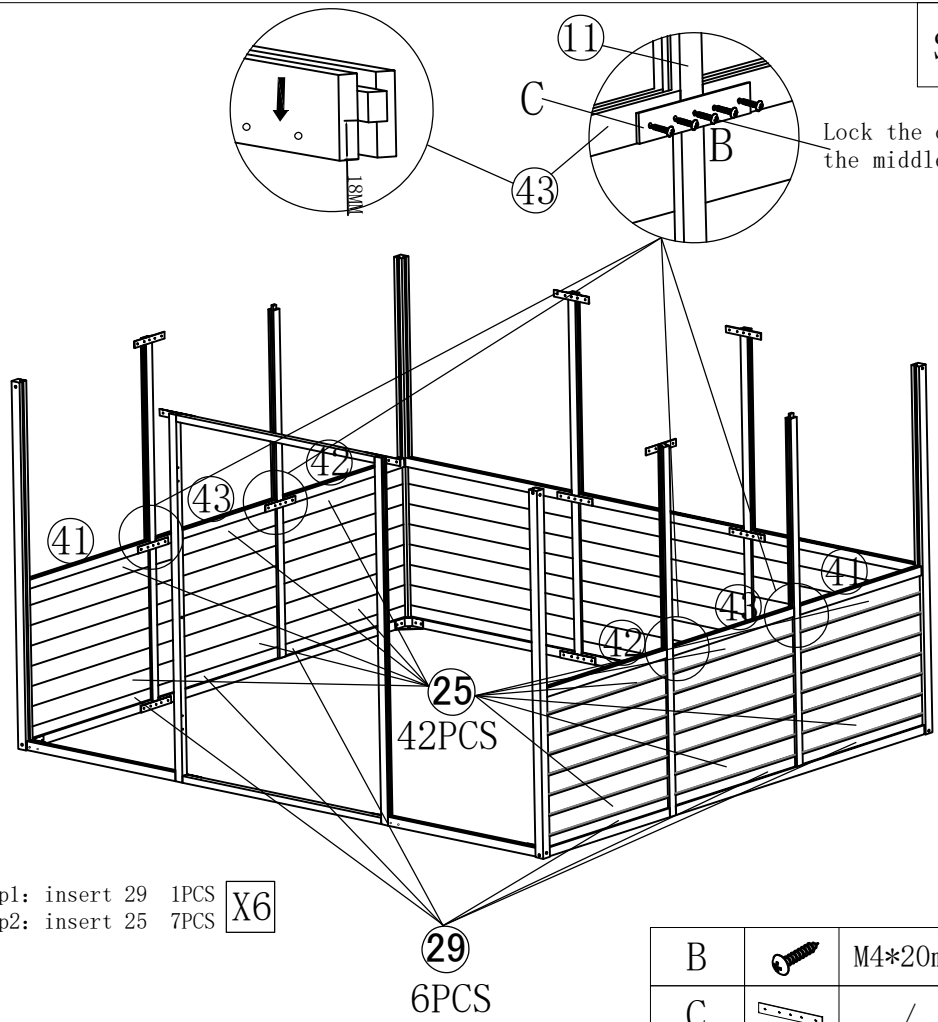

B		M4*20mm	x20
C		/	x4

Step8

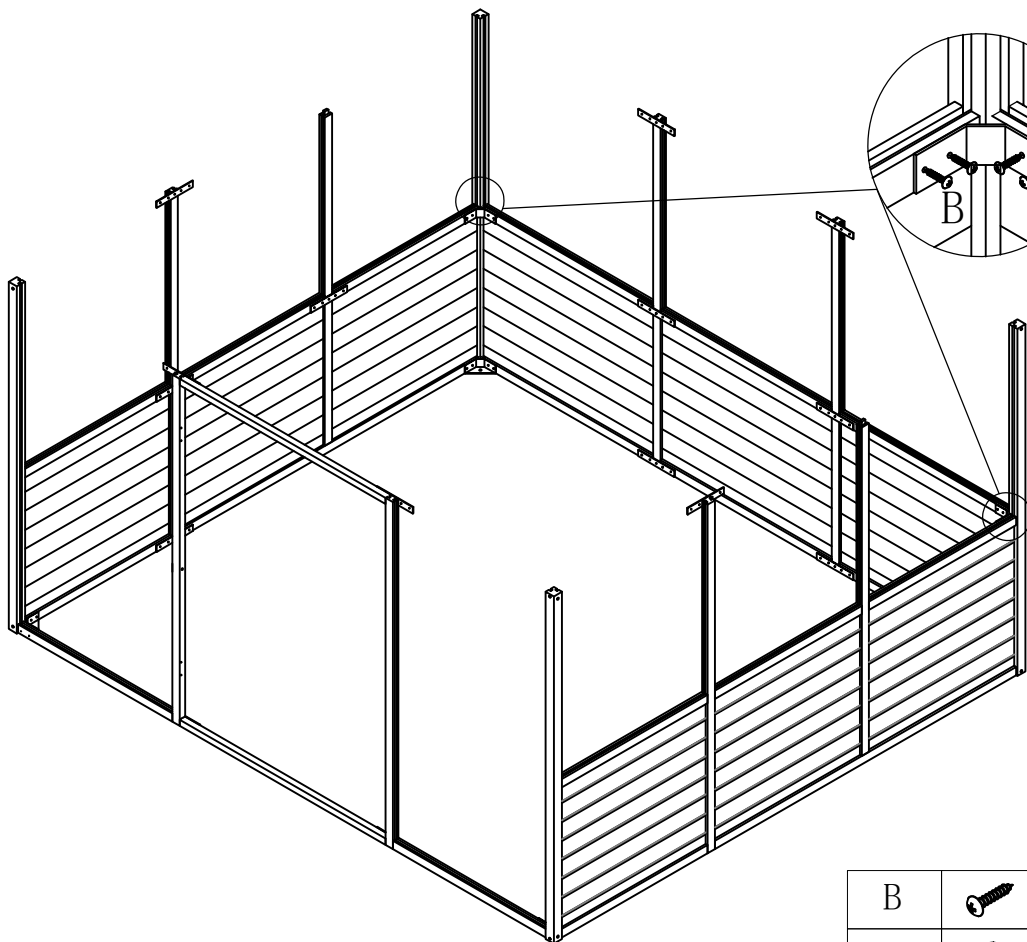

B		M4*20mm	x8
F		/	x2

Step9

23 X14

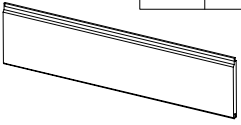

28 X2



49 X2

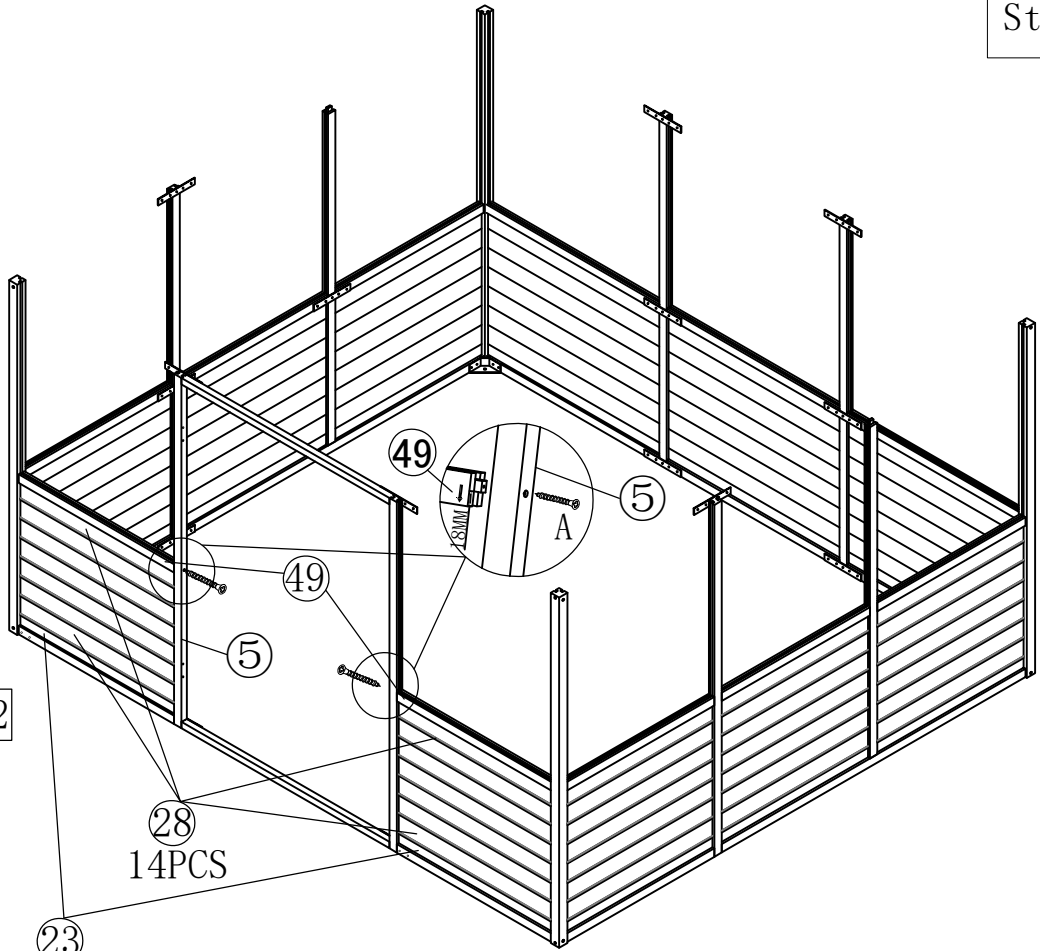
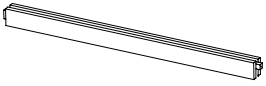

step1: insert 28 1PCS X2
step2: insert 23 7PCS

23 2PCS

28 14PCS

A		M4*50mm	x2
---	--	---------	----

Step10

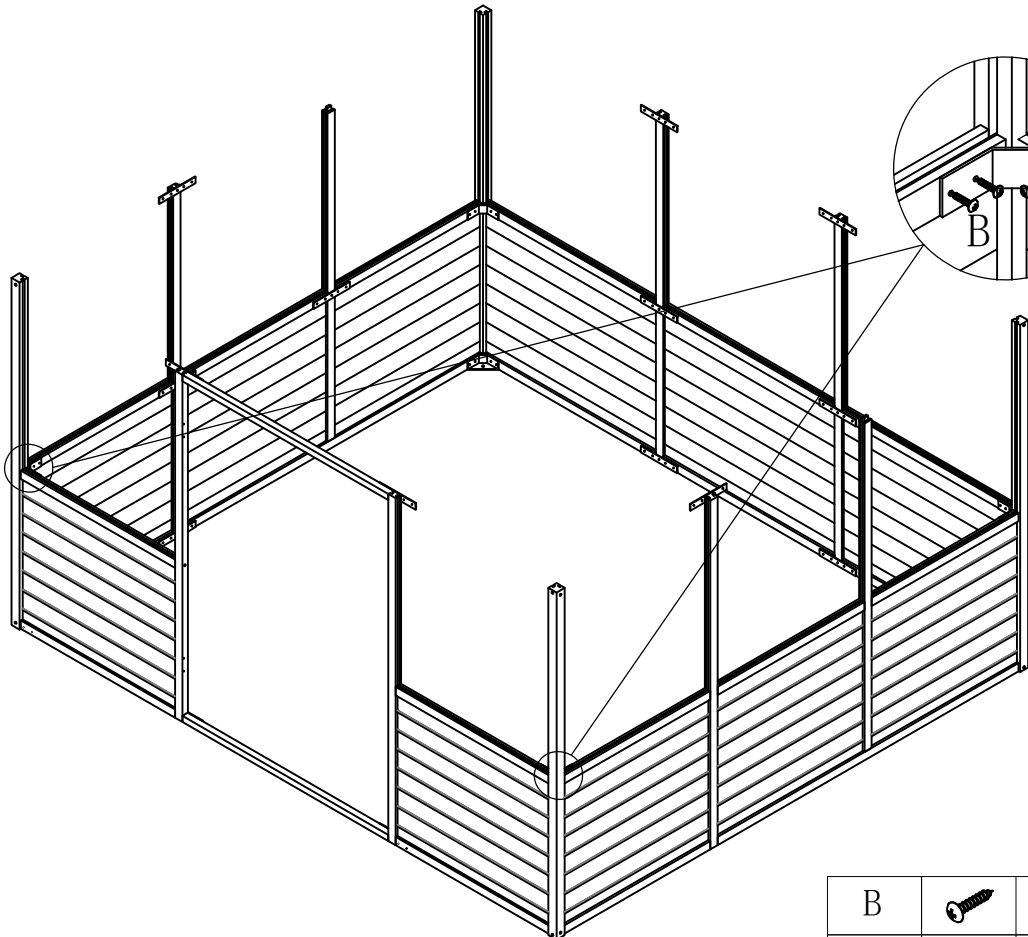



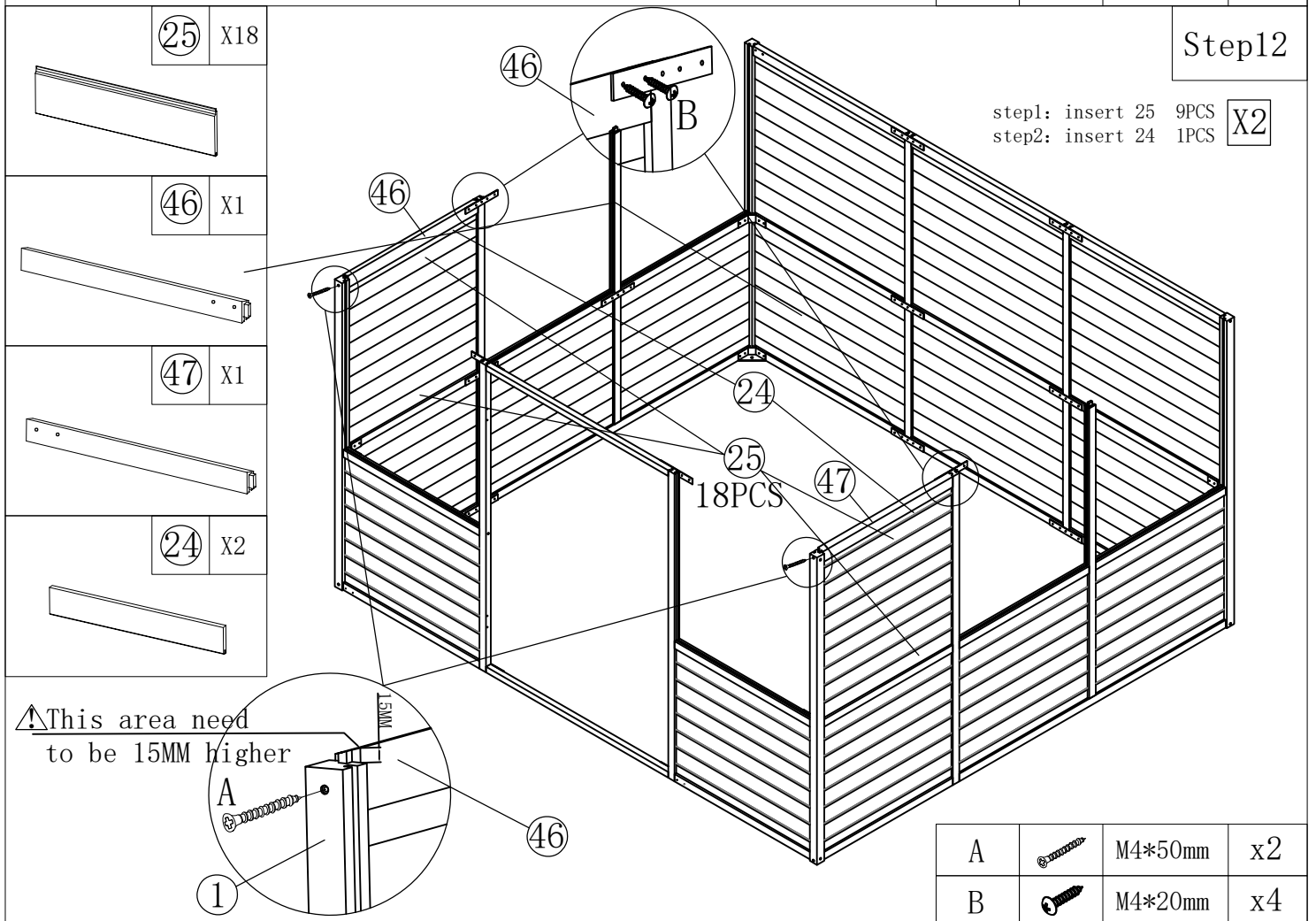
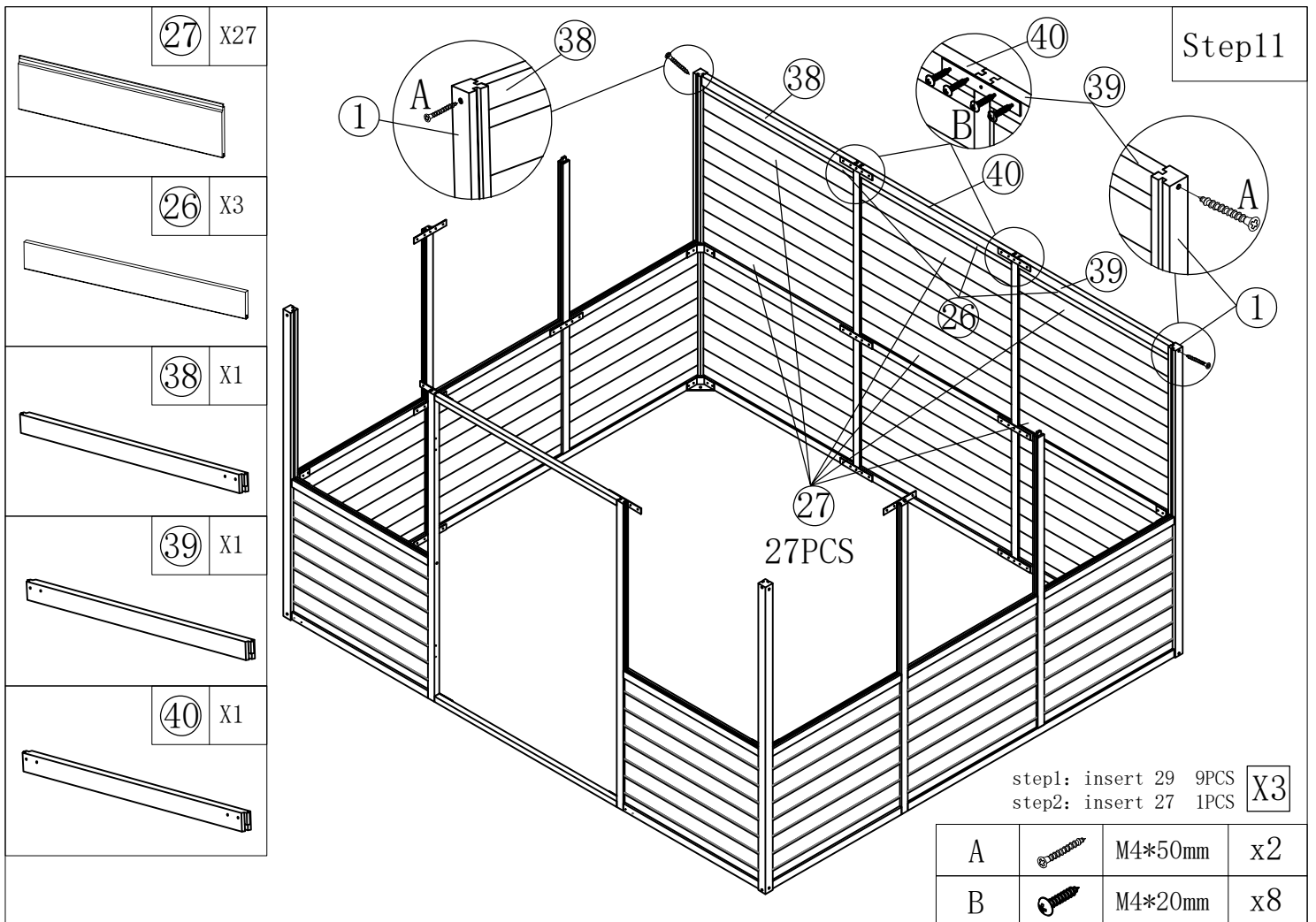

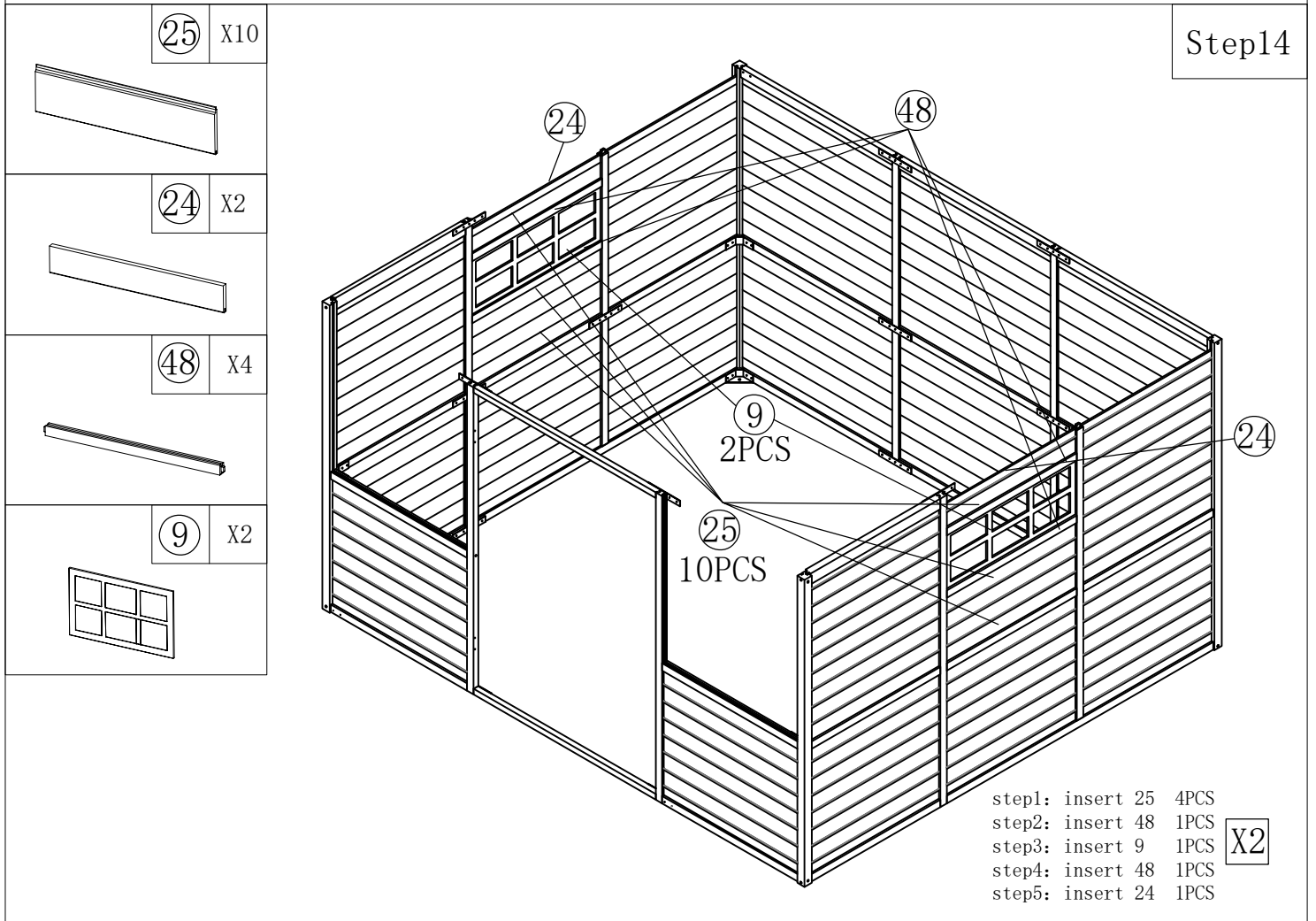
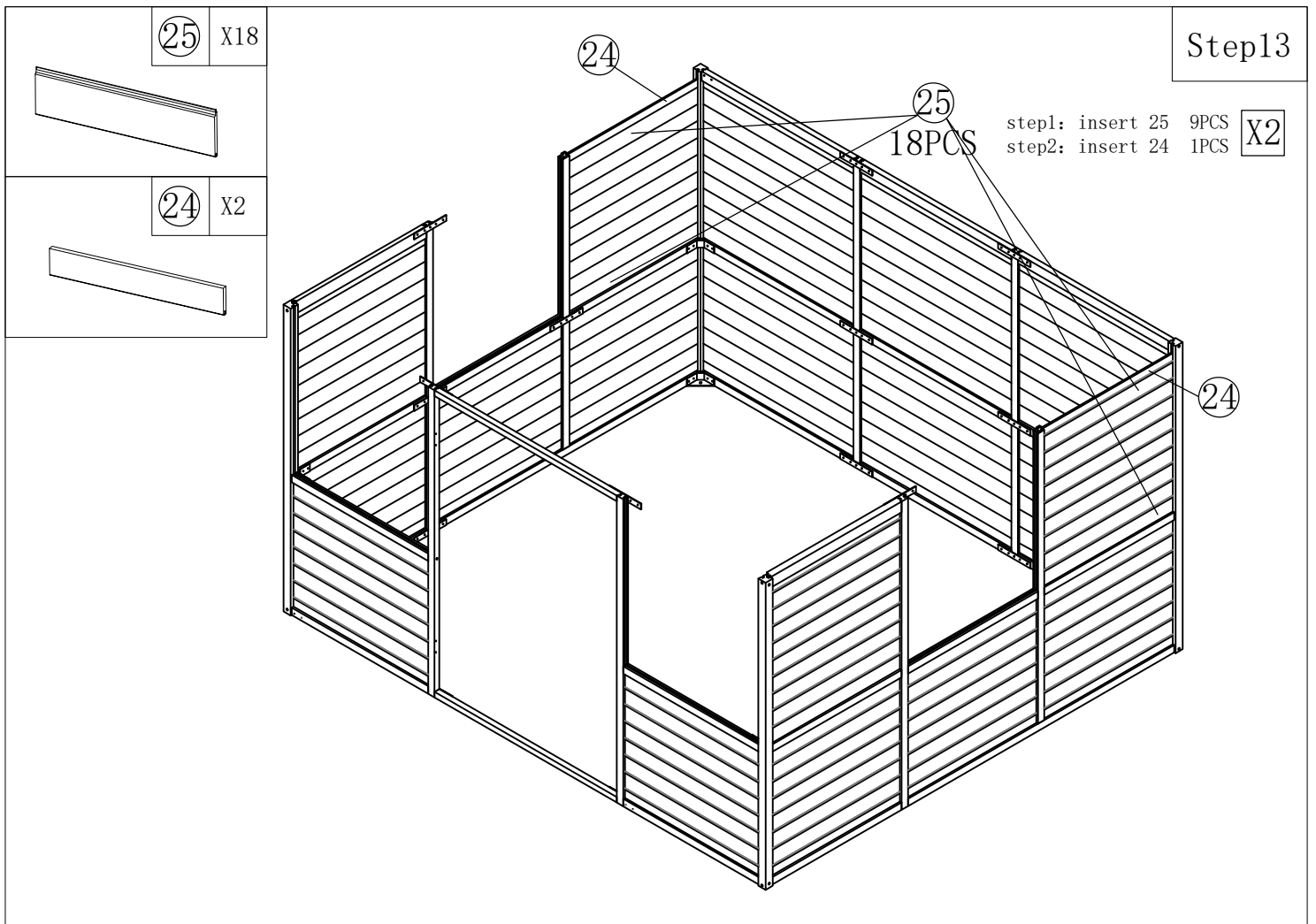
B		M4*20mm	x8
F		/	x2

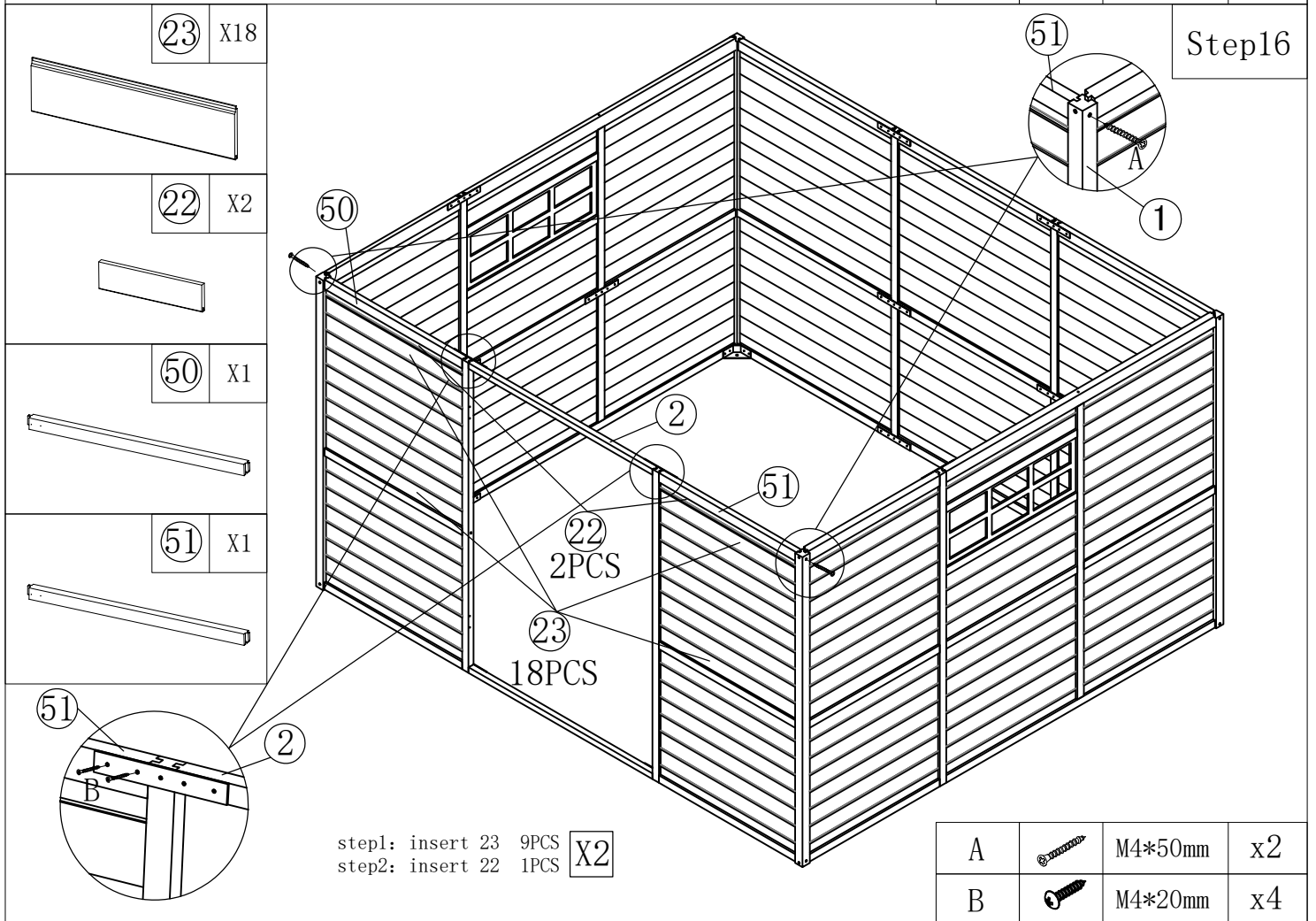
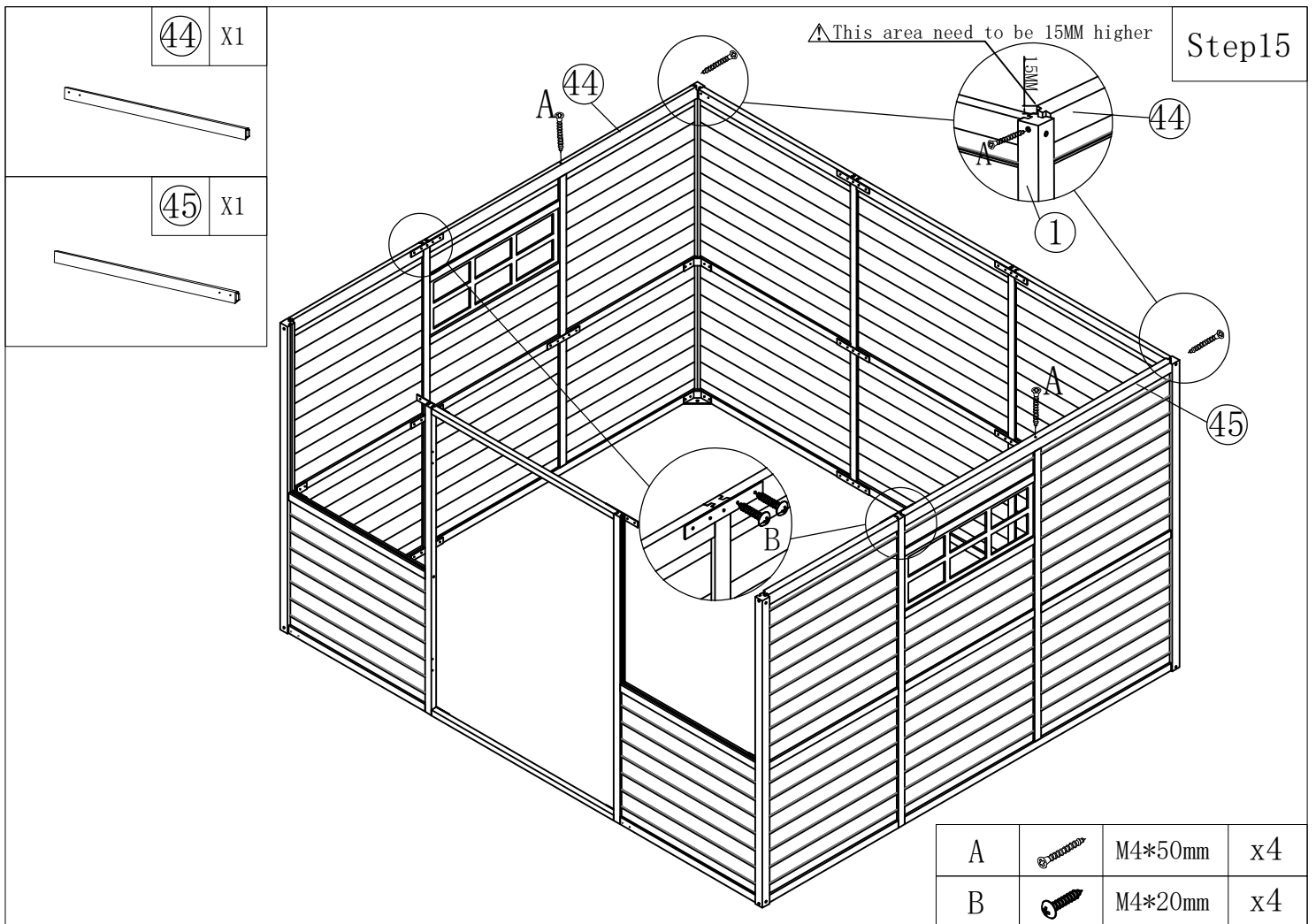

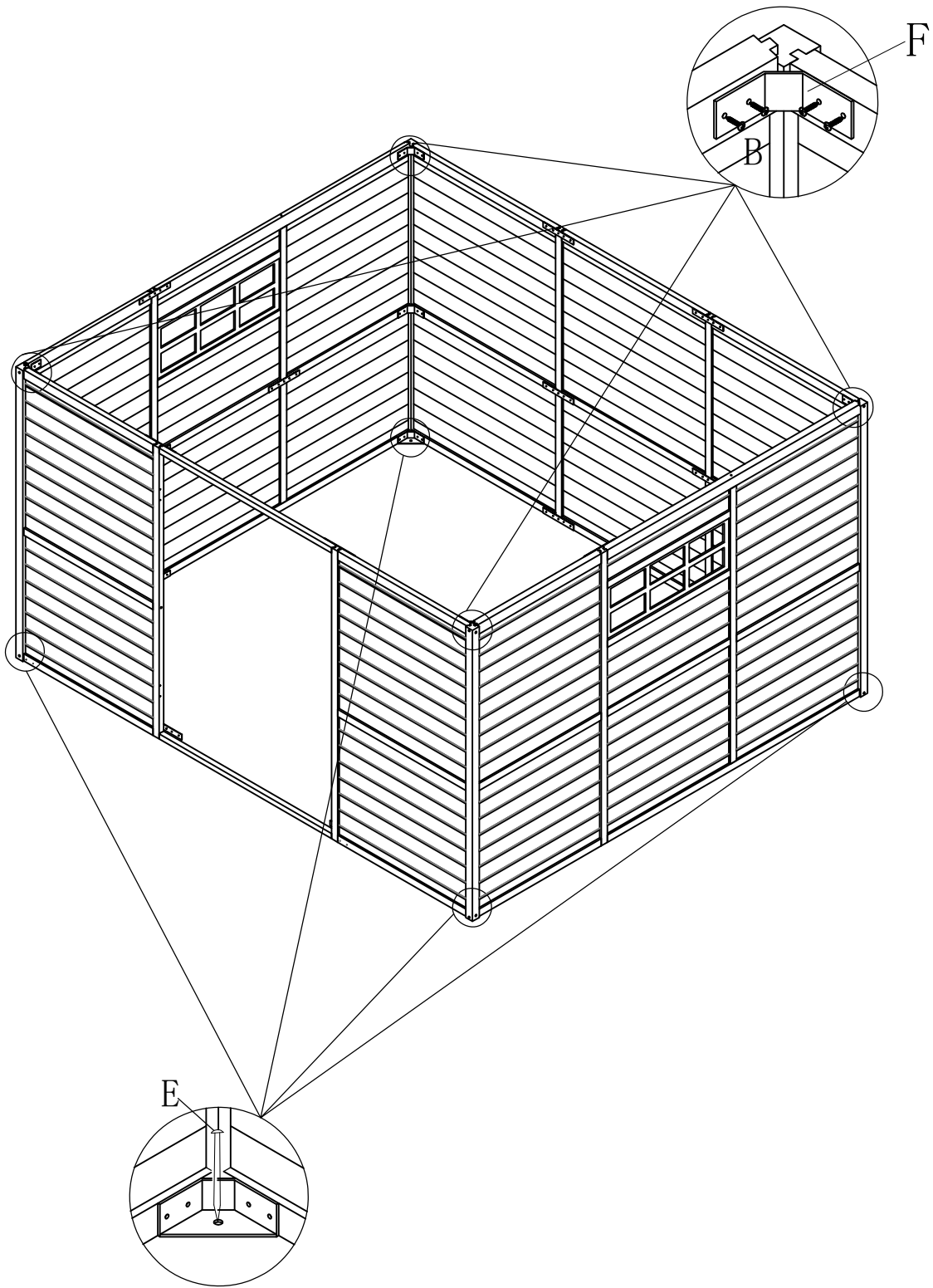





E		/	x4
B		M4*20mm	x16
F		/	x4

Step18

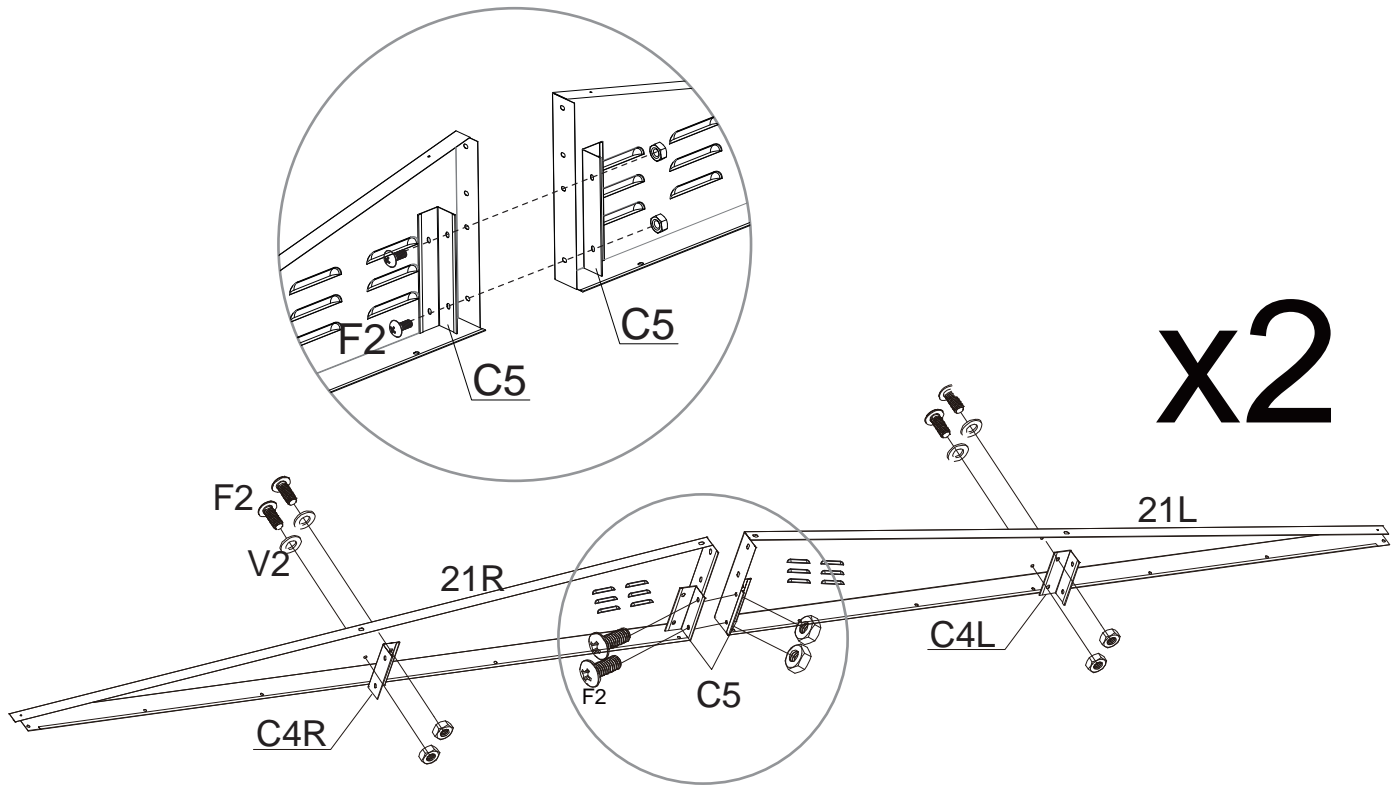

Step19

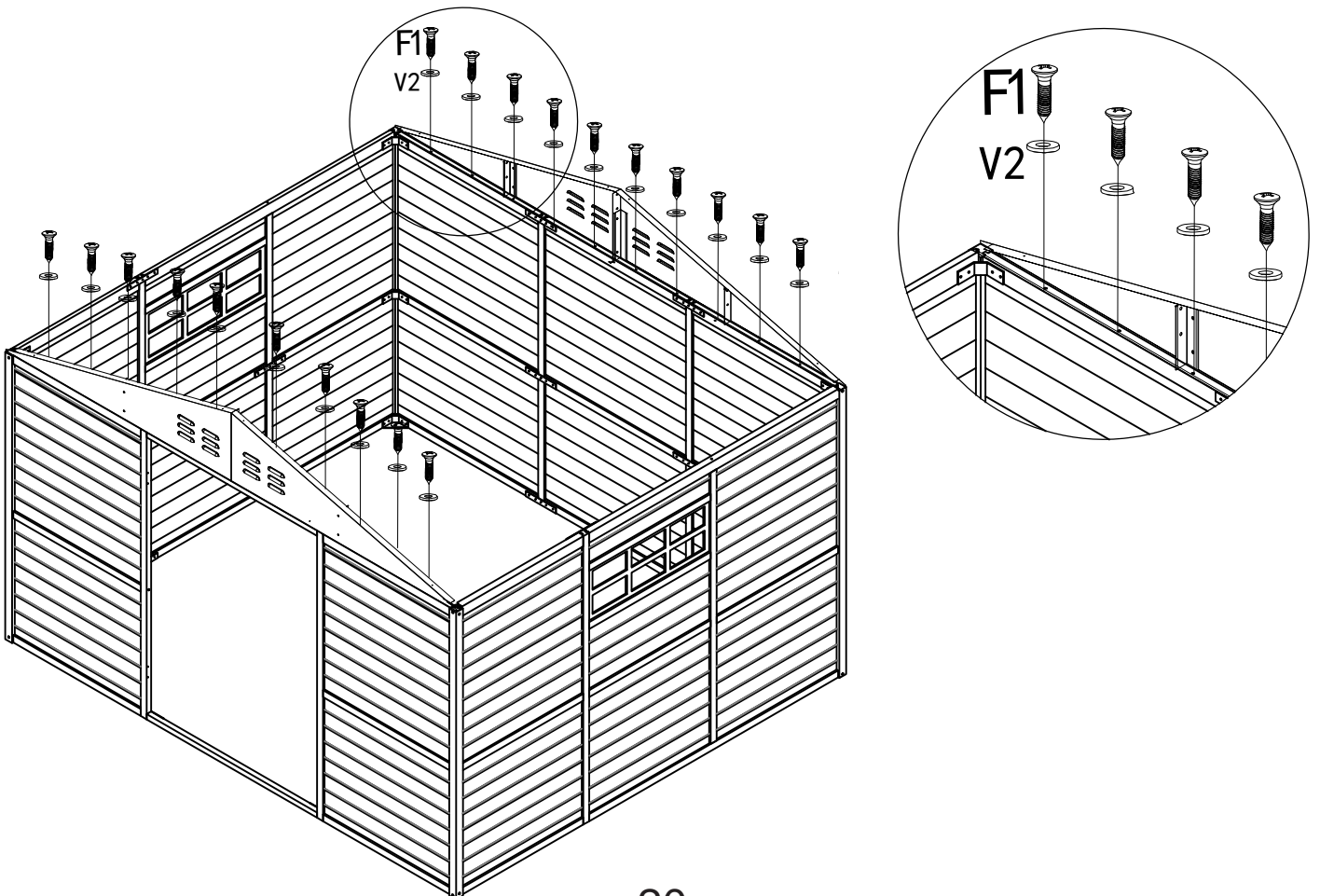

Step20

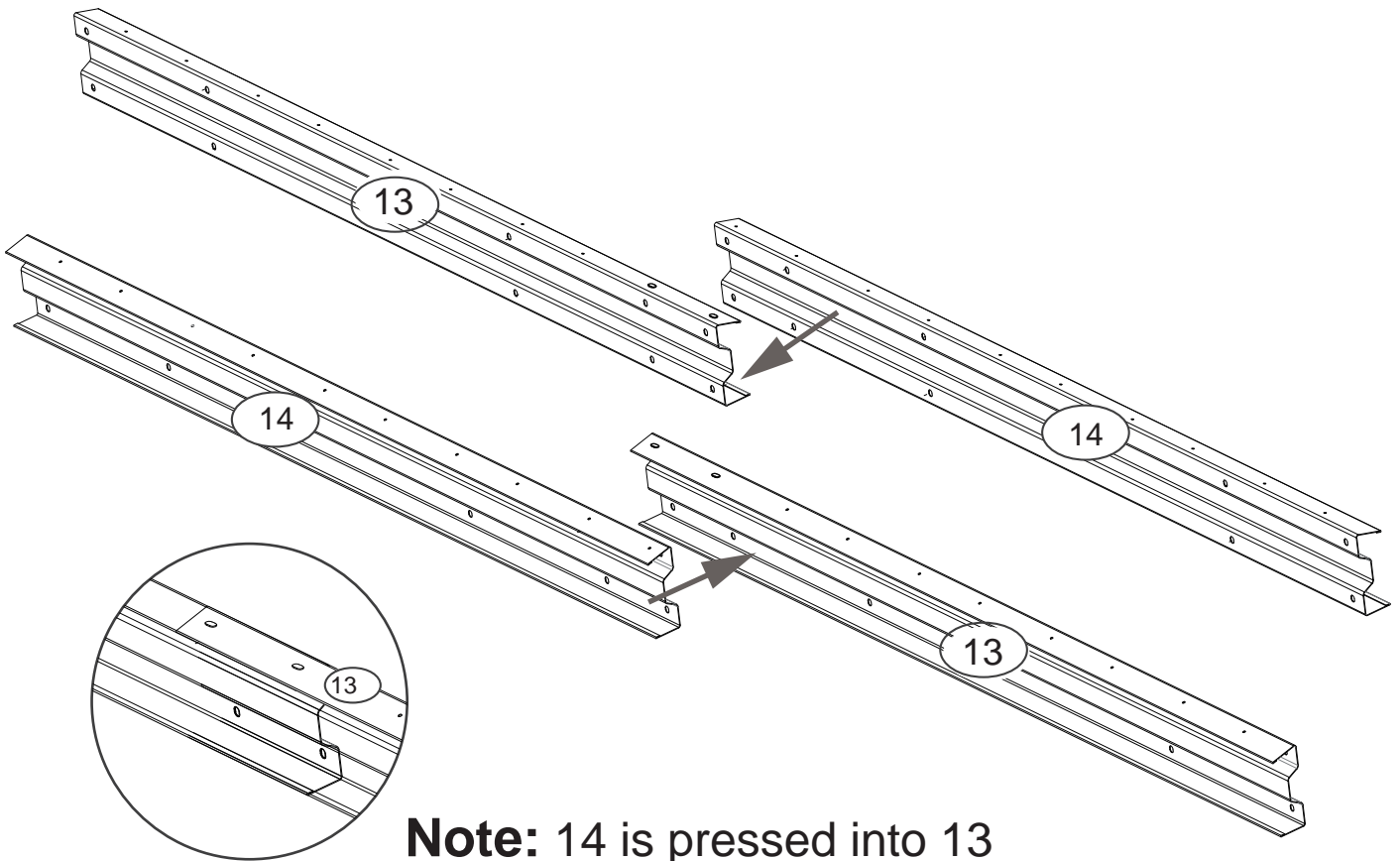

Note: 14 is pressed into 13

Step21

Don't tighten these two screws too tightly.

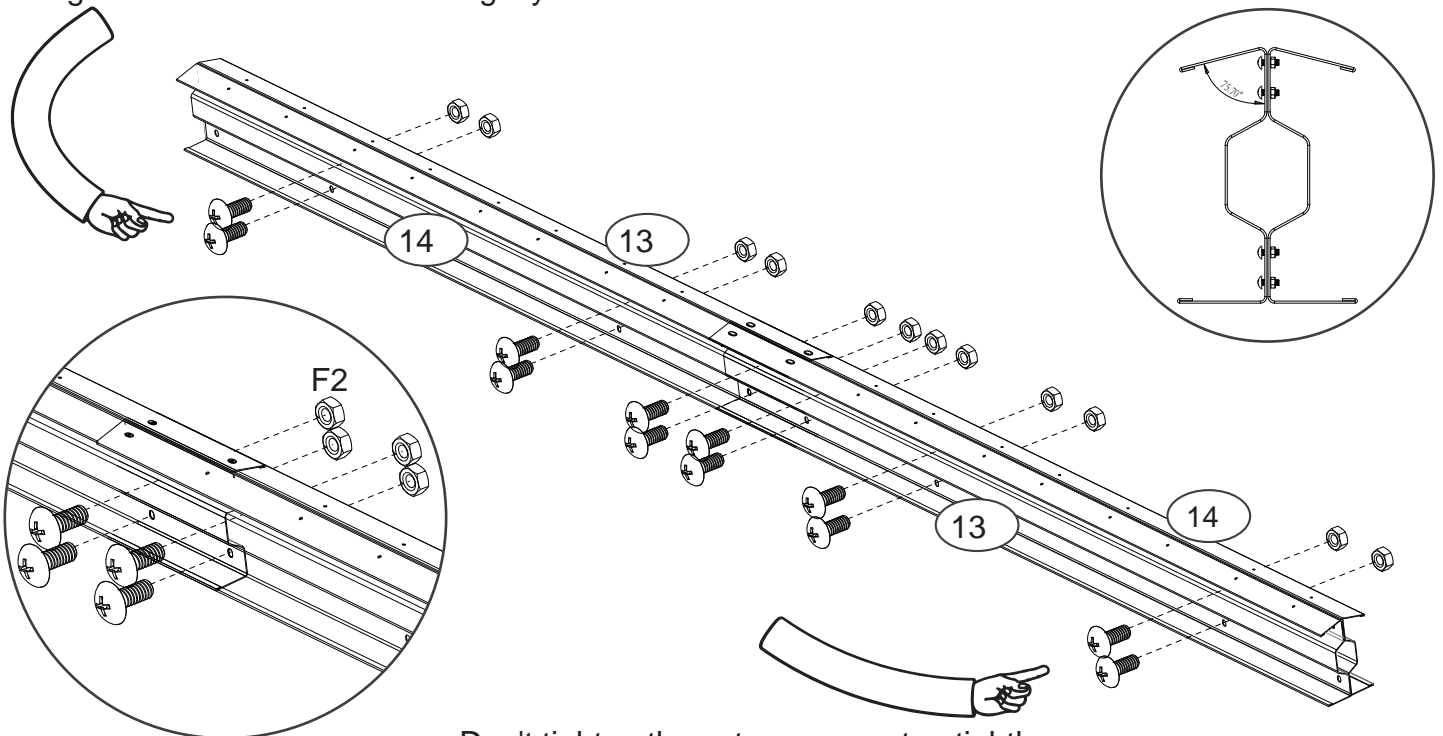

Don't tighten these two screws too tightly.

Step22

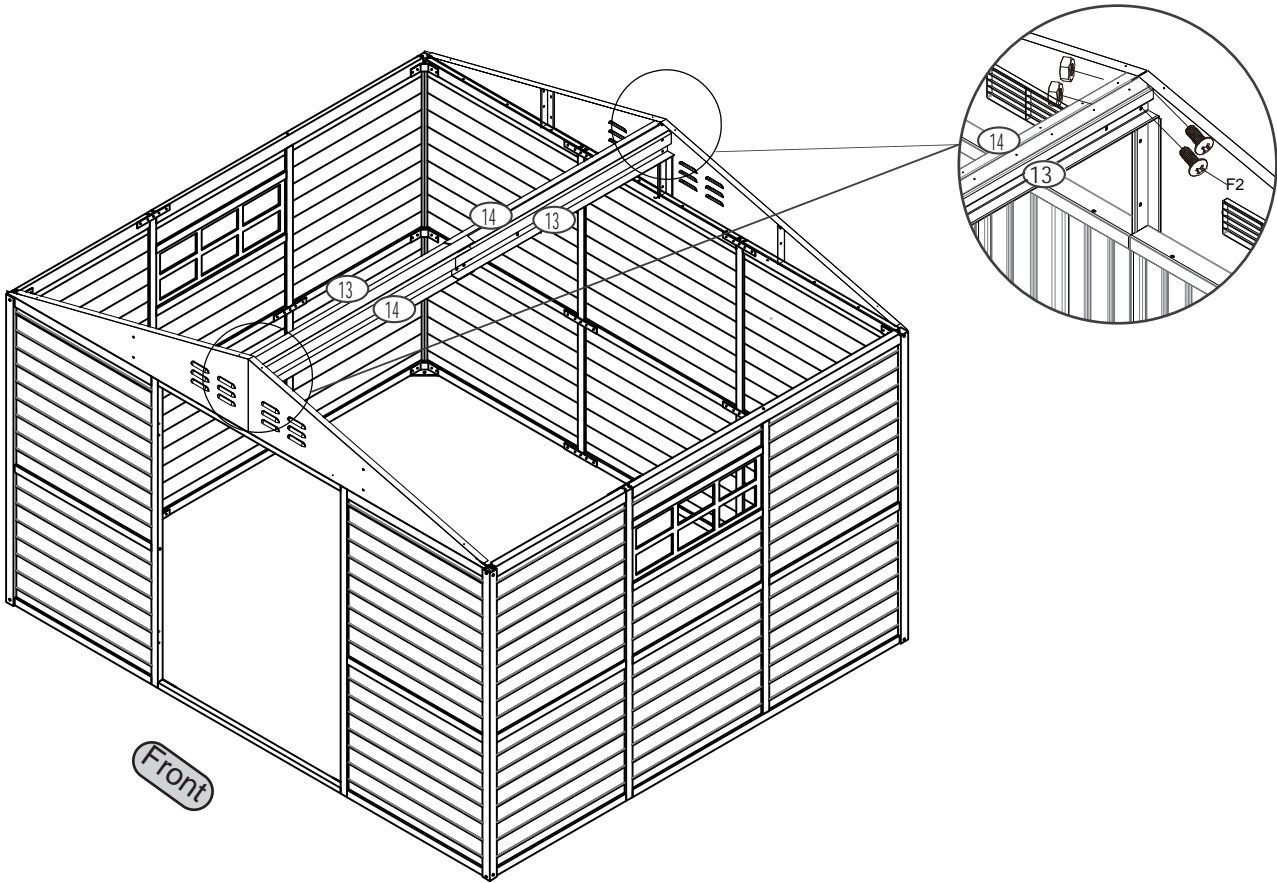

Step23

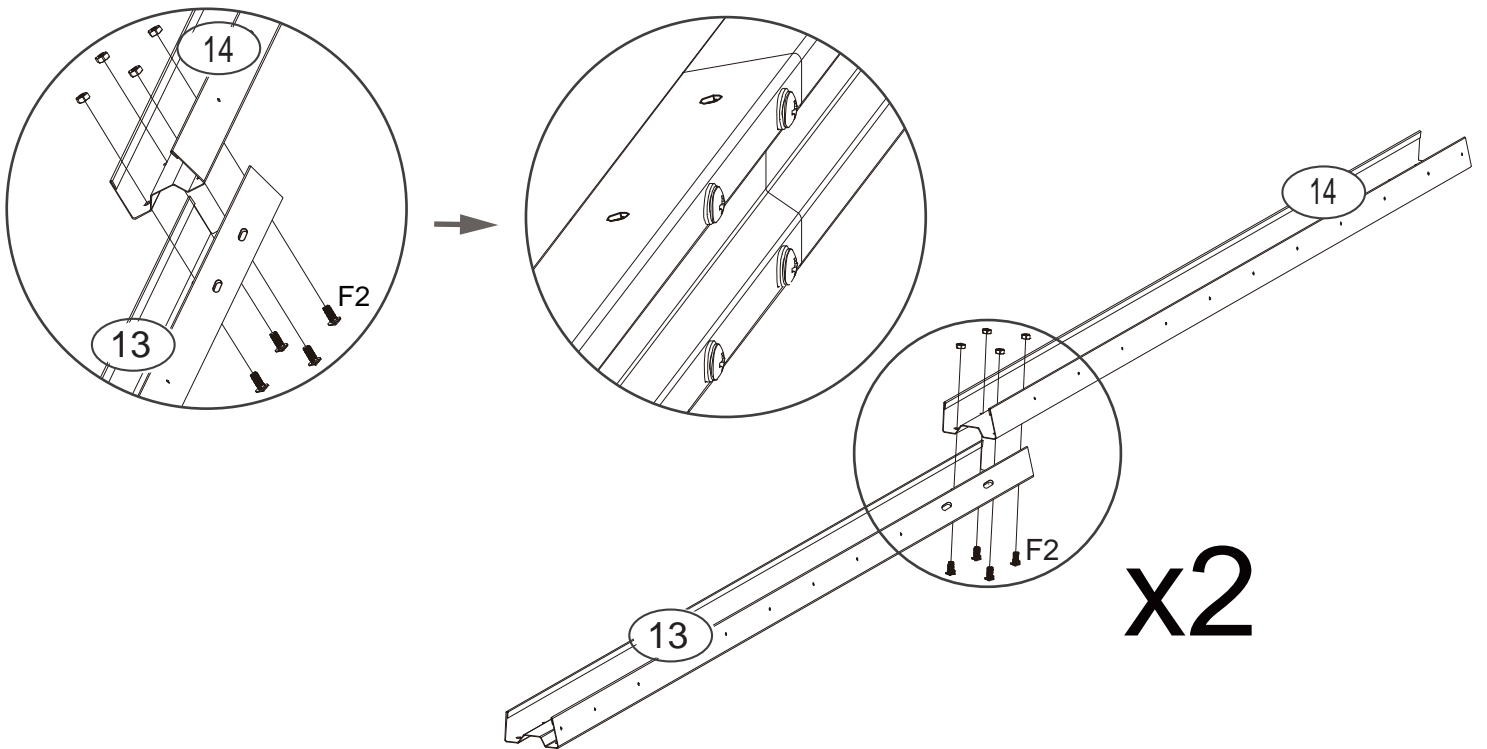

Step 24

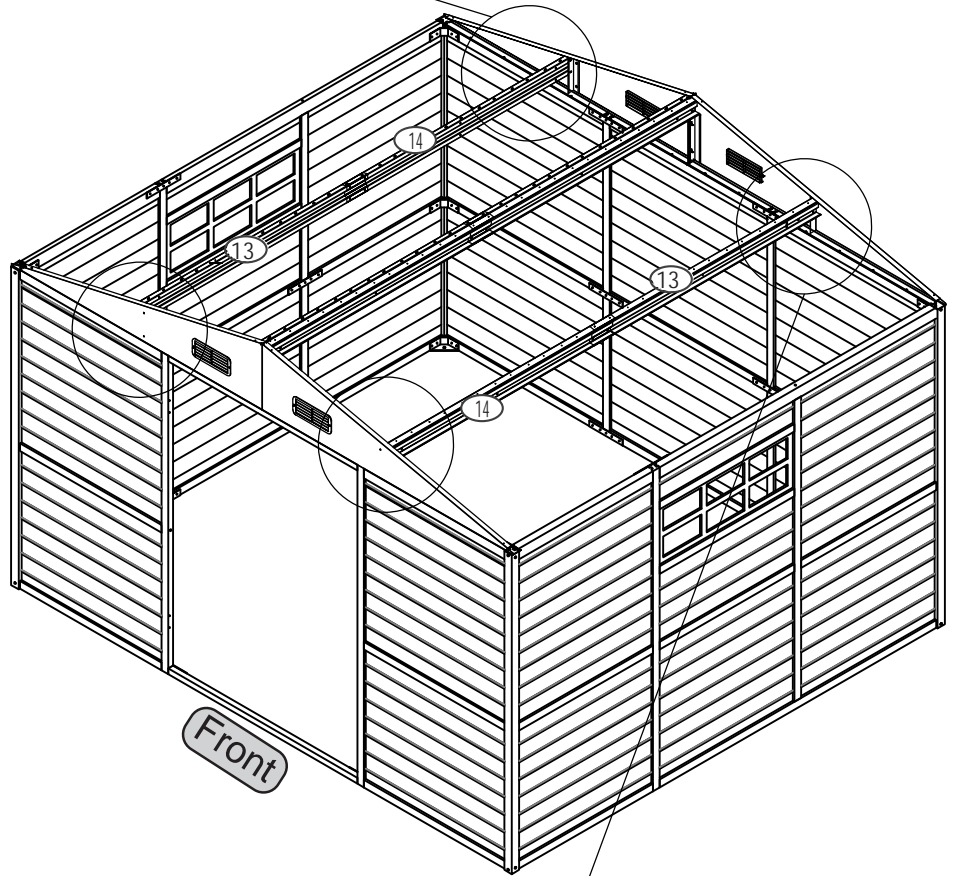
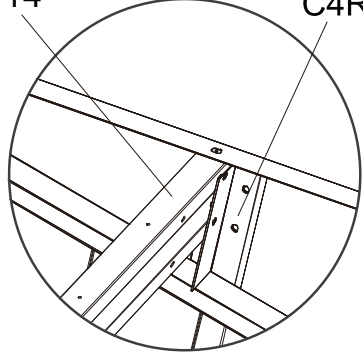
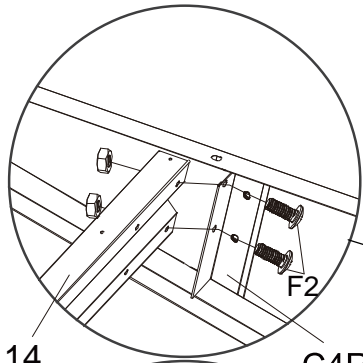

Tighten all screws.

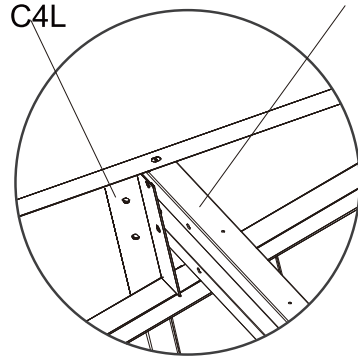
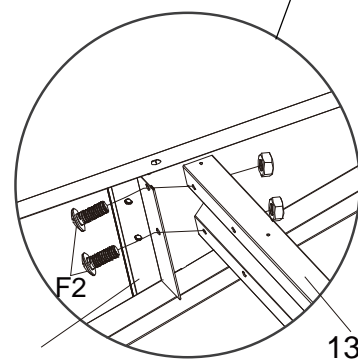

Step25

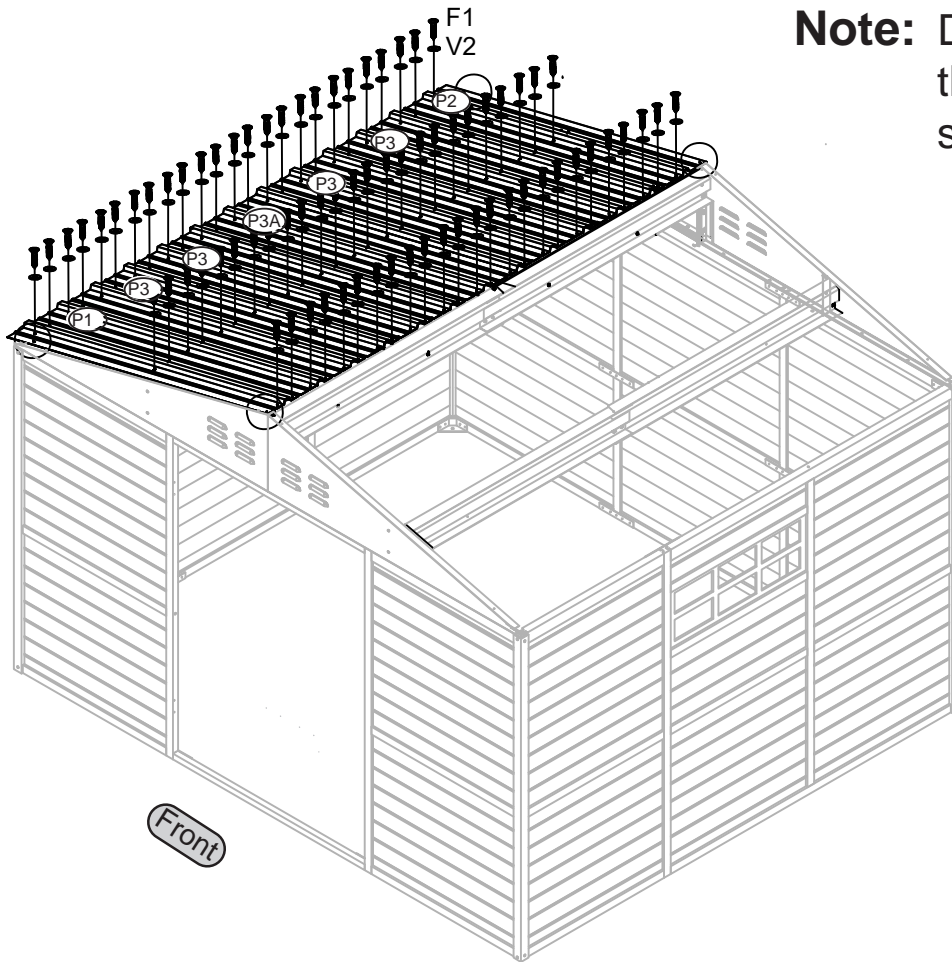

Note: Do not install F1 and V2 in the holes near the outer side of P1, P2

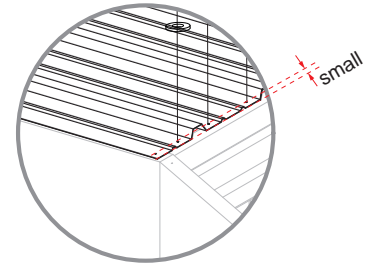

Short distance from the edge at the top.

Step26

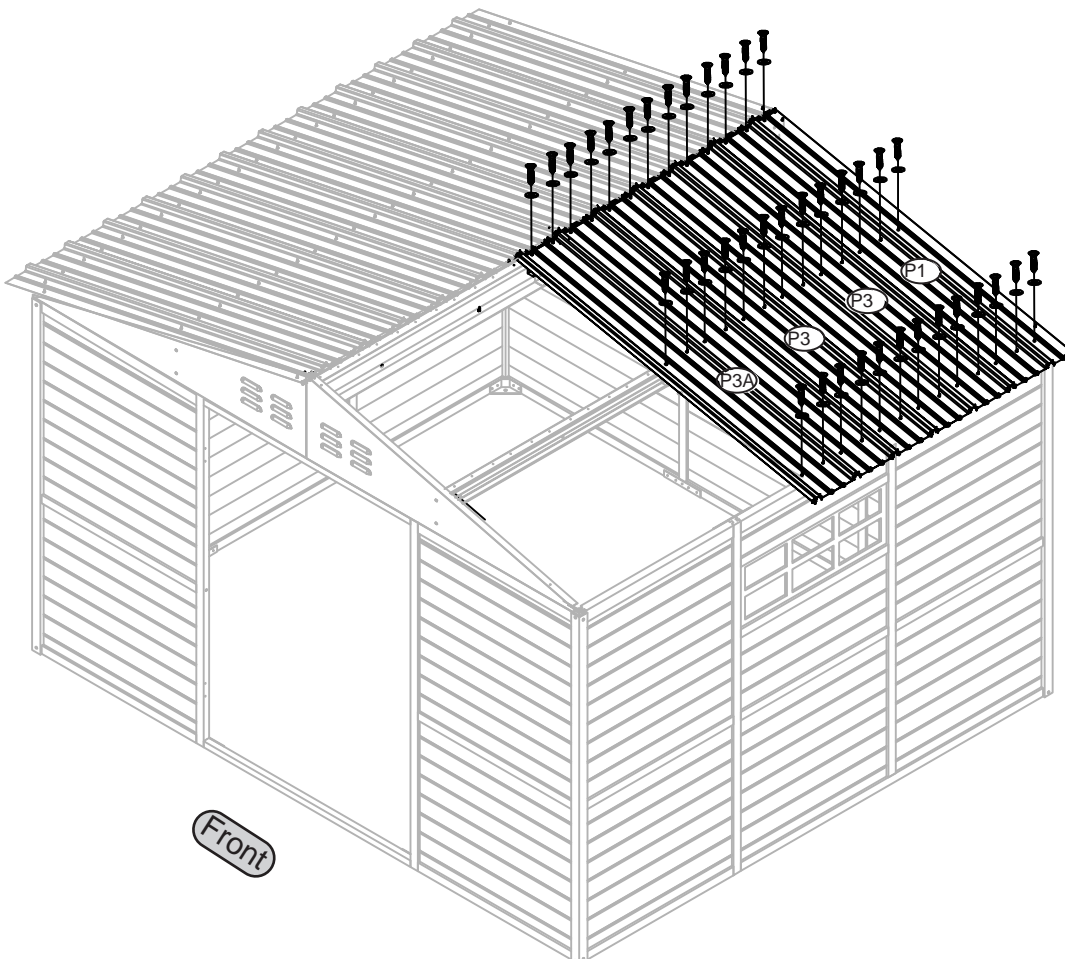

Step27

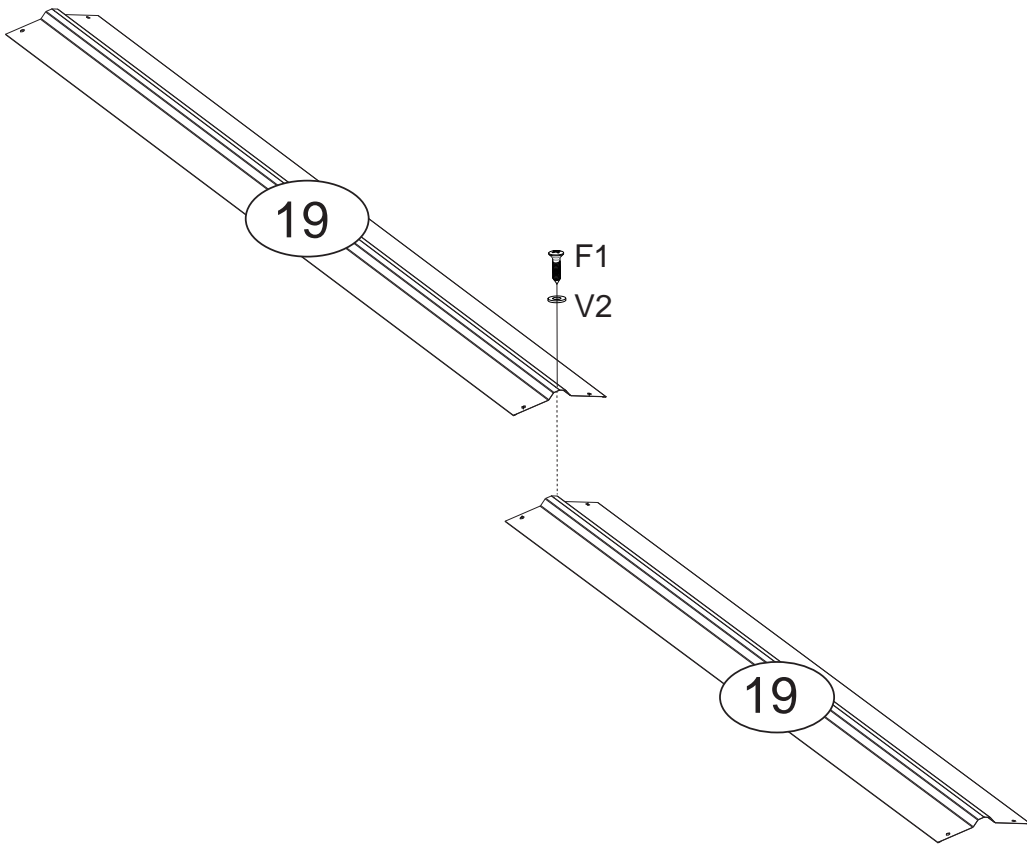

Step28

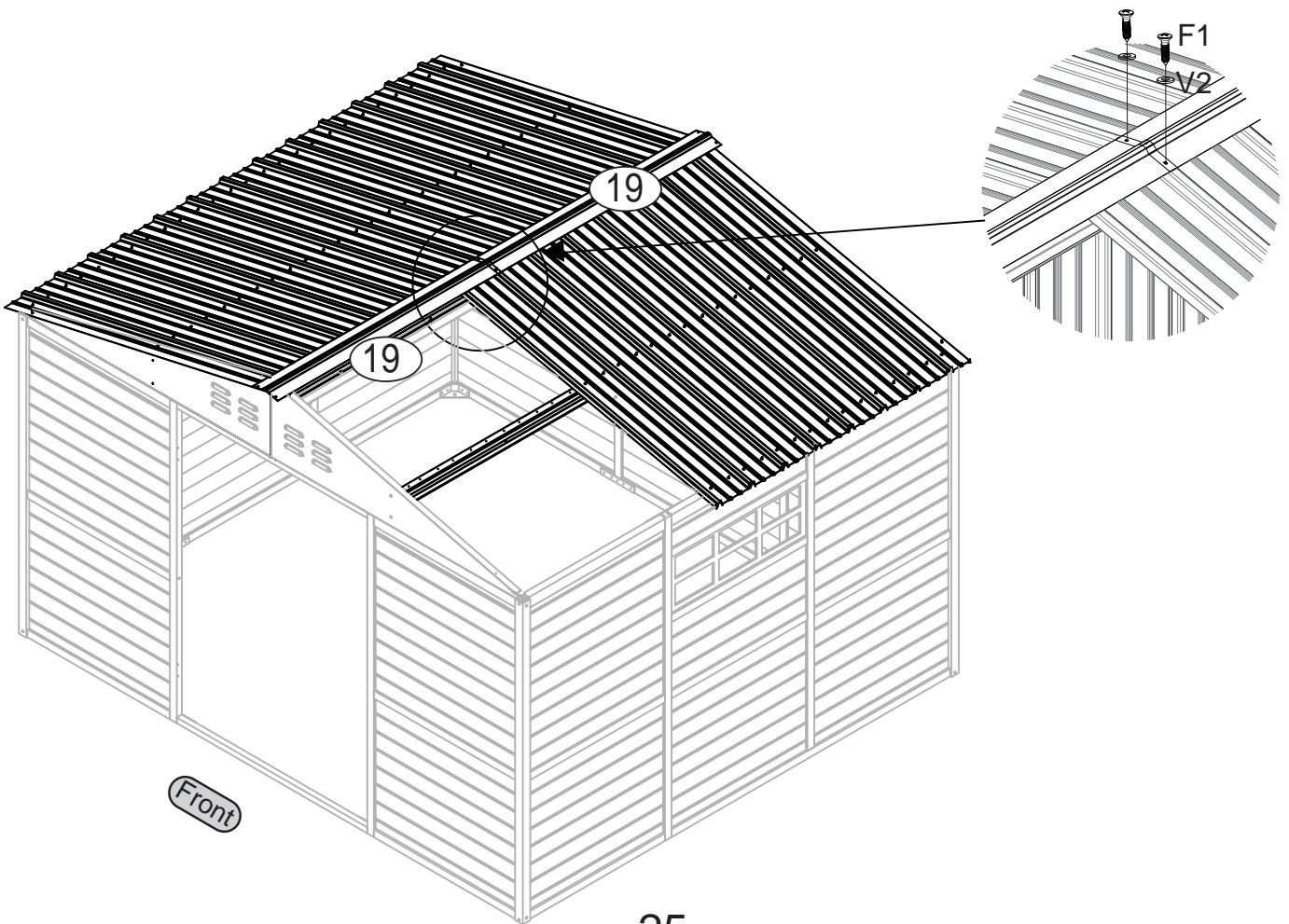

Step29

Installation tips: You need to gently lift the 19 and then screw it.

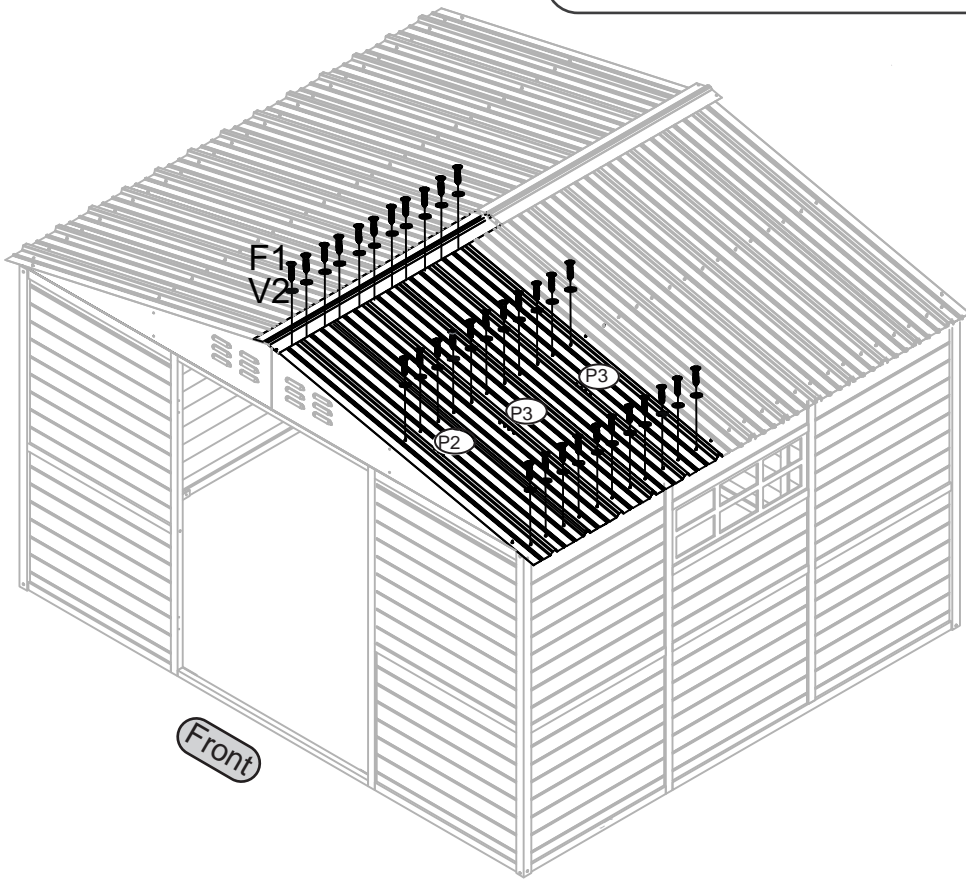

Step30

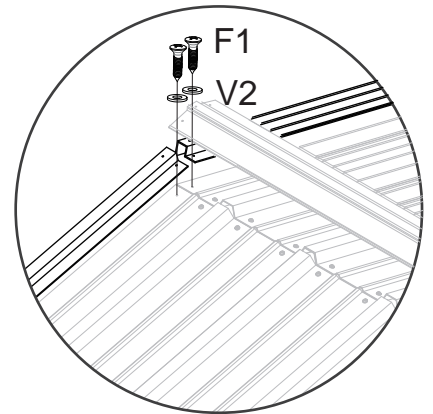
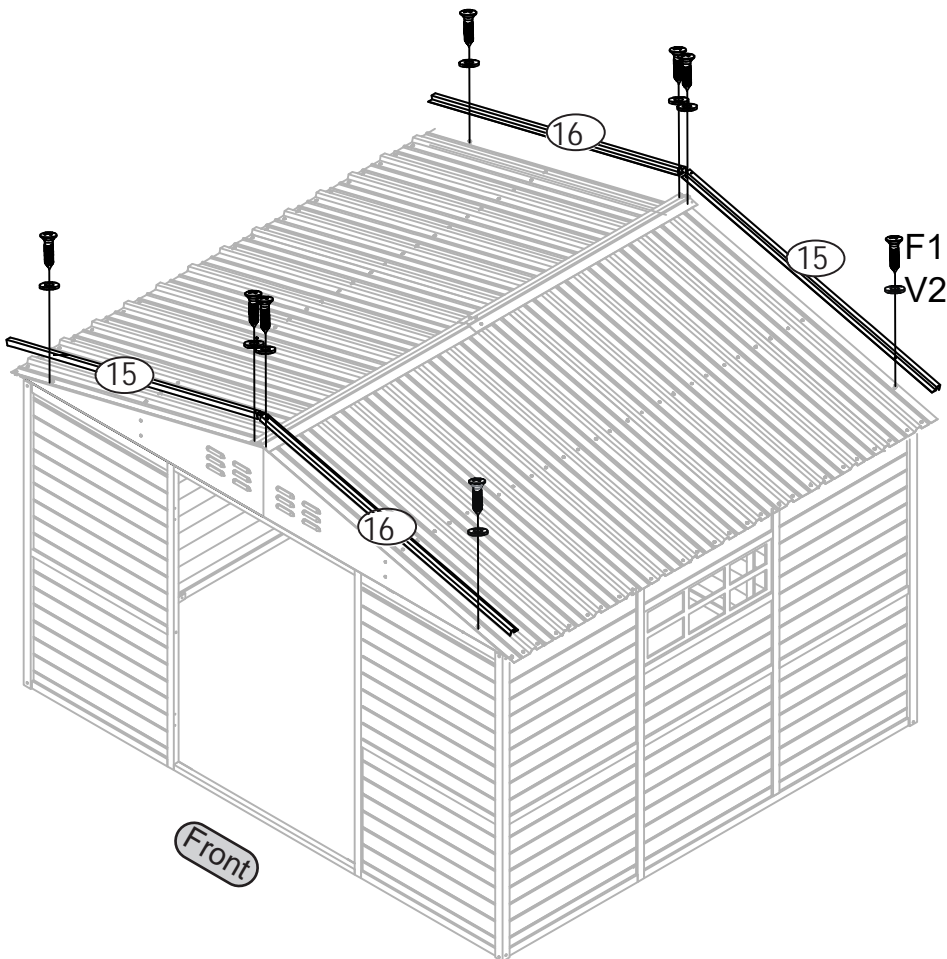

Step31

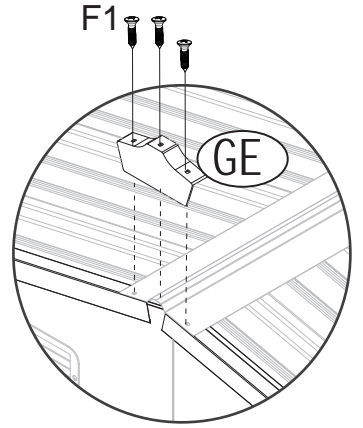
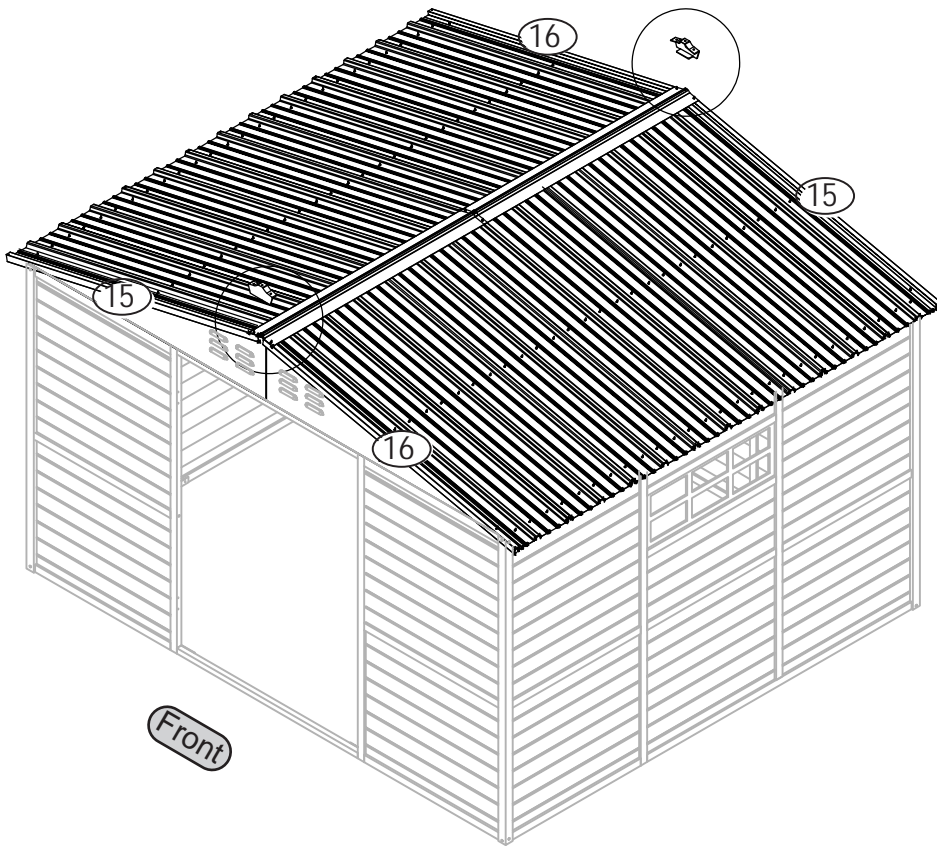

x2

Step32

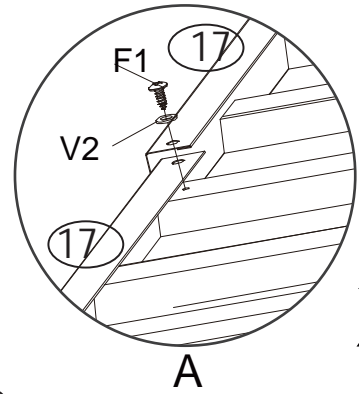
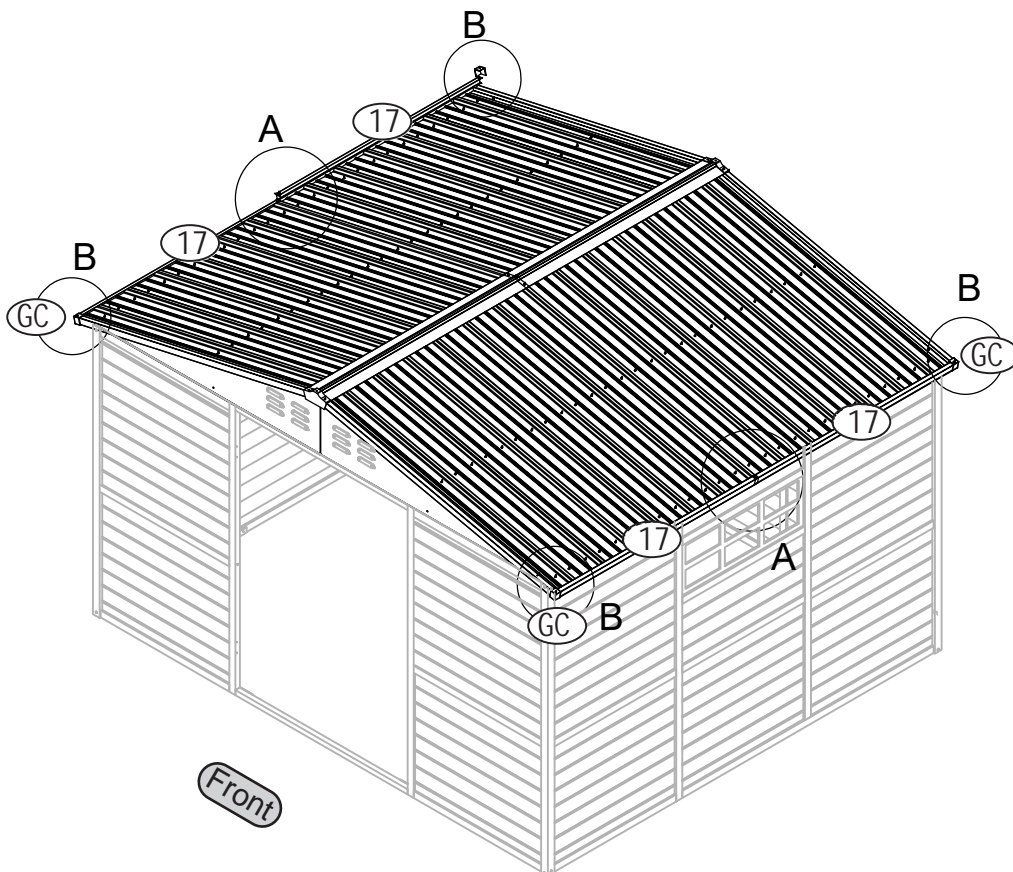

x2

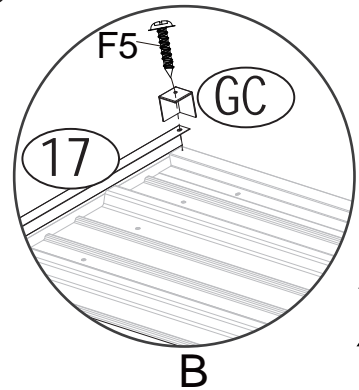

x4

Step33

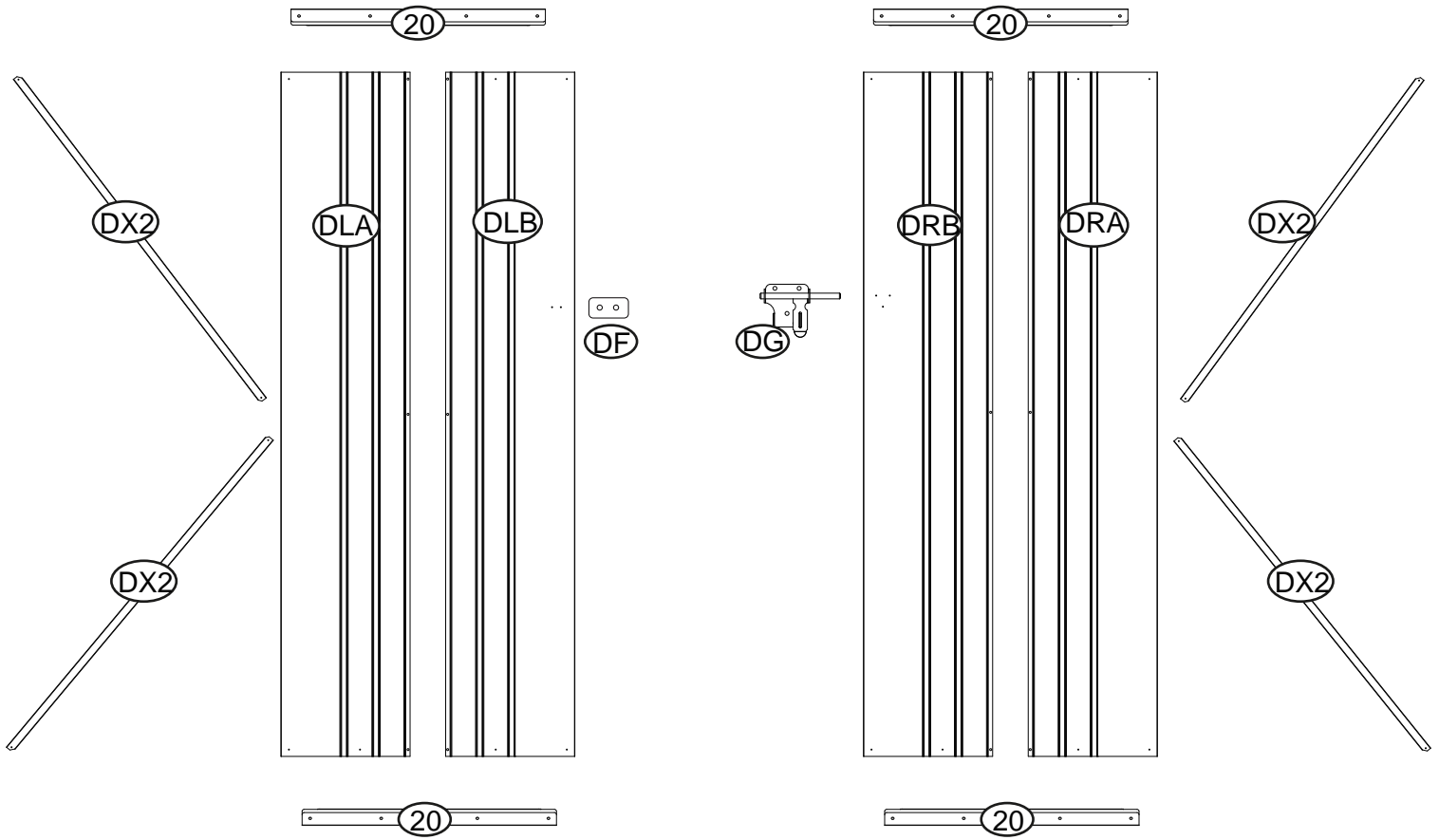

Step34

The other door operates the same way

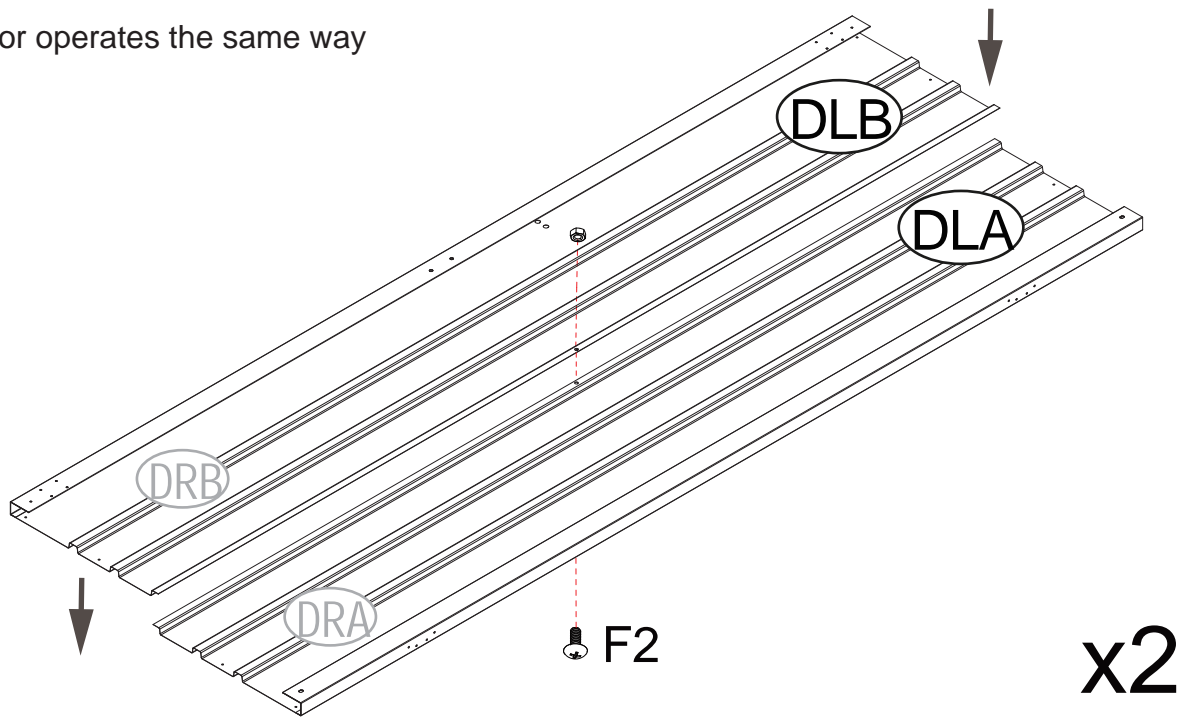

Step35

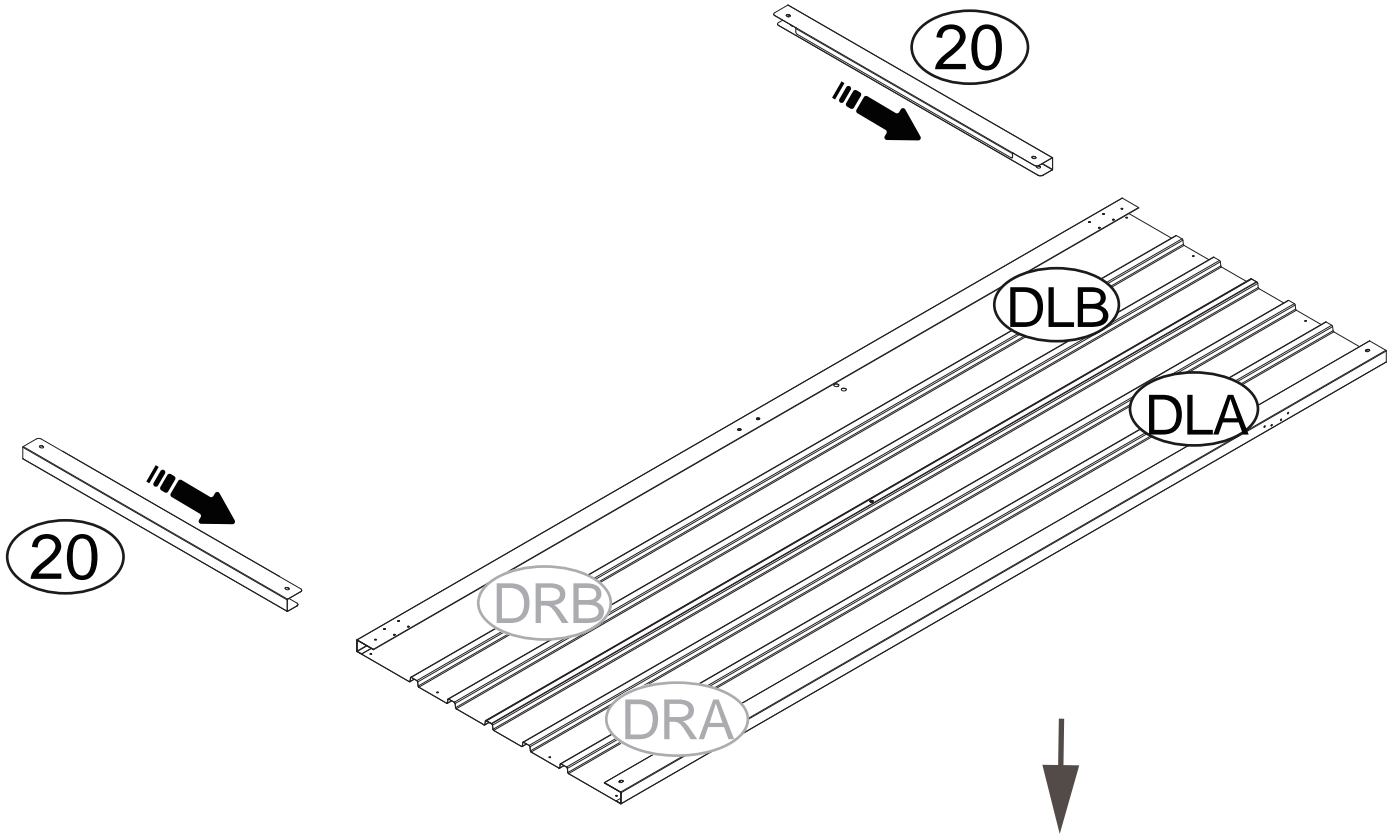

Step36

The other door operates the same way

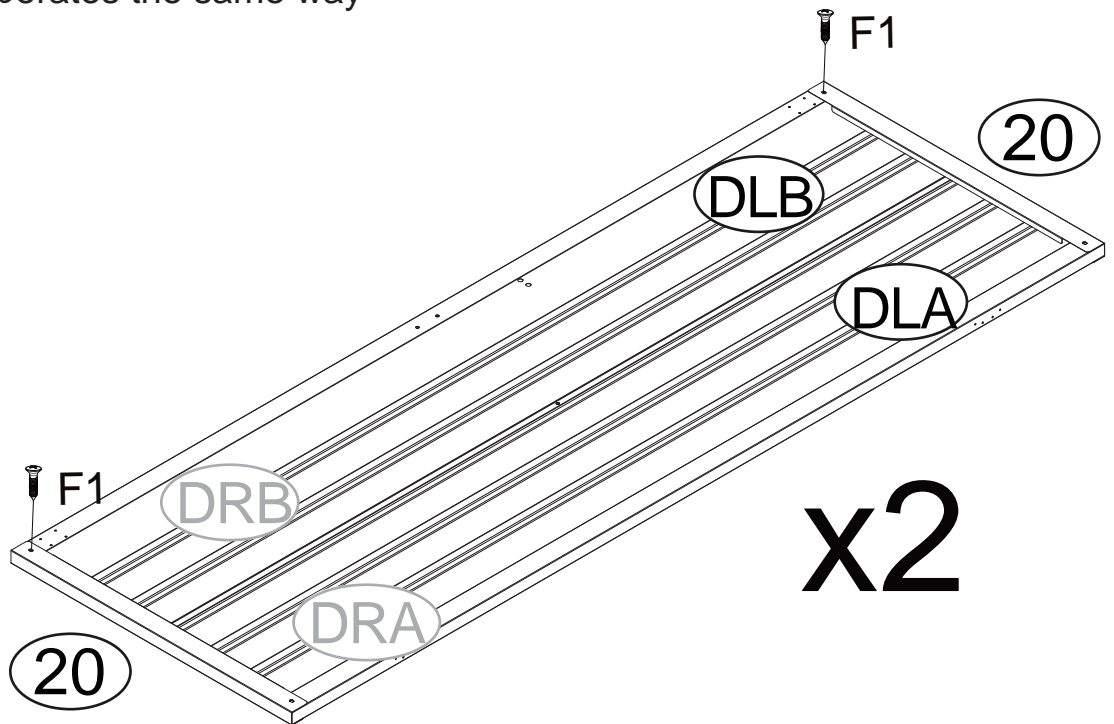

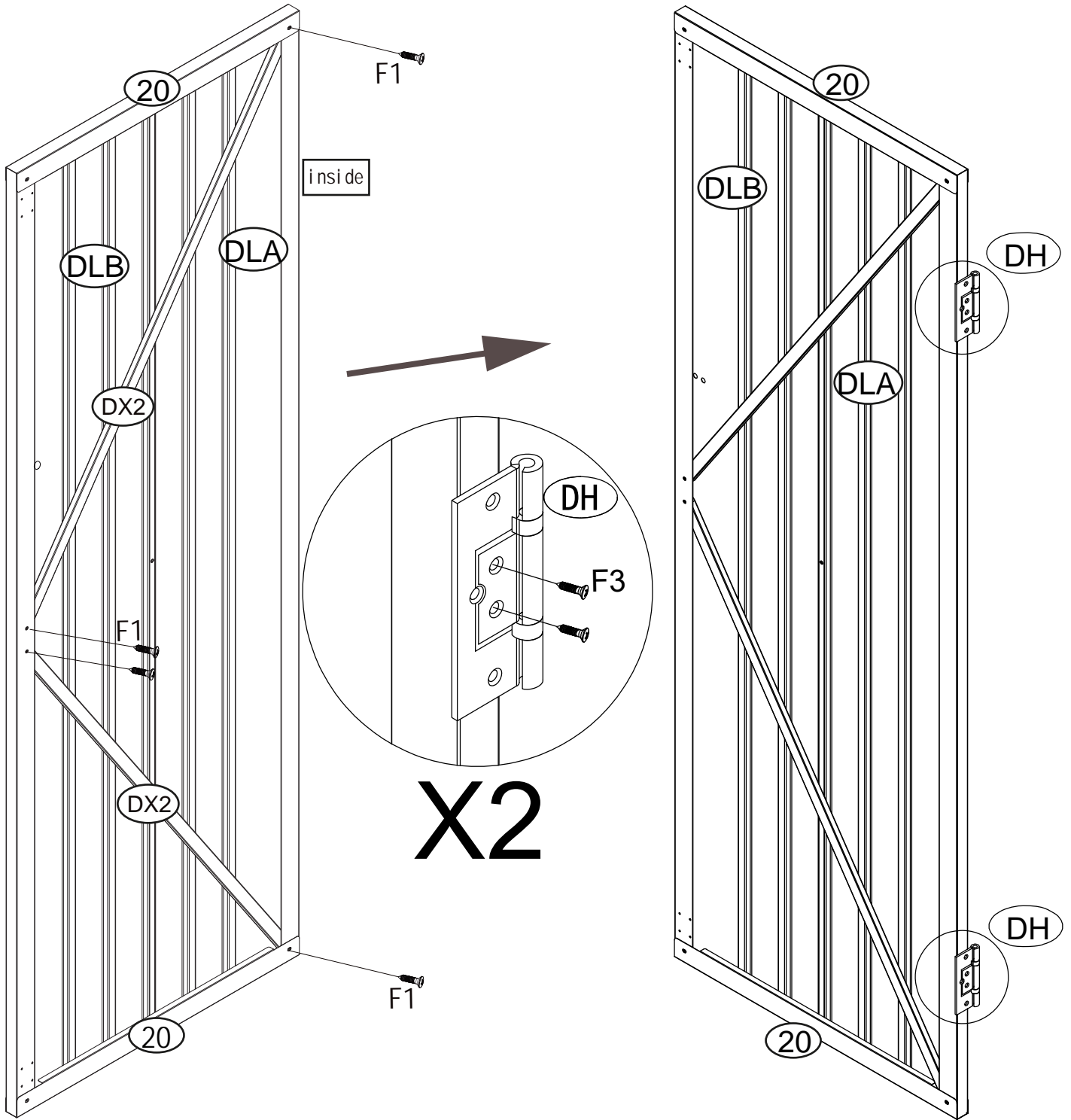

Step38

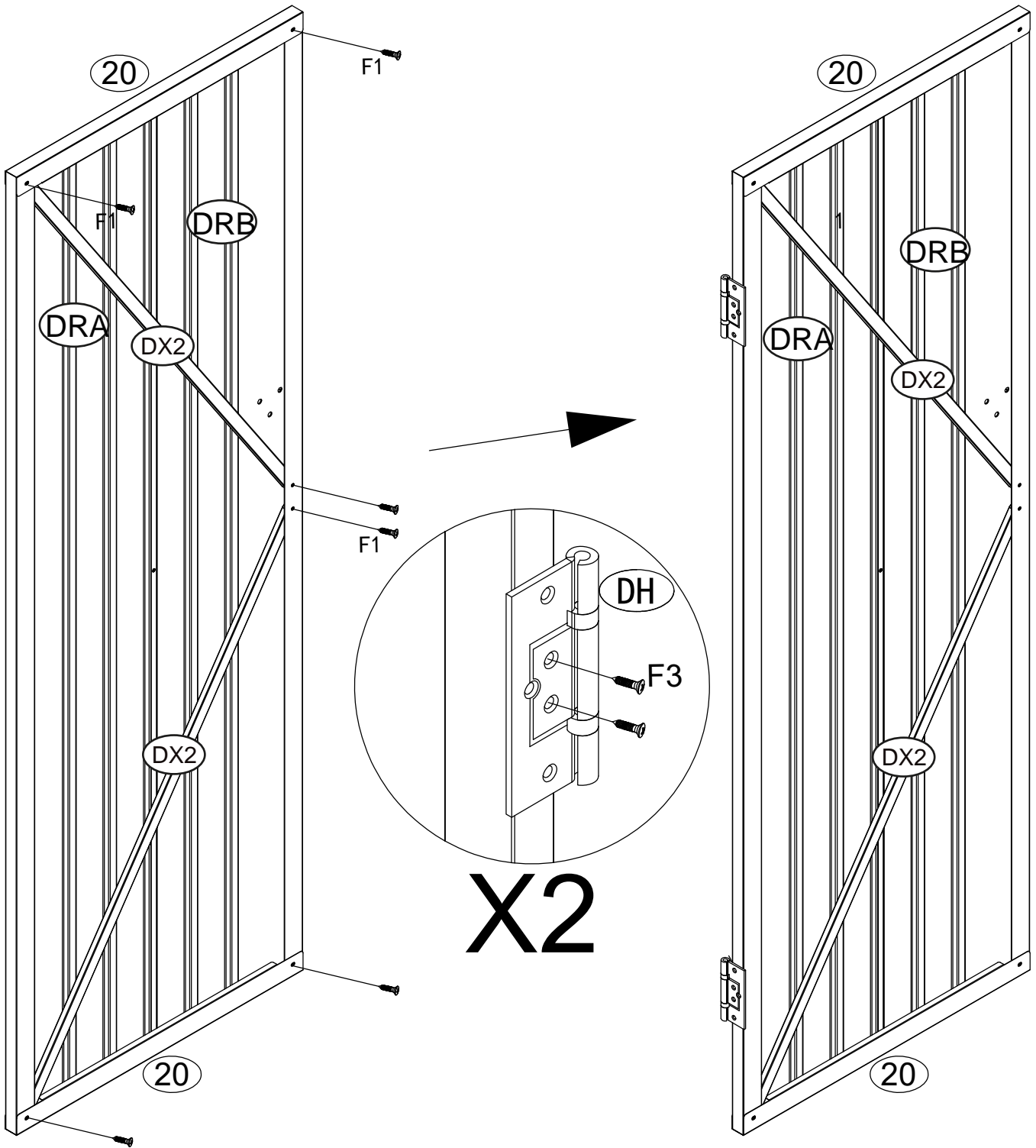

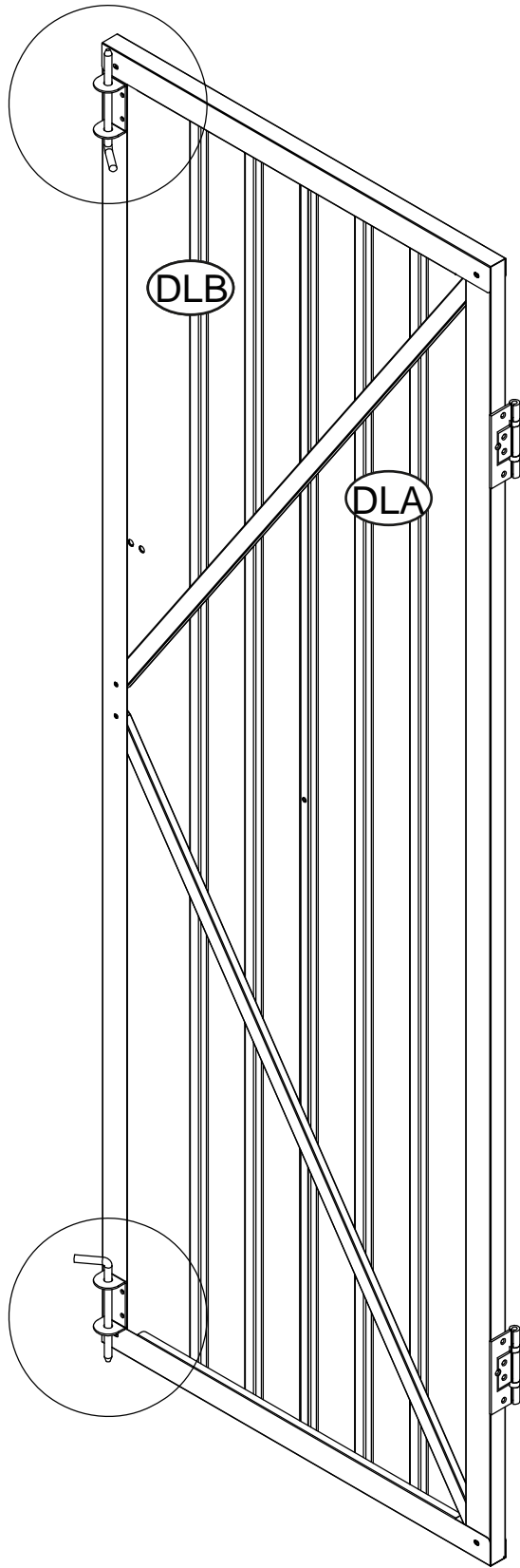
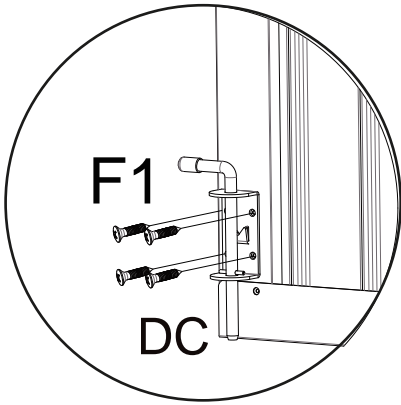
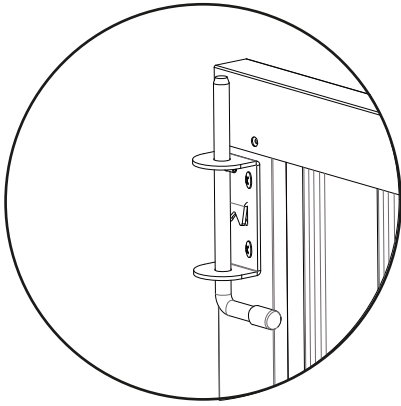
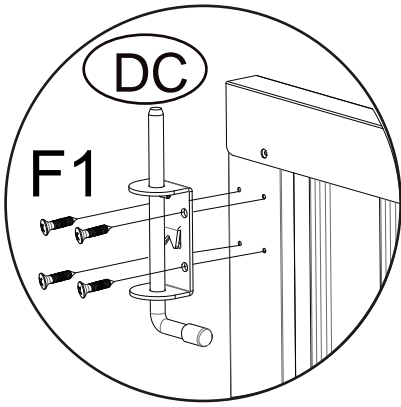

Step40

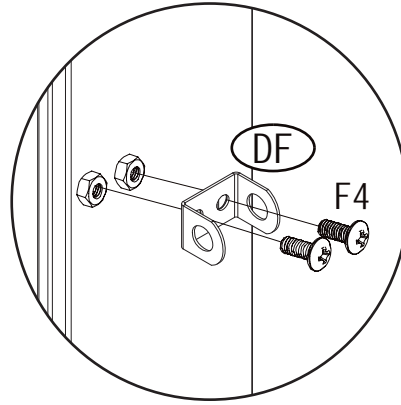
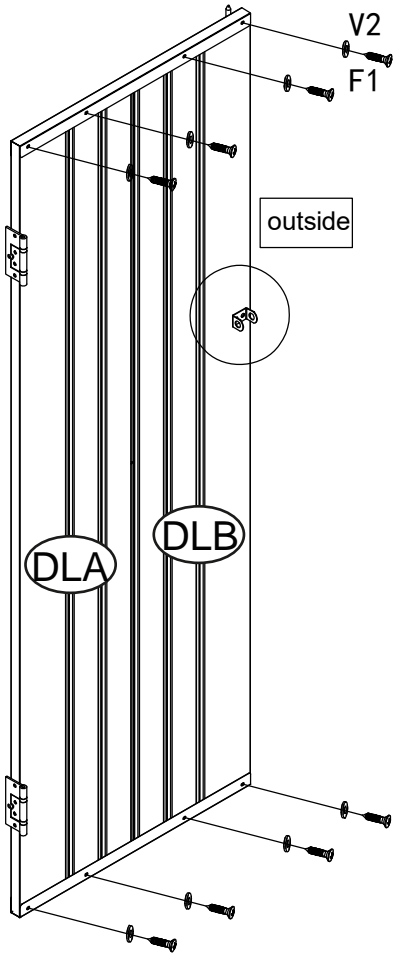

Step41

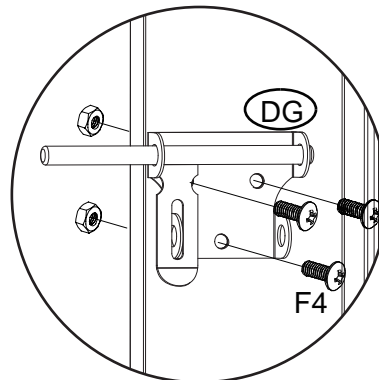
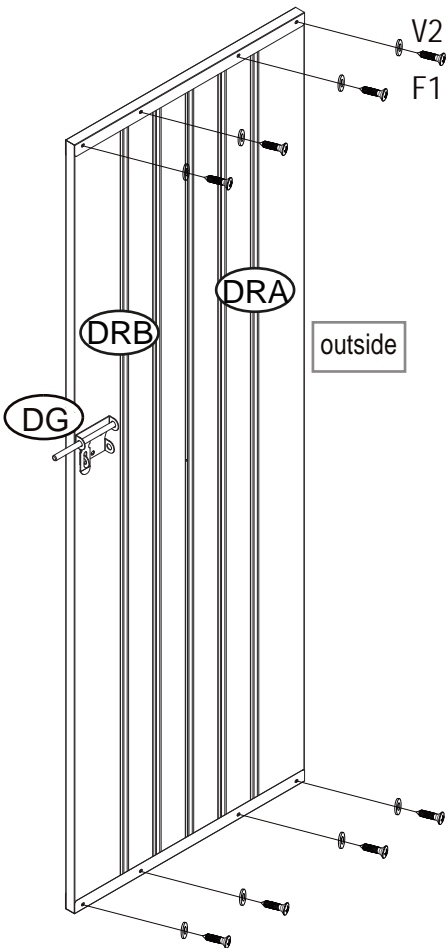

Step42

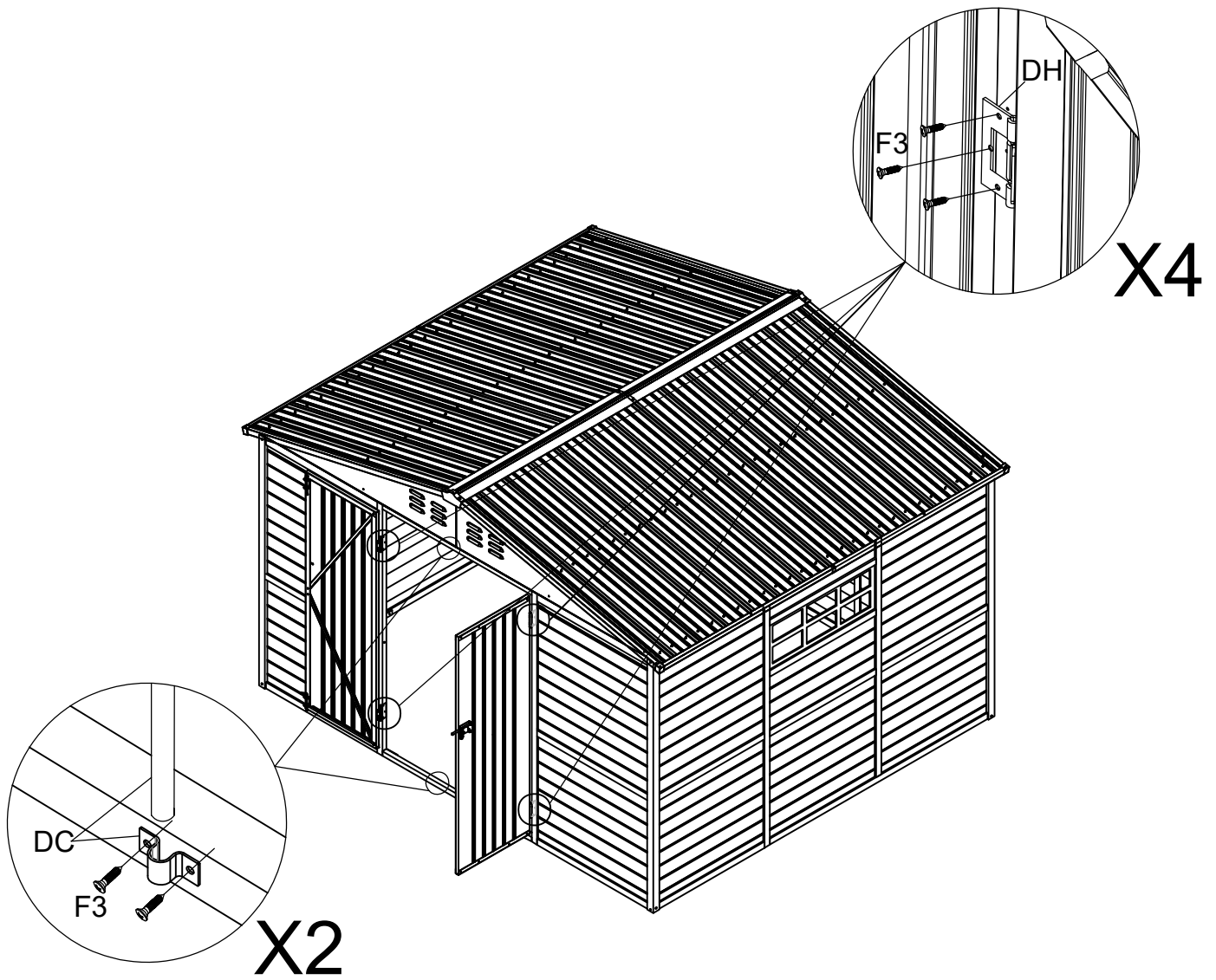

Step43

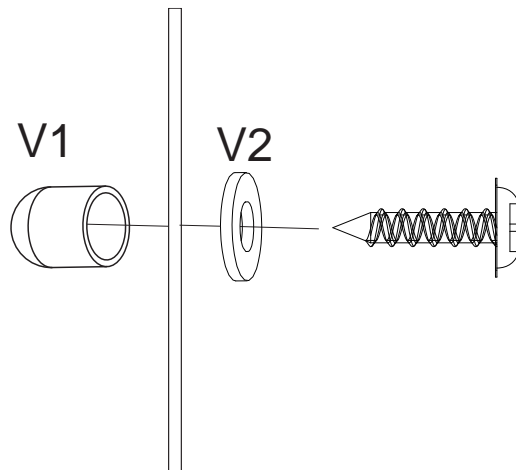

Put it on the screw tip to prevent injury.