

ASSEMBLY INSTRUCTION

INSTRUCTIONS DE MONTAGE

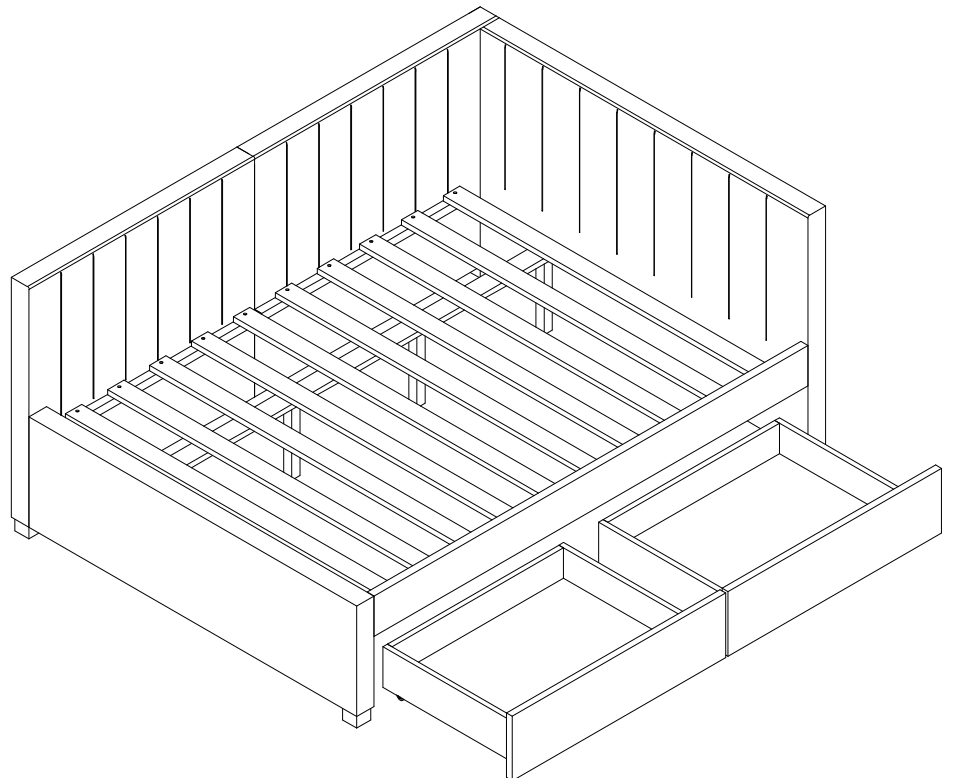

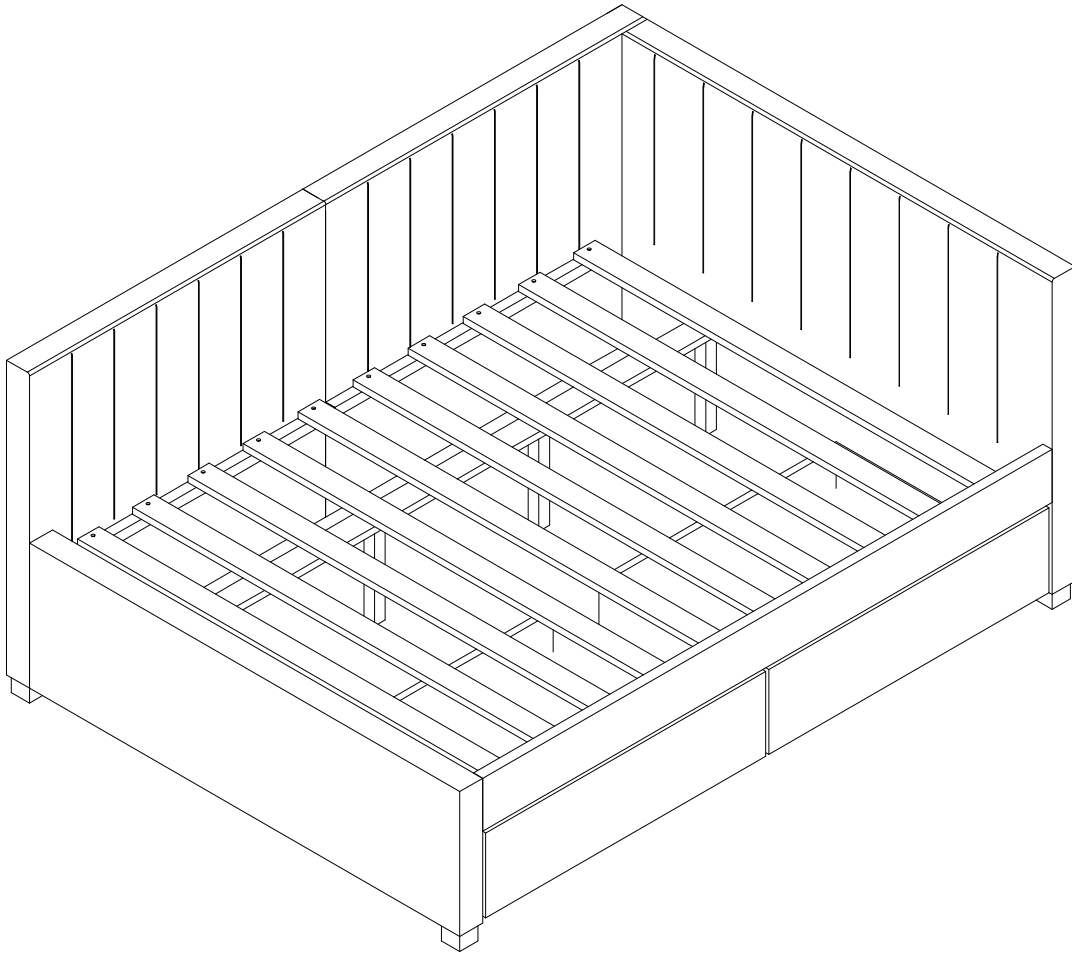

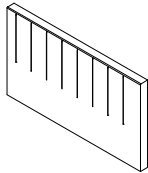
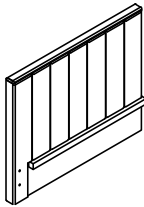
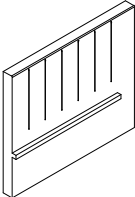
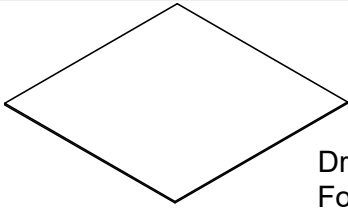

SKU CODE: N708P394303-N708P394304



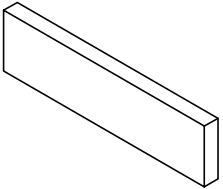

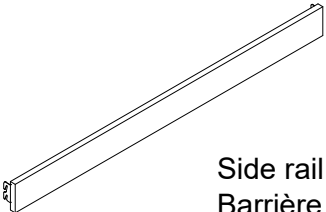
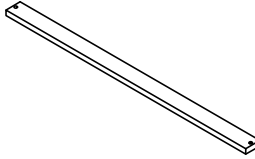
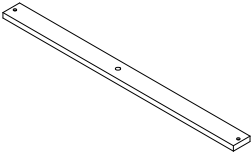
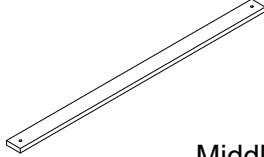

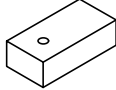

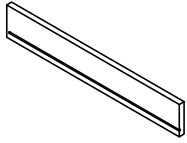
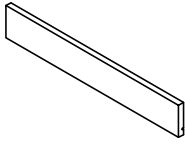
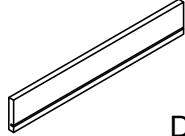
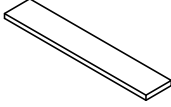
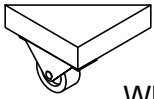



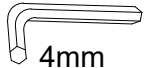
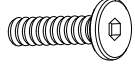
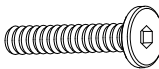
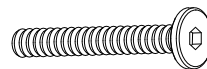

Part Lists/Listes de pièces: N708P394303

2		Headboard Tête de lit - 1pc
3		Back panel 1 Panneau arrière - 1pc
4		Back panel 2 Panneau arrière - 1pc
16		Drawer bottom Fond de tiroir - 2pcs

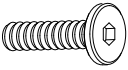
Part Lists/Listes de pièces : N708P394304

<p>1</p>  <p>Footboard Marchepied-1pc</p>	<p>5</p>  <p>Bed leg Pied de lit -4pcs</p>
<p>6</p>  <p>Side rail Barrière latérale-1pc</p>	<p>7</p>  <p>Bed slat 1 Lattes de lit - 6pcs</p>
<p>8</p>  <p>Bed slat 2 Lattes de lit - 4pcs</p>	<p>9</p>  <p>Middle crossbar Traverse centrale -1pc</p>
<p>10</p>  <p>Support leg Jambe d'appui -4pcs</p>	<p>11</p>  <p>Back bottom leg Bas de jambe arrière -1pc</p>
<p>12</p>  <p>Drawer front Façade de tiroir- 2pcs</p>	<p>13</p>  <p>Right drawer side Côté droit du tiroir- 2pcs</p>
<p>14</p>  <p>Left drawer side Côté tiroir gauche - 2pcs</p>	<p>15</p>  <p>Drawer back Dos du tiroir- 2pcs</p>
<p>17</p>  <p>Drawer bottom support bar Barre de support inférieure du tiroir-2pcs</p>	<p>18</p>  <p>Wheel support Support de roue - 8pcs</p>

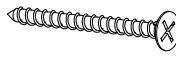
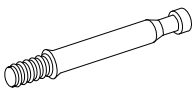
Hardware Lists/Listes de matériel : N708P394304

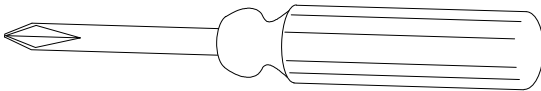
<p>A</p>  <p>4mm</p>	<p>B</p>  <p>Ø5/16" x 20mm</p>
<p>Allen key / Clé Allen (1pc)</p>	<p>Hex-head bolt / Boulon à tête hexagonale(4pcs)</p>
<p>C</p>  <p>Ø5/16" x 40mm</p>	<p>D</p>  <p>Ø5/16" x 50mm</p>
<p>Hex-head bolt / Boulon à tête hexagonale (6pcs)</p>	<p>Hex-head bolt / Boulon à tête hexagonale (5pcs)</p>
<p>E</p>  <p>Ø5/16"</p>	<p>F</p>  <p>Ø5/16"</p>
<p>Spring washer / Rondelle élastique (15pcs)</p>	<p>Flat washer / Rondelle plate(15pcs)</p>
<p>G</p>  <p>Ø5/16" x 75mm</p>	<p>H</p> 
<p>Hanger bolt / Boulon de suspension (2pcs)</p>	<p>Half moon / Demi-lune (2pcs)</p>
<p>I</p>  <p>Ø5/16"</p>	<p>J</p> 
<p>Nut/Noix (2pcs)</p>	<p>Wrench/Clé (1pc)</p>
<p>K</p>  <p>Ø1/4" x 45mm</p>	<p>L</p>  <p>Ø1/4" x 50mm</p>
<p>Hex-head bolt / Boulon à tête hexagonale(4pcs)</p>	<p>Hex-head bolt / Boulon à tête hexagonale (8pcs)</p>
<p>M</p>  <p>Ø1/4"</p>	<p>N</p>  <p>Ø1/4"</p>
<p>Spring washer / Rondelle élastique(4pcs)</p>	<p>Flat washer / Rondelle plate(4pcs)</p>
<p>Q</p>  <p>Ø1/4"</p>	<p>R</p>  <p>Ø4 x 30mm</p>
<p>Barrel nut/Écrou de baril (8pcs)</p>	<p>Wood screw / Vis à bois (44pcs)</p>
<p>S</p> 	<p>T</p> 
<p>Cam bolt / Boulon à came (8pcs)</p>	<p>Cam lock / Serrure à came(8pcs)</p>
	
<p>ASSEMBLY TOOLS REQUIRED (NOT INCLUDED) / OUTILS D'ASSEMBLAGE REQUIS (NON INCLUS)</p>	

Read this instruction carefully. See hardware and furniture part list for guidance. Be sure all parts are complete, before you assemble. Place all wooden furniture parts on a clean and flat soft surface to prevent from being scratched.

Follow the figure to start assembling.

CAUTIONS :

1. Do not **FULLY - TIGHTEN** the nut or nut bolt until all nut or bolt is ready assembled.
2. Do not **OVER - TIGHTEN** the nut or bolt to avoid causing damages to the thread.
3. Keep all hardware parts out of reach of children.

NOTE : THE LIST AND QUANTITY SHOWN ARE FOR 1 UNIT ASSEMBLY.



Lisez attentivement ces instructions. Consultez la liste des pièces de quincaillerie et de mobilier pour obtenir des conseils. Assurez-vous que toutes les pièces sont complètes avant de les assembler. Placez tous les meubles en bois pièces sur une surface douce, propre et plate pour éviter d'être rayée. Suivez la figure pour commencer l'assemblage.

PRÉCAUTIONS :

1. Ne **SERREZ PAS COMPLÈTEMENT** l'écrou ou le boulon avant que tous les écrous ou boulons ne soient prêts à être assemblés.
2. Ne **SERREZ PAS TROP** l'écrou ou le boulon pour éviter d'endommager le filetage.
3. Gardez toutes les pièces matérielles hors de portée des enfants.

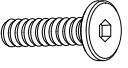

REMARQUE : LA LISTE ET LA QUANTITÉ INDIQUÉE SONT POUR 1 ASSEMBLAGE D'UNITÉ.

STEP: 1
ÉTAPE: 1

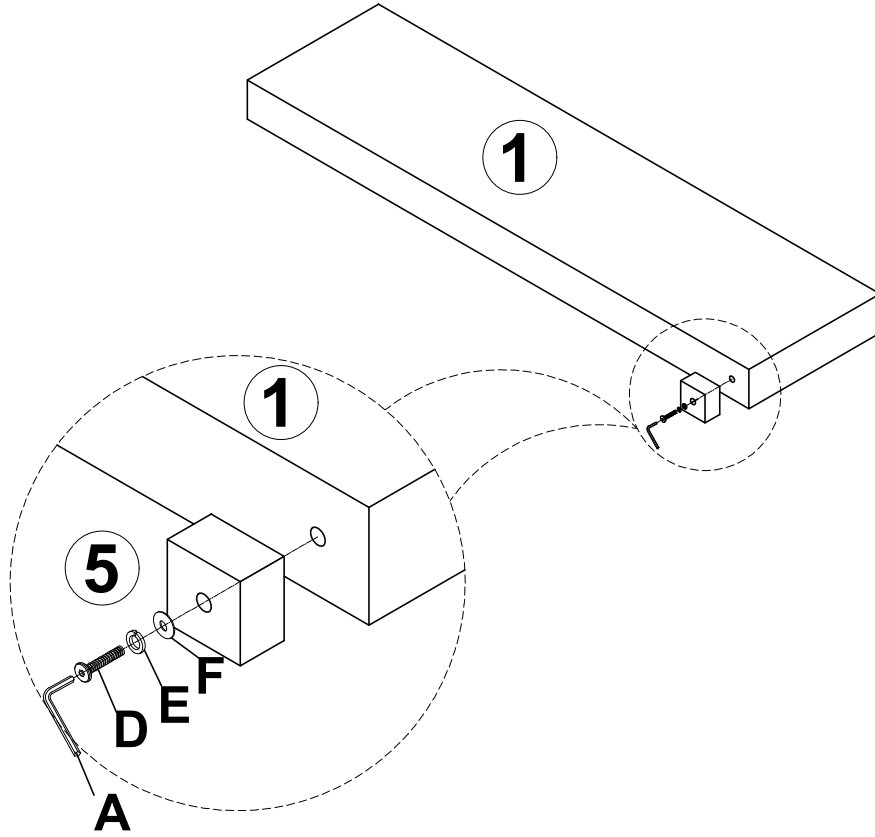
F		E		D	
	1PC		1PC		1PC



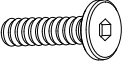

STEP: 2
ÉTAPE: 2

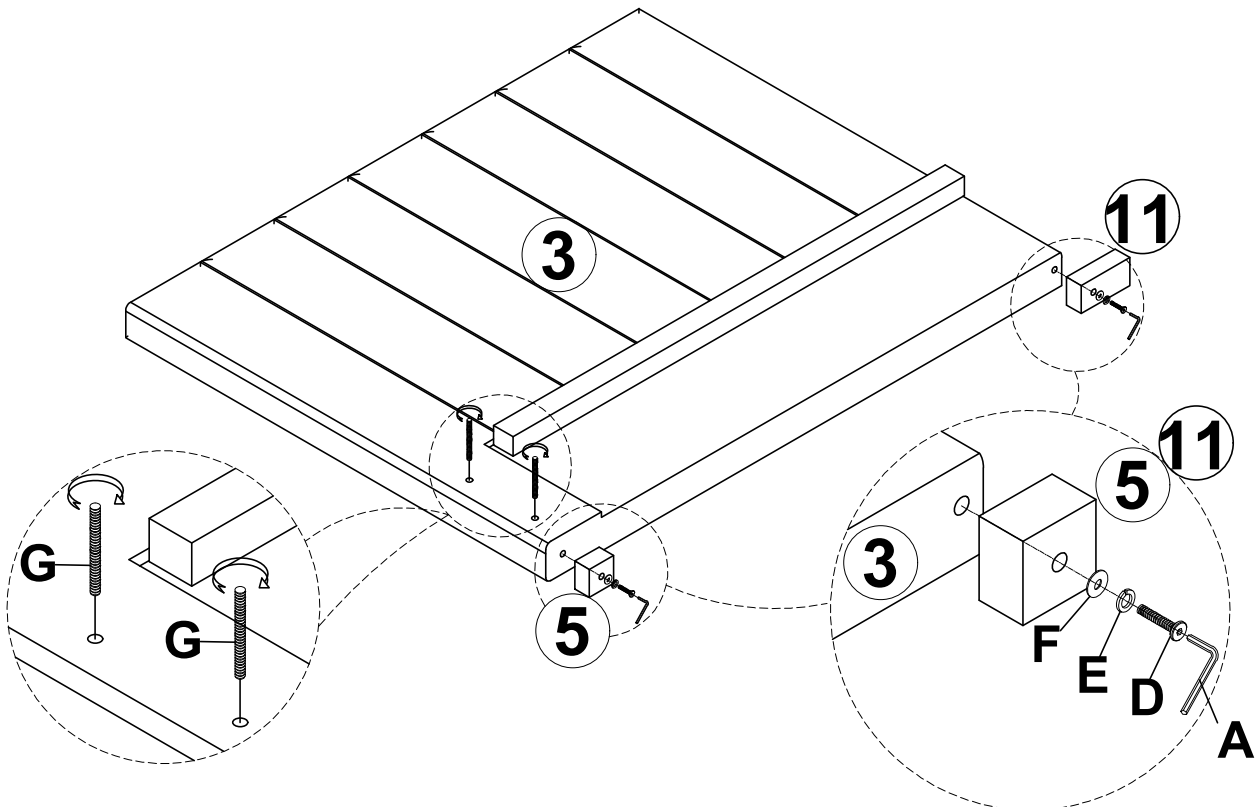
G		F		E		D	
	2PCS		2PCS		2PCS		2PCS



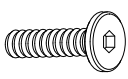

STEP: 3
ÉTAPE: 3

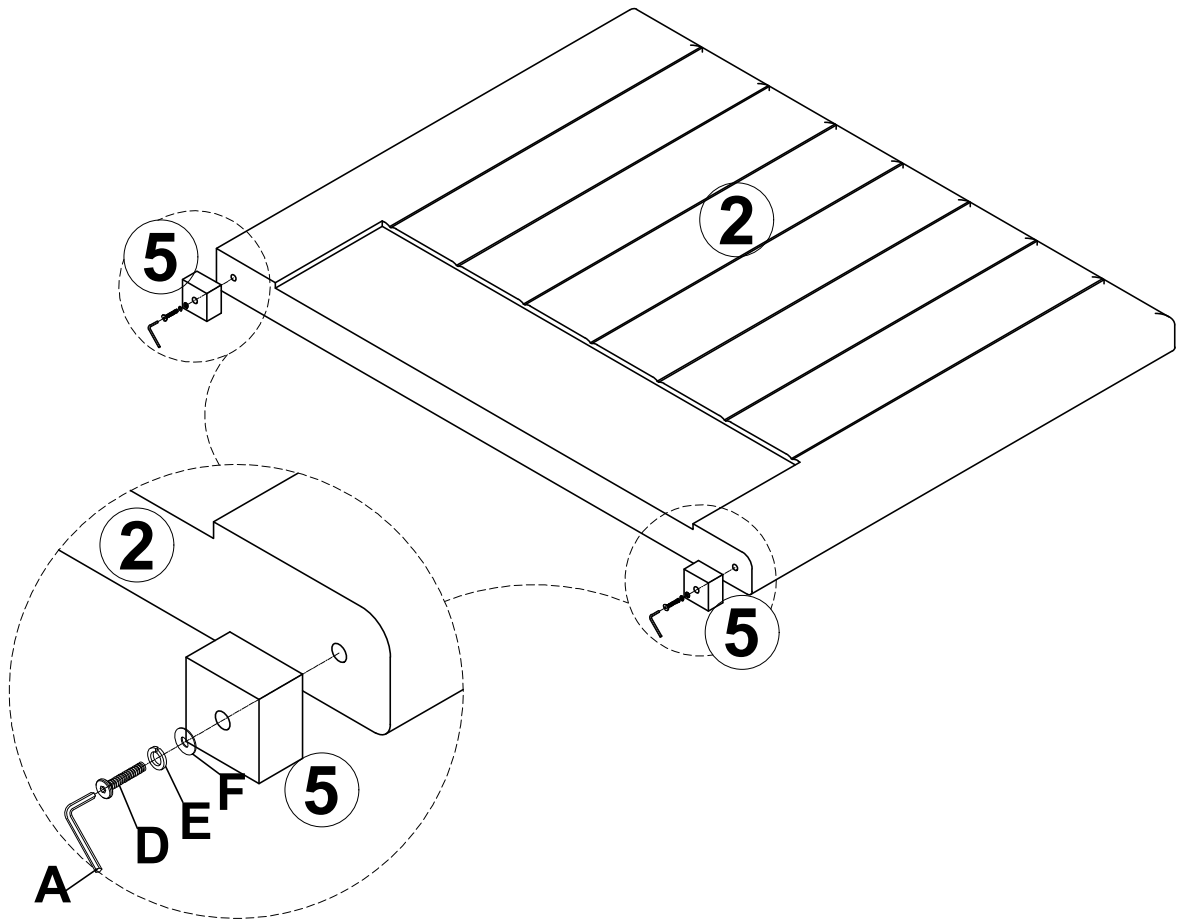
F 	E 	D 
2PCS	2PCS	2PCS



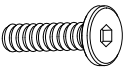

STEP: 4
ÉTAPE: 4

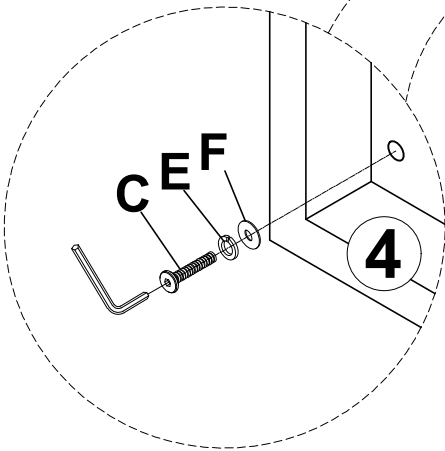
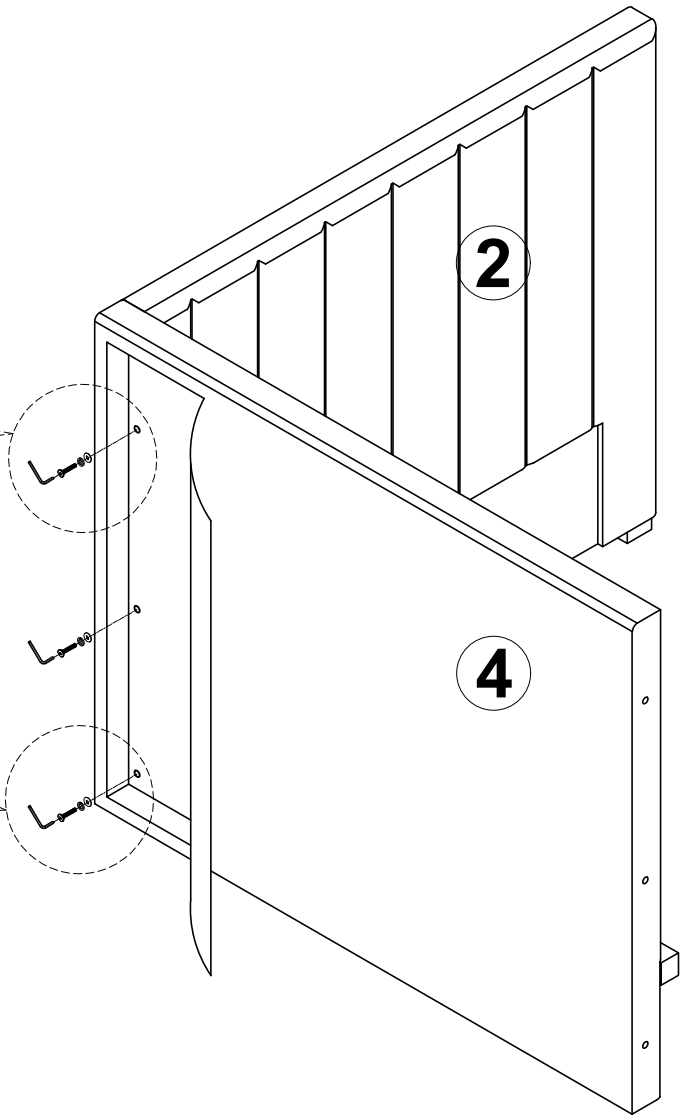
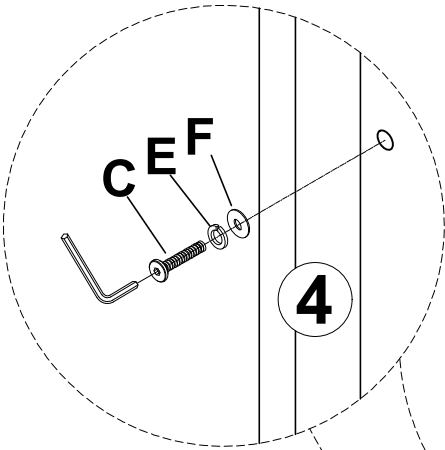
F 	E 	C 
3PCS	3PCS	3PCS



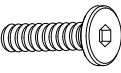

STEP: 5
ÉTAPE: 5

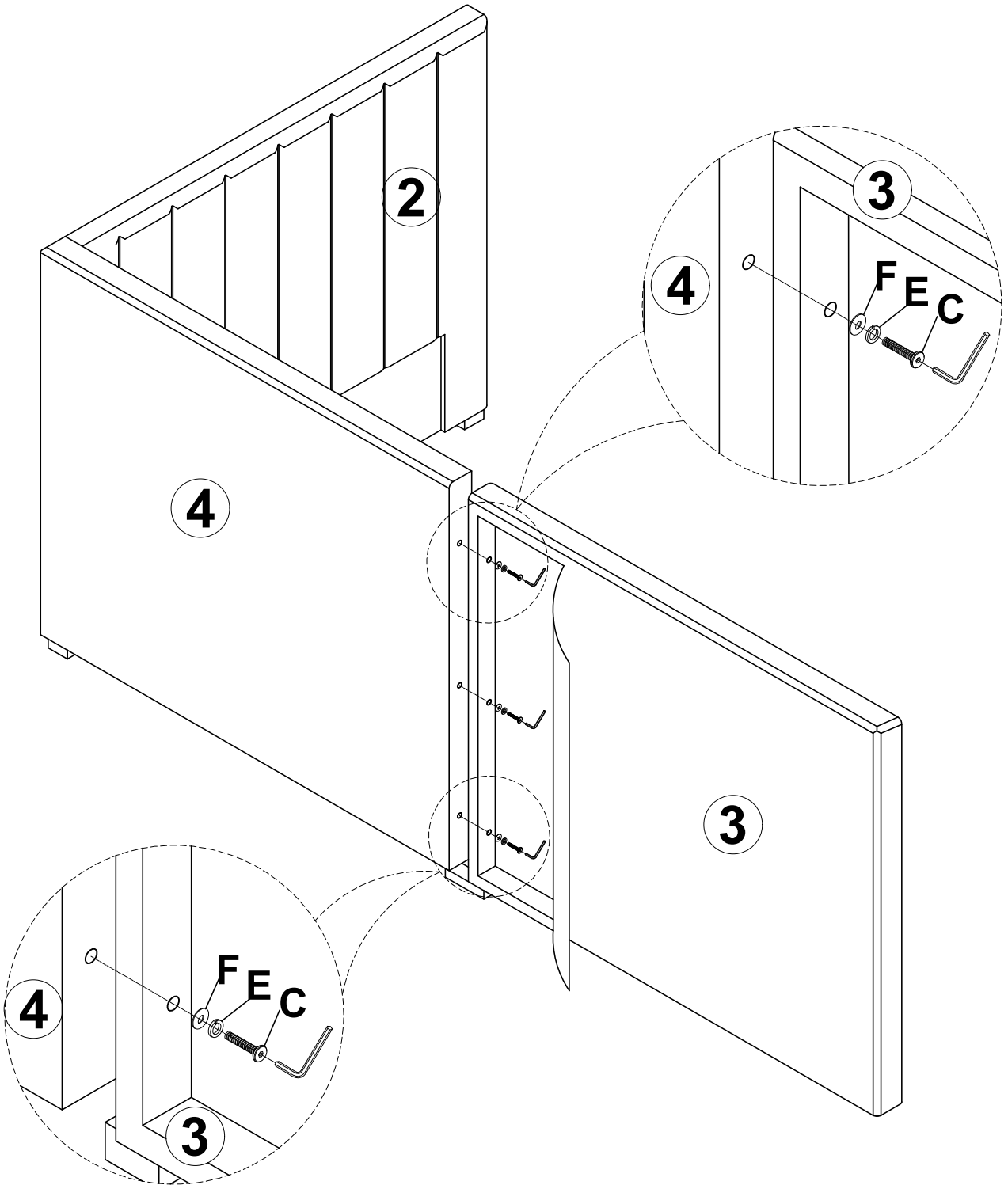
F 	E 	C 
3PCS	3PCS	3PCS



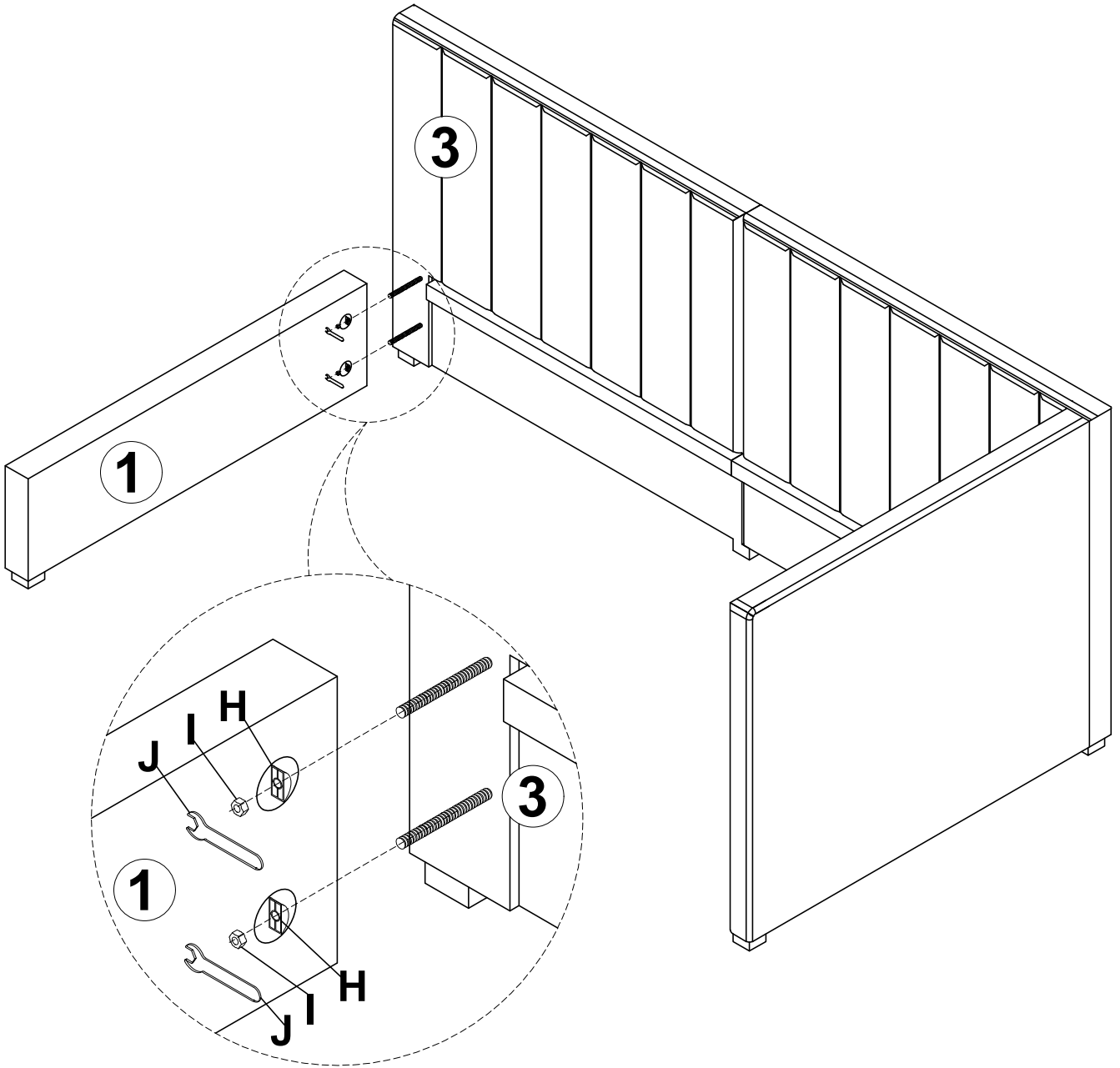

STEP: 6
ÉTAPE: 6

J 	I 	H 
1PC	2PCS	2PCS



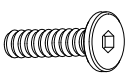

STEP: 7
ÉTAPE: 7

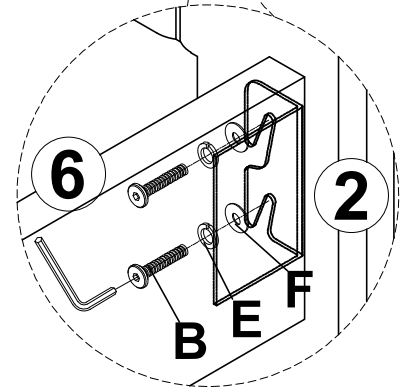
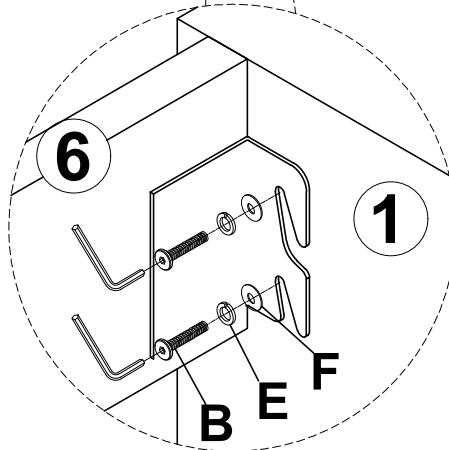
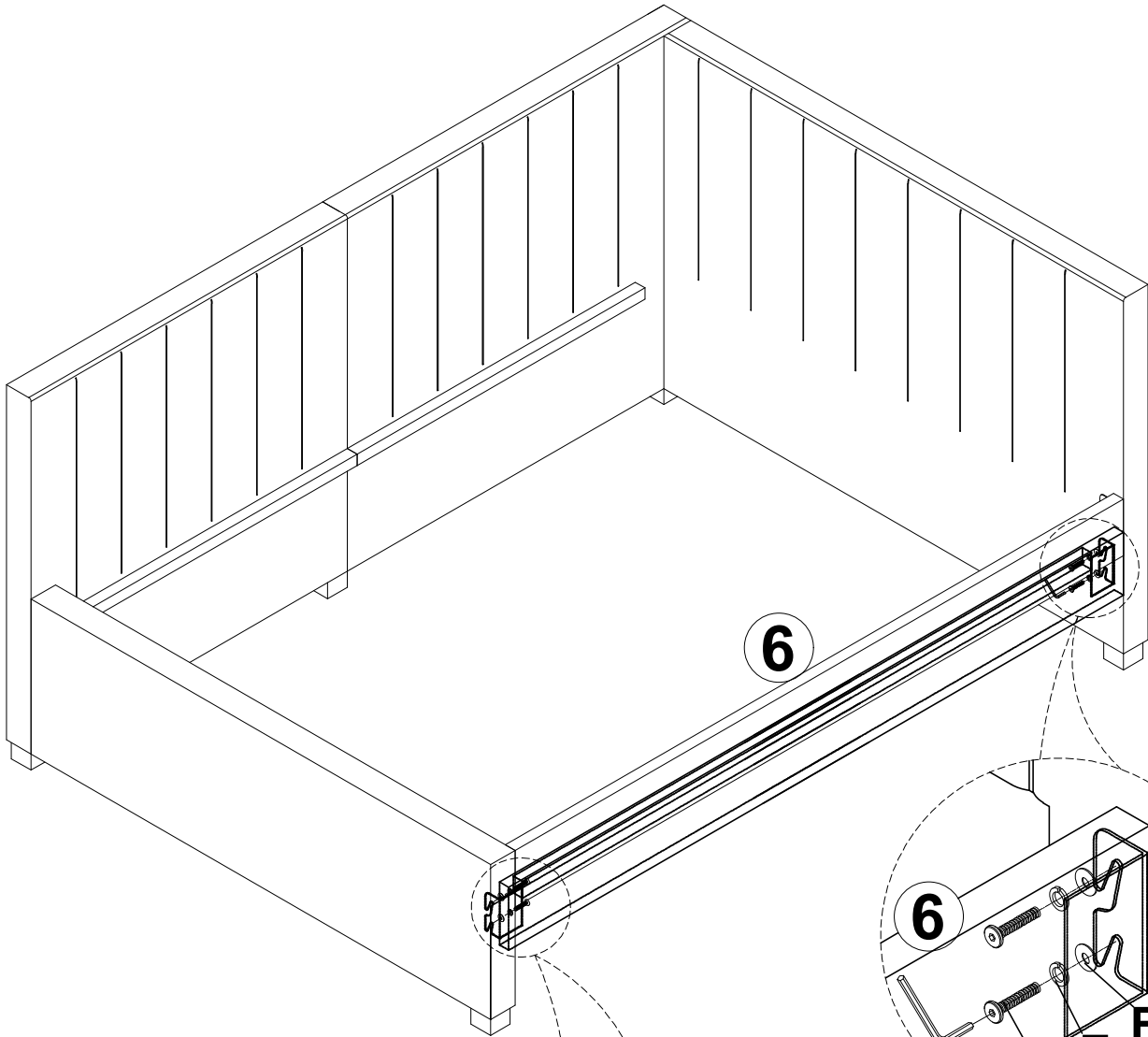
F 	E 	B 
4PCS	4PCS	4PCS



STEP: 8

ÉTAPE: 8

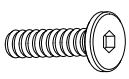
N		M		K	
4PCS		4PCS		4PCS	

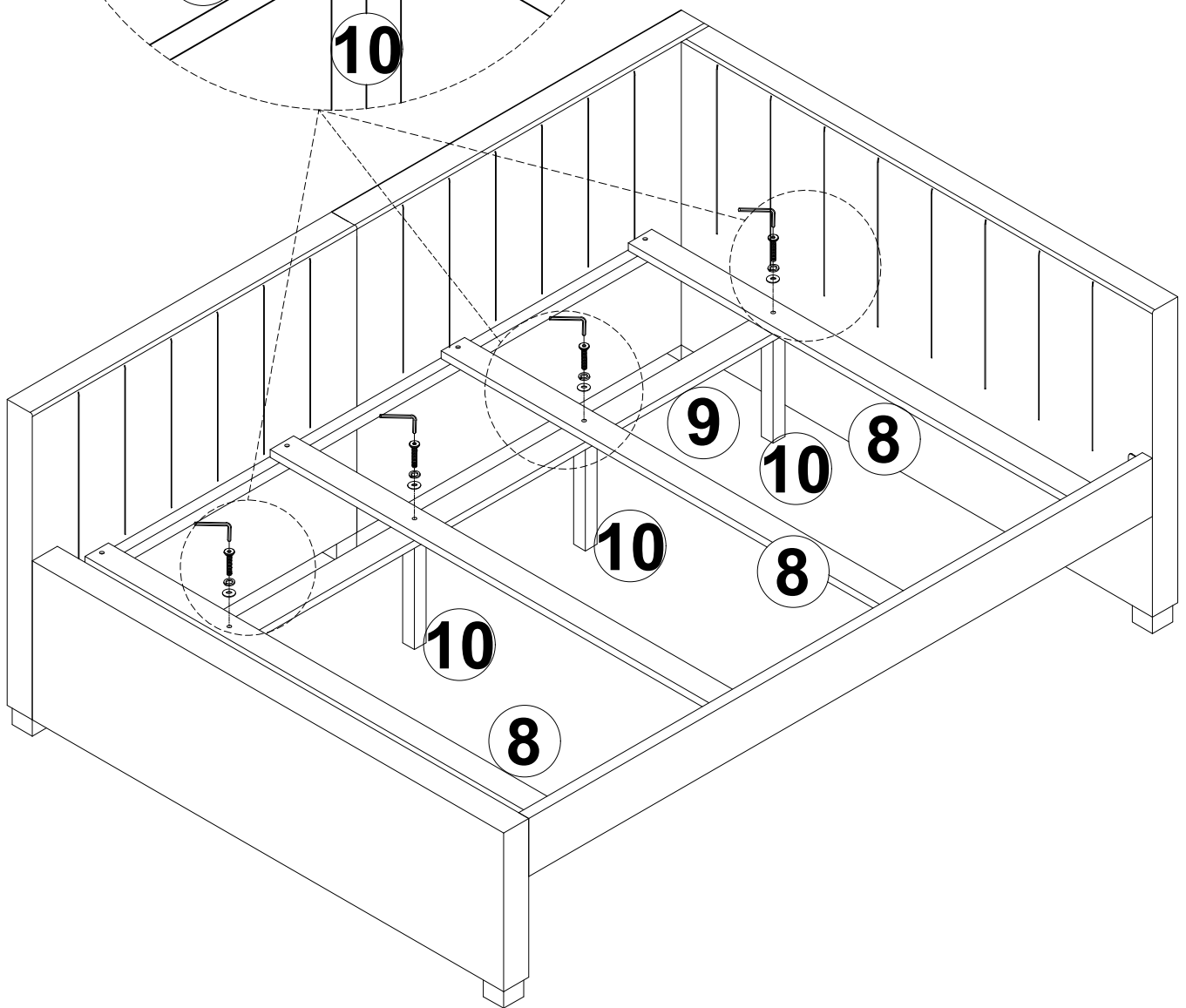
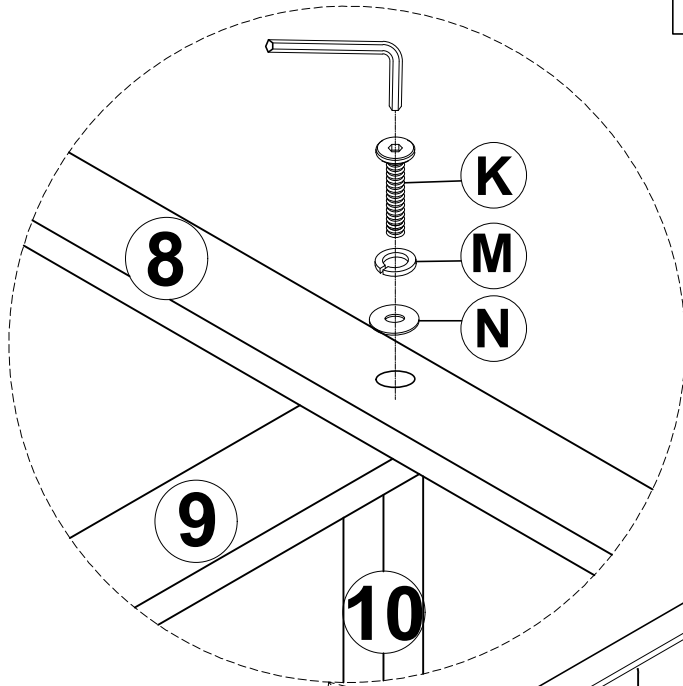

STEP: 9
ÉTAPE: 9

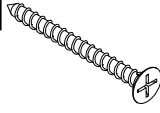
R	
20PCS	

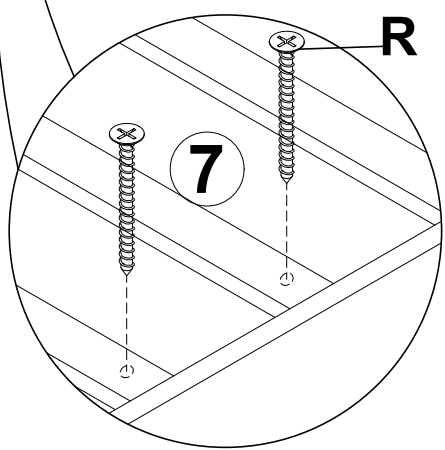
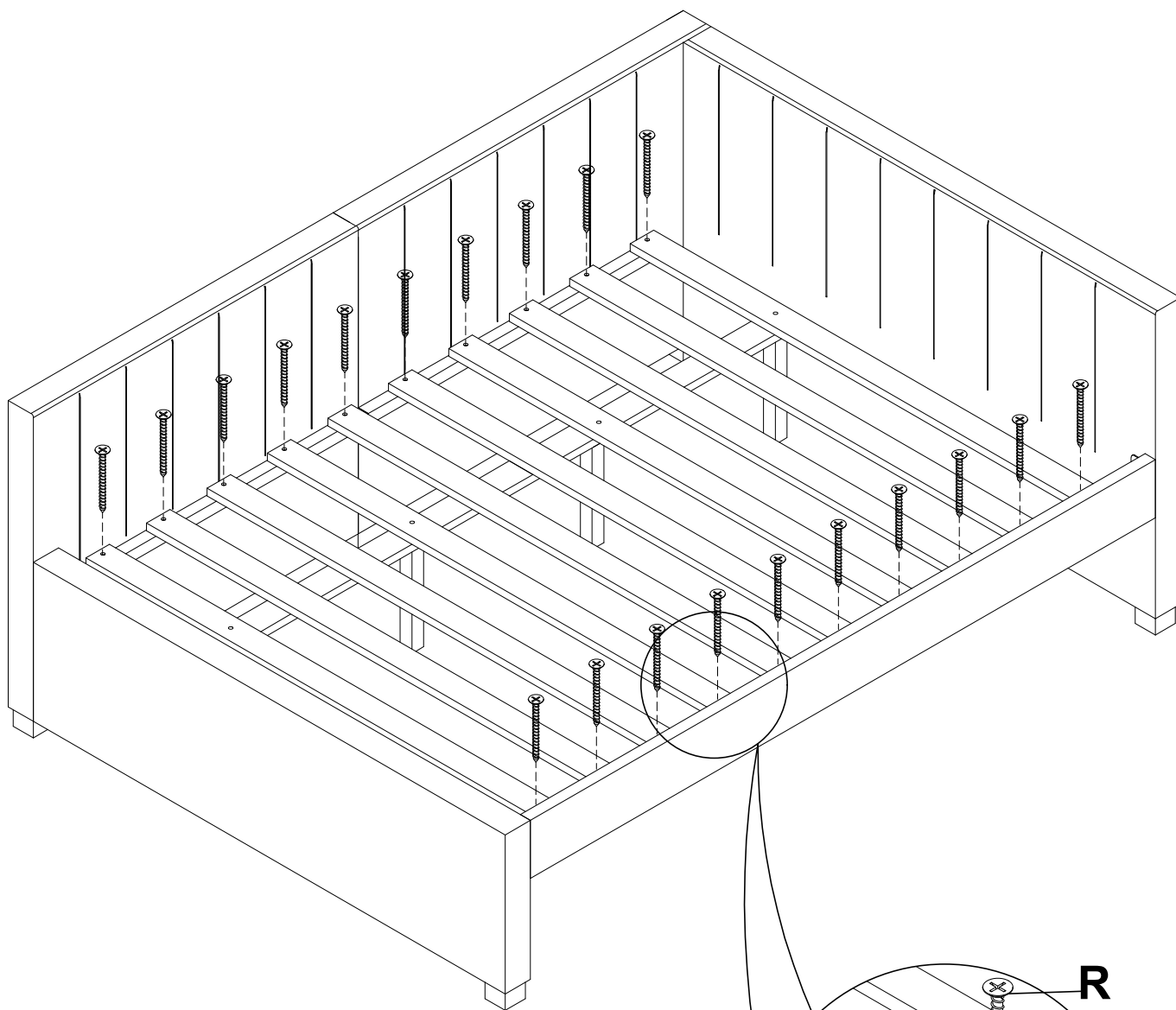

STEP: 10
ÉTAPE: 10

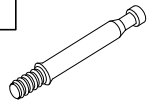
S	
8PCS	

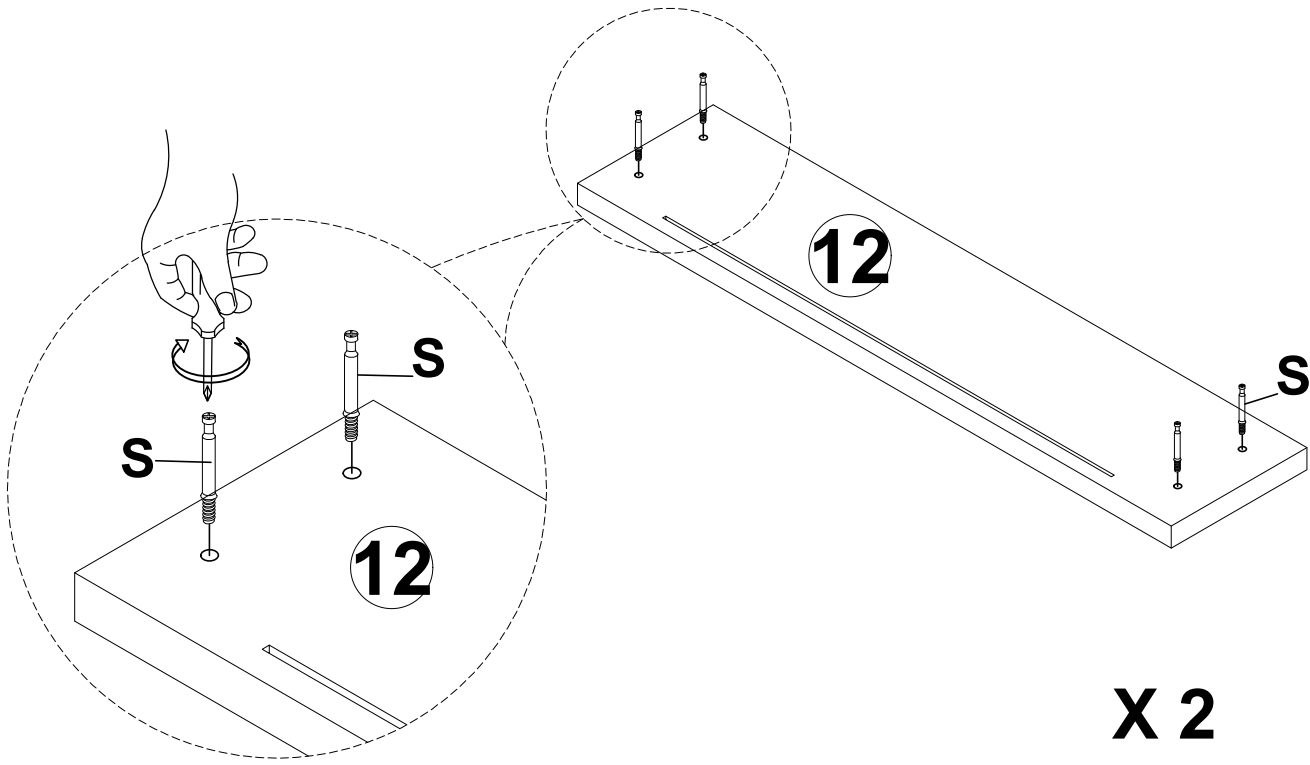

STEP: 11
ÉTAPE: 11

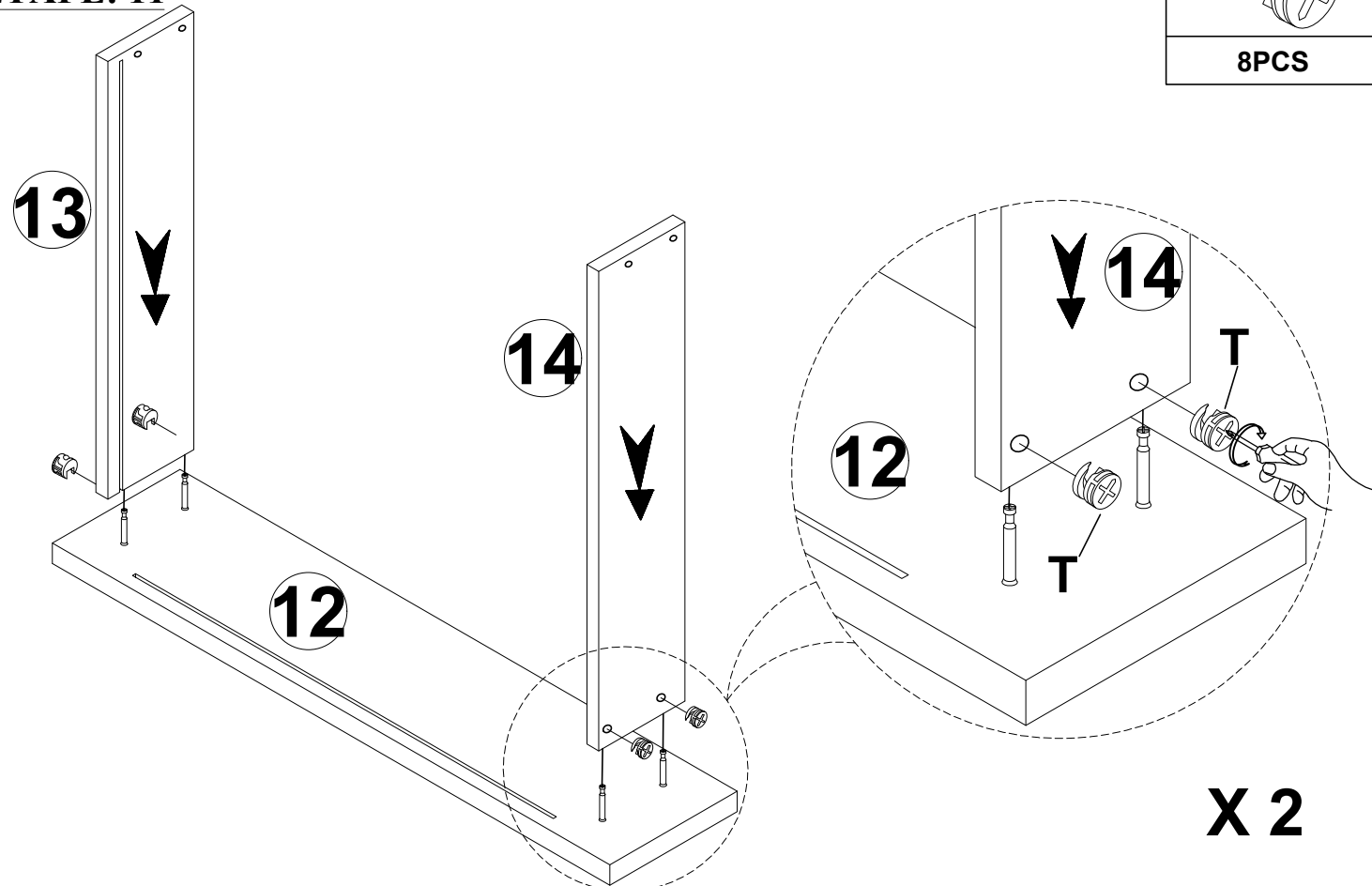

T	
8PCS	

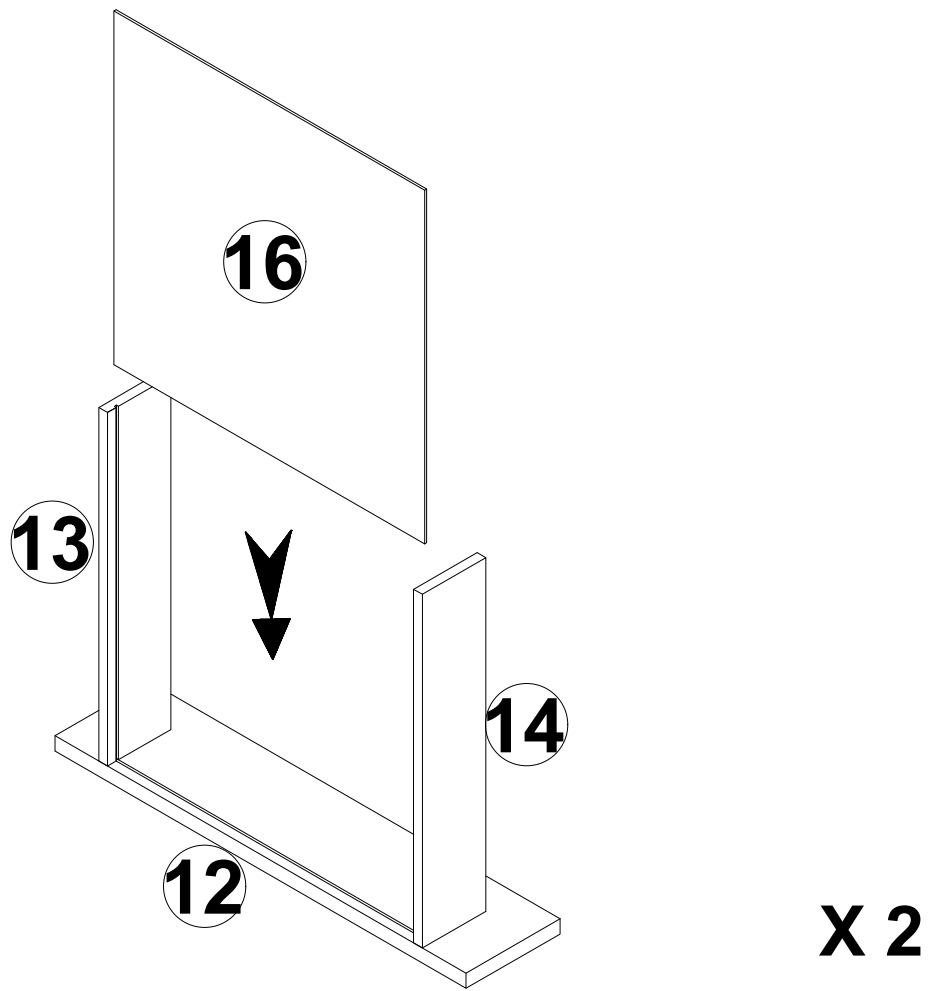

STEP: 12
ÉTAPE: 12



STEP: 13
ÉTAPE: 13

Q	L
	
8PCS	8PCS

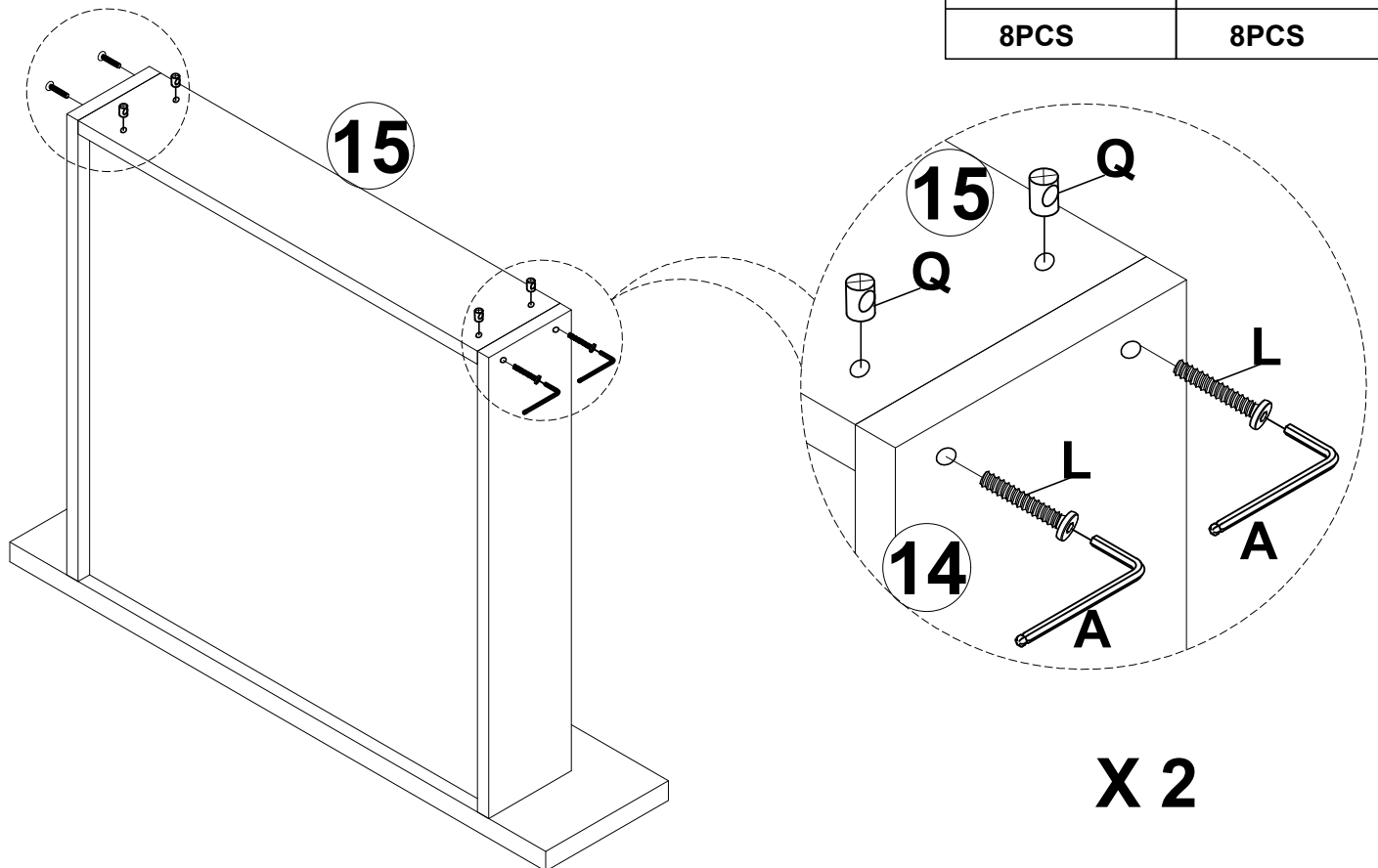

STEP: 14
ÉTAPE: 14

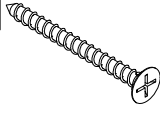
R	
16PCS	

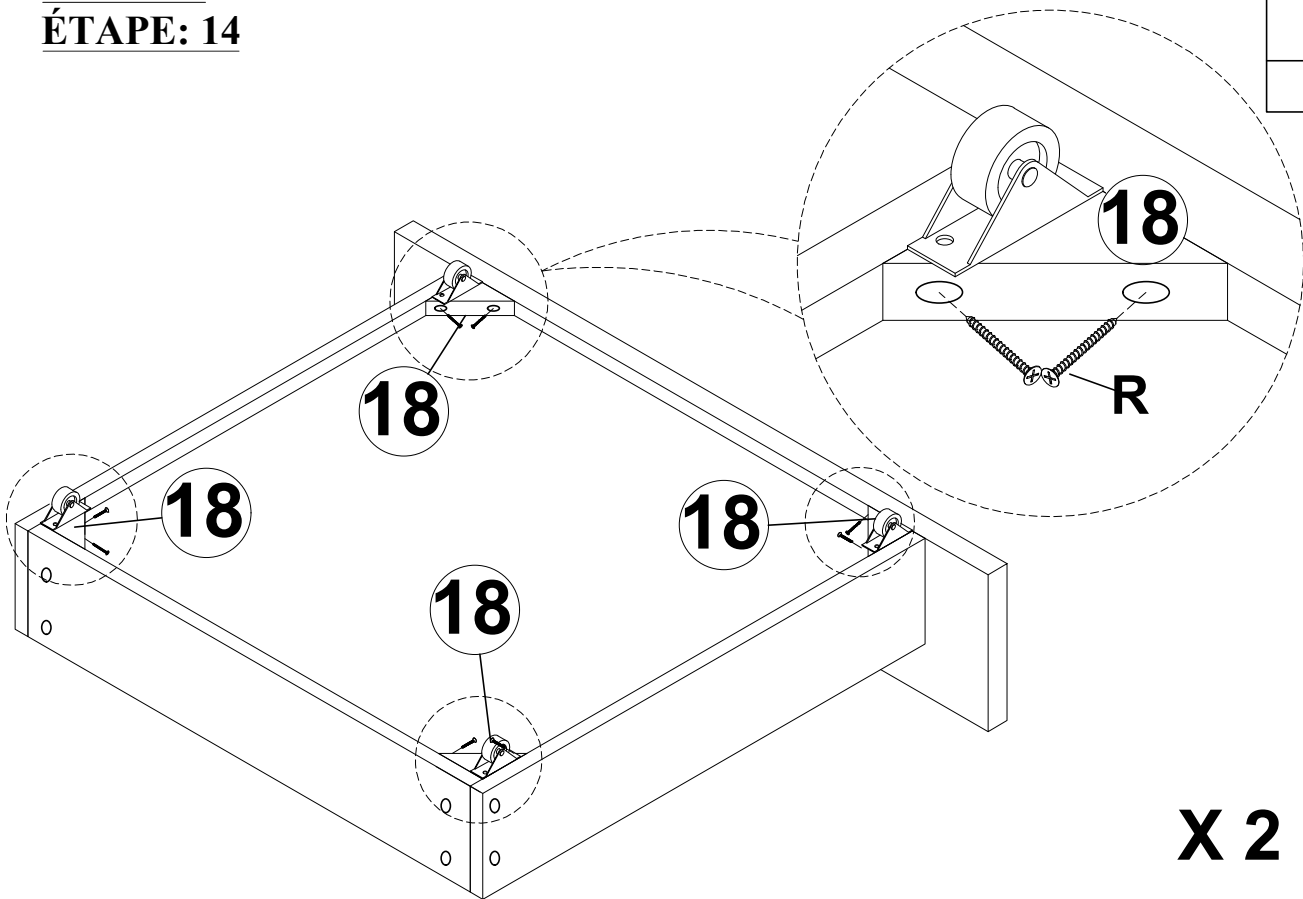

X 2

STEP: 15
ÉTAPE: 15

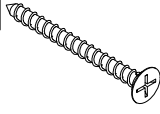
R	
8PCS	

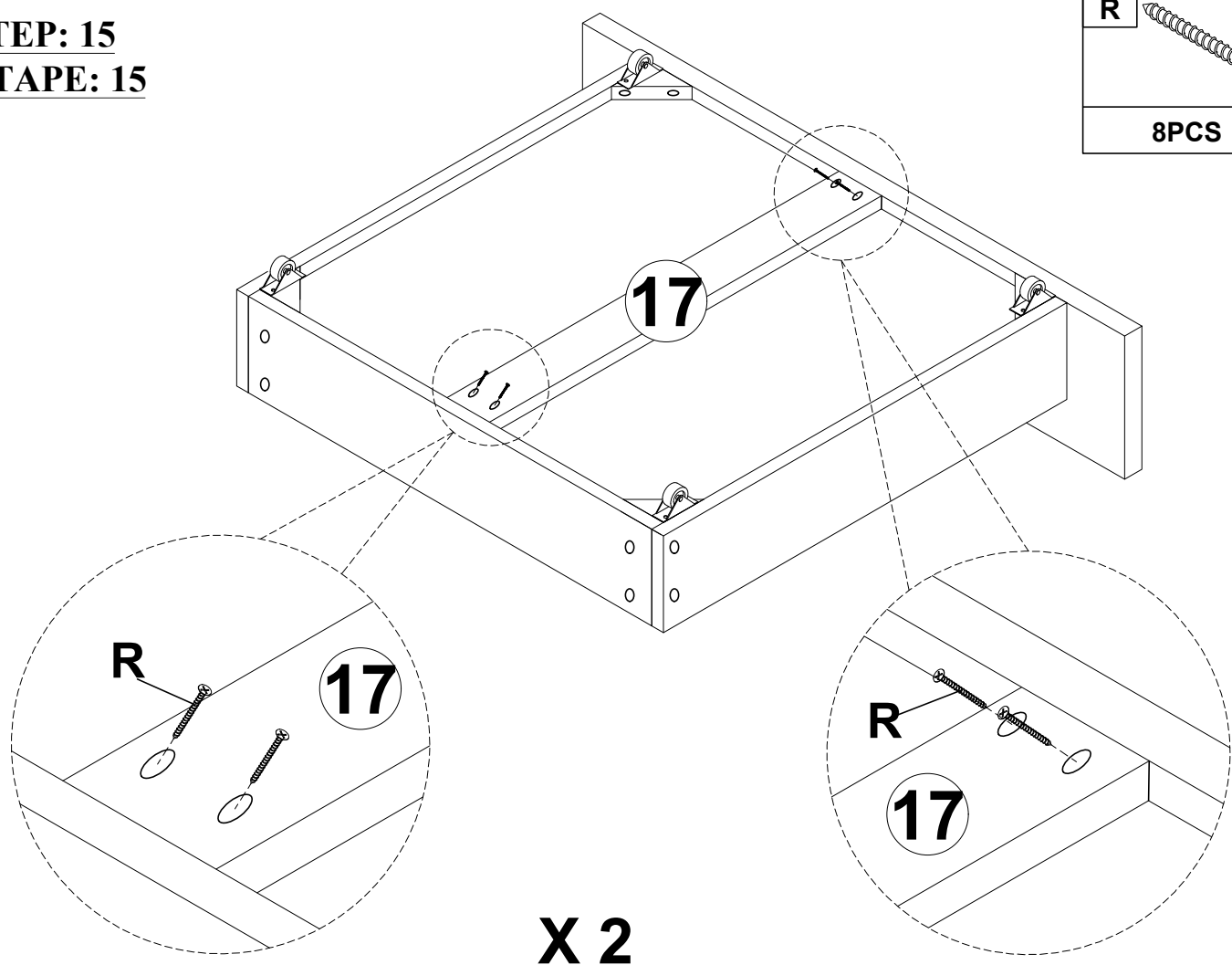

X 2

STEP: 16

ÉTAPE: 16

