

I870101125A1/A2

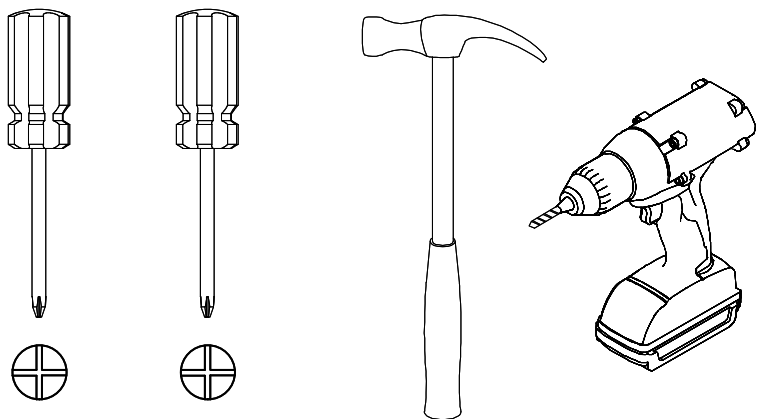

**Tools required
(not included)**

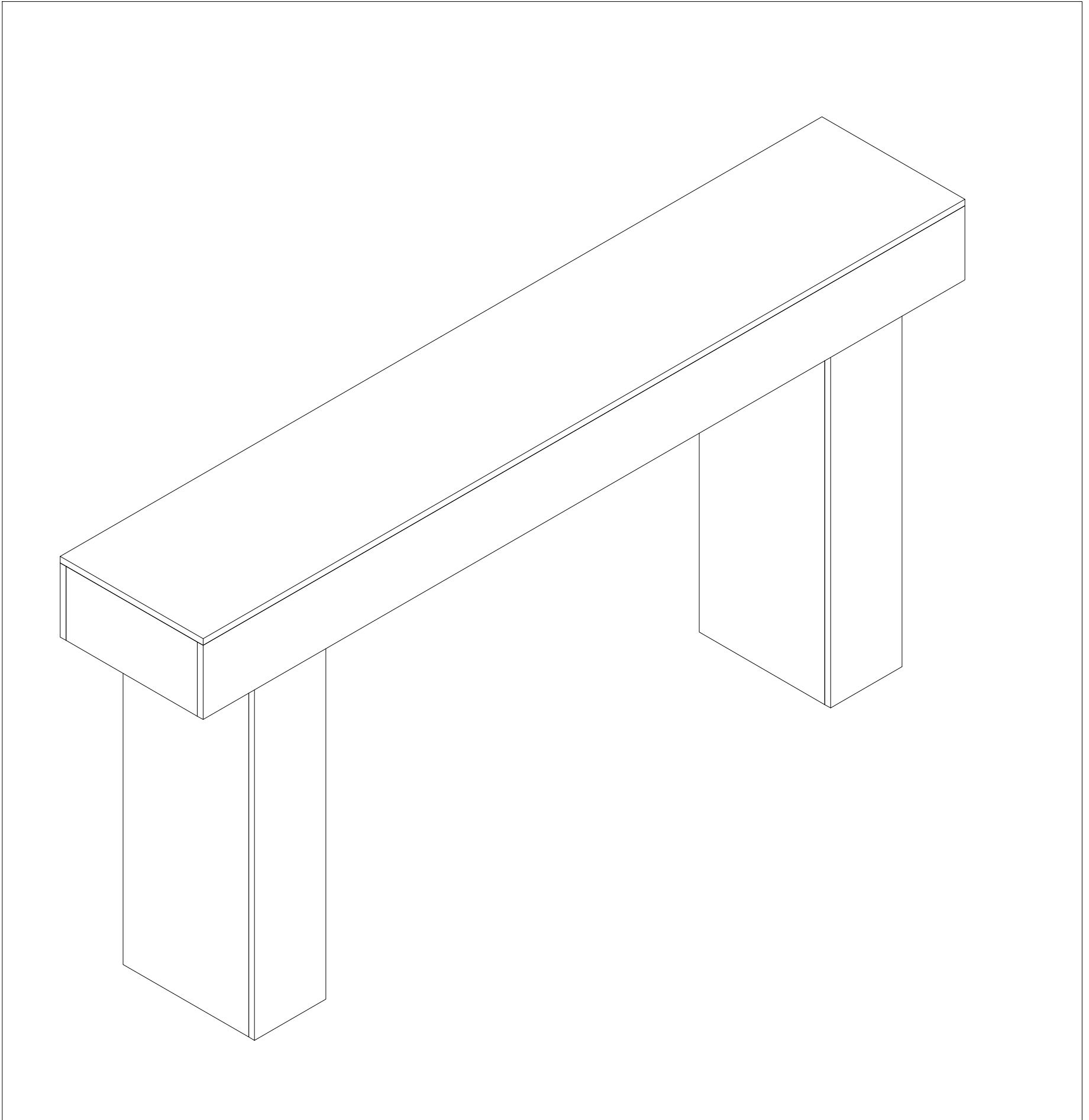

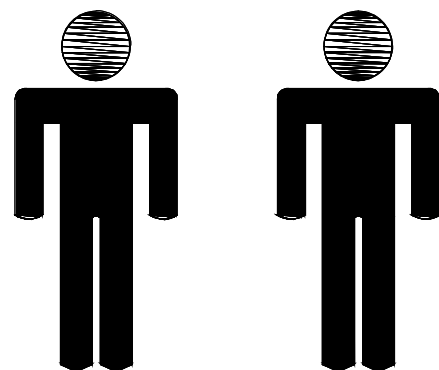

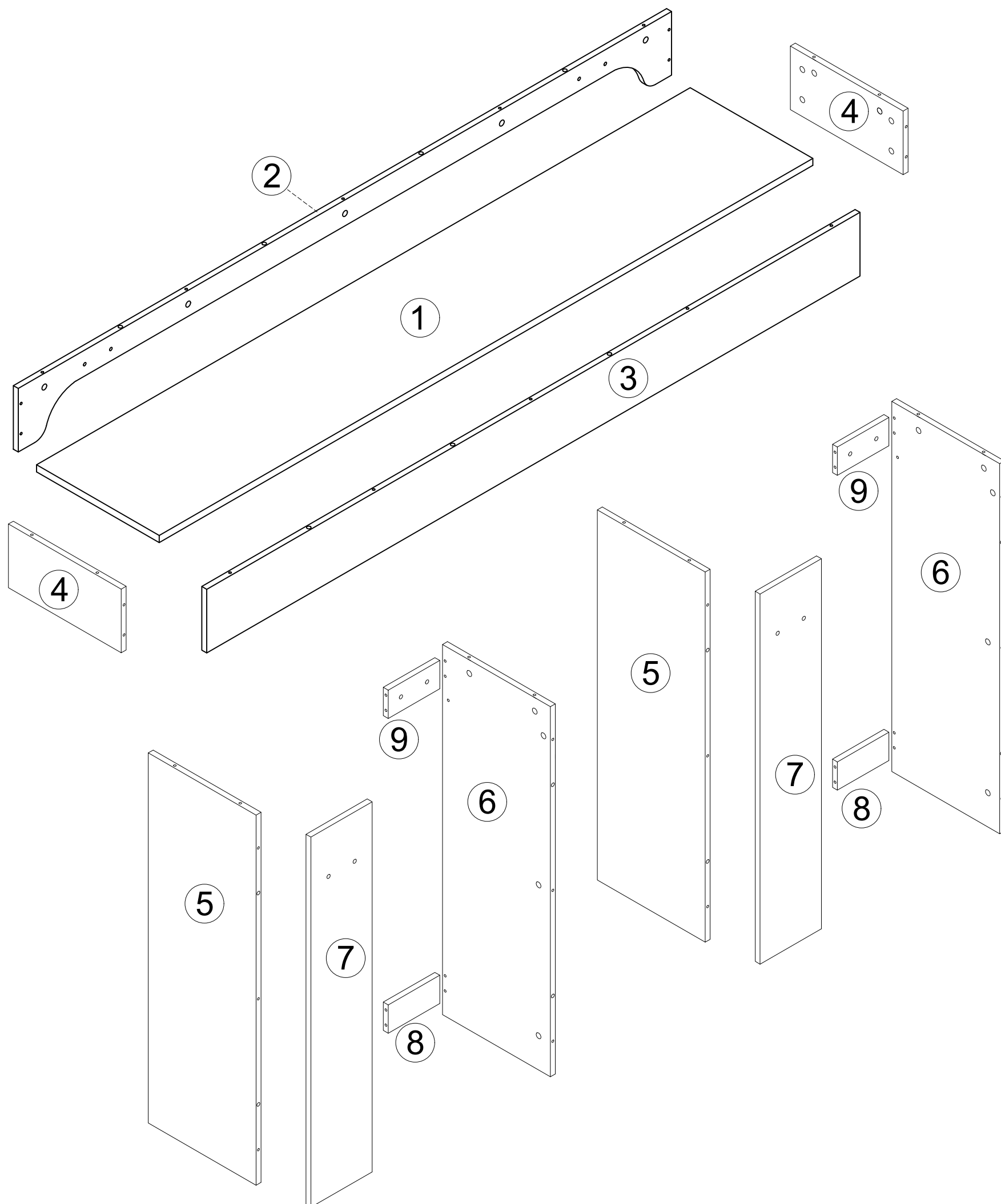
2 people for assembly

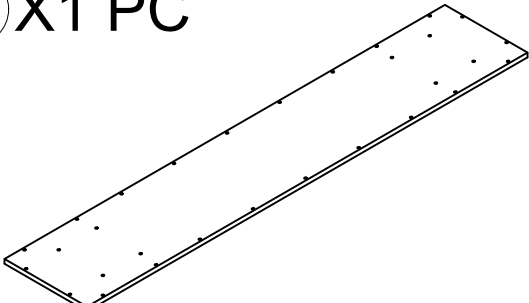
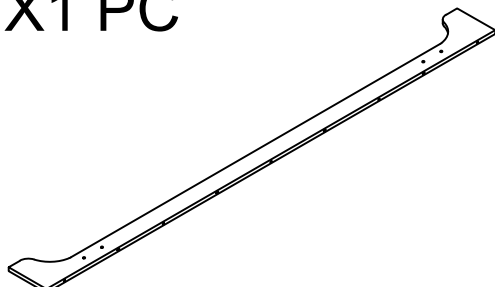
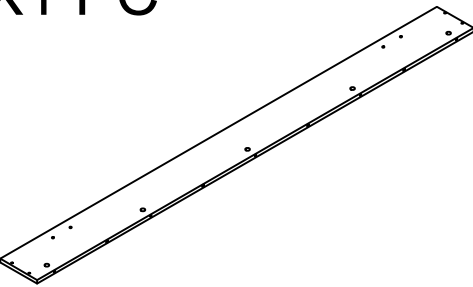
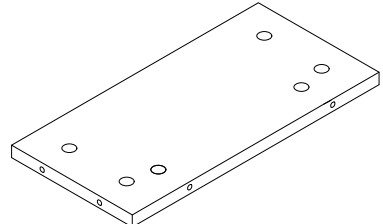
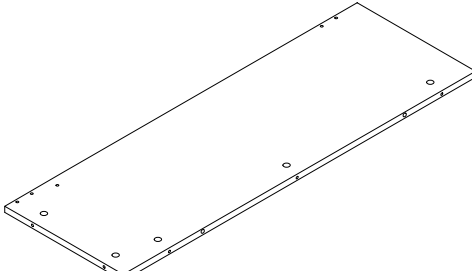
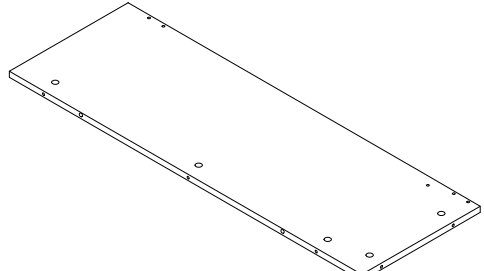
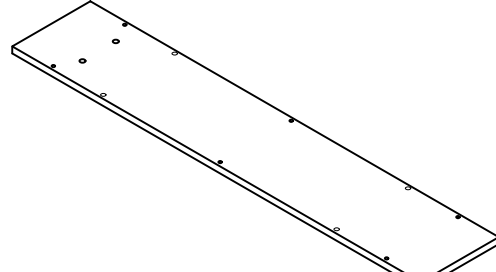
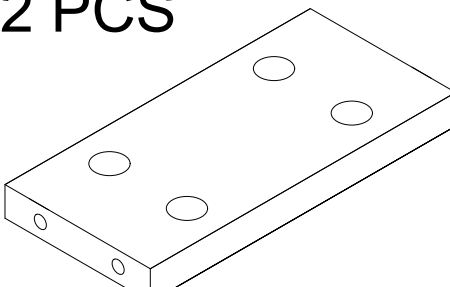
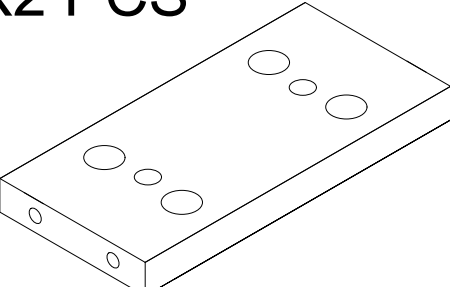

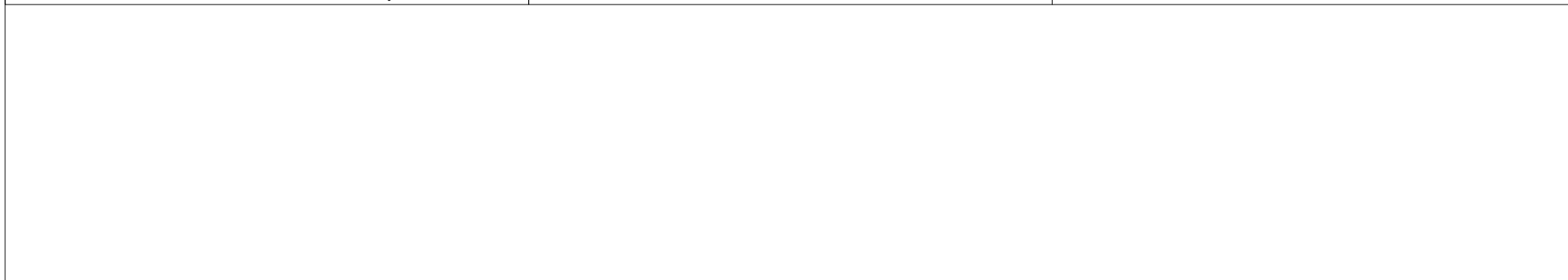
<p>① X1 PC</p> 	<p>② X1 PC</p> 	<p>③ X1 PC</p> 
<p>④ X2 PCS</p> 	<p>⑤ X2 PCS</p> 	<p>⑥ X2 PCS</p> 
<p>⑦ X2 PCS</p> 	<p>⑧ X2 PCS</p> 	<p>⑨ X2 PCS</p> 

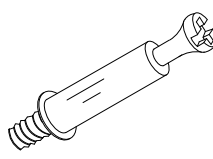

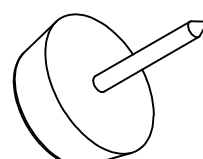
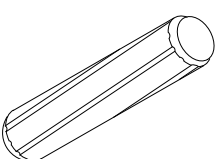
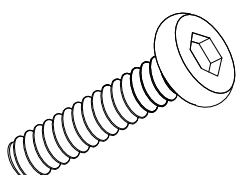
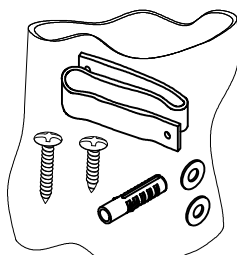
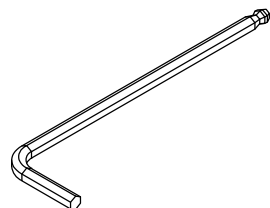
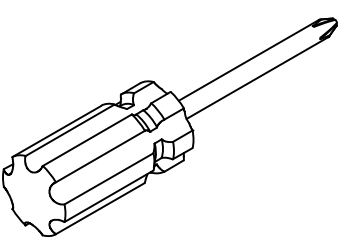
<p>A</p>  <p>Ø6*35mm 58+7 PCS</p>	<p>B</p>  <p>Ø15*9mm 58+7 PCS</p>	<p>C</p>  <p>Ø12*5mm 8+2 PCS</p>	<p>D</p>  <p>Ø6*30mm 16+2 PCS</p>
<p>E</p>  <p>M6*20mm 8+1 PC</p>	<p>F</p>  <p>2 SET</p>	<p>G</p>  <p>M4*30*110 1 PC</p>	 <p>1 PC</p>

Instructions For Fastening CAM-BOLT and CAM-LOCK

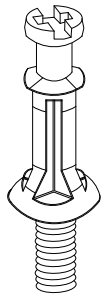

CAM-BOLT

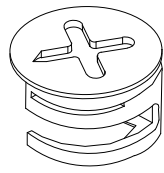

CAM-LOCK

Tools Required

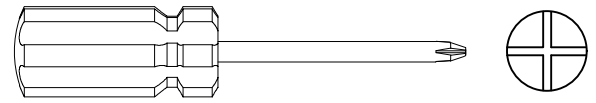

INSERTING AND TIGHTENING CAM-BOLT

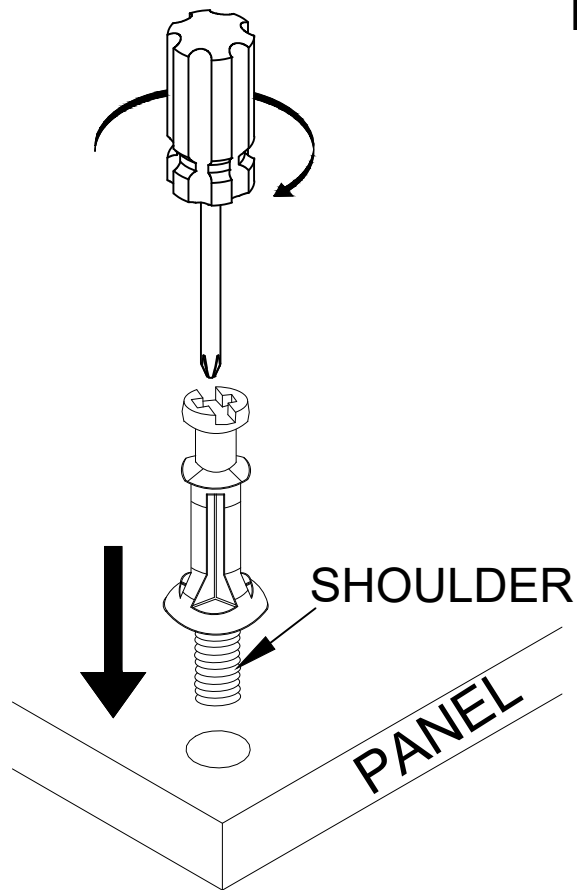

Place Cam-bolt on pre-drilled hole and screw in vertically

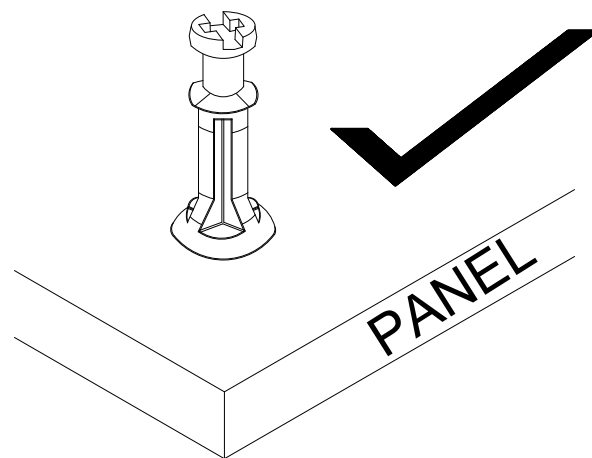

Shoulder is flushed (on the same level) with the panel.

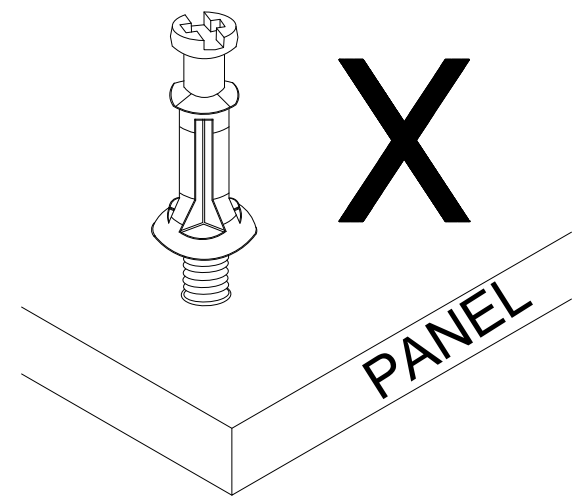

Shoulder is above the panel.

Place Cam-bolt on the designated pre-drilled holes on the panel. Use a Phillips Screwdriver to screw-in Cam-bolt vertically until shoulder is flushed (on the same level) with panel.

INSERTING CAM-LOCK

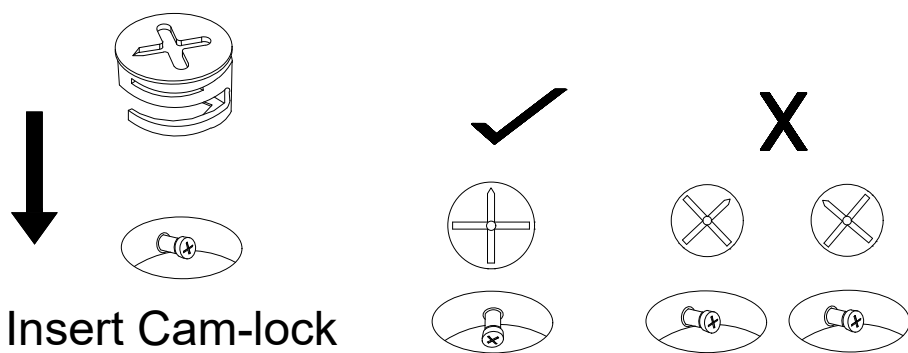

Insert Cam-lock with arrow align to Cam-bolt head **CORRECT** **WRONG**

Align the arrow on the Cam-lock to the Cam-bolt head and insert the Cam-lock. Ensure Cam-lock is fully inserted.

TIGHTENING CAM-LOCK

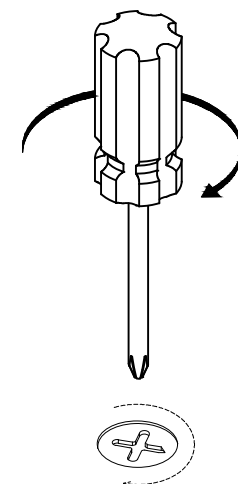

Use a Flat-head Screwdriver to turn Camlock clockwise so it locks onto the head of the Cam-bolt. Turn until it is snug (about 3/4ths of a turn) -- over-tightening could damage Cam-lock or/and Cam-bolt.

1

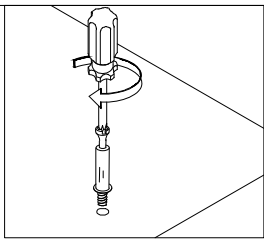

A x34

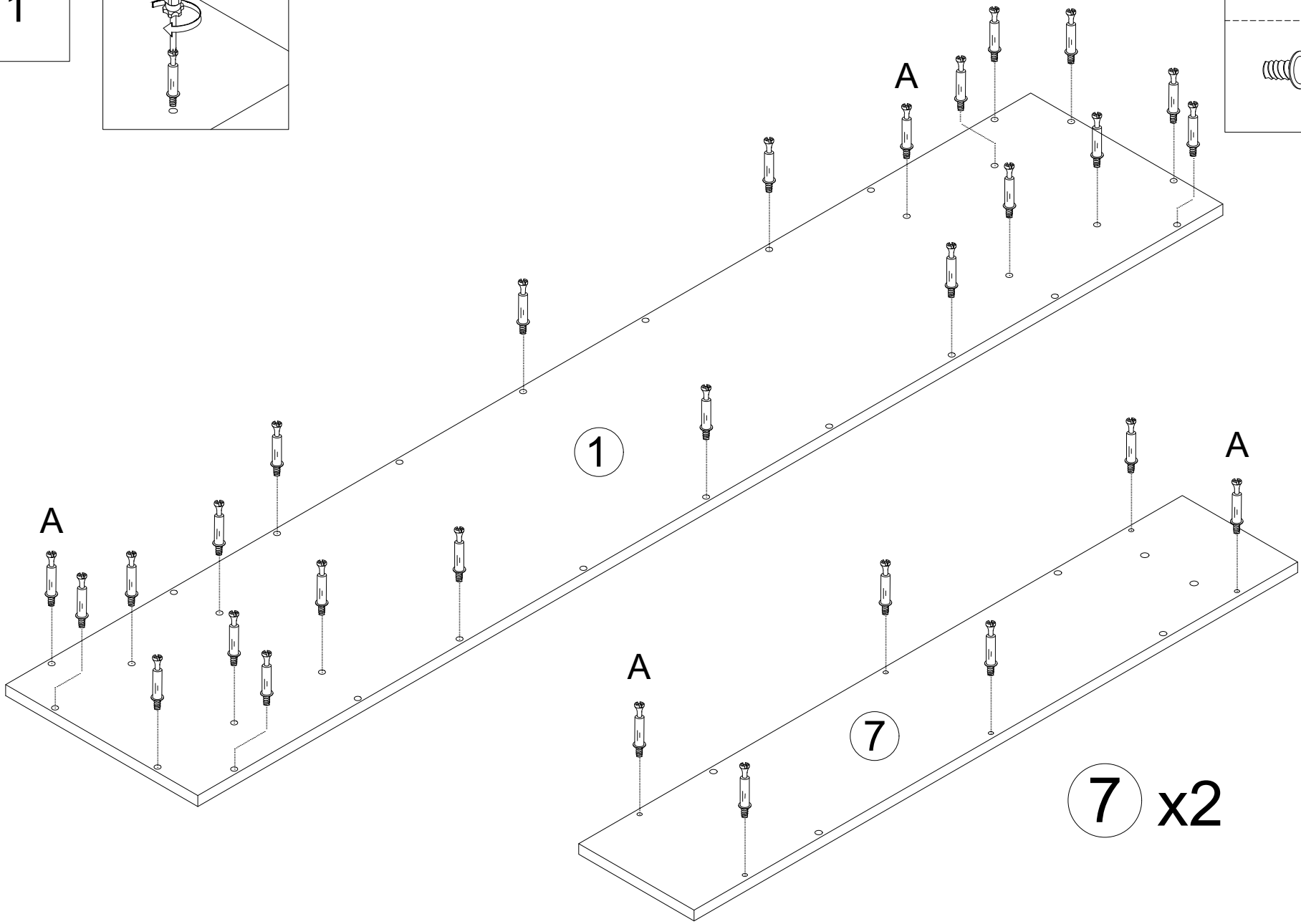
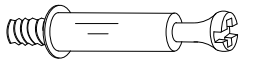

2

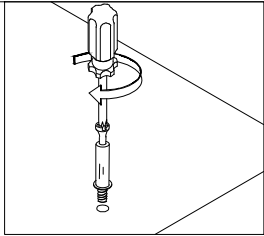

A x8

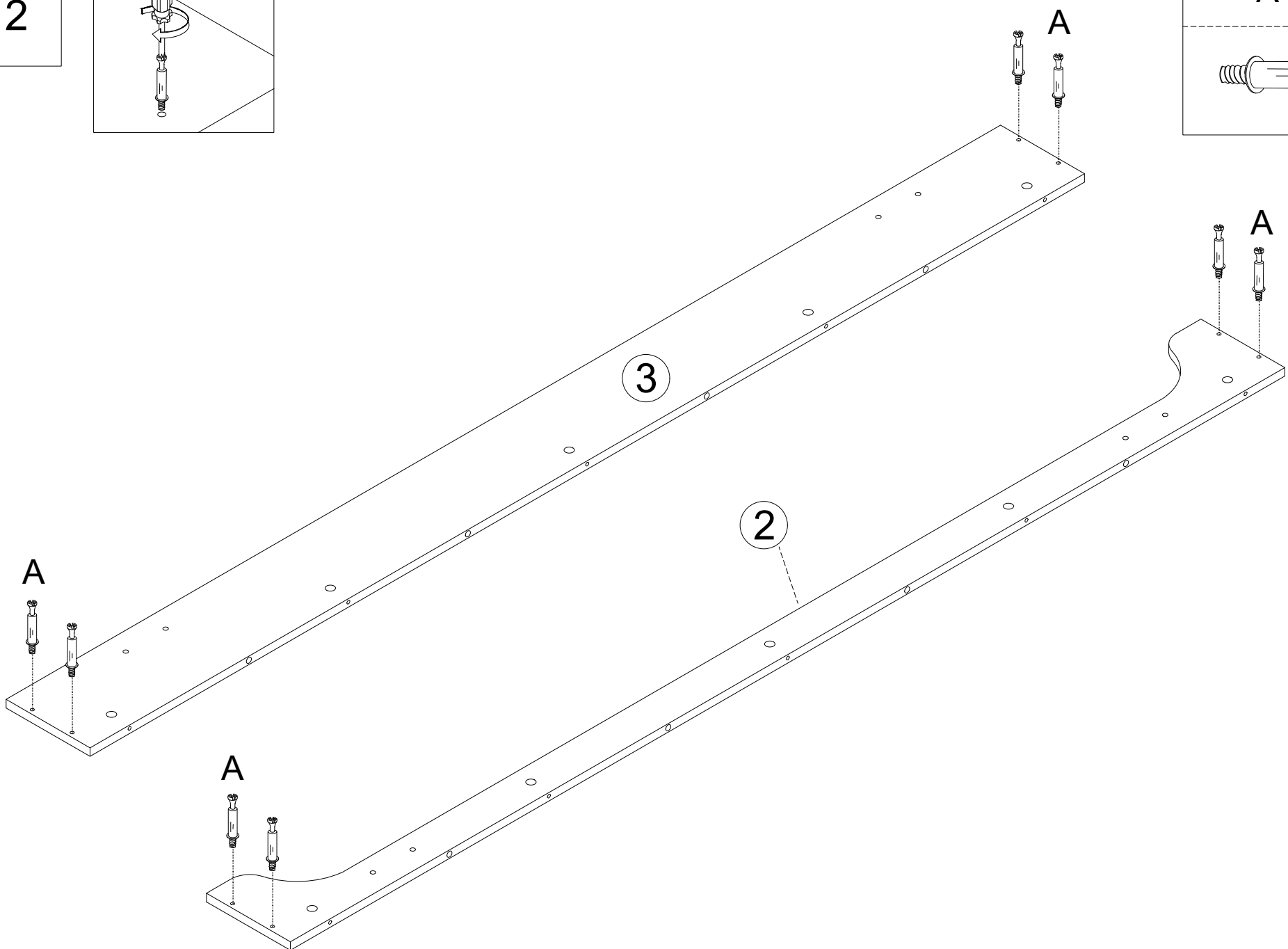
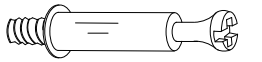

3

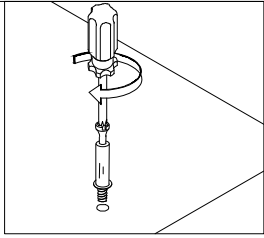

A x16

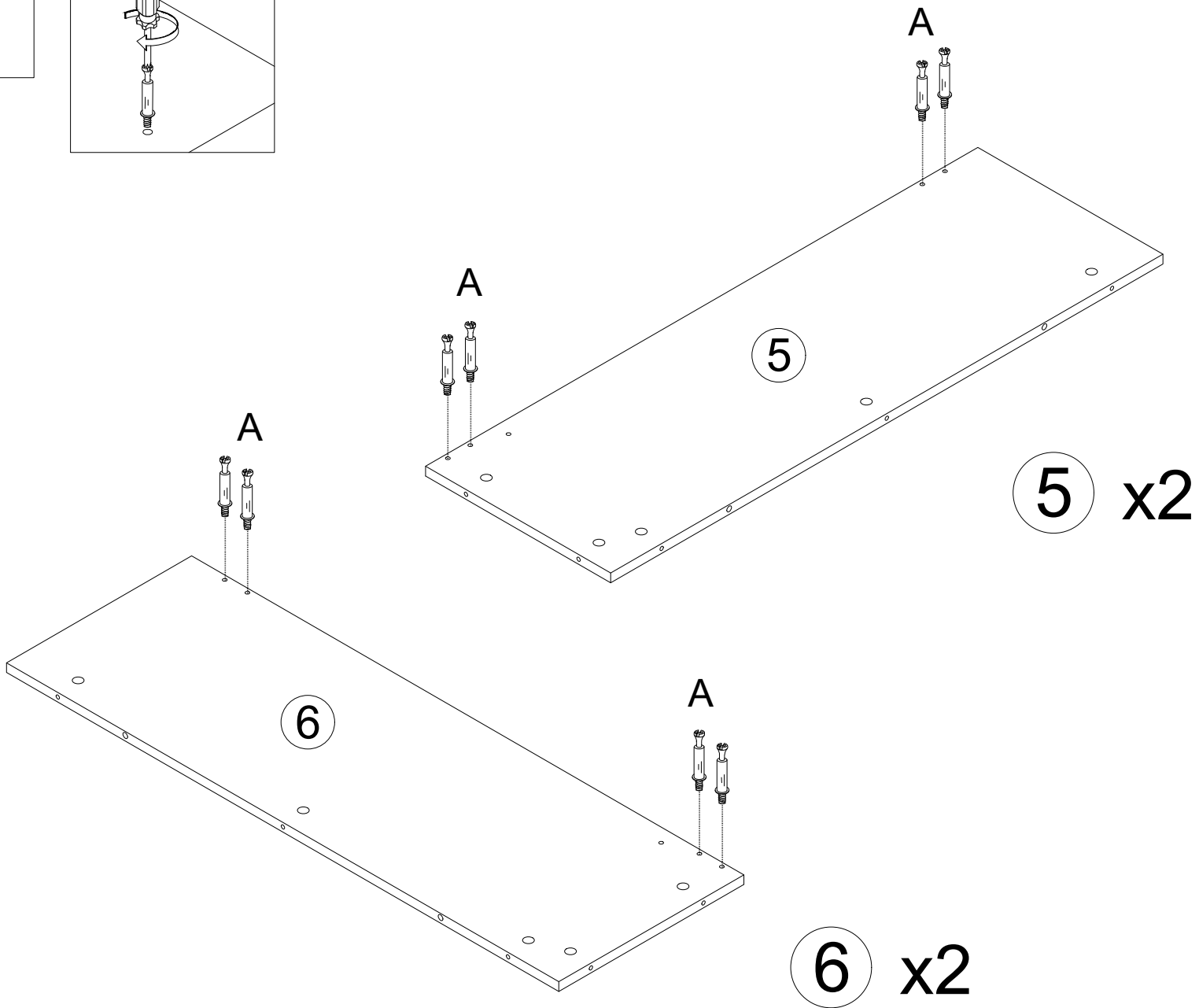
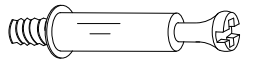

4

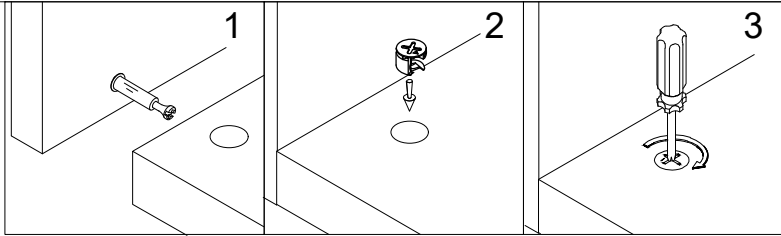

B x16

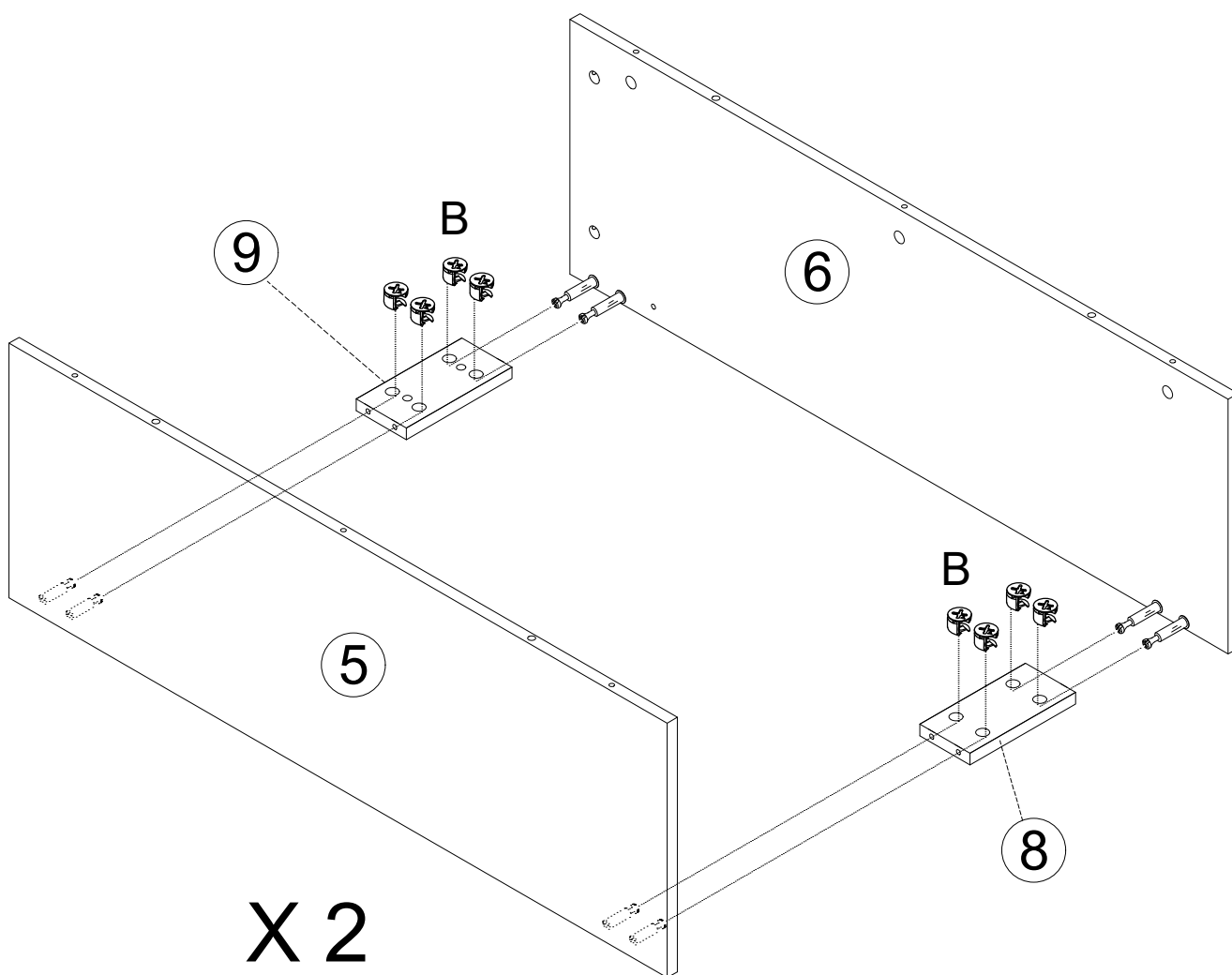

5

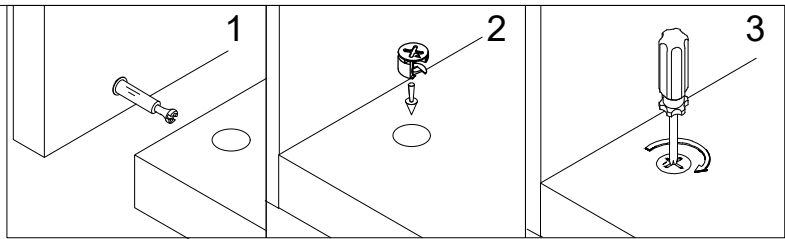

B x 12



D x 8

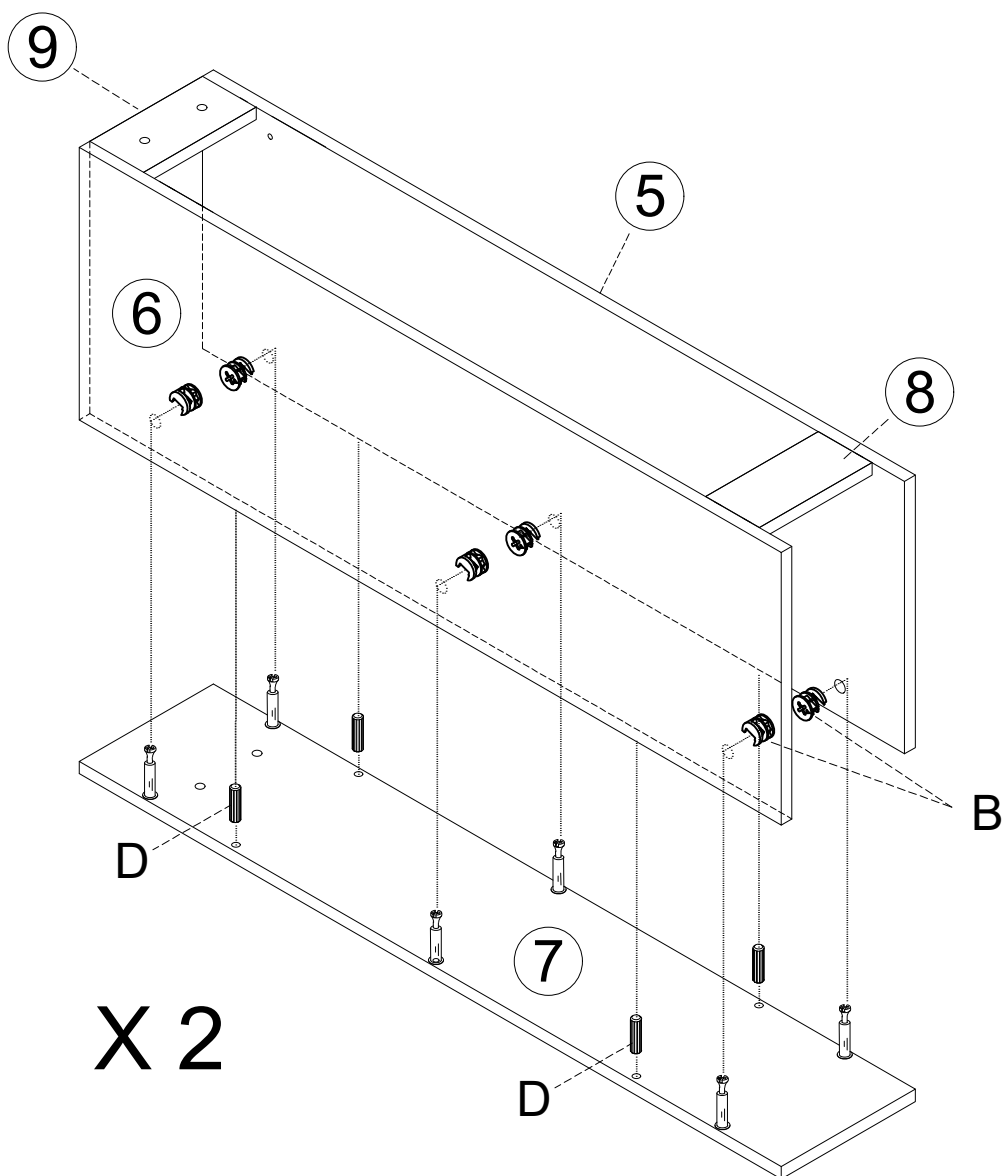
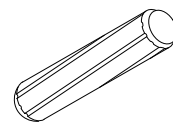

6

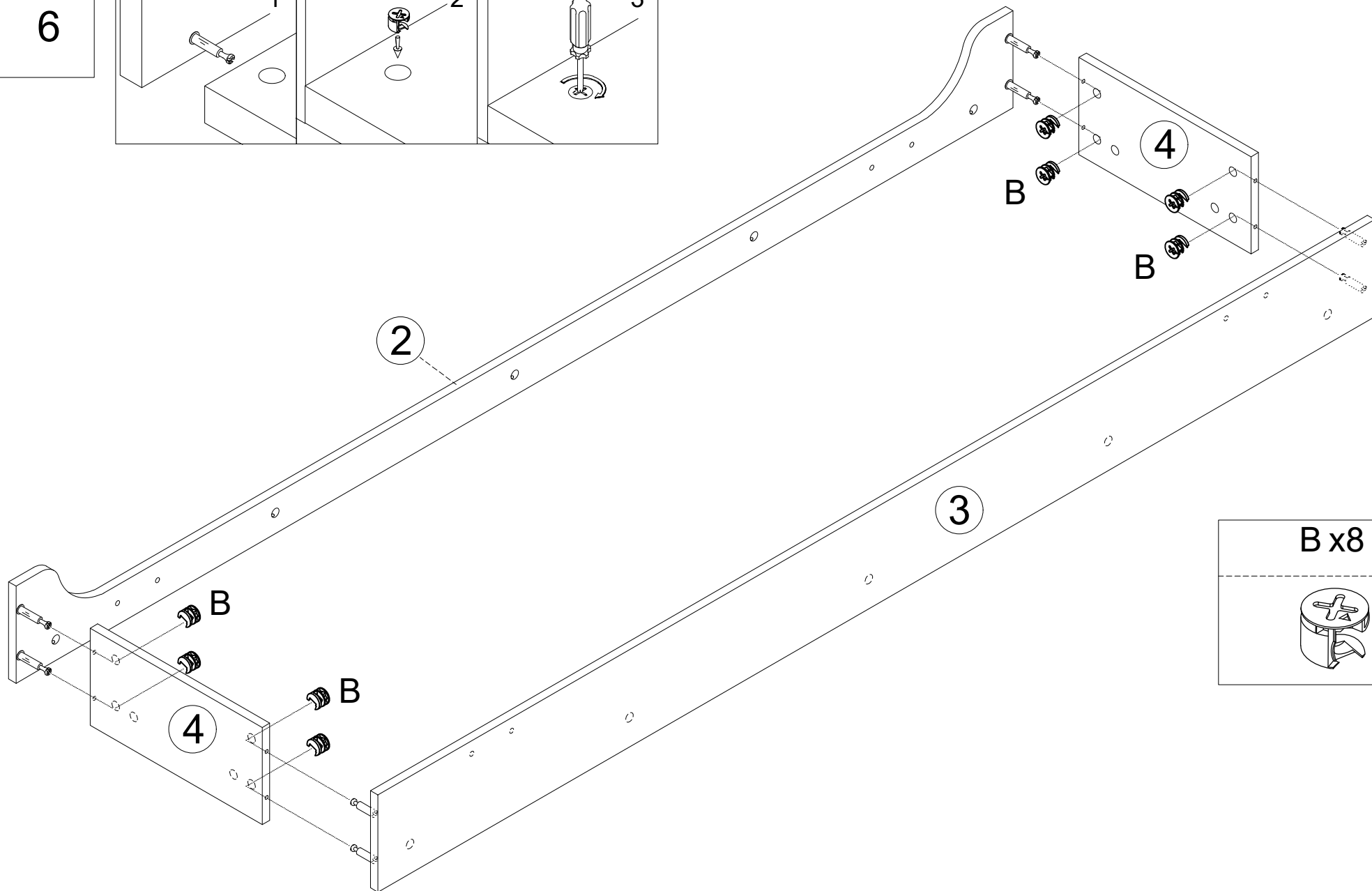
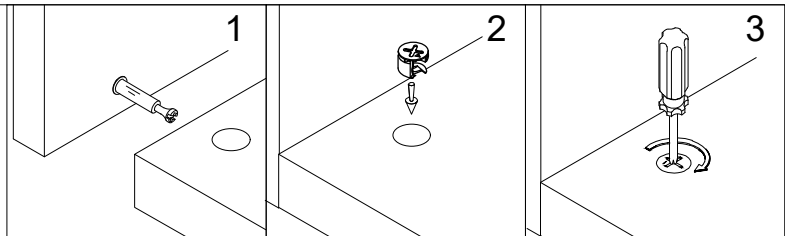

B x 8



7

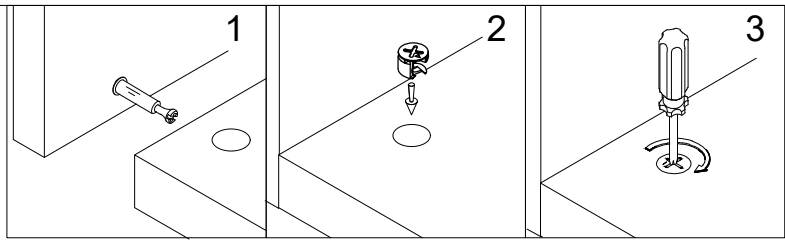

B x 14

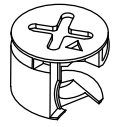

D x 8

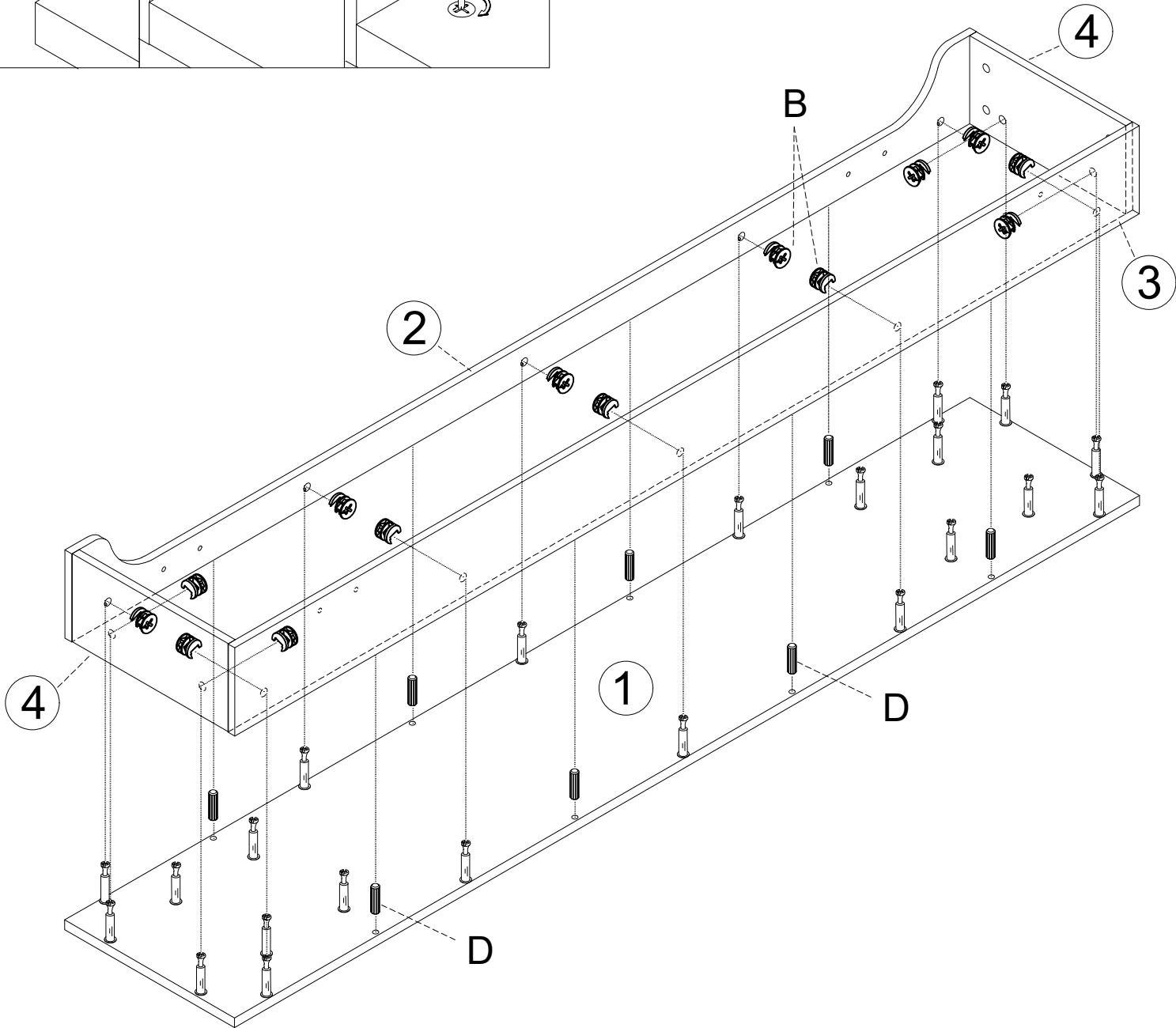
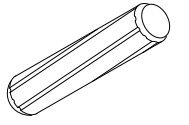

8

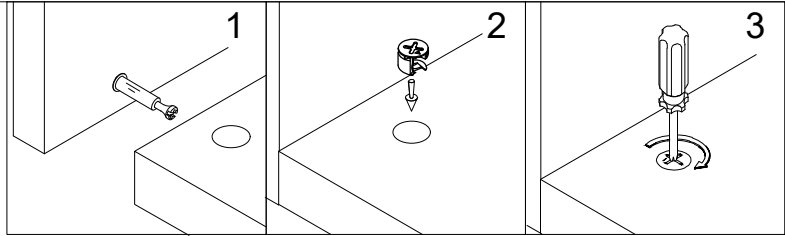

B x 8

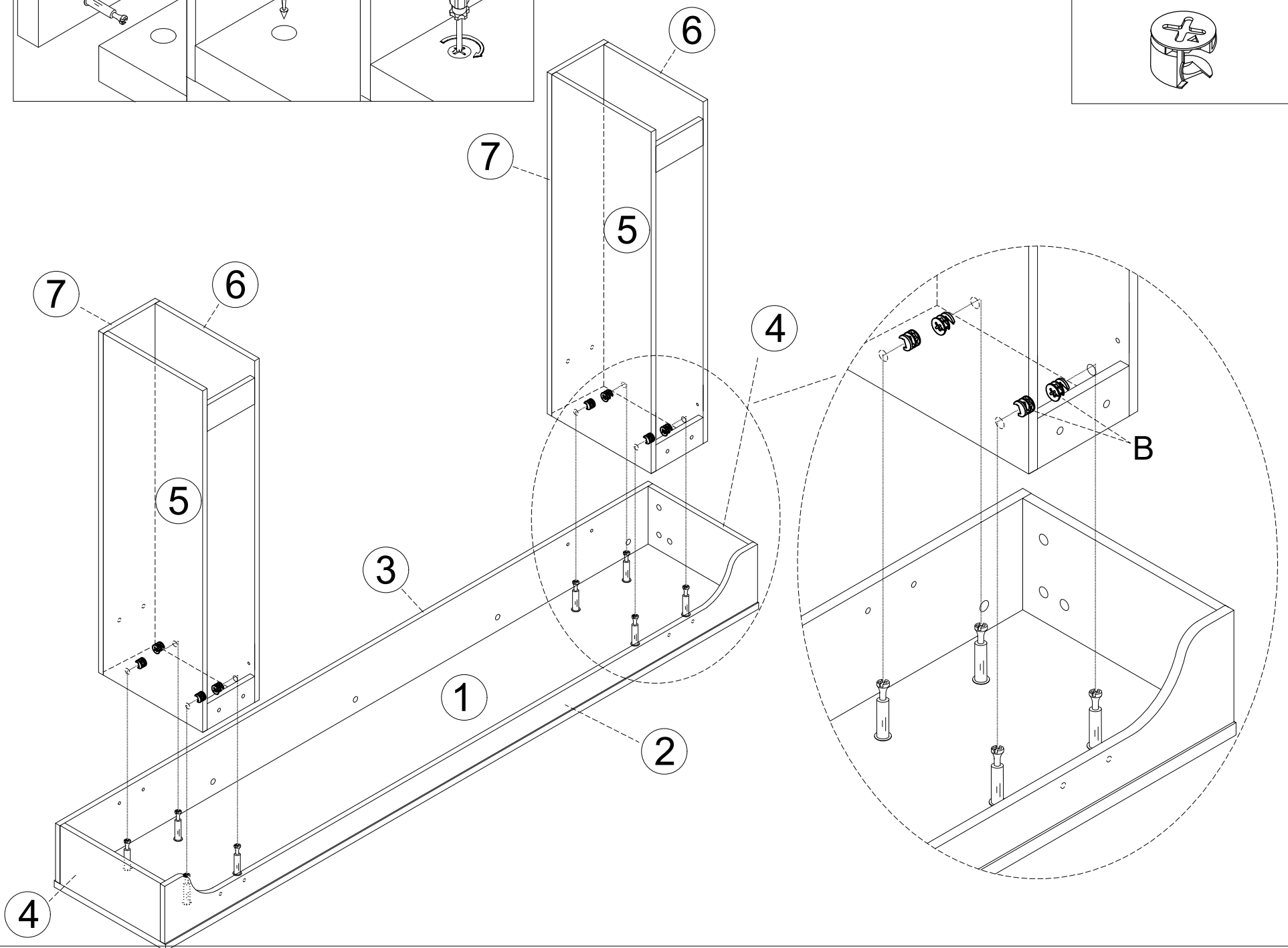

9

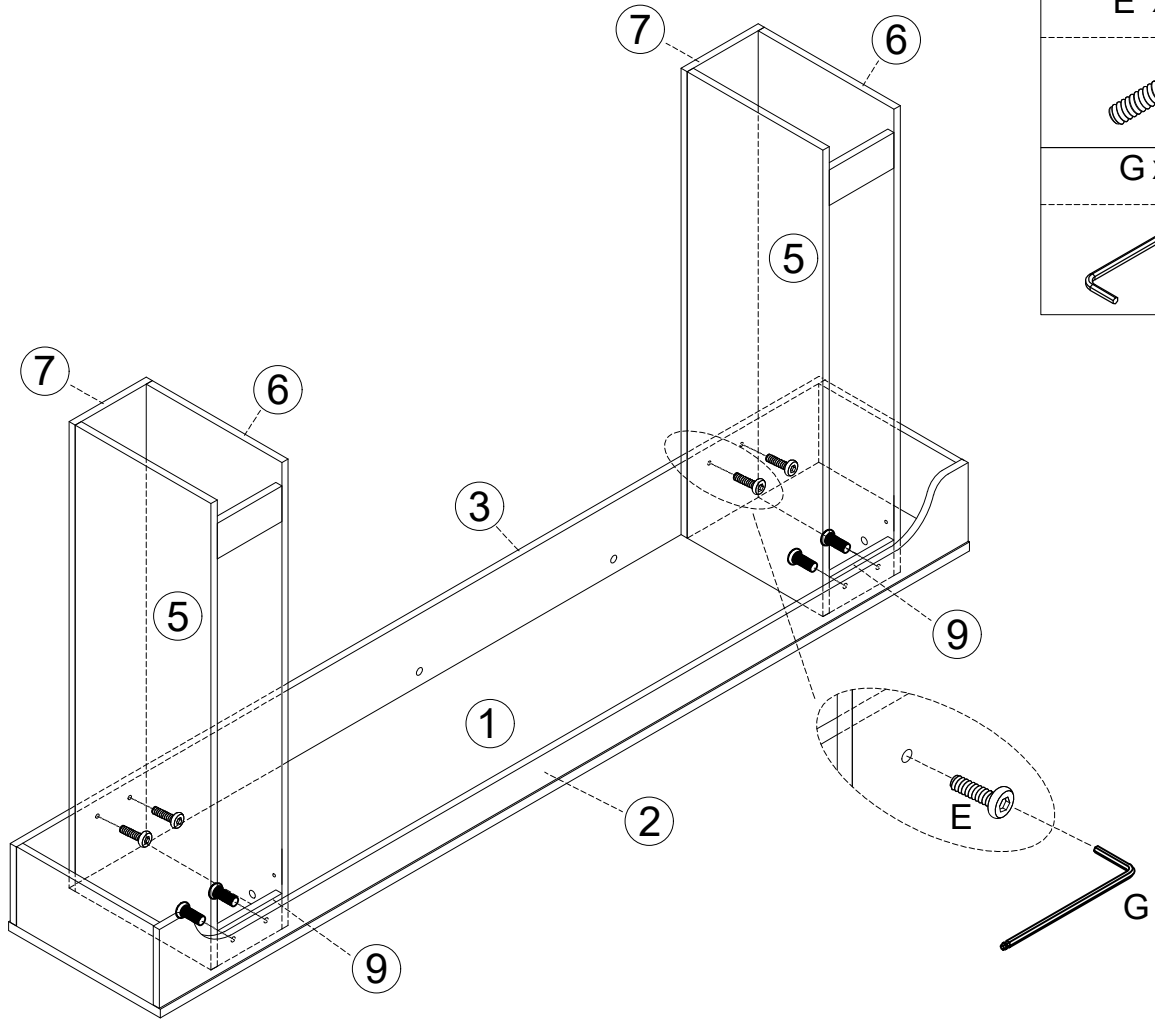

E x8



G x1

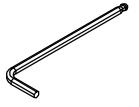

10

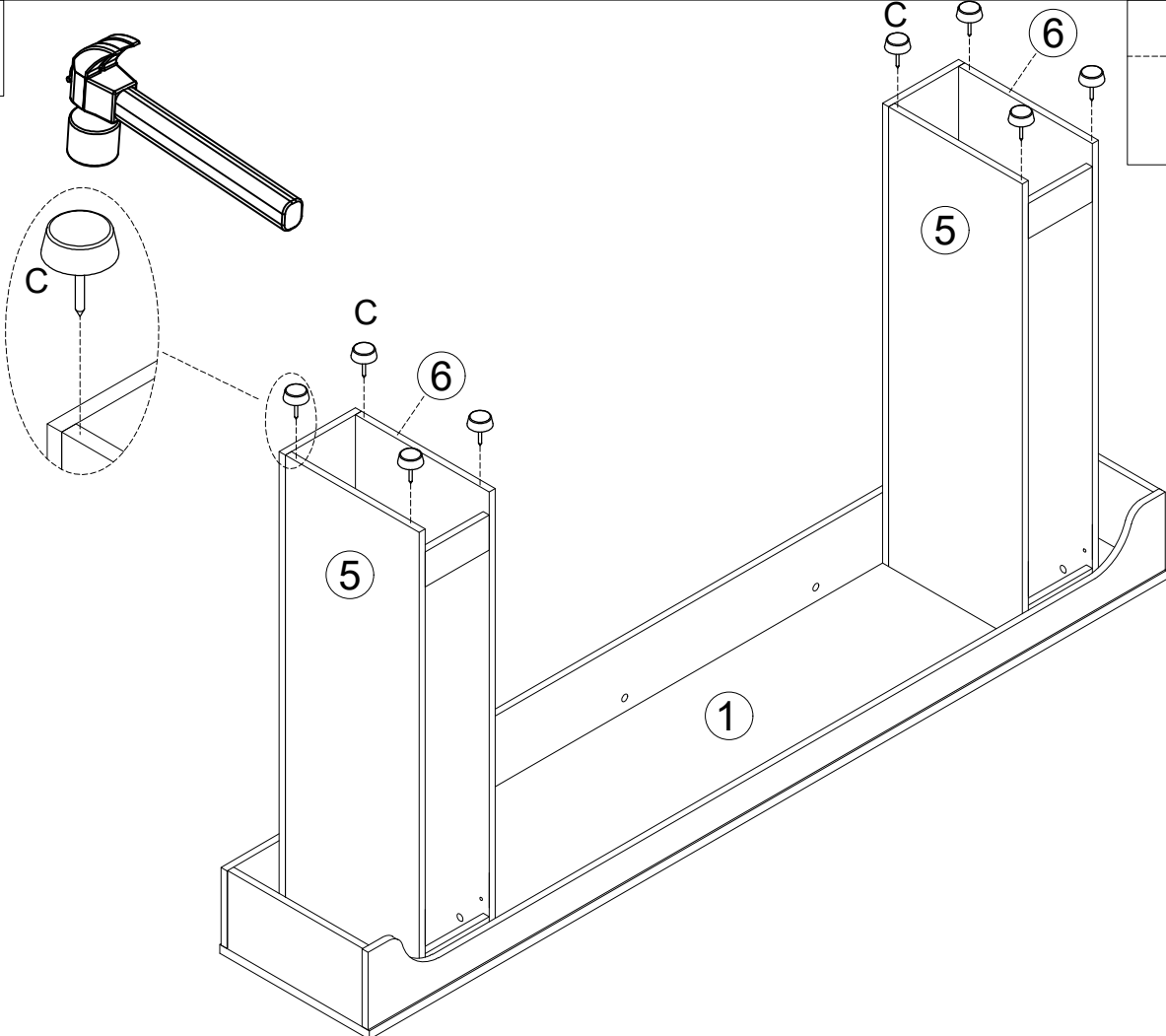

C x8

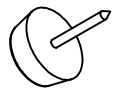

11

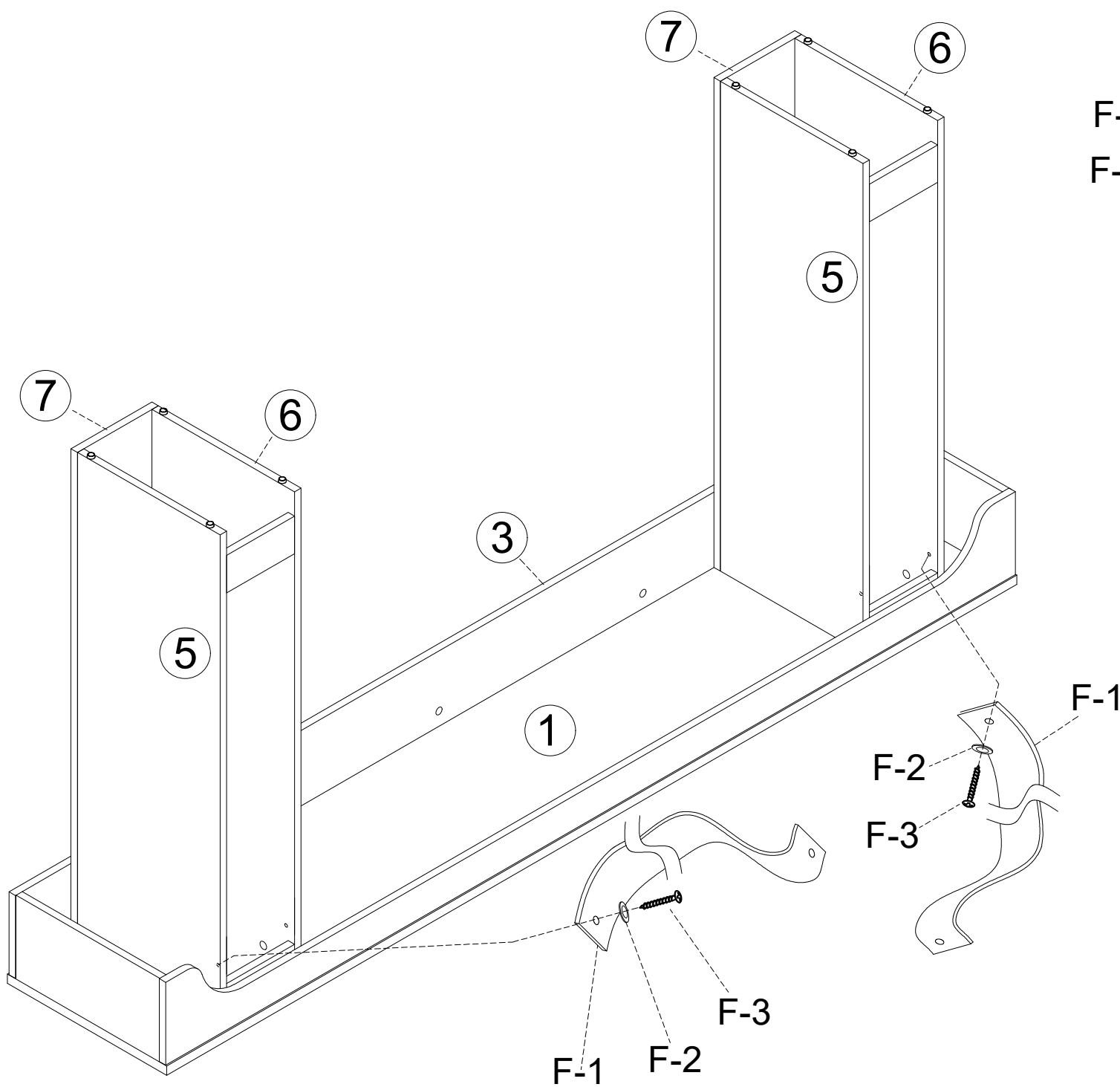

12

