

PRODUCT CARE HANDBOOK

a guide to protect your product

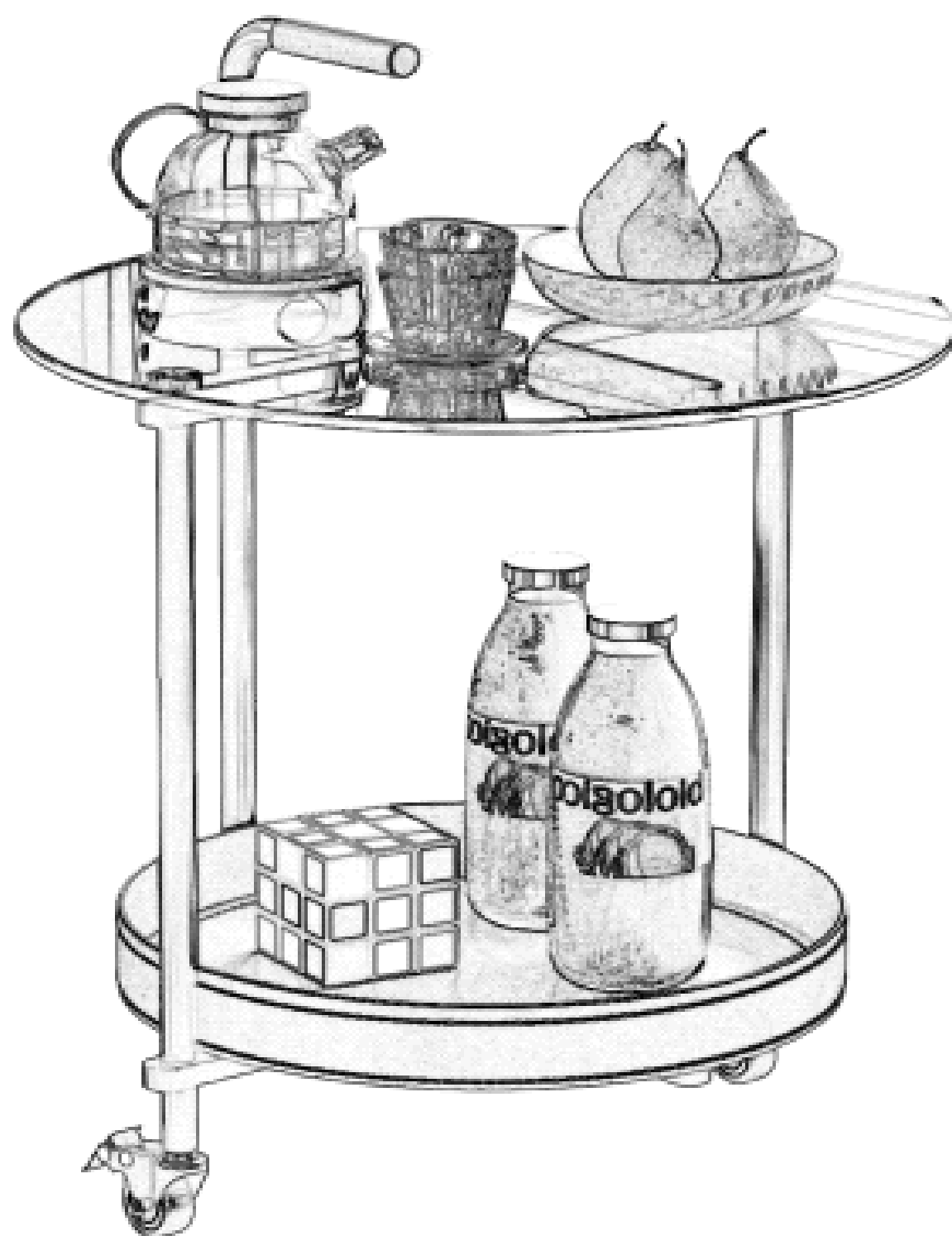

866-504-7728



support@guyii.com

www.guyii.com

Thank you for purchasing this product. Please read these instructions fully before starting assembly, then follow the simple step by step guide.

TOP TIPS BEFORE YOU START!

1. Please check that all parts & hardware are present before you start the assembly of your furniture. Do not destroy any of the packaging until you are certain that you have all the necessary parts for assembly.
2. To ensure a smooth installation, we recommend that before you commence each step of the assembly, please identify all the parts required for that step.
3. We recommend that where possible, all items are assembled near to the area in which they will be placed in use, to avoid moving the product unnecessarily once assembled.
4. For the protection of your furniture, particularly items of high gloss finish, we recommend that the product is placed on a protected surface during assembly to prevent any damage.
5. During assembly, please take care not to over-tighten any fittings, as this may damage the product.
6. Keep children and animals away from the work area. Small parts could cause choking if swallowed.

Tools Required For Assembly

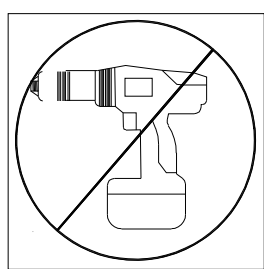

DO NOT USE POWER TOOLS TO ASSEMBLE THIS PRODUCT. USE OF POWER TOOLS WILL INVALIDATE ANY CLAIM AND MAY DAMAGE THIS PRODUCT .

Rubber Hammer

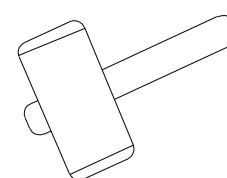

Tape Measure

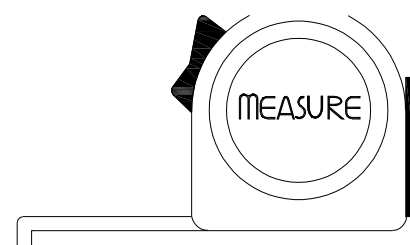

Self-provided universal tool diagram:

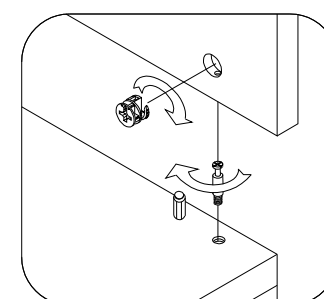
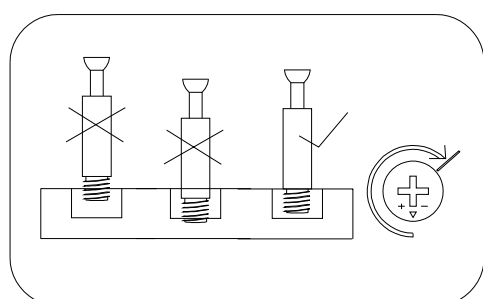
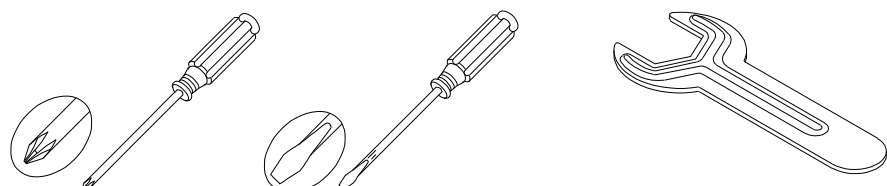

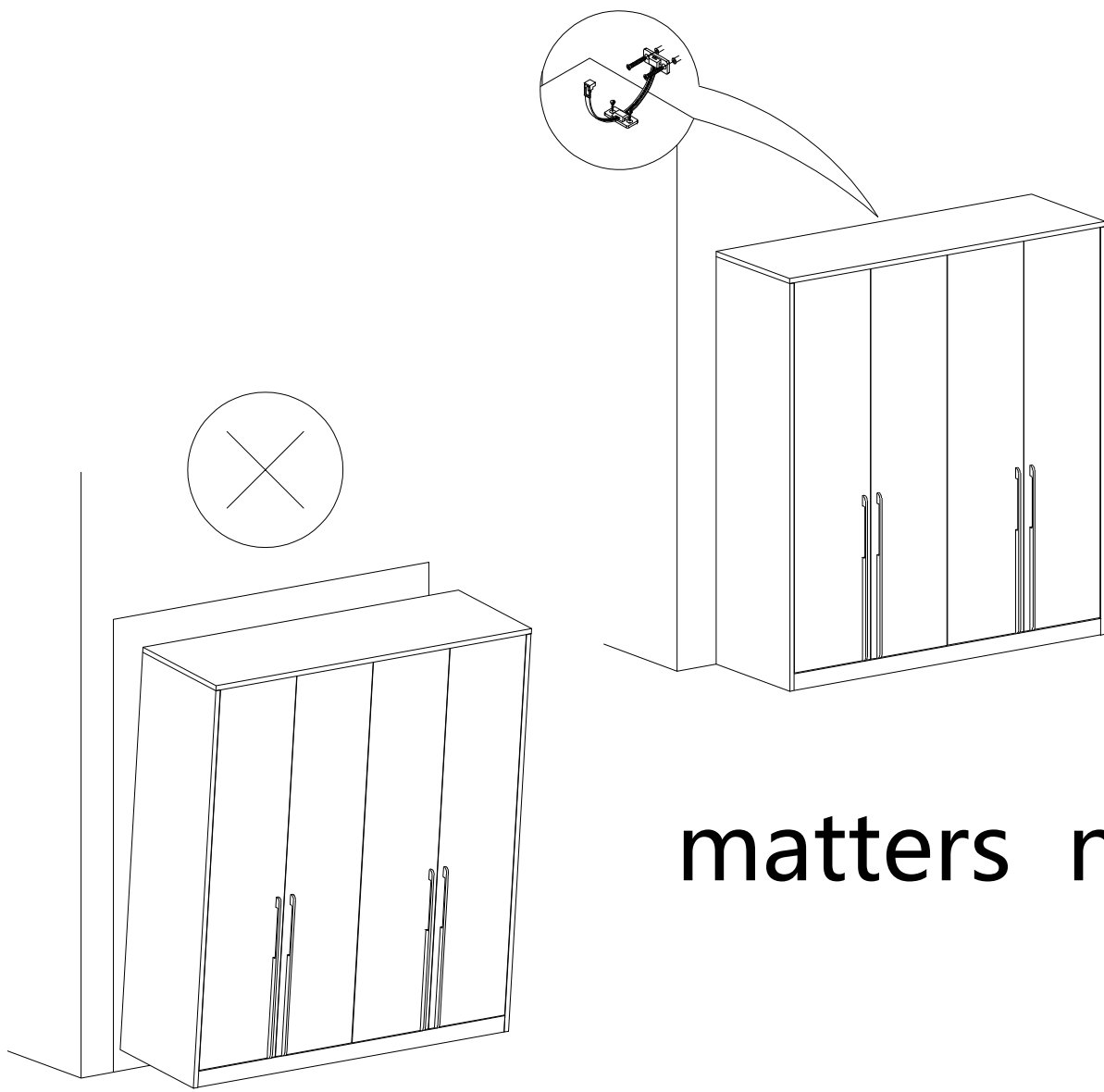



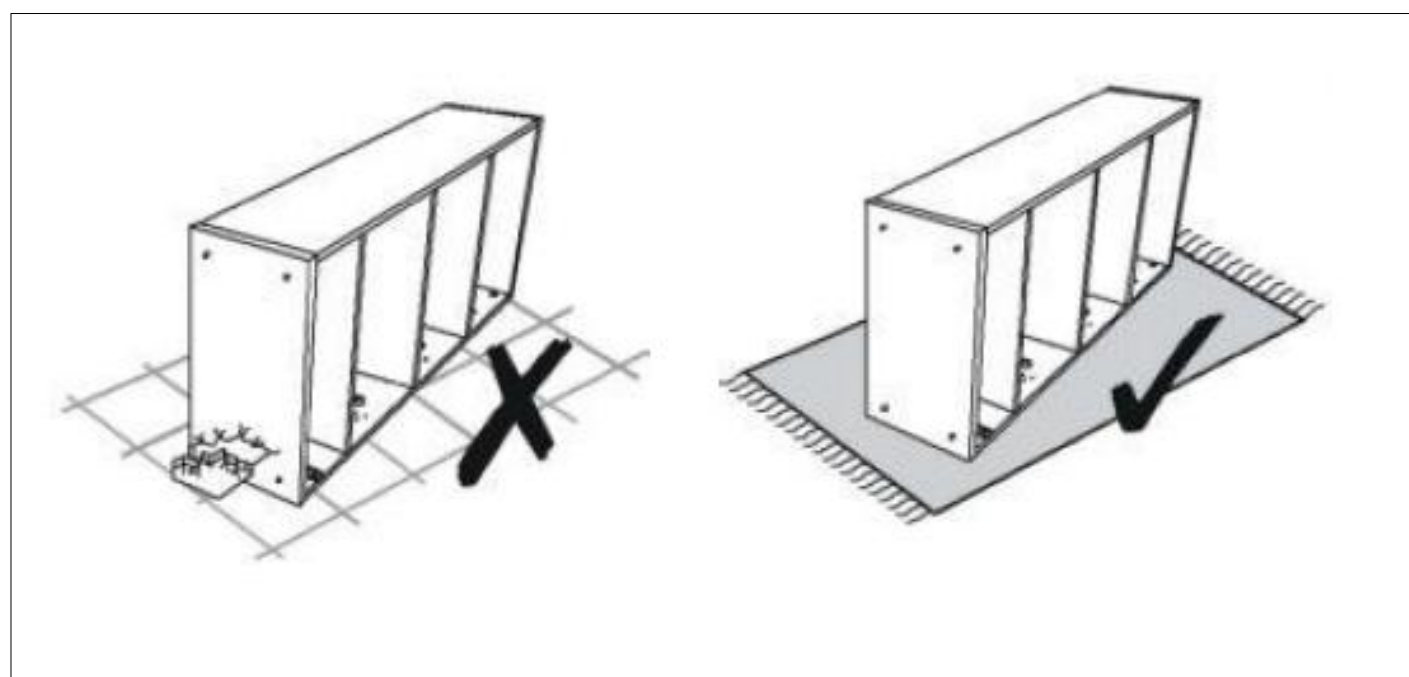
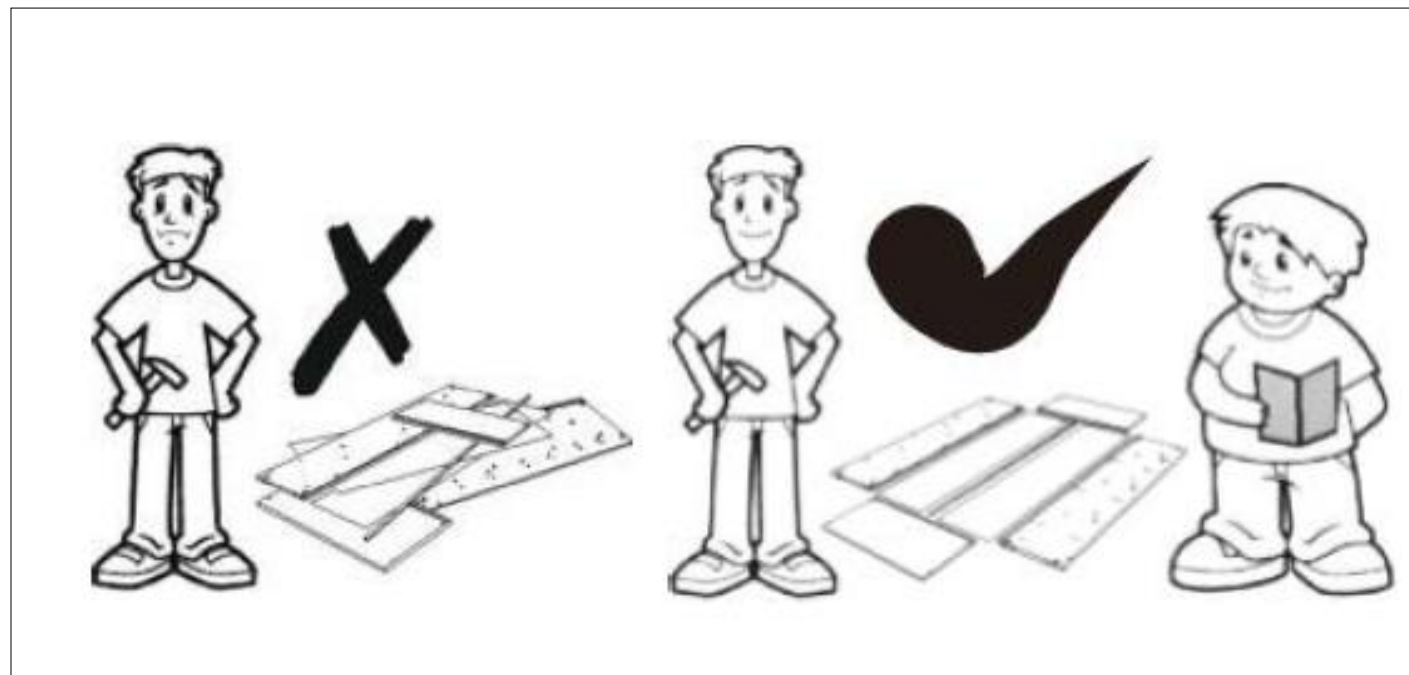

matters needing attention



GY1964HW - Side Table Assembly Hardware

<p>H1266(A)</p>  <p>Through-thread Rod M6*60</p> <p>4PCS</p>	<p>H1263(B)</p>  <p>Through-thread Rod M6*30</p> <p>3PCS</p>	<p>H6093(C)</p>  <p>Double-sided Adhesive Discs Φ20</p> <p>4PCS</p>	<p>H2619(D)</p>  <p>Swivel Casters 1 in</p> <p>4PCS</p>	
---	---	--	--	--

GY1964HW - Side Table Assembly Parts

B01*1 Handle	B03*2 Cross Connectors	B05*1 Storage Box	B07*1 Aluminum Washer
B02*1 Glass Panel	B04*3 Long Connecting Rods	B06*4 Short Connecting Rods	B08*1 Decorative Ring

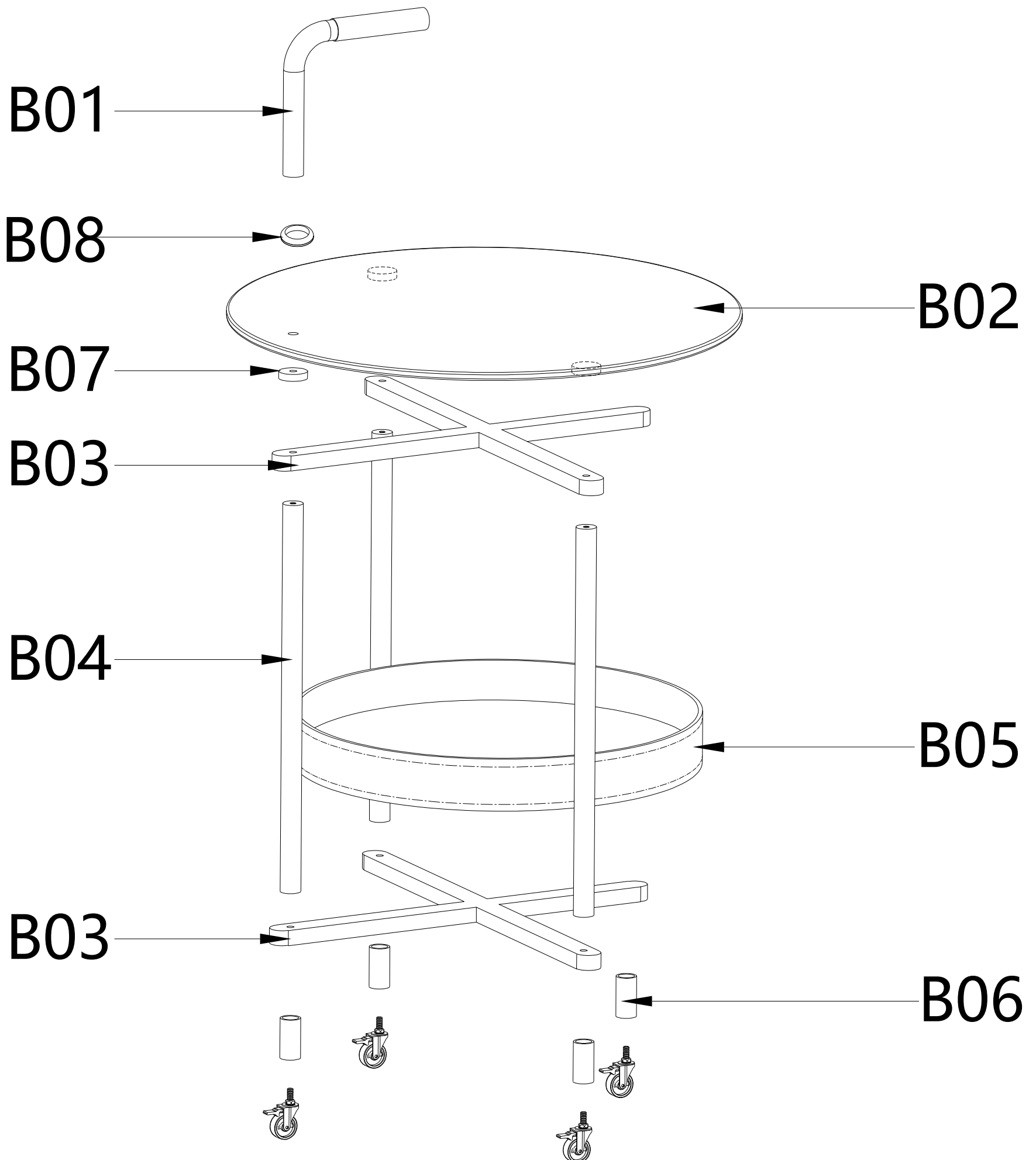

GY1964HW - Side Table Assembly Steps

Step 1

H1266(A)

H1263(B)



1PC

2PCS

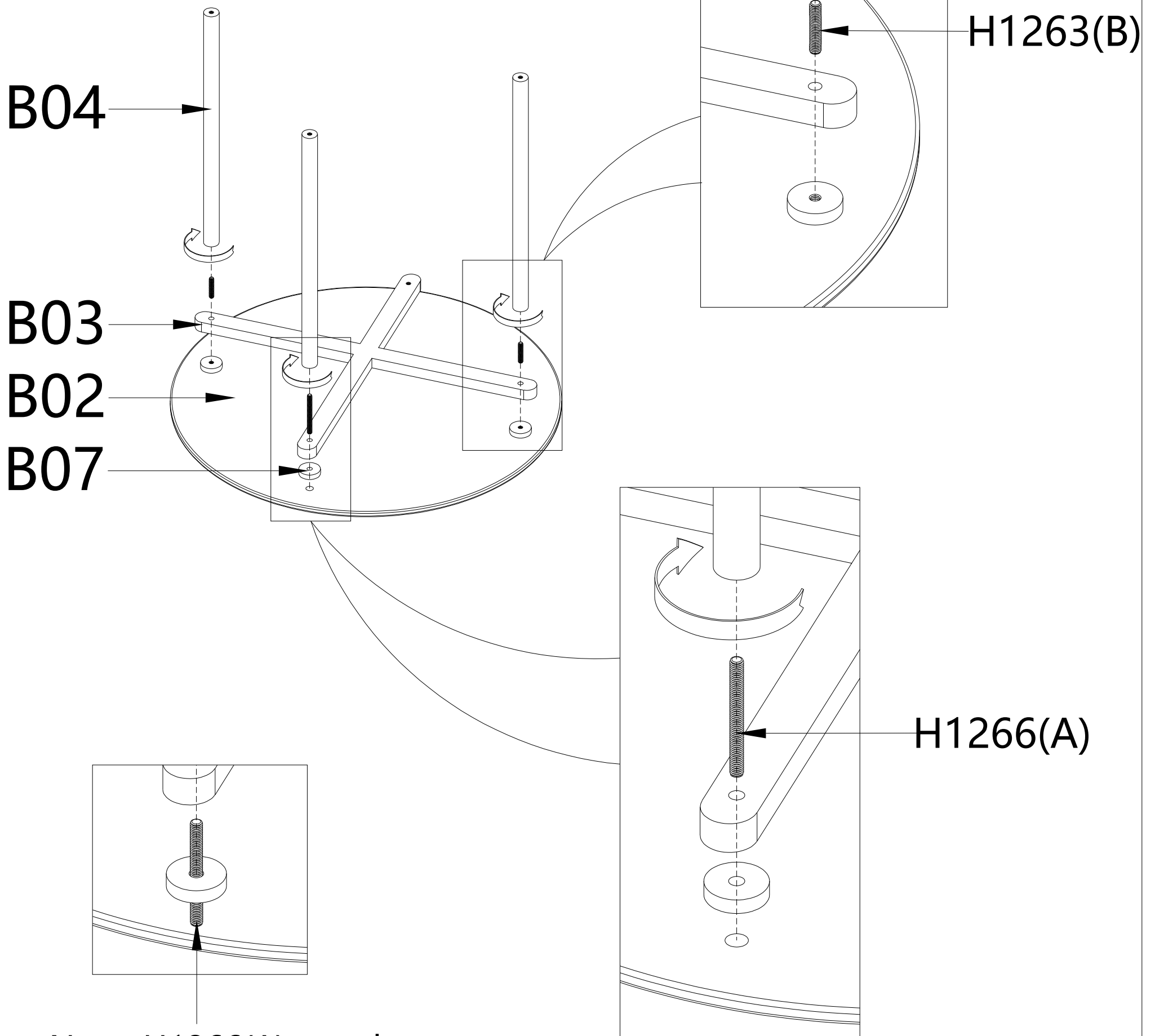

Note: H1266(A) needs to pass through the B02 glass panel, exposing the panel about 15mm.

Step 2

H1266(A)	H1263(B)
3PC	1PCS

B03

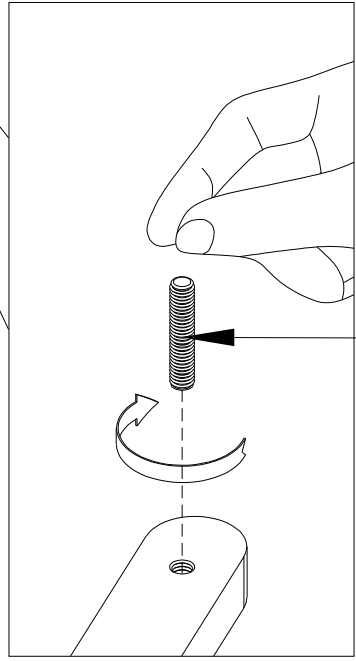
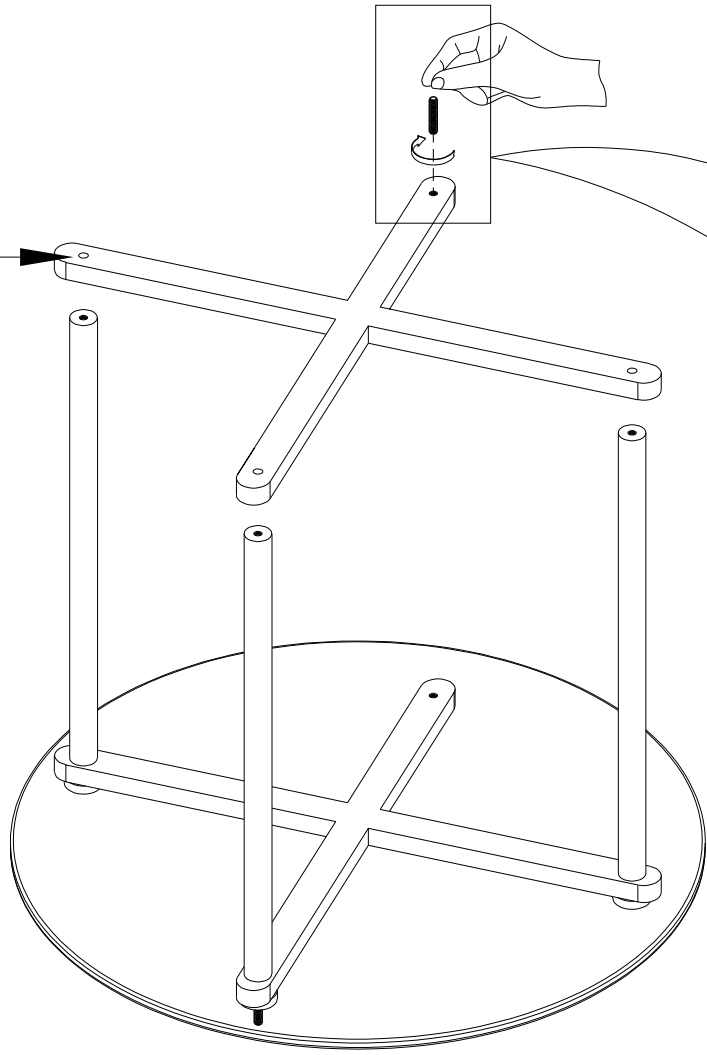

H1263(B)

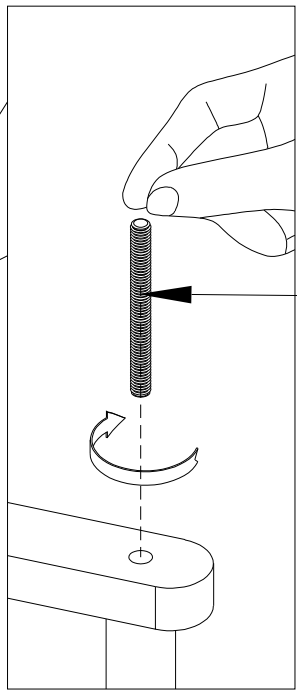
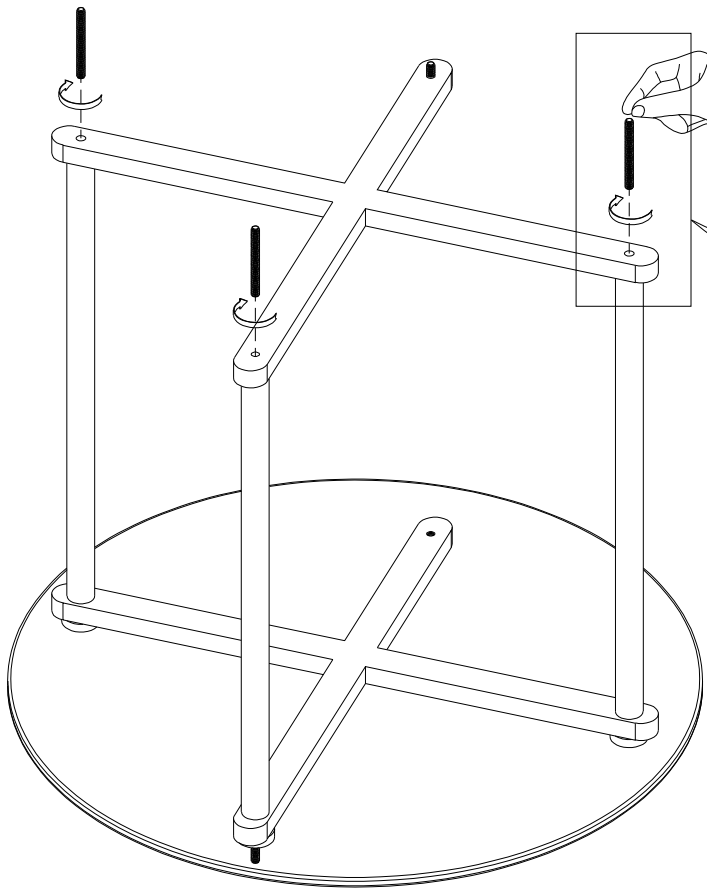

H1266(A)

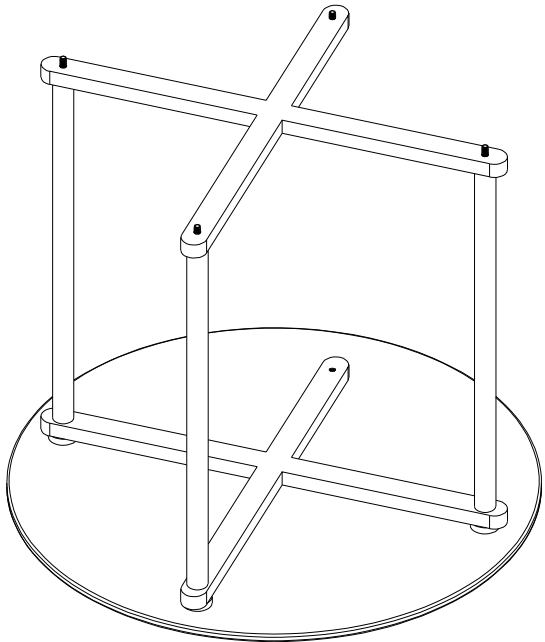

Step 3

H2619(D)



4PCS

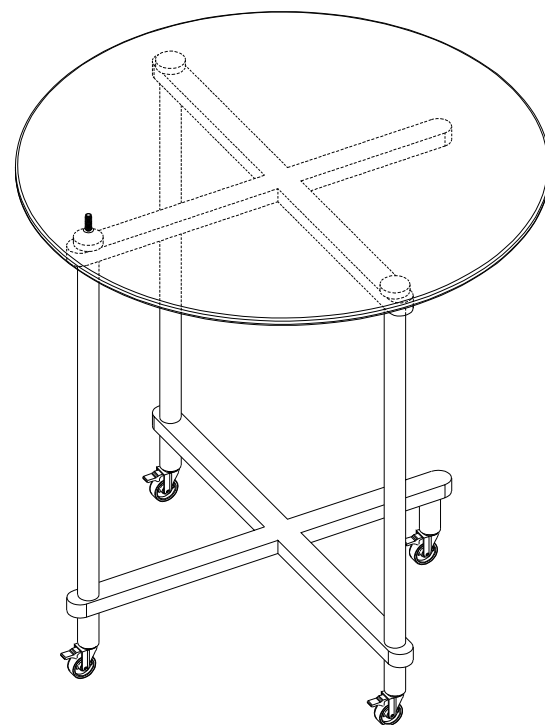
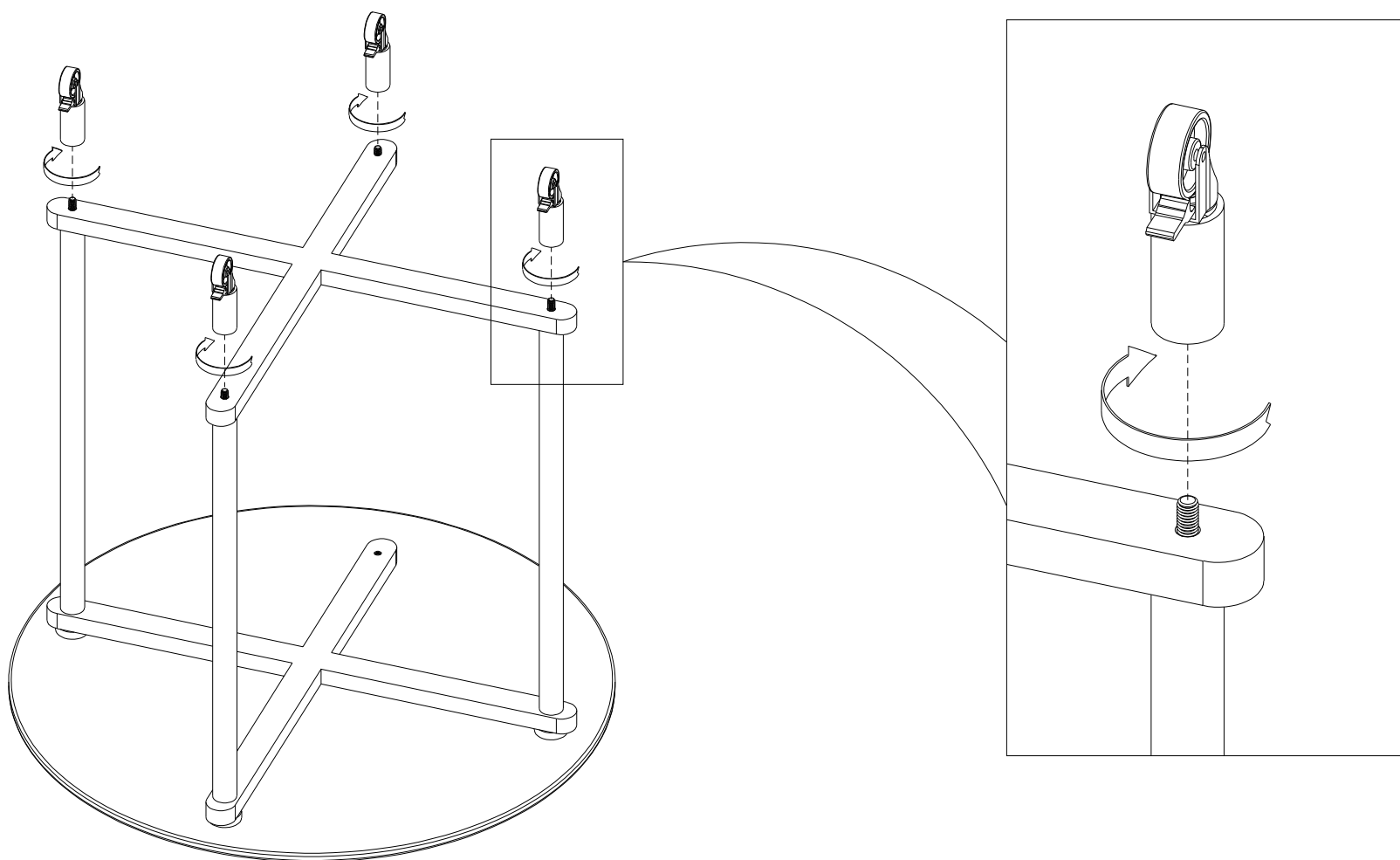
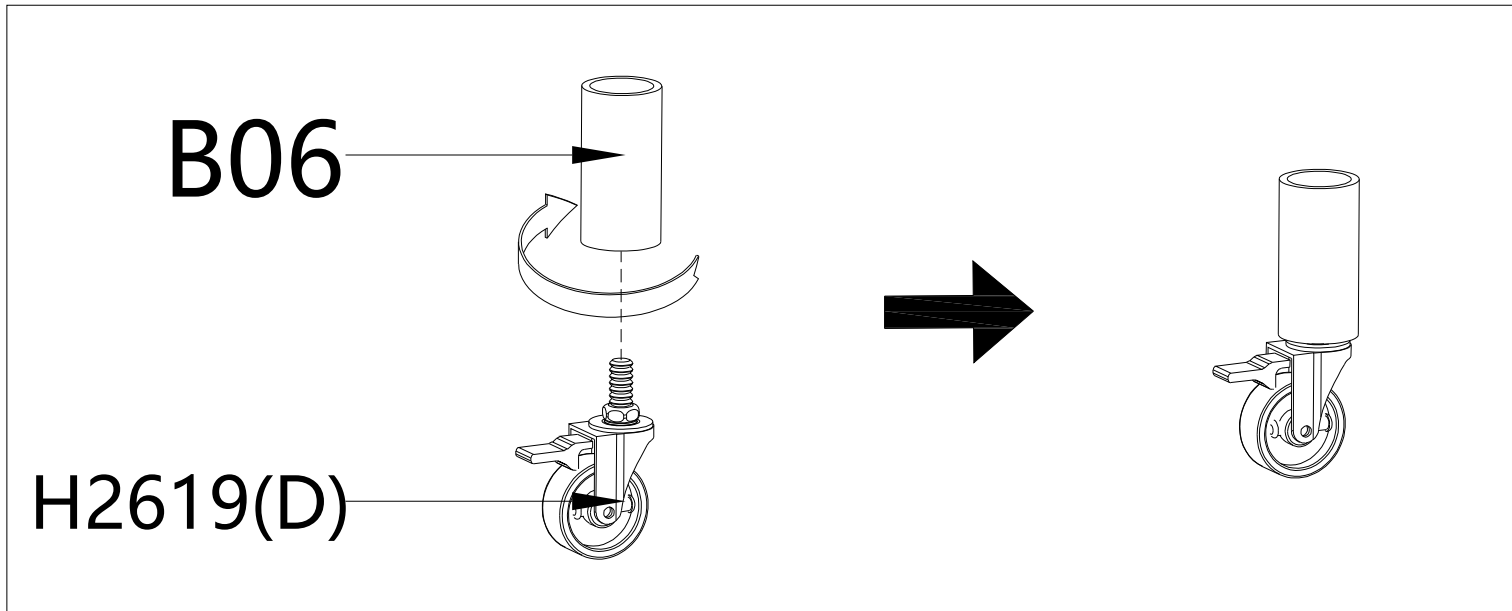

Step 4

H6093(C)

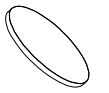

4PCS

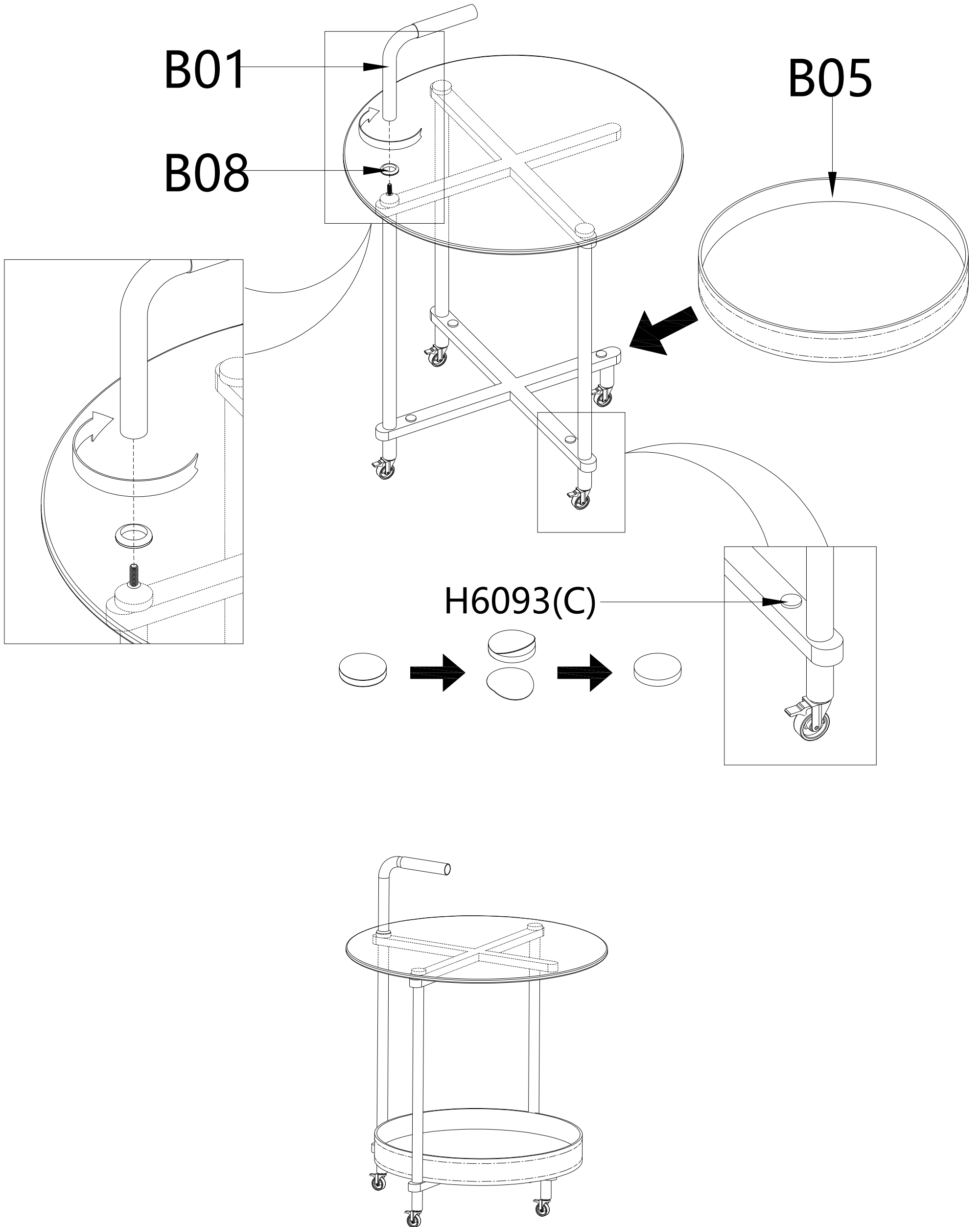

WE'RE HERE TO HELP

how to get in touch with us



866-504-7728



support@guyii.com
