

ASSEMBLY INSTRUCTIONS

INSTRUCTIONS DE MONTAGE

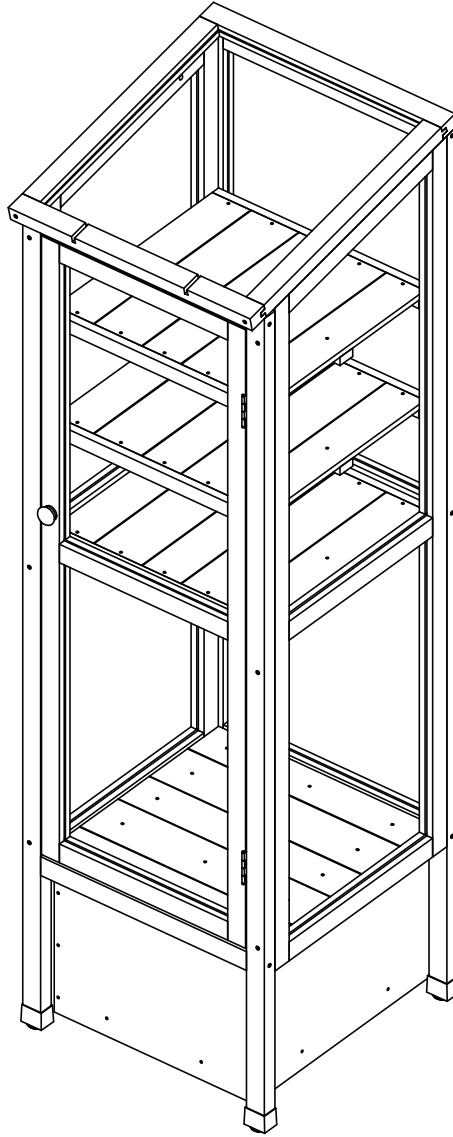

IMPORTANT NOTE:

REMARQUE IMPORTANTE:

① PLACE ALL PARTS ON A CLEAN AND SMOOTH SURFACE SUCH AS A RUG OR CARPET TO AVOID THE PARTS FROM BEING SCRATCHED.

PLACEZ TOUTES LES PIÈCES SUR UNE SURFACE PROPRE ET LISSE COMME UN TAPIS OU UN CAPET POUR ÉVITER QUE LES PIÈCES SONT ÉCARTÉES.

② BEFORE YOU BEGIN, KINDLY FOLLOW THE ASSEMBLY INSTRUCTIONS STEP BY STEP. AVANT DE COMMENCER, VEUILLEZ SUIVRE LES INSTRUCTIONS D'ASSEMBLAGE ÉTAPE PAR ÉTAPE

③ DO NOT TIGHTEN ALL SCREWS AND BOLTS UNTIL THIS ITEM IS FULLY SET-UP. NE SERREZ PAS TOUS LES VIS ET BOULONS JUSQU'À CE QUE LE CHAISE SOIT COMPLÈTEMENT INSTALLÉ.



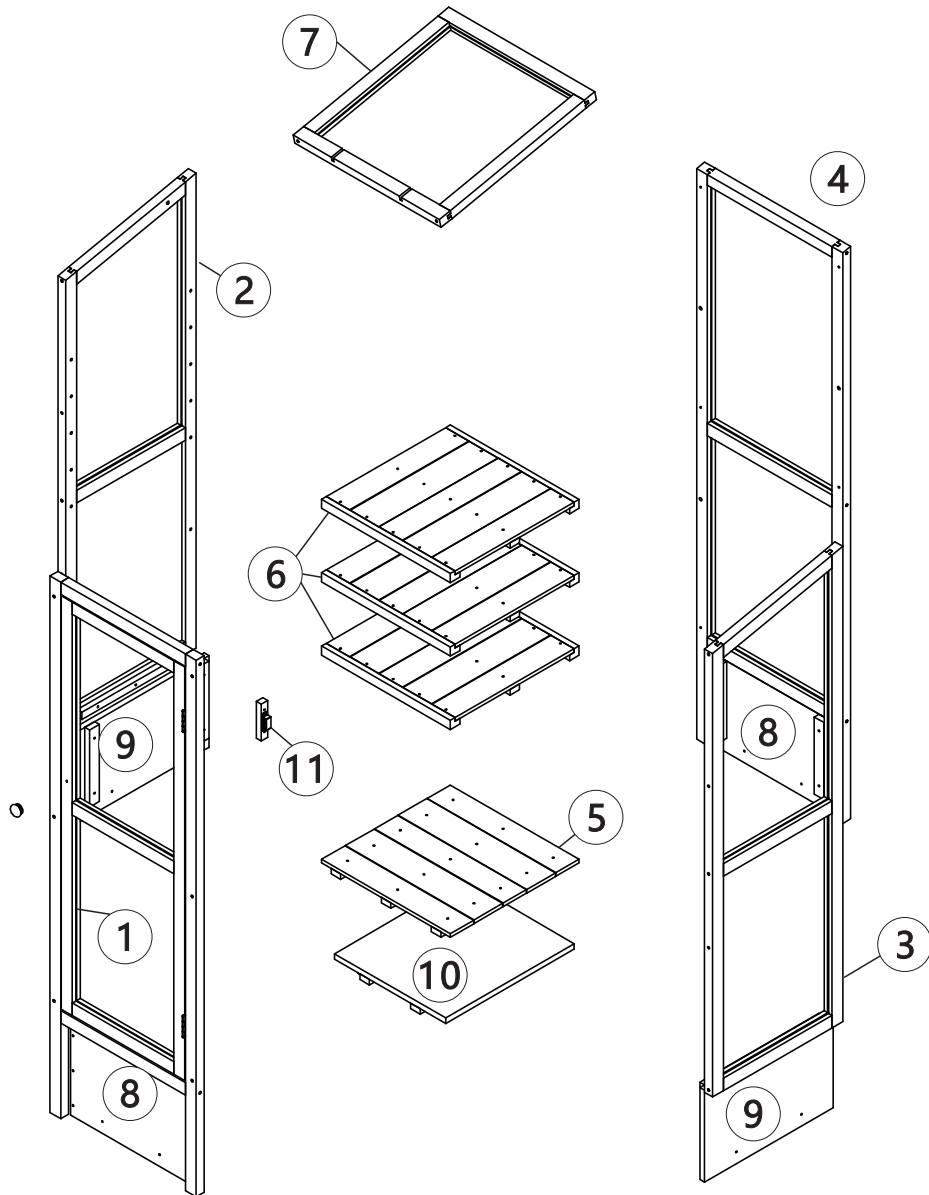



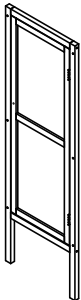
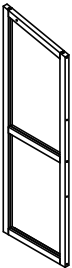
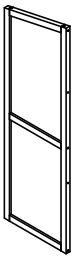
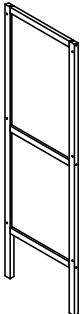
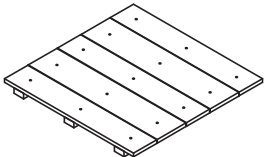
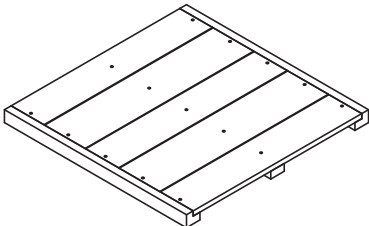
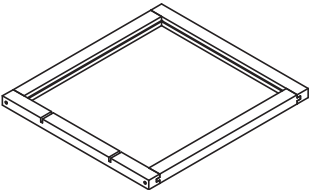
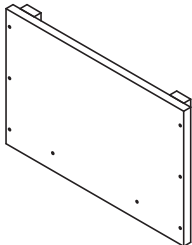
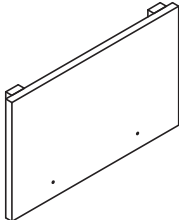
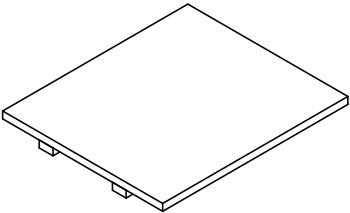
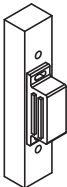





Detail View Vue détaillée

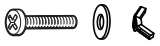

Part List
Liste des pièces

<p>1</p> 	<p>2</p> 	<p>3</p> 
<p>Front panel Panneau avant 1pc</p>	<p>Left panel Panneau de gauche 1pc</p>	<p>Right panel Panneau de droite 1pc</p>
<p>4</p> 	<p>5</p> 	<p>6</p> 
<p>Back panel Panneau arrière 1pc</p>	<p>Bottom panel Panneau inférieur 1pc</p>	<p>Shelf Étagère 3pcs</p>
<p>7</p> 	<p>8</p> 	<p>9</p> 
<p>Roof Toit 1pc</p>	<p>Front panel of drawer Panneau avant tiroir 2pcs</p>	<p>Side panel of drawer Panneau latéral du tiroir 2pcs</p>
<p>10</p> 	<p>11</p> 	
<p>Bottom panel of drawer Panneau de tiroir inférieur 1pc</p>	<p>Magnetic wooden strips Bandes de bois magnétique 1pc</p>	

Hardware List
Liste du matériel

<p>A</p>  <p>3.5*45 Ph zinc screws Vis de zinc ph 12+1pcs</p>	<p>B</p>  <p>3.0*30 Ph zinc screws Vis de zinc ph 22+1pcs</p>	<p>C</p>  <p>3.0*16 Ph zinc screws Vis de zinc ph 33+1pcs</p>	<p>D</p>  <p>Dowel Goujon 8+1pcs</p>
<p>E</p>  <p>M4*30 Ph zinc bolt Boulon de zinc ph 1+1pcs</p>	<p>F</p>  <p>Door knob Bouton de porte 1pcs</p>	<p>G</p>  <p>Laminated nail Clou laminé 12pcs</p>	<p>H</p>  <p>Metal struct Structure métallique 1pc</p>
<p>I</p>  <p>Ph zinc bolt Boulon de zinc ph 1+1pcs</p>	<p>J</p>  <p>Adjustable base Base réglable 4pcs</p>	<p>K</p>  <p>Wheel Roue 4pcs</p>	<p>L</p>  <p>Angle steel Cornière en acier 2pcs</p>
<p>M</p> 			
<p>Ground nail Clou de sol 2pcs</p>			

**ASSEMBLY TOOLS REQUIRED(NOTINCLUDED)
OUTILS D'ASSEMBLAGE REQUIS (NON INCLUS)**

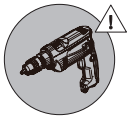

**PLEASE BE CAREFUL DO NOT DAMAGE THE HOLE POSITION
WHEN YOU USE POWERTOOLS!
VEUILLEZ FAIRE ATTENTION À NE PAS ENDOMMAGER LA POSITION
DU TROU LORS DE L'UTILISATION D'OUTILS ÉLECTRIQUES!**

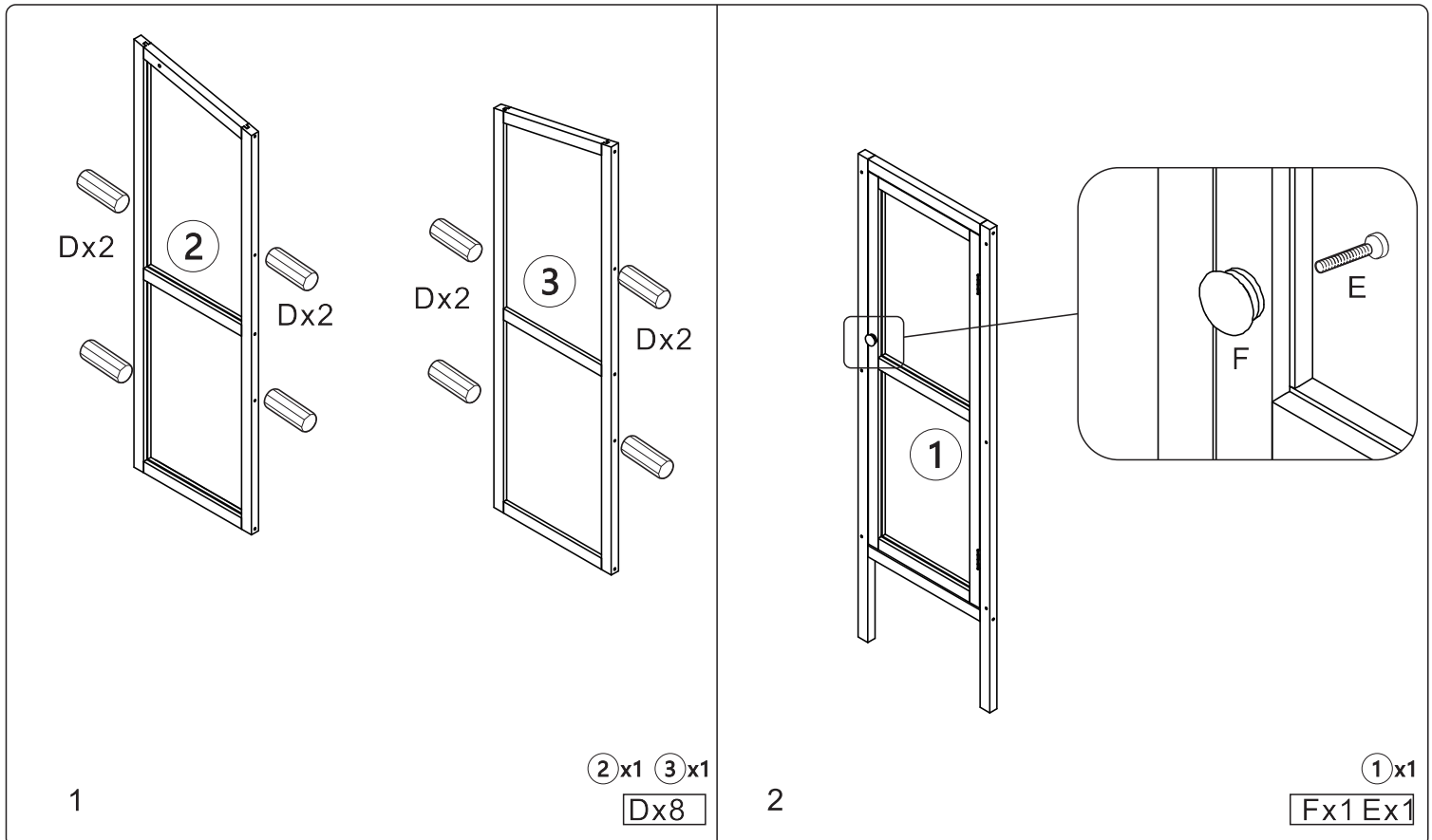

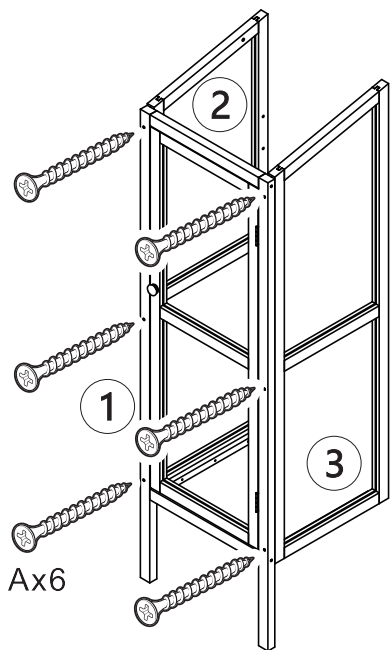

3

①x1 ②x1 ③x1
Ax6

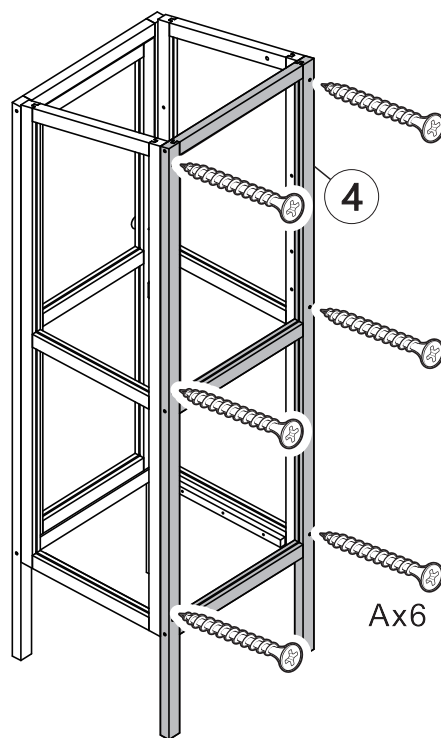

4

④x1
Ax6

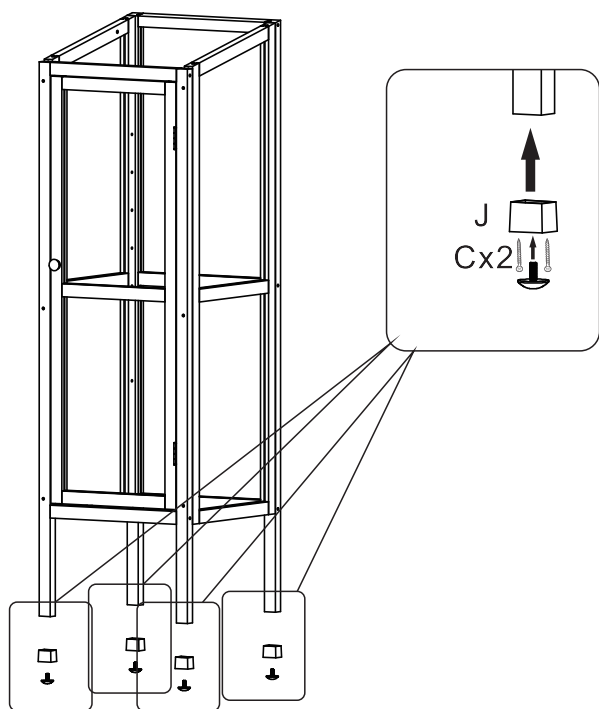

5

Cx8 Jx4

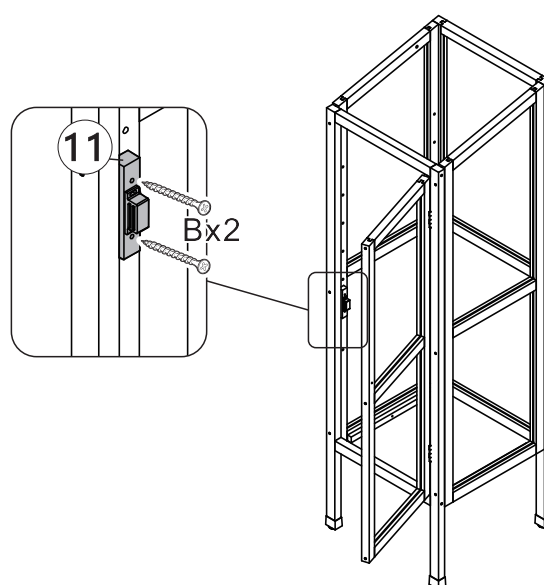

6

⑪x1
Bx2

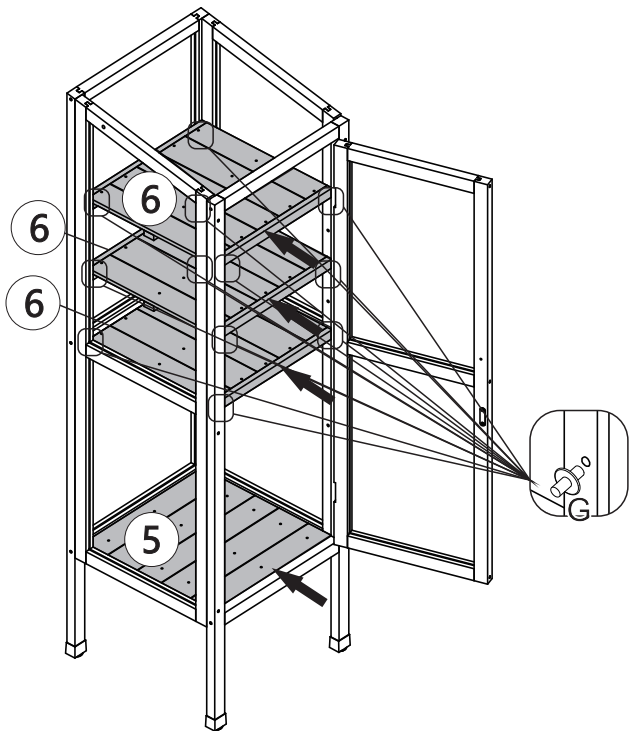

7

5)x1 6)x3
Gx12

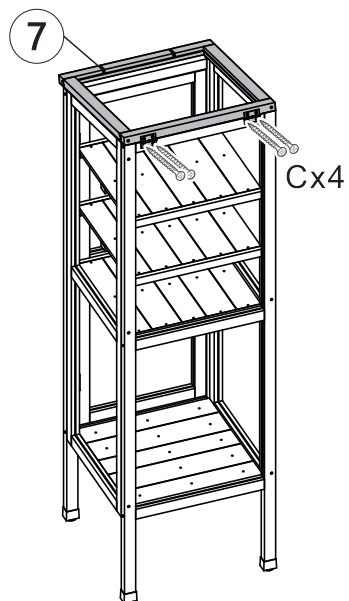

8

7)x1
Cx4

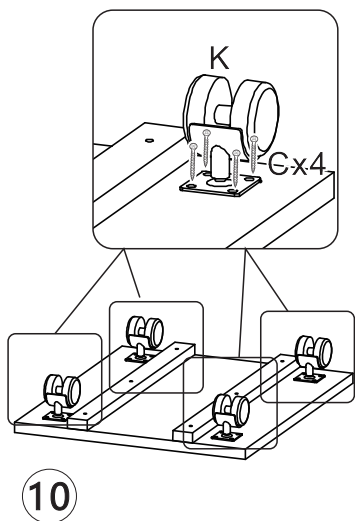

9

10)x1
Cx16 Kx4

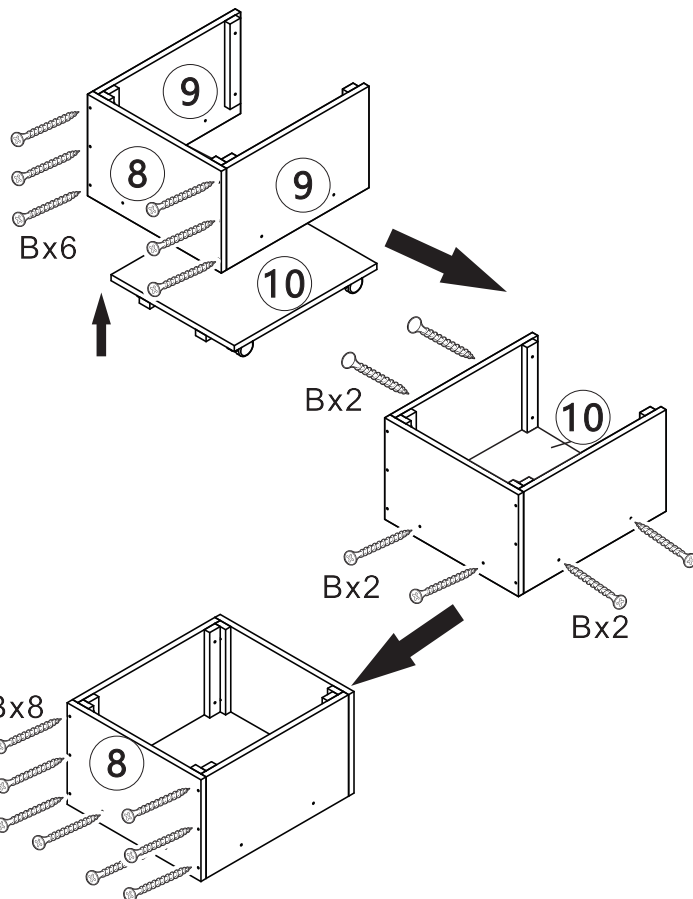

10

8)x2 9)x2 10)x1
Bx20

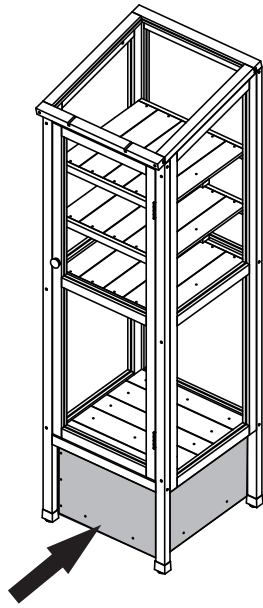

11

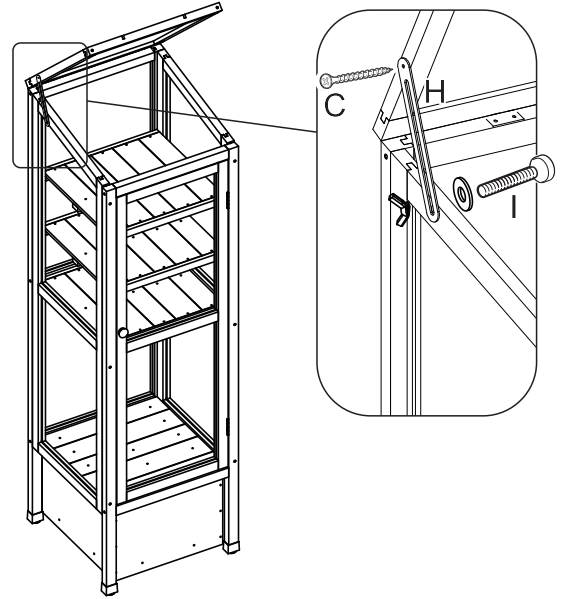

12

Cx1Hx1Ix1

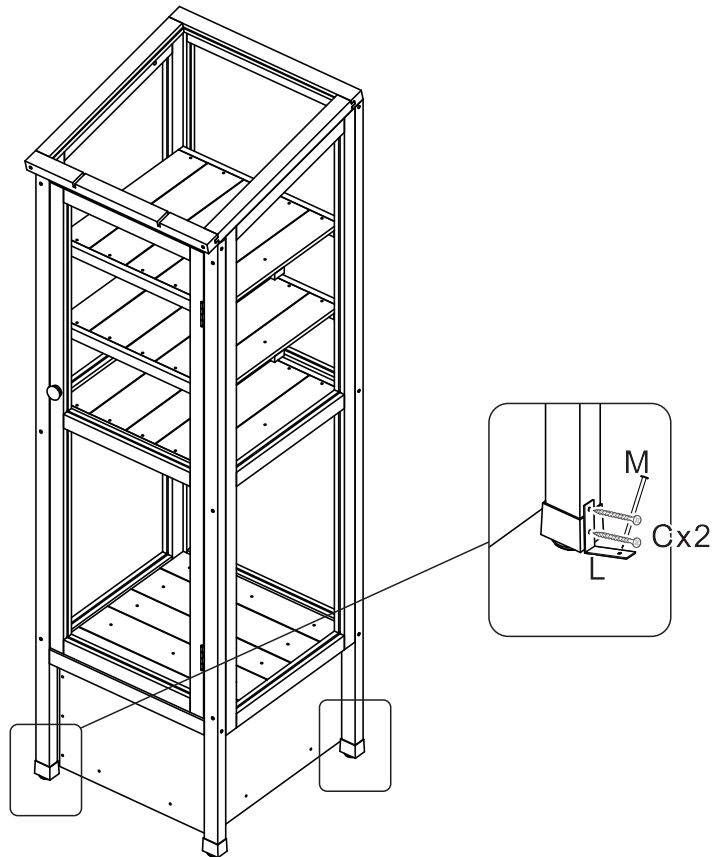

13

Cx4Lx2Mx2