



WBD2G

2-Gallon Batter Dispenser



2-Gallon Batter Dispenser



MAIN FEATURES

- Industry-approved Tomlinson® spigot*
- 304 stainless steel housing and cover
- Fits up to 2 gallons of batter
- Spigot is removable for easy cleaning
- Stainless steel drip saucer is removable for easy cleaning
- Container removes from the base
- Base features nonskid feet for safe and stable operation
- All parts are dishwasher-safe
- Built for use with waffle, pancake and crepe batters

*Tomlinson® is a registered trademark of the Meyer Company, Cleveland, OH.

SALES FEATURES

With fresh-made waffles in high demand, your operation needs an easy way to dispense waffle batter. Perfect for front- and back-of-the-house usage, this 2-gallon batter dispenser is efficient and low maintenance. A removable Tomlinson® spigot releases batter with an even pour. Built to last, the stainless steel container sits in a sturdy base and features a removable top for easy filling. A stainless steel drip saucer prevents mess.



@waringcommercial

©2020 Waring Commercial
314 Ella T. Grasso Avenue, Torrington, CT 06790
Tel. 800-492-7464 • Fax 860-496-9008

waringcommercialproducts.com

WBD2G



2-Gallon Batter Dispenser WBD2G

DIMENSIONS

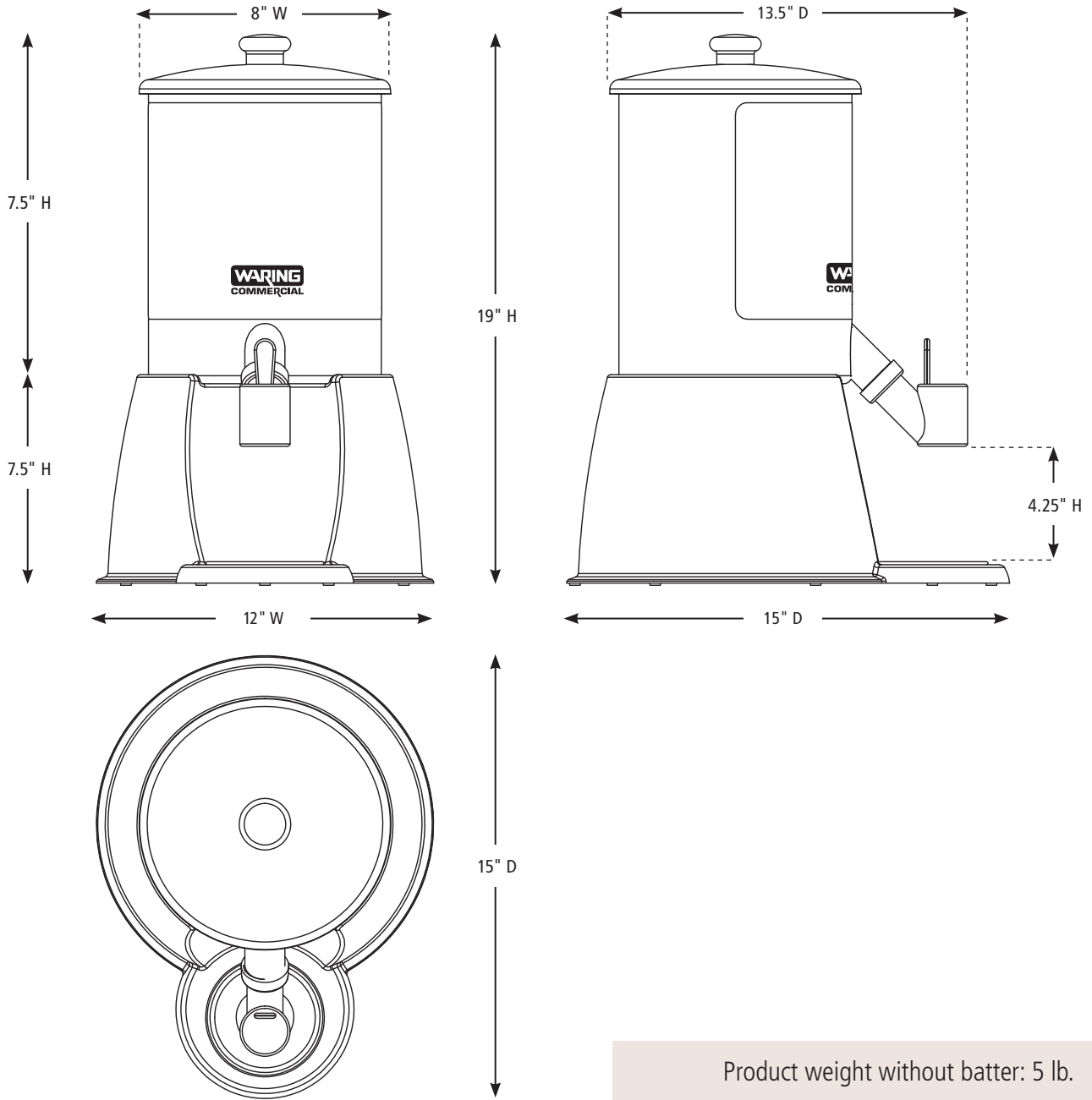

Product weight without batter: 5 lb.

ORDERING INFORMATION	#STD. PKG.	GIFTBOX WEIGHT	CUBIC FEET	BOX DIMENSIONS D X W X H	UPC	CASE PKG.	MC WEIGHT	MC DIMENSIONS D X W X H	MBC
WBD2G – 2-Gallon Batter Dispenser	1	7.03	1.279	16.375" x 12.750" x 17.750"	040072091377	1	7.03	16.375" x 12.750" x 17.750"	10040072091374



@waringcommercial

©2020 Waring Commercial
314 Ella T. Grasso Avenue, Torrington, CT 06790
Tel. 800-492-7464 • Fax 860-496-9008

waringcommercialproducts.com

20WC074577 / REV 10/20