

# INSTALLATION & ASSEMBLY

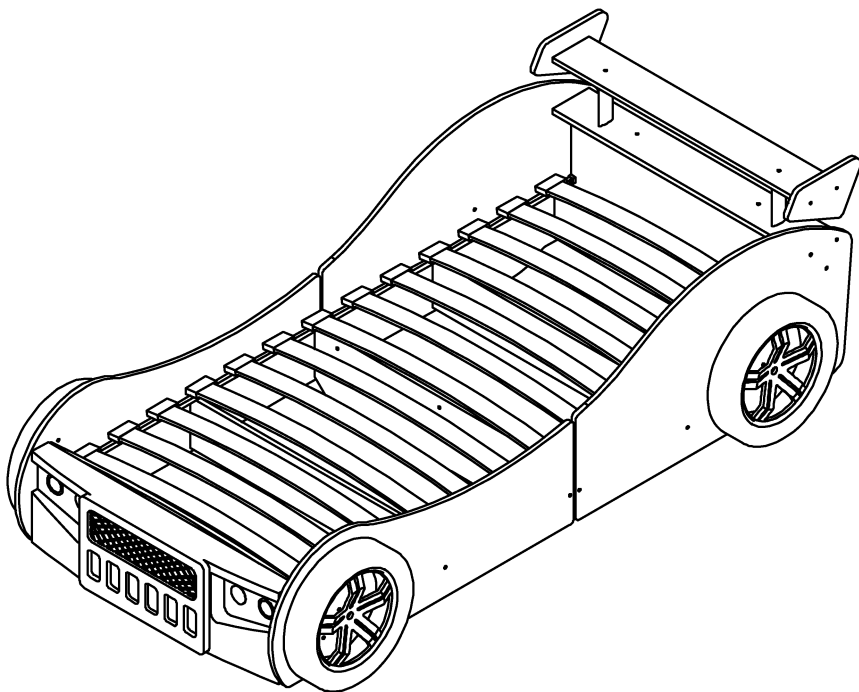

ASSEMBLE DIFFICULTY

1 2 ③ 4 5

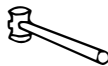









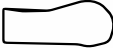







- User Age: 72 Months Or Above.
- Standard Of Paint: EN1725:1998  
EN1022:2005  
EN71-1:2014  
EN71-3:2013+A1:2014

IMPORTANT, RETAIN FOR FUTURE REFERENCE: READ CAREFULLY

- Information regarding maintenance  
Use dry, clean & soft cloth rub on the surface regularly; must not use any wet cloth, hardware or any hard material (such as keys, knife, sand-paper) rub on the surface. Keep away from water and any chemical substances.
- Conditions for use of the product domestic
- Installation only to be carried out by a competent person
- Article consists swallowable small parts, children  $\leq 3$  years should not be without parental guidance (surveillance or monitoring)
- Screw lock must be inserted before joining
- For the safety reason all of the hardware must be screwed tidely.
- This Product must be assembled by adult
- To avoid surface damage, tight all serew must not use over 5Nm power.

## DESCRIPTION OF COMPONENT

ITEM NO	WORK PIECE DESCRIPTION	MEASUREMENT	QTY	COLOUR	SHAPE	PACK IN BOX
(1)	FRONT SIDE BOARD(L)	1066*439*15	1	BLUE		1/2
(2)	FRONT SIDE BOARD(R)	1066*439*15	1	BLUE		1/2
(3)	FRONT SIDE BOARD(L)	1066*593*15	1	BLUE		1/2
(4)	REAR SIDE BOARD(R)	1066*593*15	1	BLUE		1/2
(5)	U SHAPED IRON-1	953*15*15	2	SILVER		1/2
(6)	U SHAPED IRON-2	953*15*15	2	SILVER		1/2
(7)	BACK PANEL	1000*354*15	1	BLUE		1/2
(8)	REAR UPPER MIDDLE FILTER	1000*135*15	1	BLUE		1/2
(9)	REAR LOWER MIDDLE FILTER	1000*135*15	1	BLUE		1/2
(10)	BEAM	1000*100*15	4	WHITE		1/2
(11)	MIDDLE HORIZONTAL PLATE	1000*100*15	2	WHITE		1/2
(12)	ARTICLE RIBS	140*25*20	2	WHITE		2/2
(13)	REAR UPPER SIDE BOARD(L)	272*162*15	1	BLUE		2/2
(14)	REAR UPPER SIDE BOARD(R)	272*162*15	1	BLUE		2/2
(15)	CONNECTED IRON	150*50*20	2	BLACK		2/2
(16)	FRONT PANEL (ITEM 12-14 INCLUDED IN THIS PART)	1000*300*15	1	BLUE		2/2
(17)	TYRE (ITEM 16-17 INCLUDED IN THIS PART)	380*380*62	4	BLACK		2/2
(18)	HARDWARE	216*114*57	1	BROWN		2/2
(19)	PLYWOOD SLAT	995*62*12	13	WHITE		2/2





1

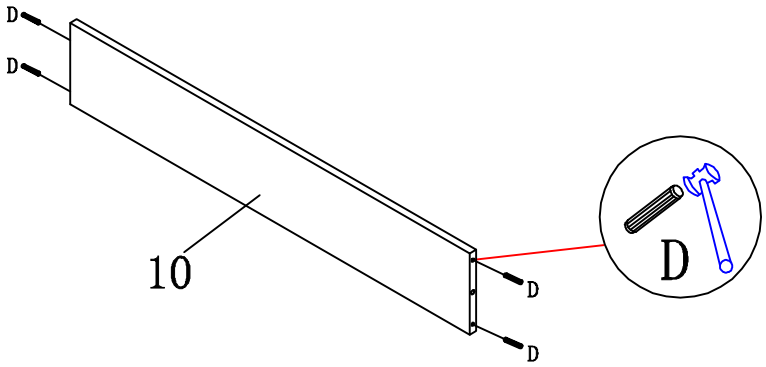

4X

D



d6\*30  
QTY: 16

2

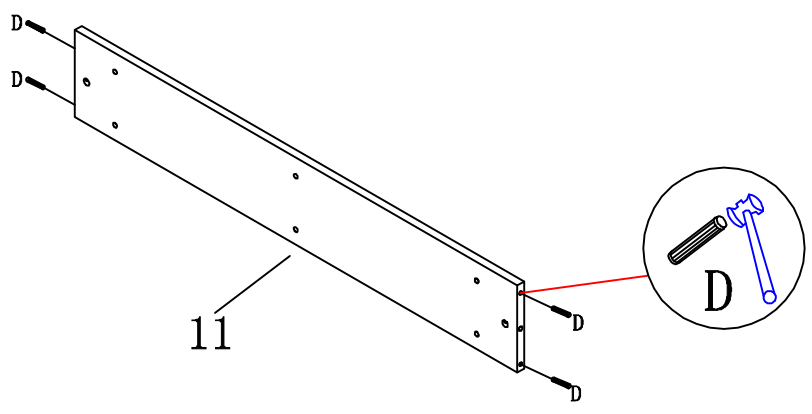

2X

D



d6\*30  
QTY: 8

3

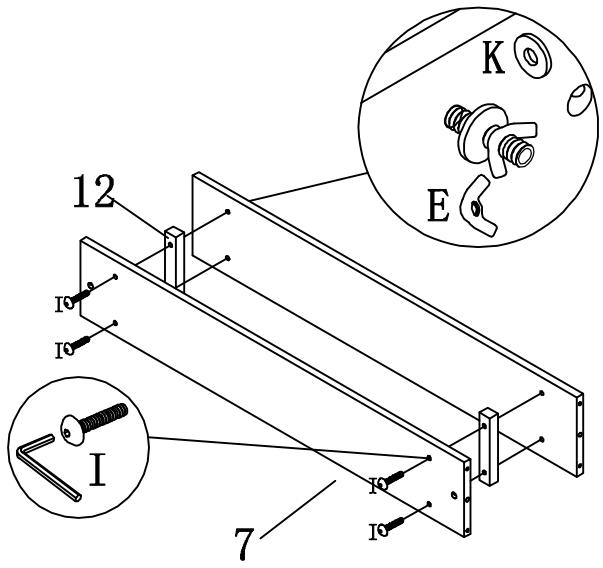

I	 M6*70 QTY:4	E	 QTY:4	K	 QTY:4
---	--	---	---	---	---

4

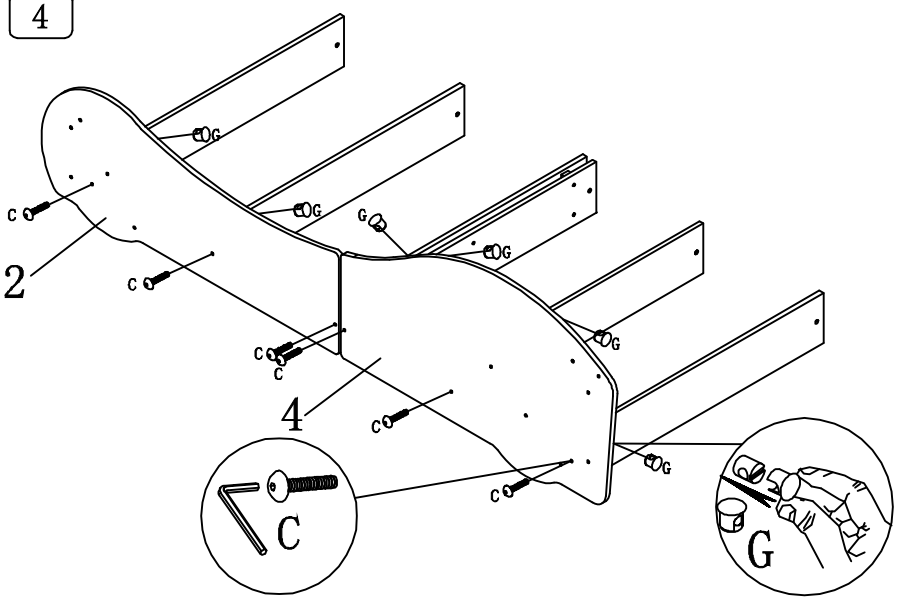

C	 M6*50 QTY:6	G	 QTY:6
---	--	---	---

5

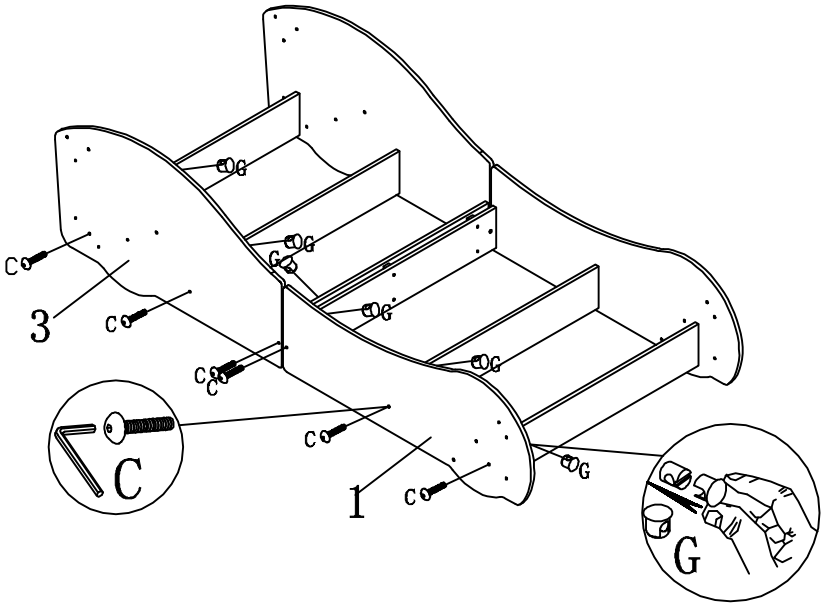

C



M6\*50  
QTY:6

G



QTY:6

6

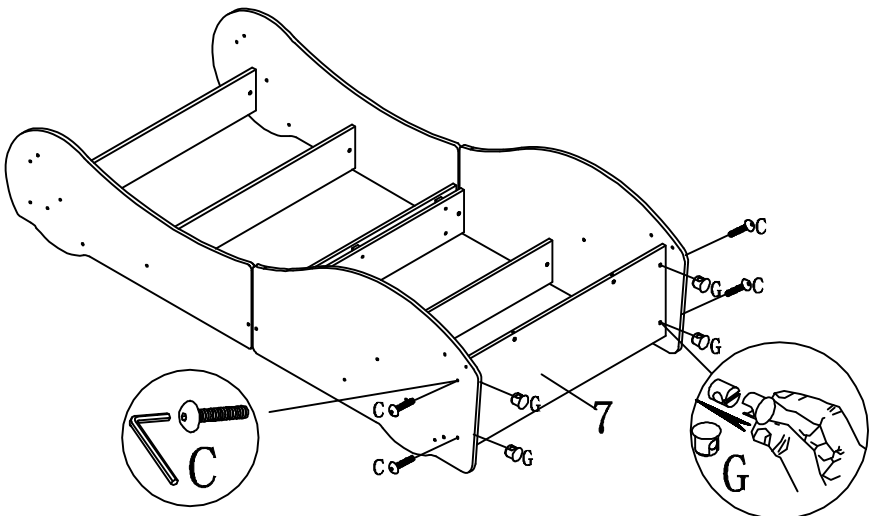

C



M6\*50  
QTY:4

G



QTY:4

7

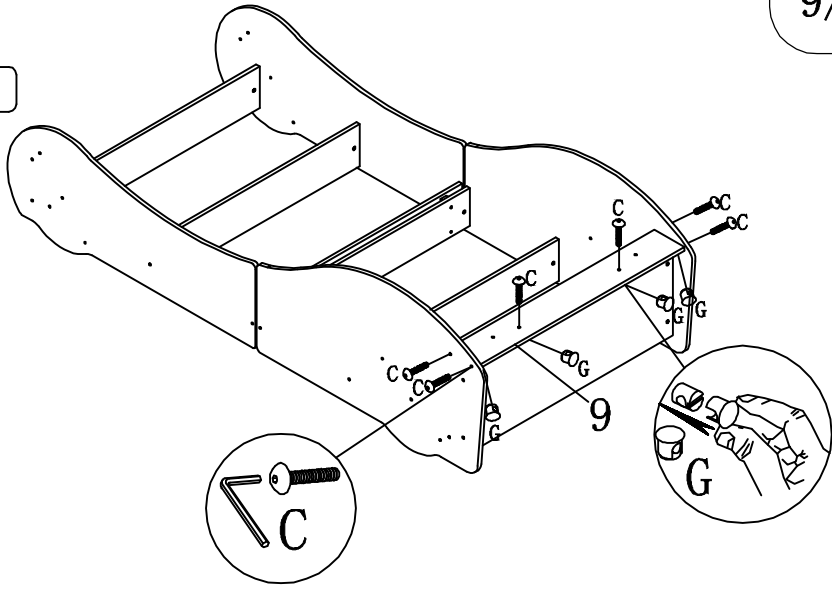

C  M6\*50  
QTY:6

G   QTY:6

8

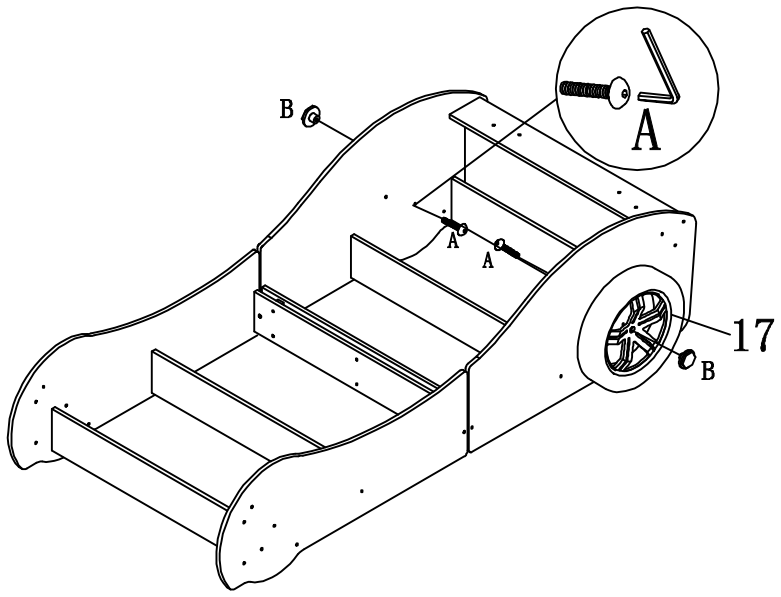

A  M6\*55  
QTY:2

B  QTY:2

10/14

9

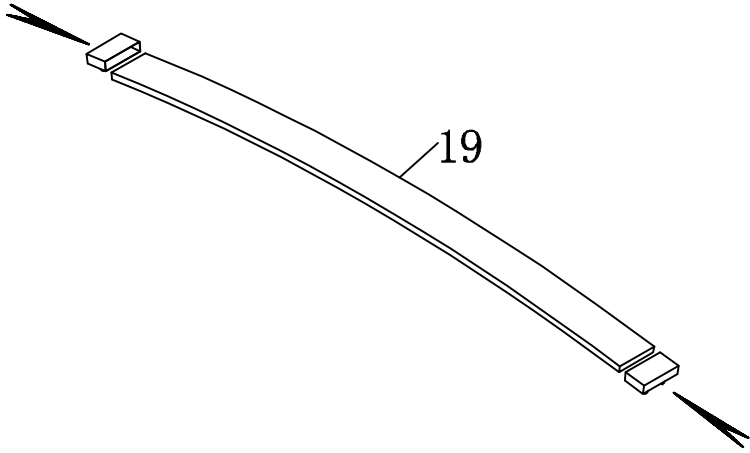

19

13X

F



QTY:26

10

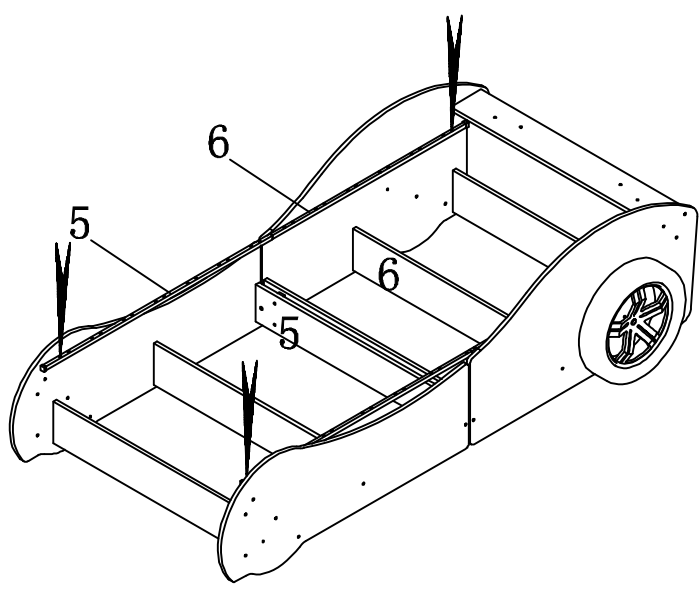

5

6

6

5

11

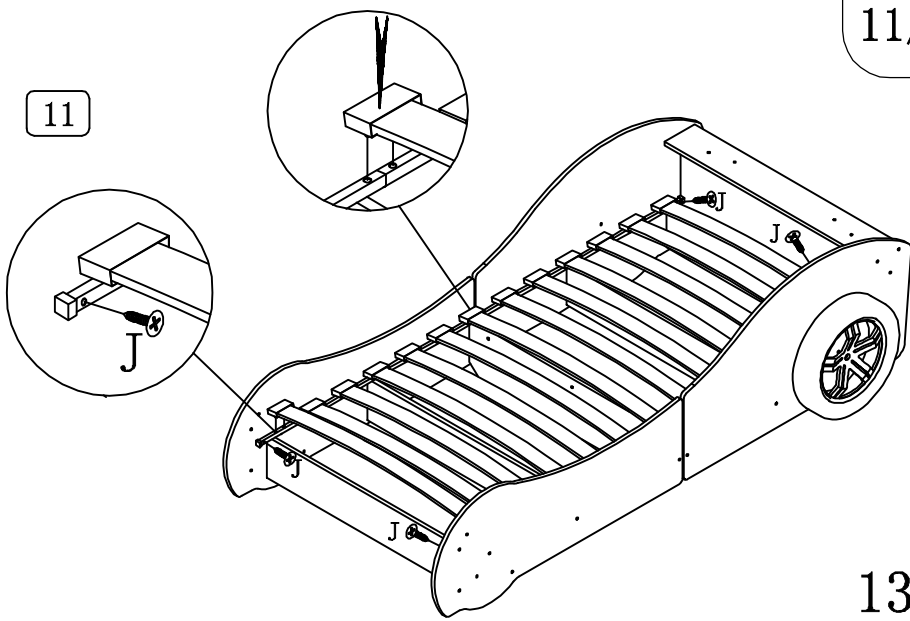

13X

J  4#\*30  
QTY:4

12

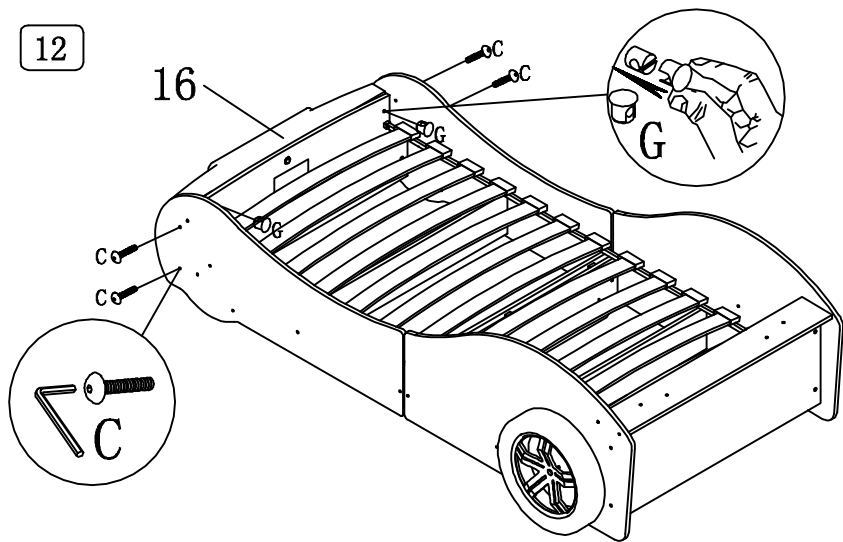

C  M6\*50  
QTY:4

G  QTY:4

13

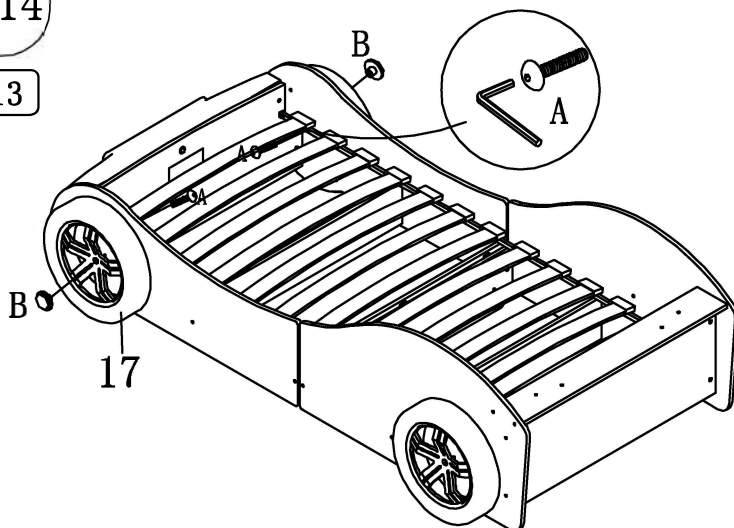

A

M6\*55  
QTY:2

B



QTY:2

14

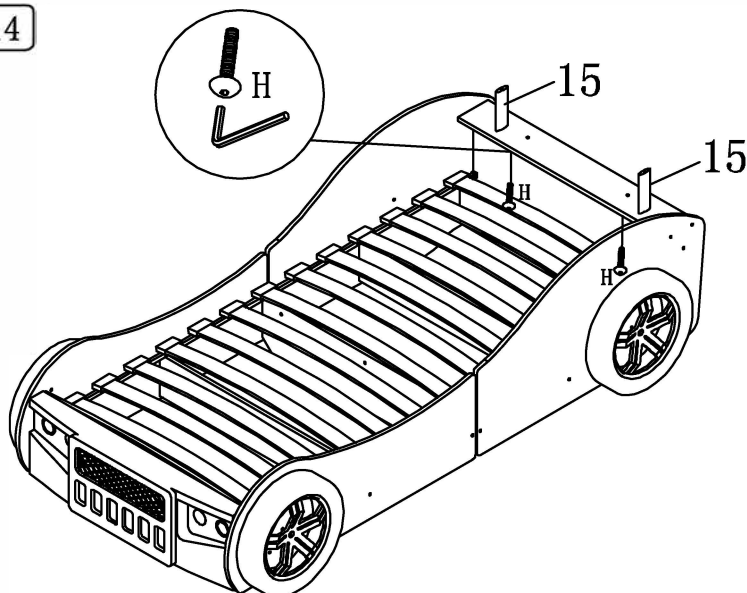

H

M6\*40  
QTY:2

15

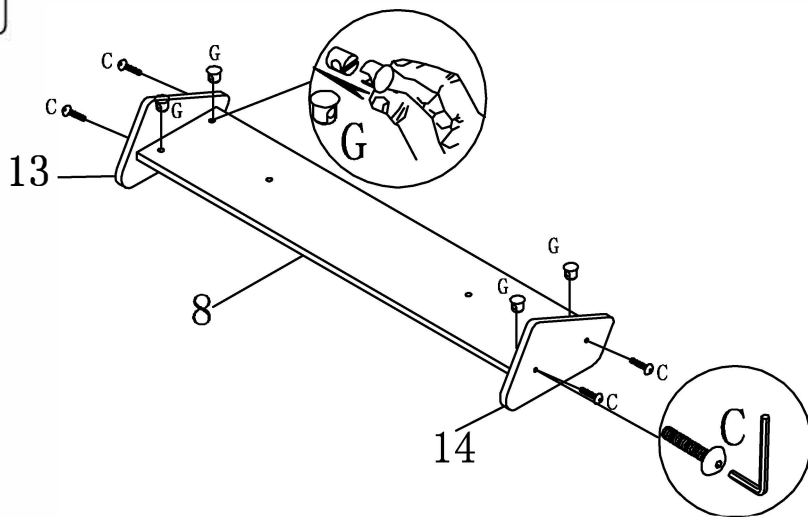

C

M6\*50  
QTY:4

G



QTY:4

16

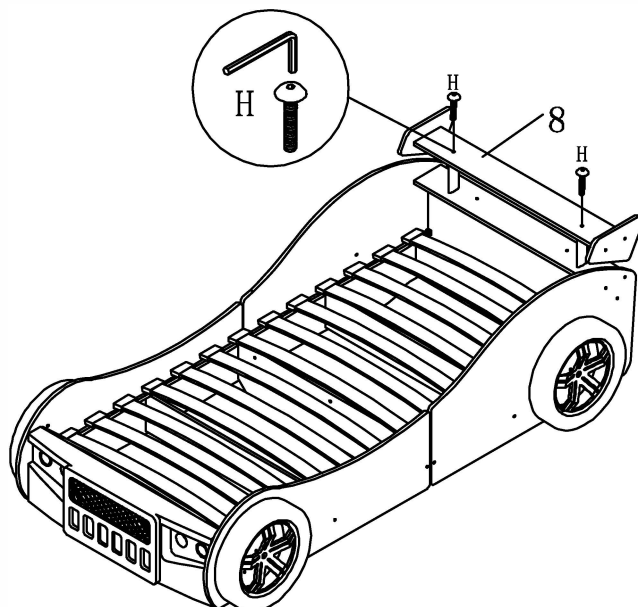

H

M6\*40  
QTY:2

