

ASSEMBLY INSTRUCTION

DOG CAGE

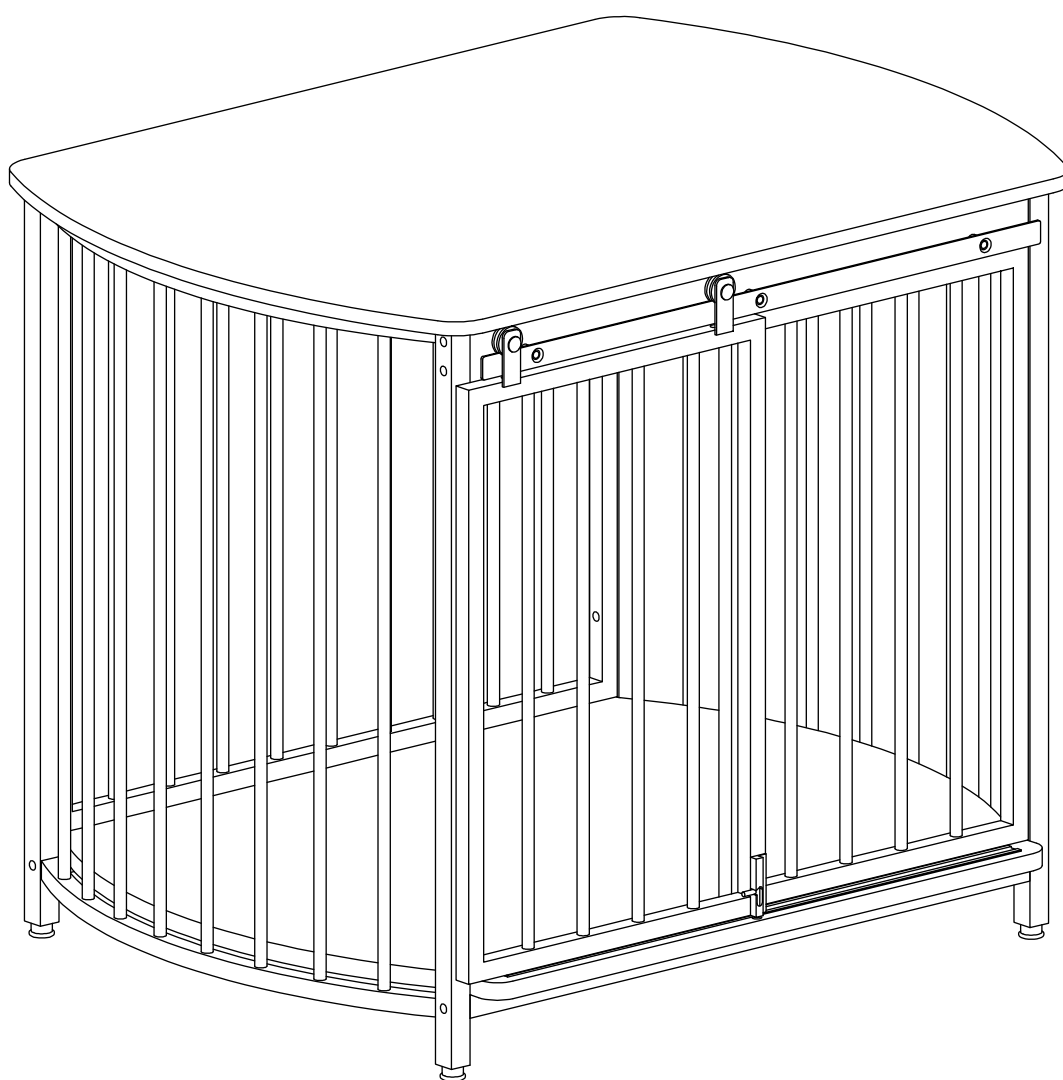

ASSEMBLY INSTRUCTION

Important- Please read these instructions fully before starting assembly

Tools required: Phillips screwdriver (medium & large)

1. Check you have all the components and tools listed on the following pages.
2. Remove all fittings from the plastic bags and separate them into their groups.
3. Keep children and animals away from the work area, small parts could choke if swallowed.
4. Make sure you have enough space to layout the parts before starting.
5. During assembly do not stand or put weight on the product, this could cause damage.
6. Assemble the item as close to its final position (in the same room) as possible.
7. Assemble on a soft level surface to avoid damaging the unit or your floor.
8. Parts of the assembly will be easier with 2 people.
9. To reduce the likelihood of damaging your product please ensure that your power drill is set on a low torque setting.
10. Assemble all parts and bolts loosely during assembly, only once the product is complete should you fully tighten the bolts
11. Regularly check and ensure That all bolts and fittings are tightend properly.
12. Please do not place items that exceed the load capacity.

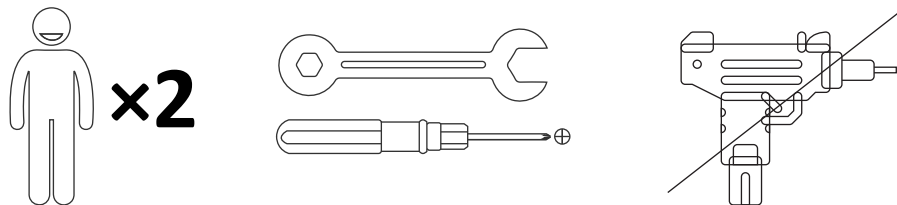

We recommend using hand tools for assembly.

If an electric screwdriver is used, reduce power and torque to avoid damage to the product.

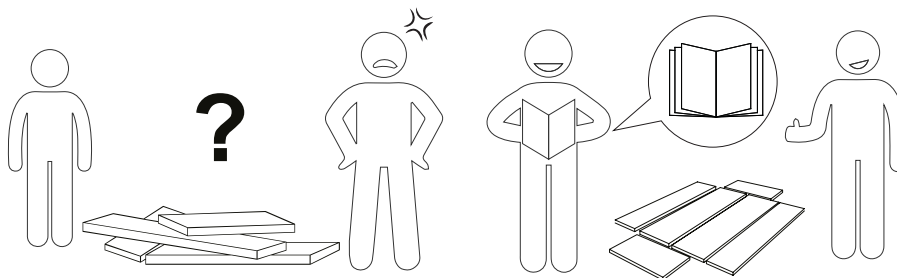

Care and maintenance:





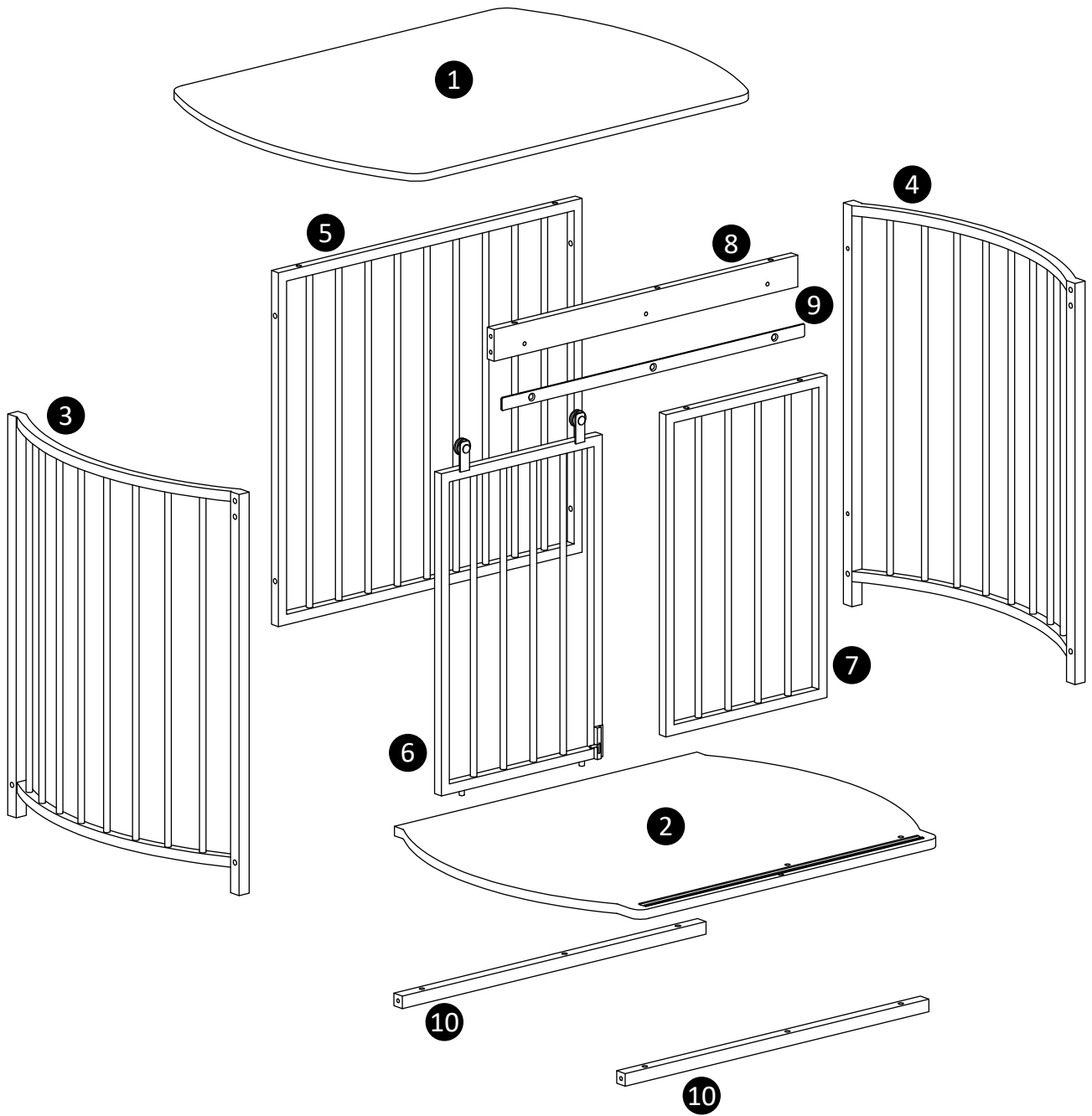

Only clean using a damp cloth and mild detergent, do not use bleach or abrasive cleaners.

ASSEMBLY INSTRUCTION



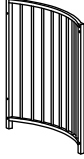

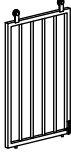
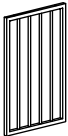
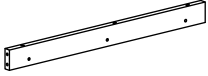
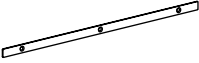

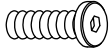

ASSEMBLY INSTRUCTION

Part List

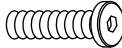
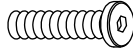
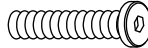
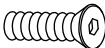
<p>① ×1</p>  <p>Top</p>	<p>② ×1</p>  <p>Bottom</p>	<p>③ ×1</p>  <p>Left frame</p>	<p>④ ×1</p>  <p>Right frame</p>	<p>⑤ ×1</p>  <p>Back frame</p>
<p>⑥ ×1</p>  <p>Sliding door</p>	<p>⑦ ×1</p>  <p>Front frame</p>	<p>⑧ ×1</p>  <p>Brace</p>	<p>⑨ ×1</p>  <p>Track</p>	<p>⑩ ×2</p>  <p>Bottom brace</p>

Hardware List

<p>A × 6</p>  <p>M6×25mm Bolt</p>	<p>B × 4</p>  <p>M6×30mm Bolt</p>	<p>C × 8</p>  <p>M6×40mm Bolt</p>	<p>D × 2</p>  <p>M6×45mm Bolt</p>	<p>E × 1</p>  <p>M6×58mm Bolt</p>	<p>F × 2</p>  <p>M6×75mm Bolt</p>
<p>G × 3</p>  <p>M6×25mm Bolt</p>	<p>H × 1</p>  <p>M4×55mm Allen key</p>	<p>I × 3</p>  <p>∅11×15mm Plastic connection hoop</p>	<p>J × 4</p>  <p>M6×∅20mm Adjustable feet</p>		

ASSEMBLY INSTRUCTION

Step 01

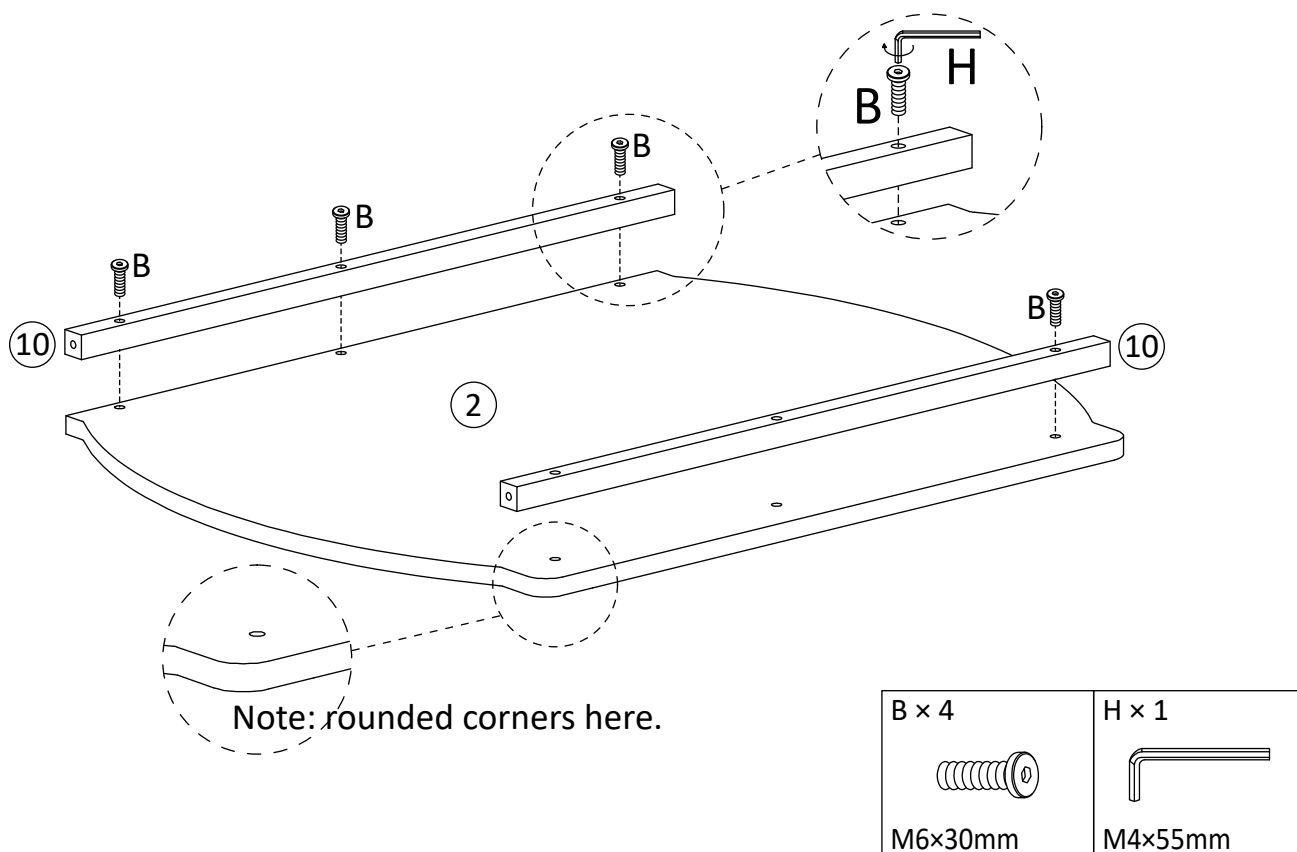

Step 02

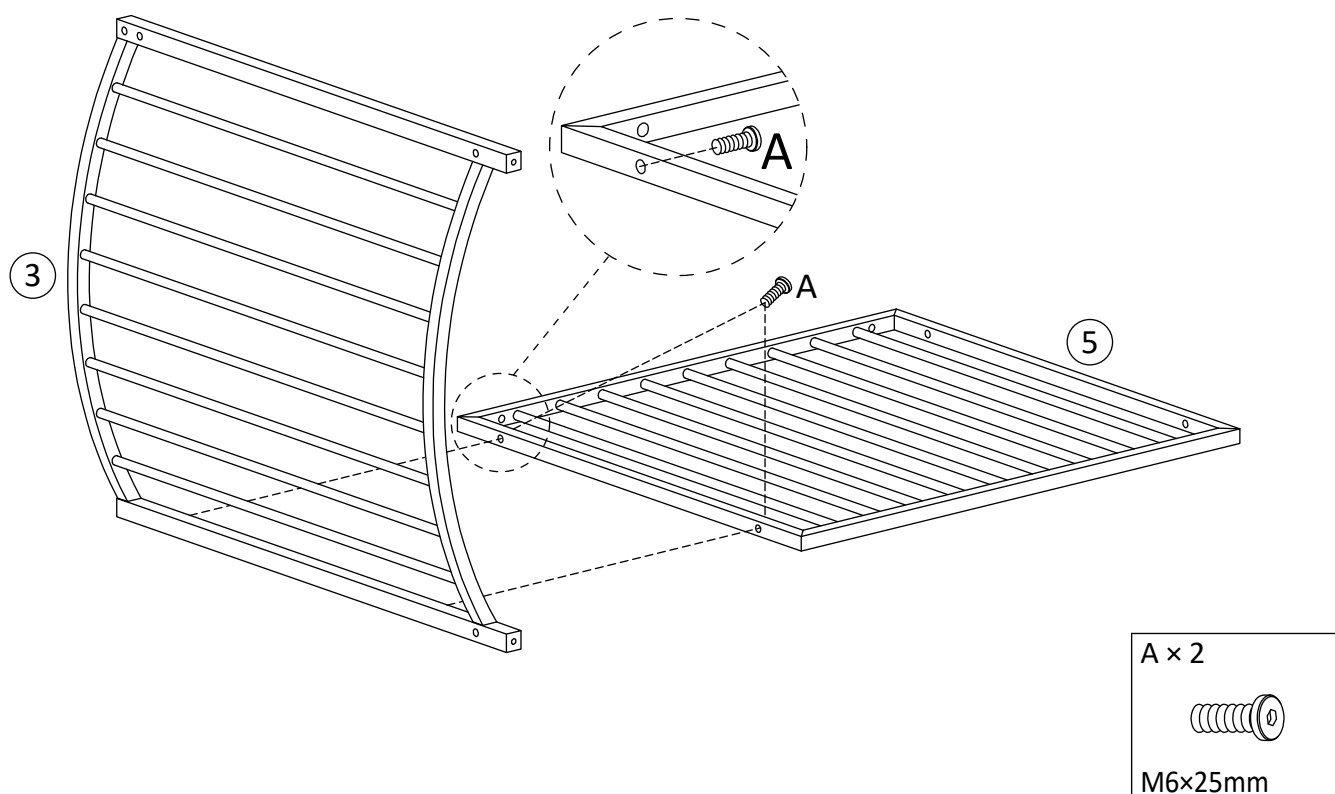

ASSEMBLY INSTRUCTION

Step 03

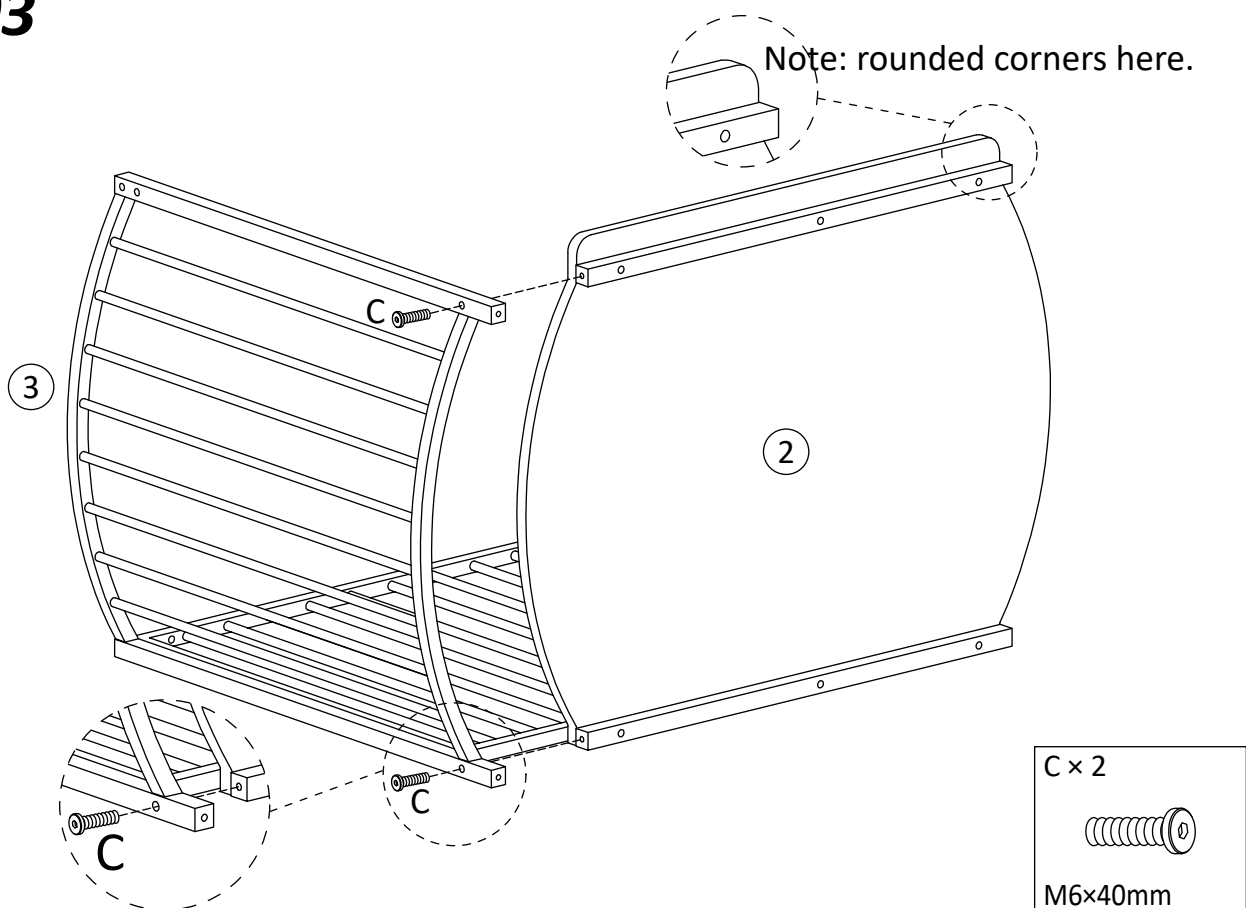

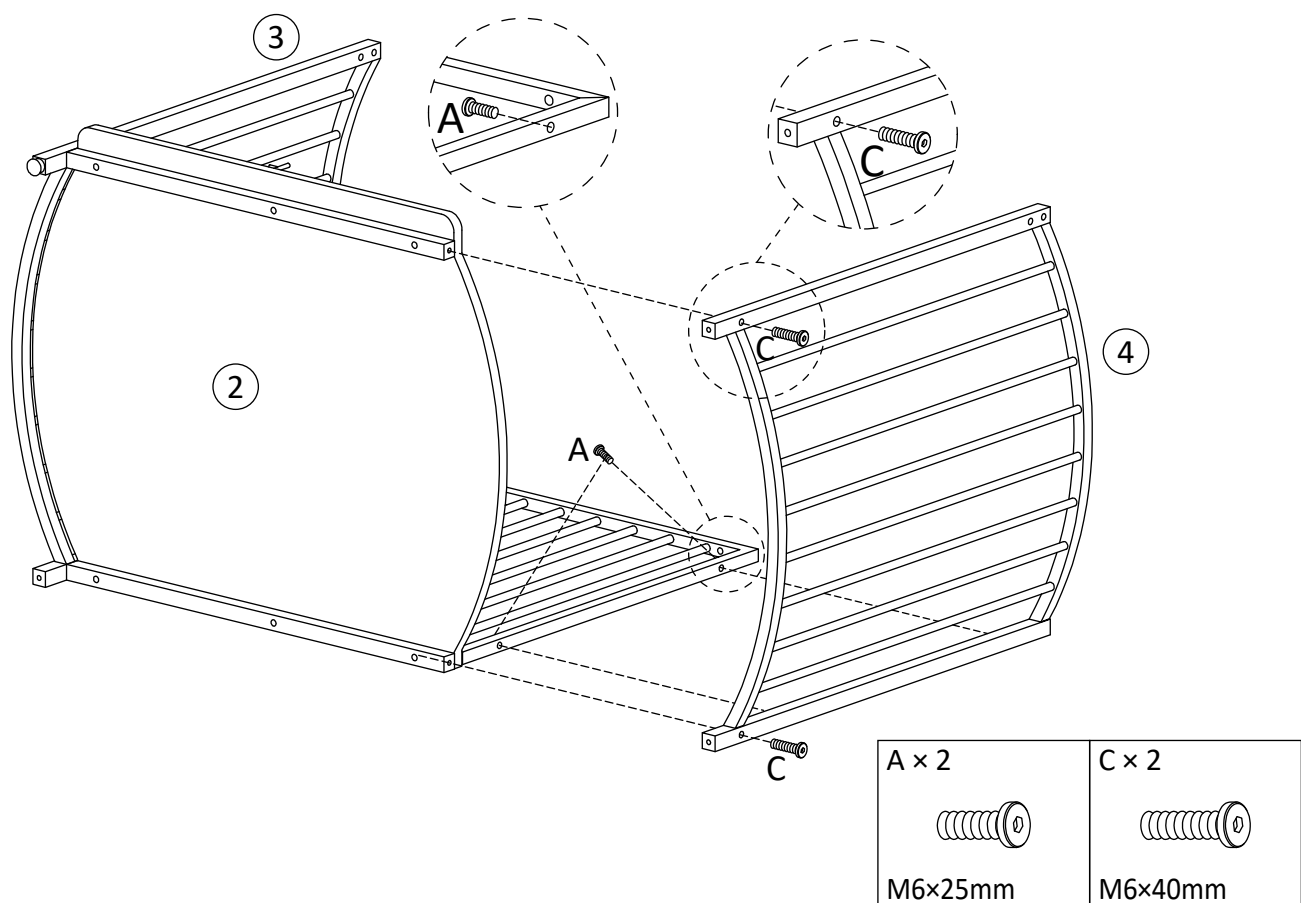

Step 04

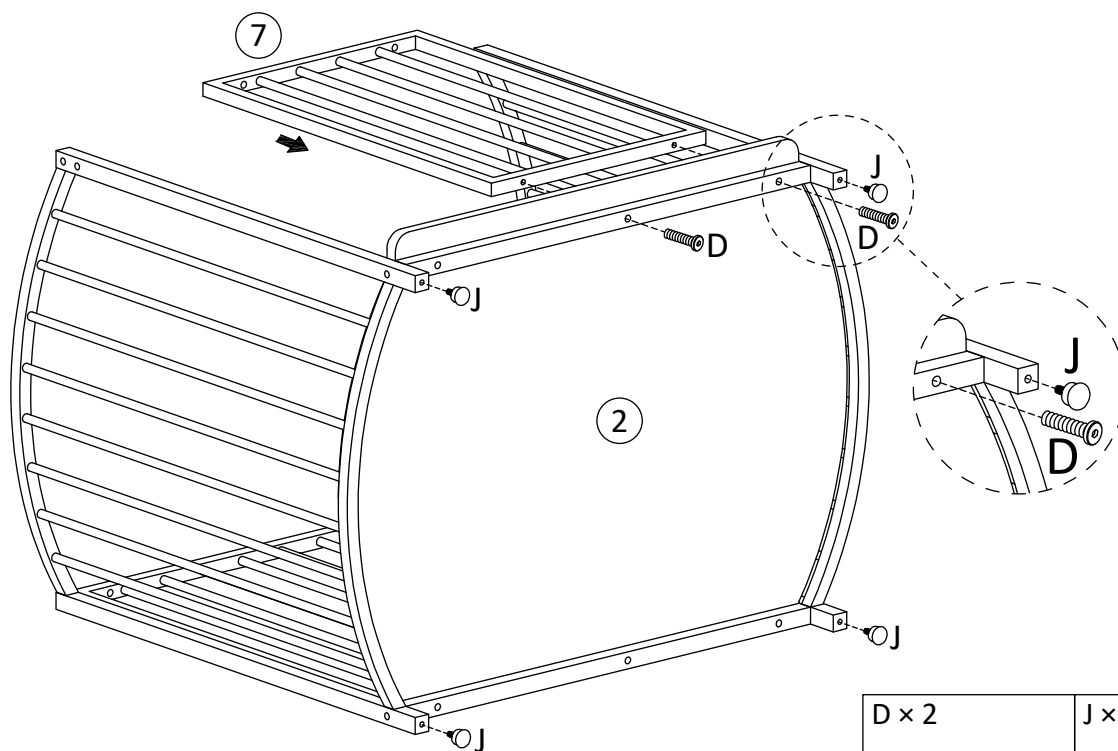

ASSEMBLY INSTRUCTION

Step 05



D × 2	J × 4
	
M6×45mm	M6×Ø20mm

Step 06

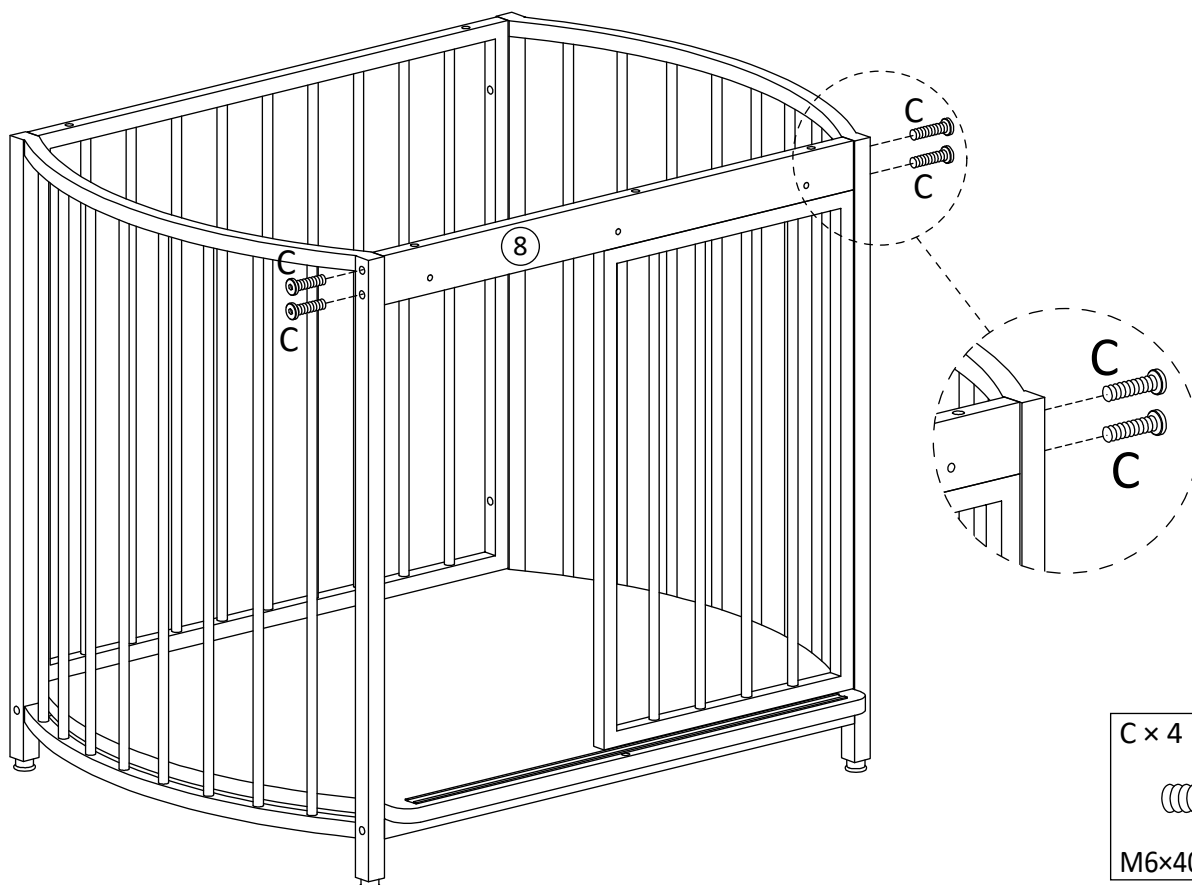

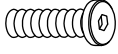
C × 4

M6×40mm

ASSEMBLY INSTRUCTION

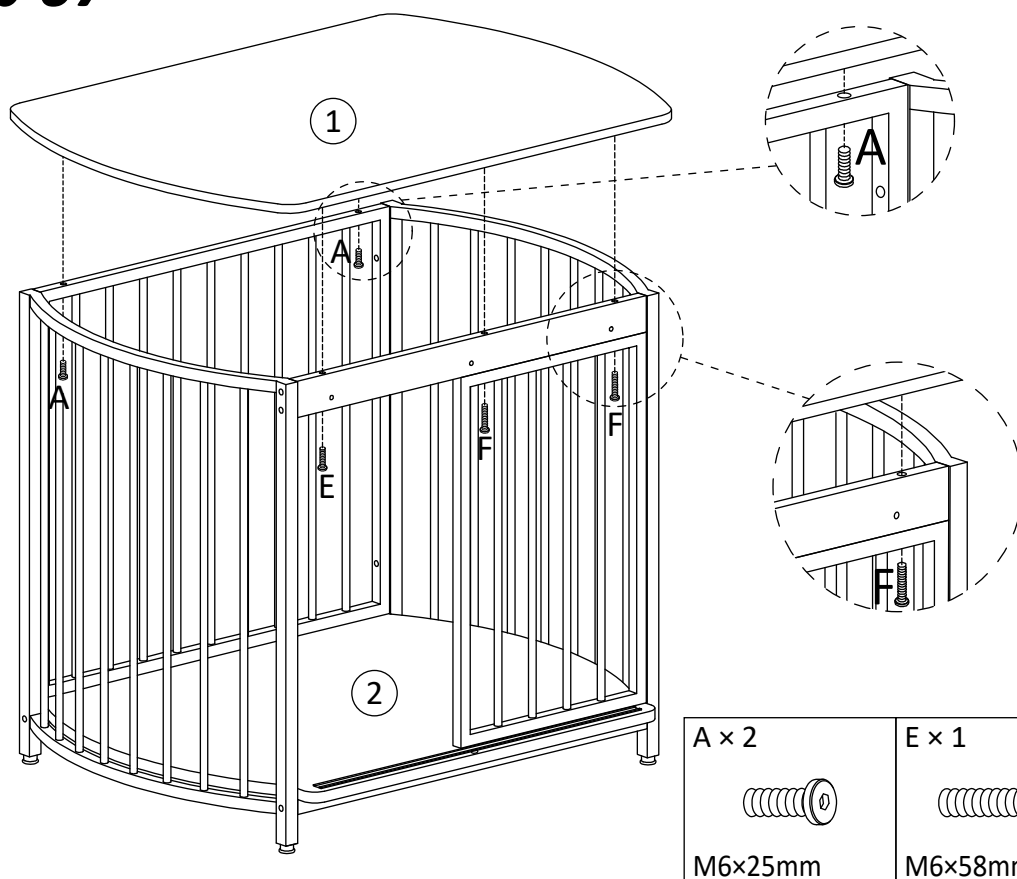
Step 07

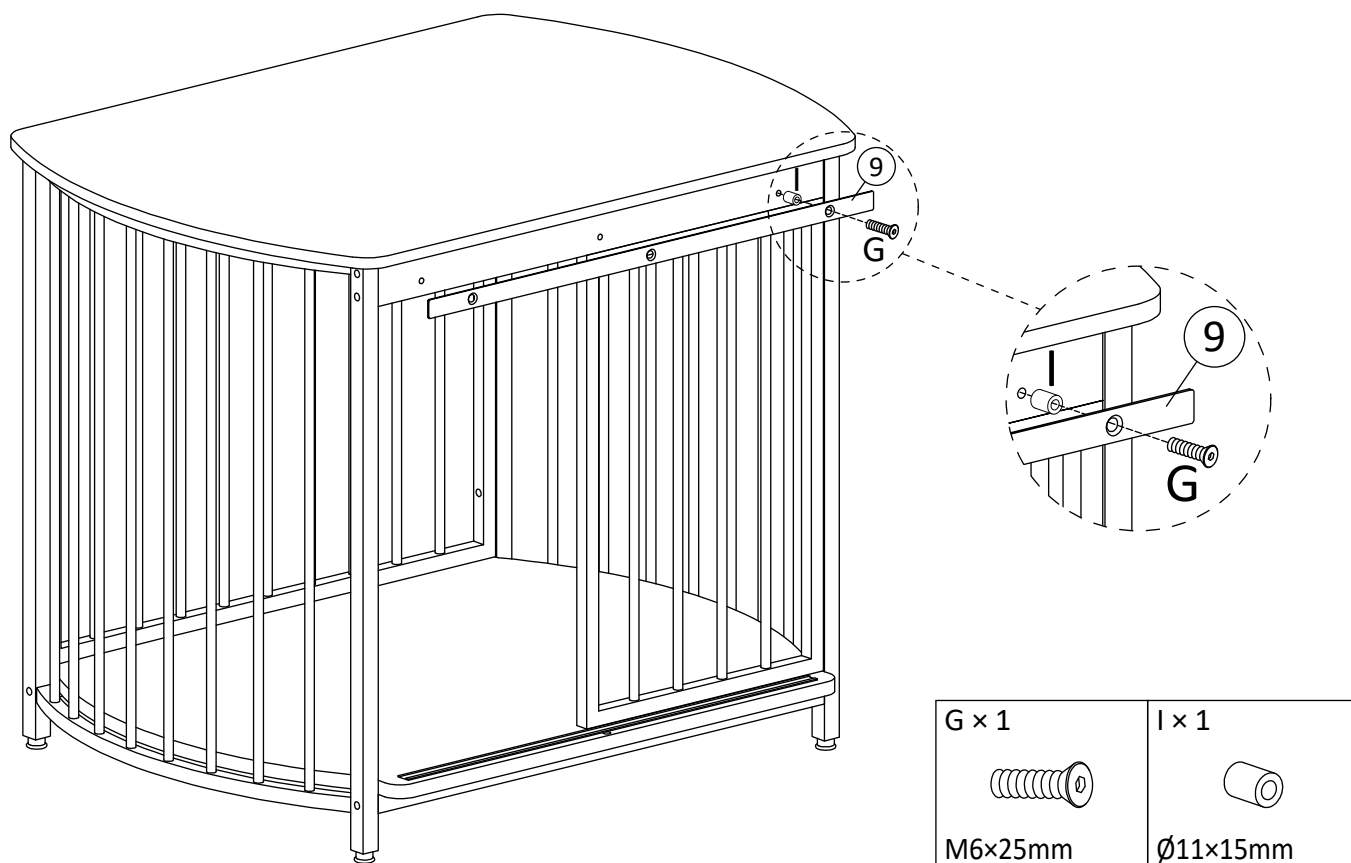

Step 08



ASSEMBLY INSTRUCTION

Step 09

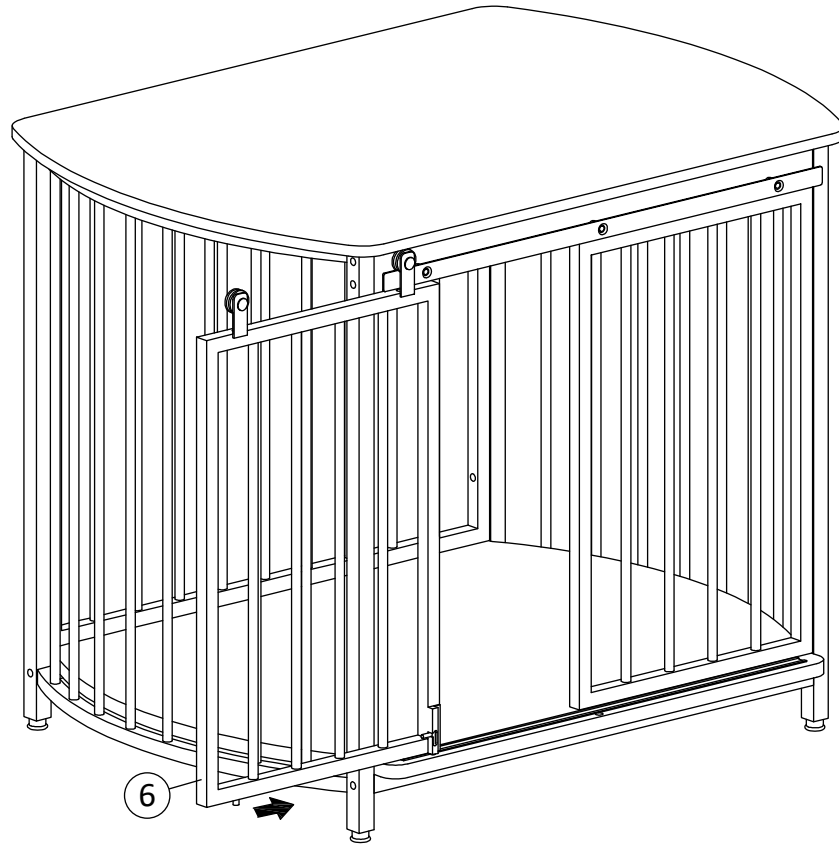

Step 10

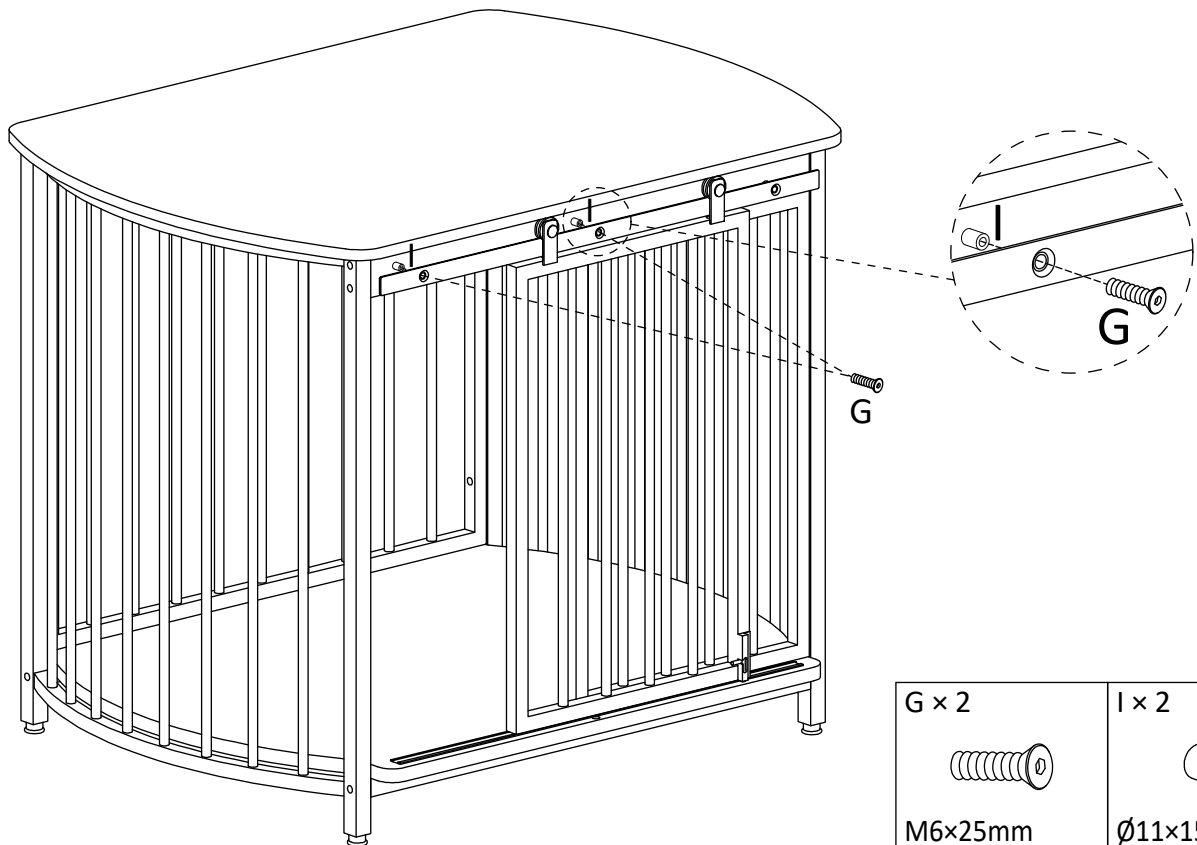

ASSEMBLY INSTRUCTION

Step 11

