

ASSEMBLY INSTRUCTIONS

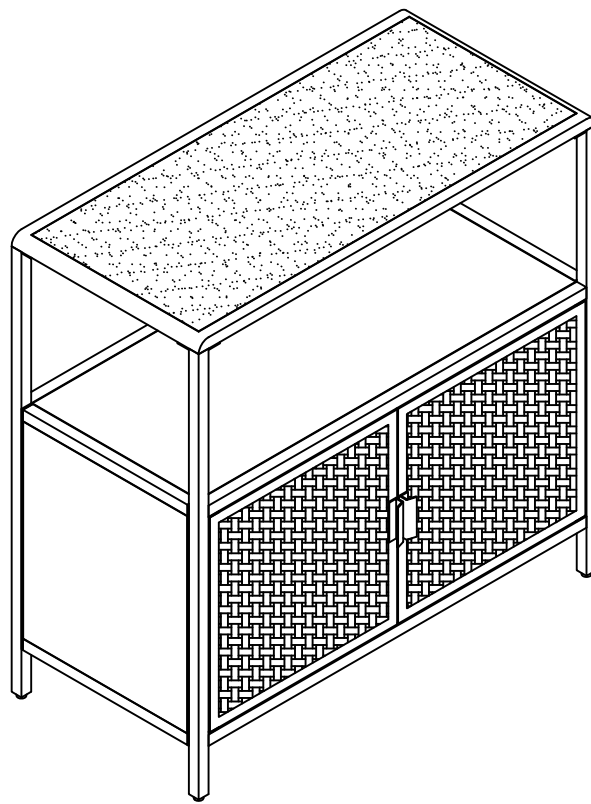

ACCENT CABINET

ASSEMBLY INSTRUCTIONS

ASSEMBLY TIPS:

1. Remove hardware from box and sort by size.
2. Please check to see that all hardware and parts are present prior to start of assembly.
3. Please follow attached instructions in the same sequence as numbered to assure fast & easy assembly.



WARNING !

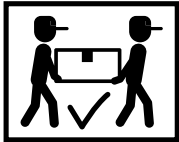

1. Don't attempt to repair or modify parts that are broken or defective. Please contact the store immediately.
2. This product is for home use only and not intended for commercial establishment.





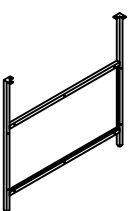
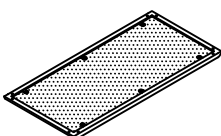
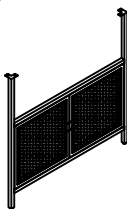
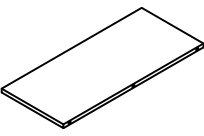
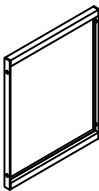

ASSEMBLY TIME

20 MINUTE

PARTS IDENTIFICATION

A	BACK FRAME		1PC	D	TOP		1PC
B	FRONT FRAME		1PC	E	CABINET PANEL		2PCS
C	SIDE FRAME		2PCS	F	HANDLE		2PCS

HARDWARE IDENTIFICATION

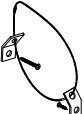
1	BOLT (1/4"x1/2")		16PCS	4	WASHER (φ16mm)		16PCS
2	BOLT (3/16"x1/2")		16PCS	5	ALLEN KEY (4x22x60mm)		1PC
3	WASHER (φ12mm)		16PCS	6	ANTI - TIP KIT		1PC

NOTE:



Phillips head screw driver is required in the assembly process; however, manufacturer does not provide this item.

ASSEMBLY INSTRUCTIONS

STEP 1:



ASSEMBLY

Do not fully tighten all bolts until assembly is complete.
This will help all parts to assemble properly.

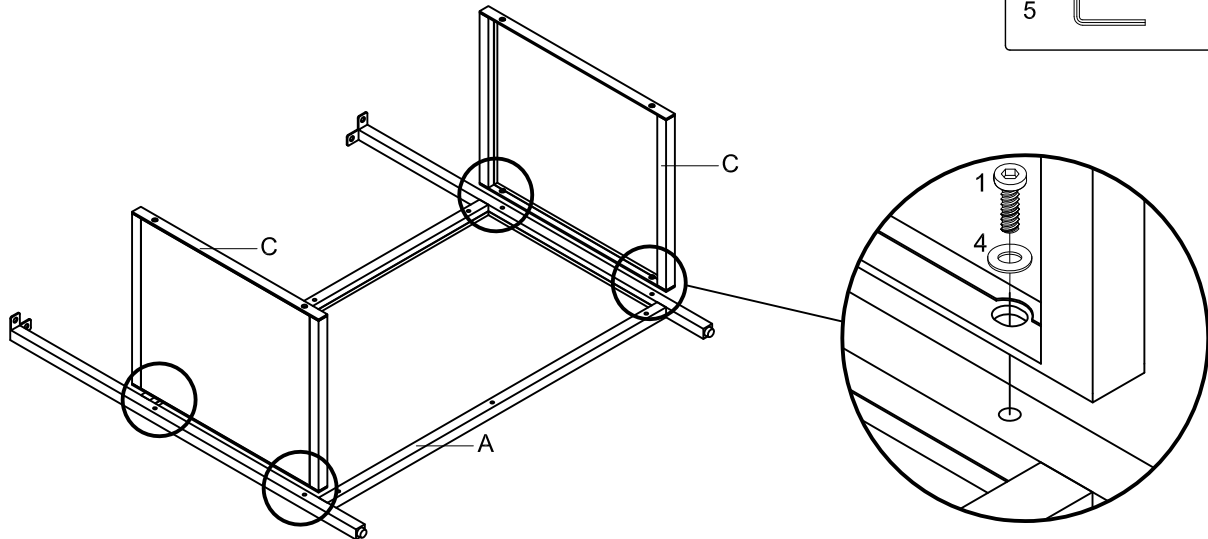
1		4PCS
4		4PCS
5		



STEP 2:

1		4PCS
4		4PCS
5		

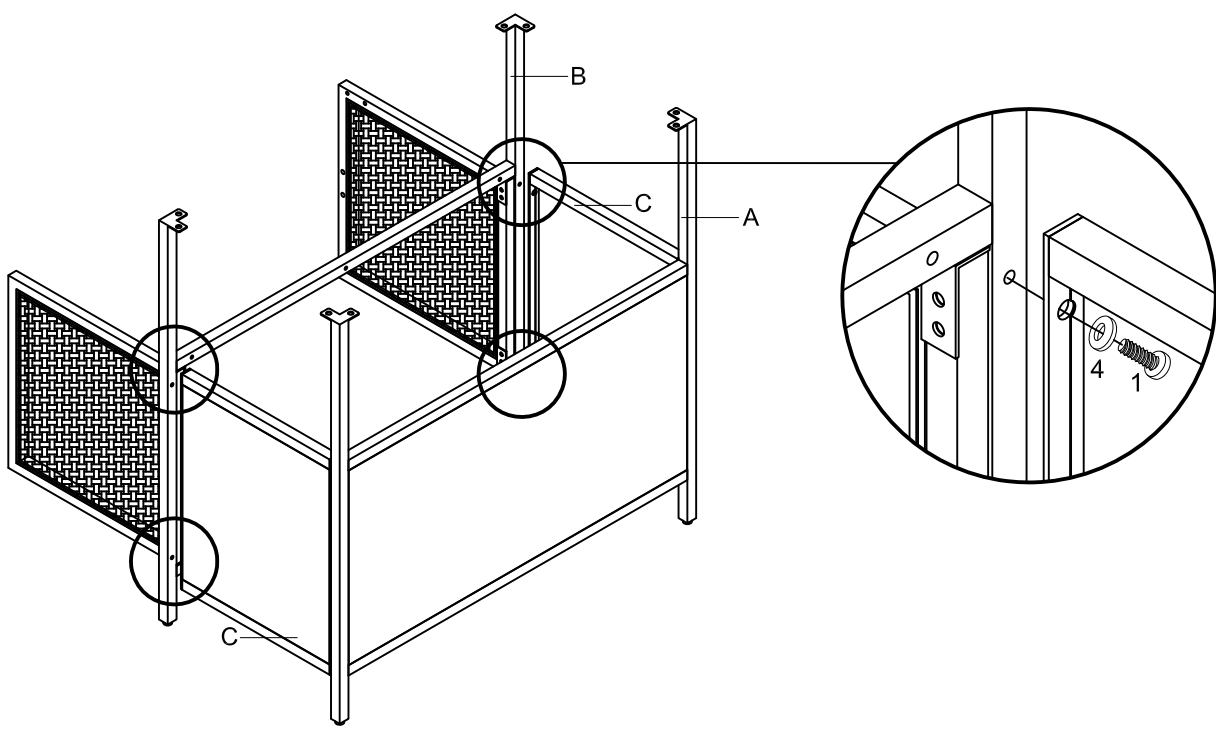

ASSEMBLY INSTRUCTIONS

STEP 3:

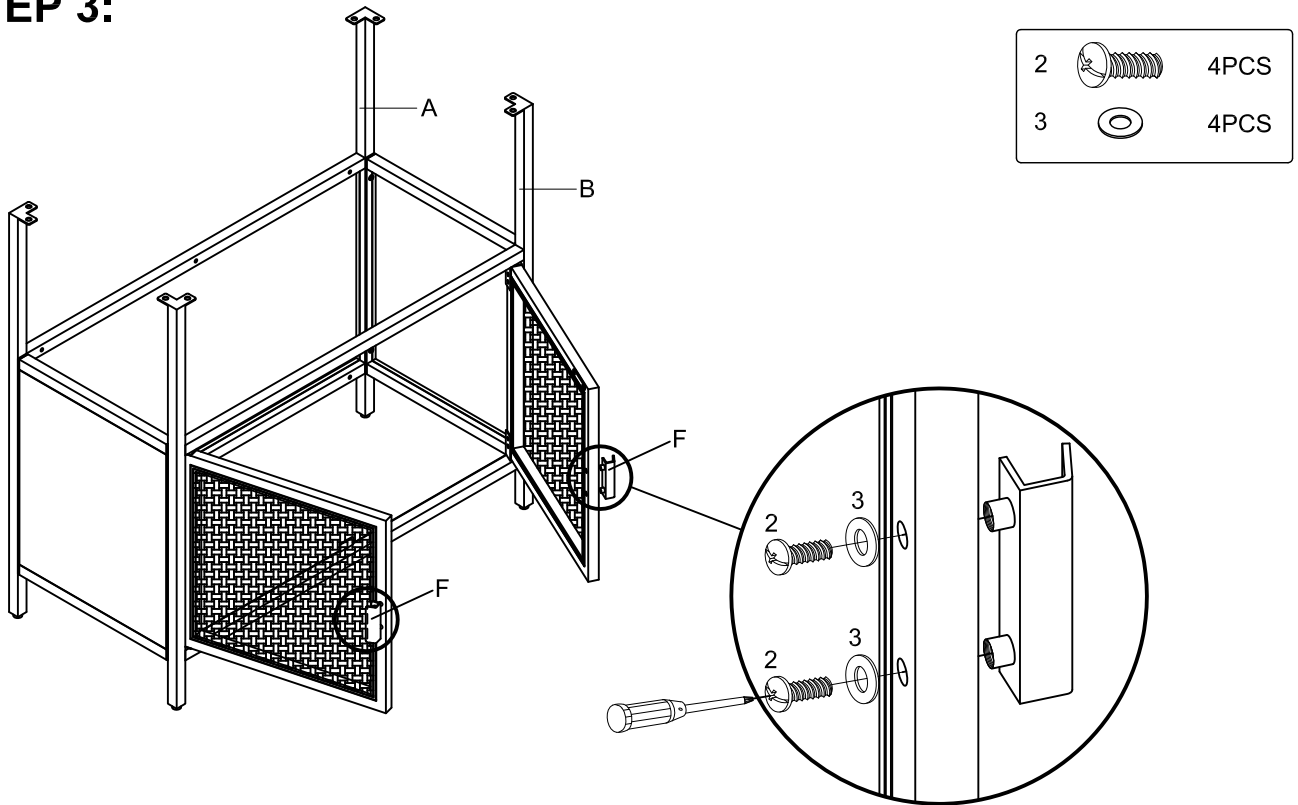

STEP 4:

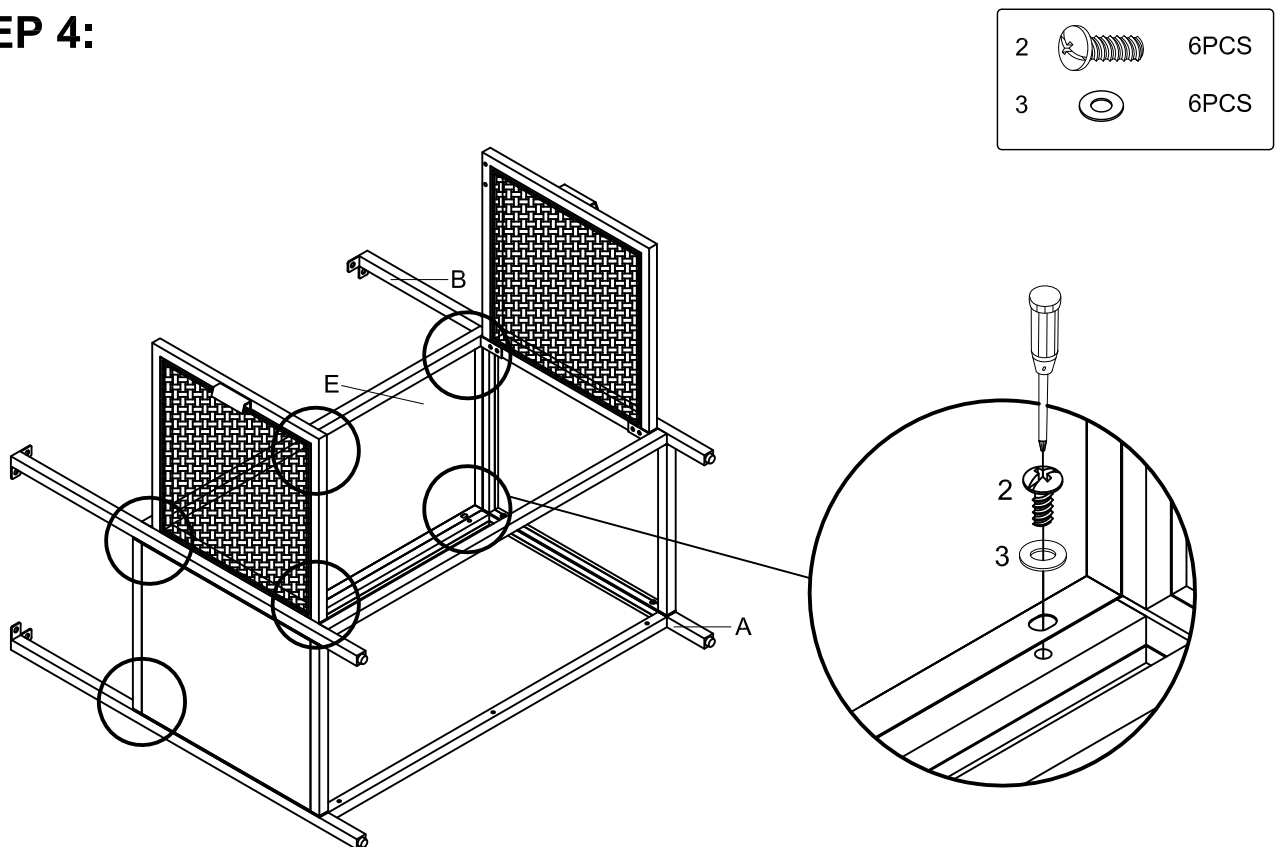

ASSEMBLY INSTRUCTIONS

STEP 5:

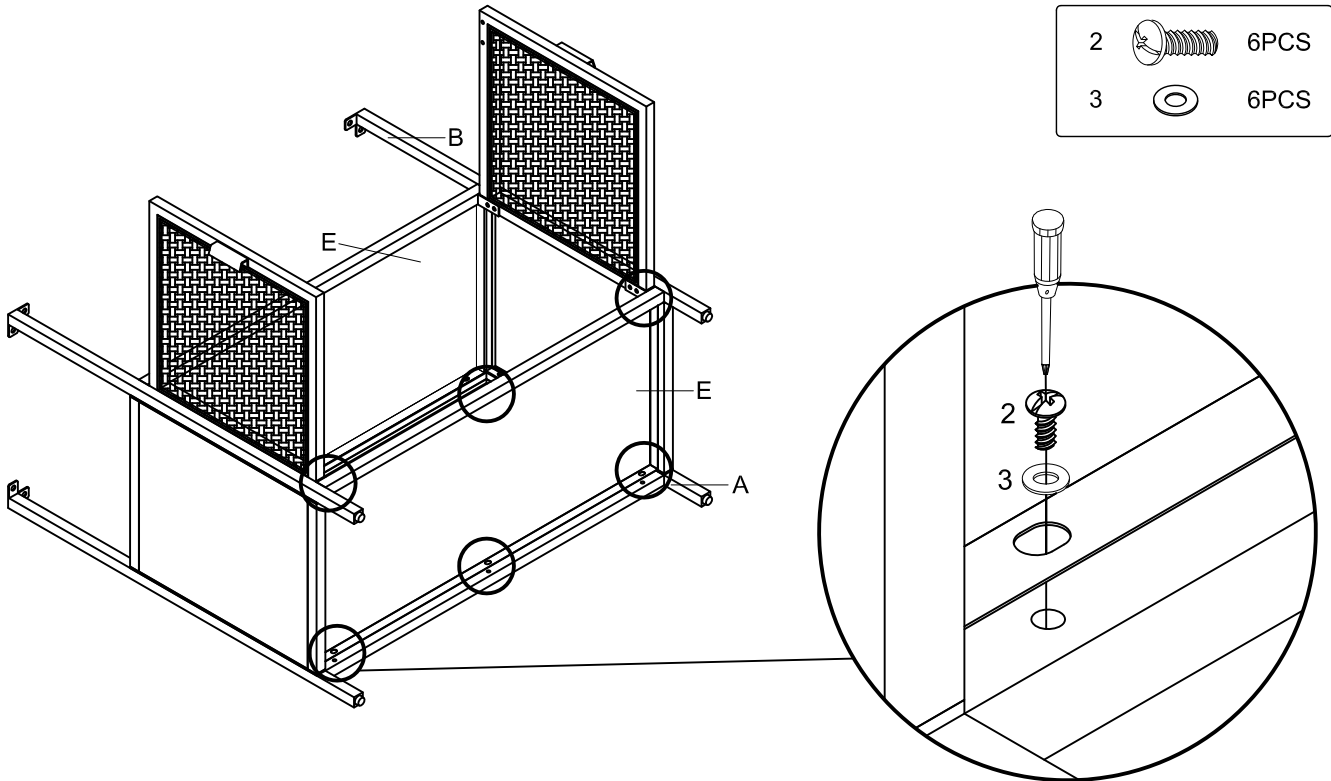

STEP 6:

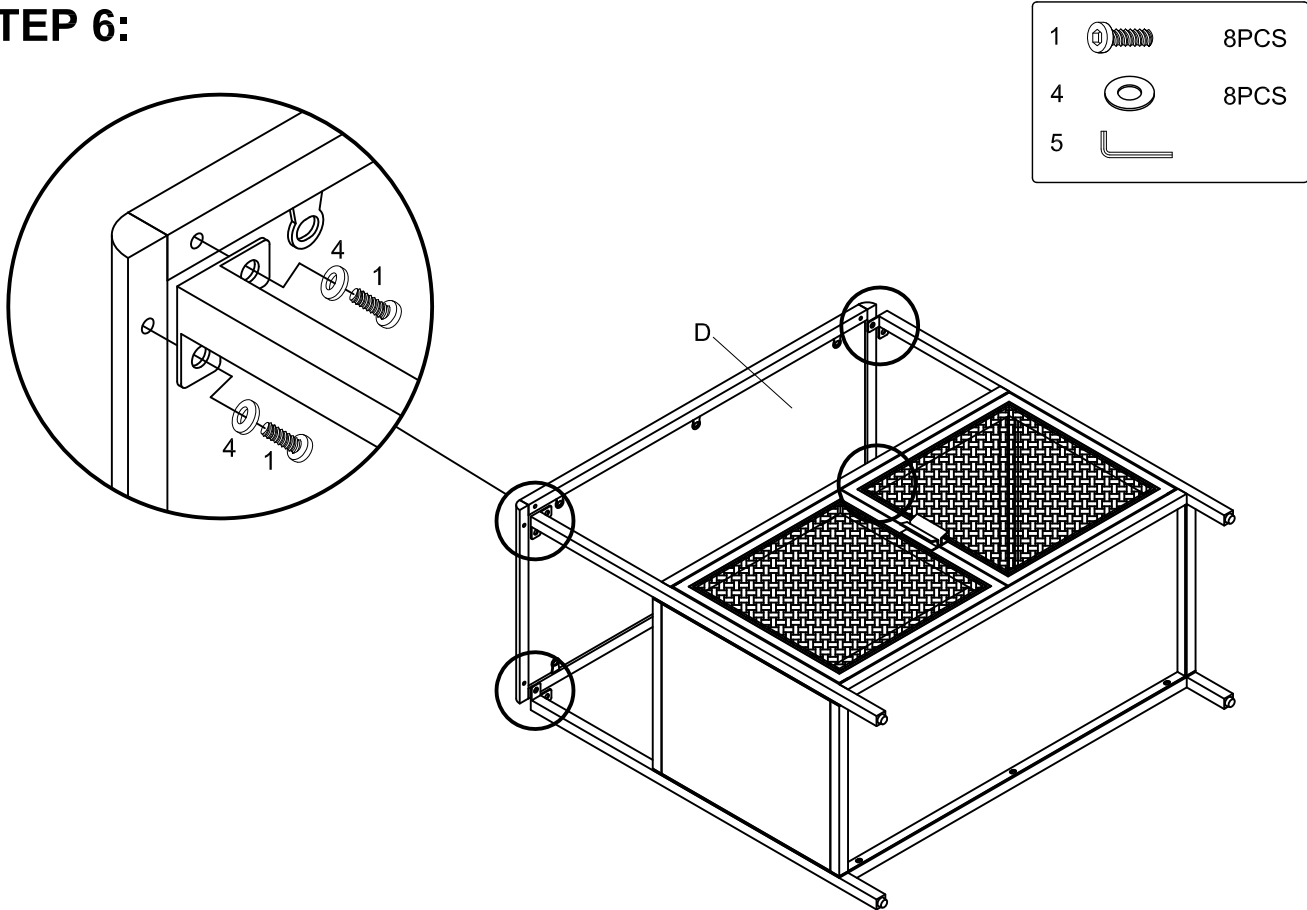

ASSEMBLY INSTRUCTIONS

STEP 7:

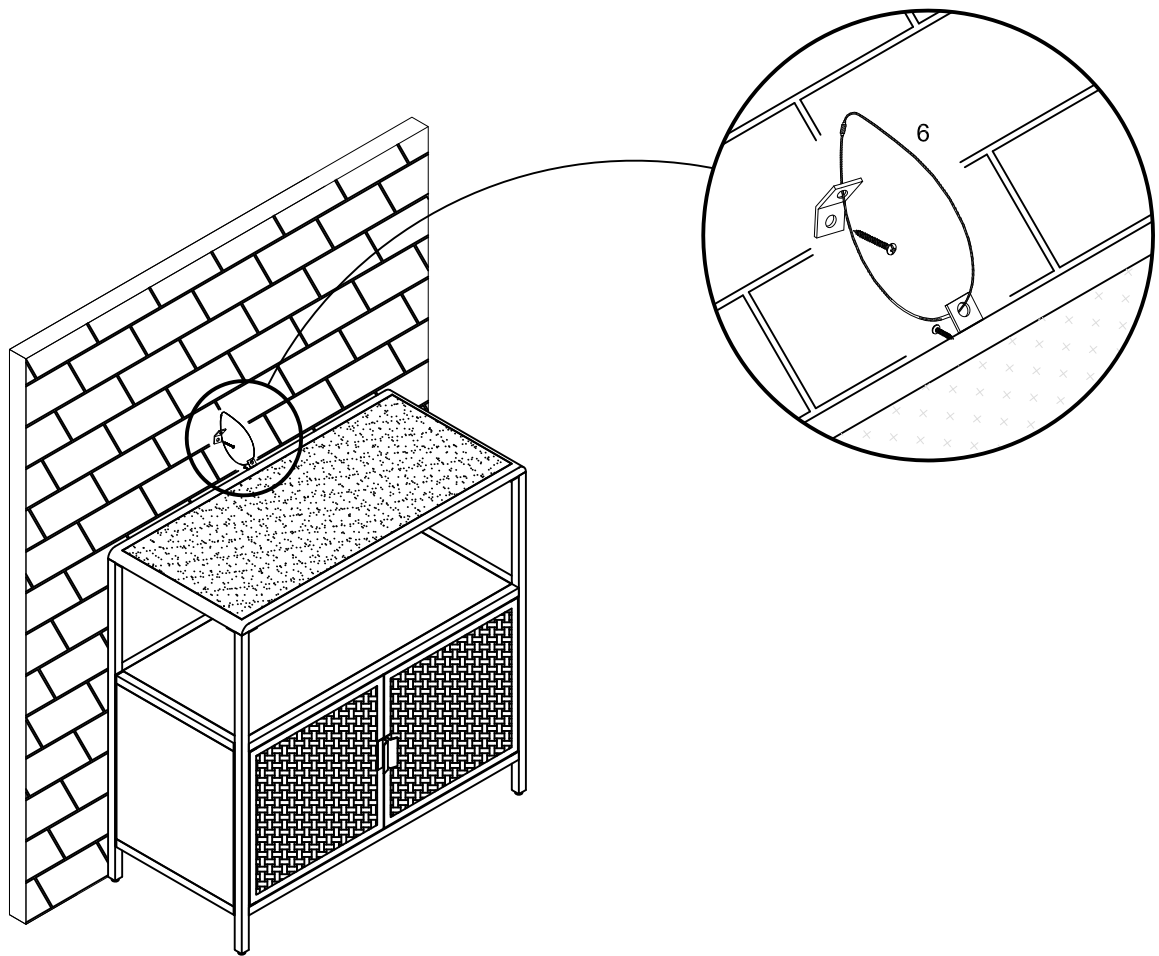
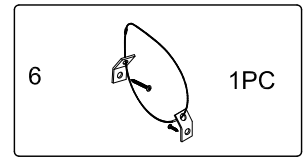

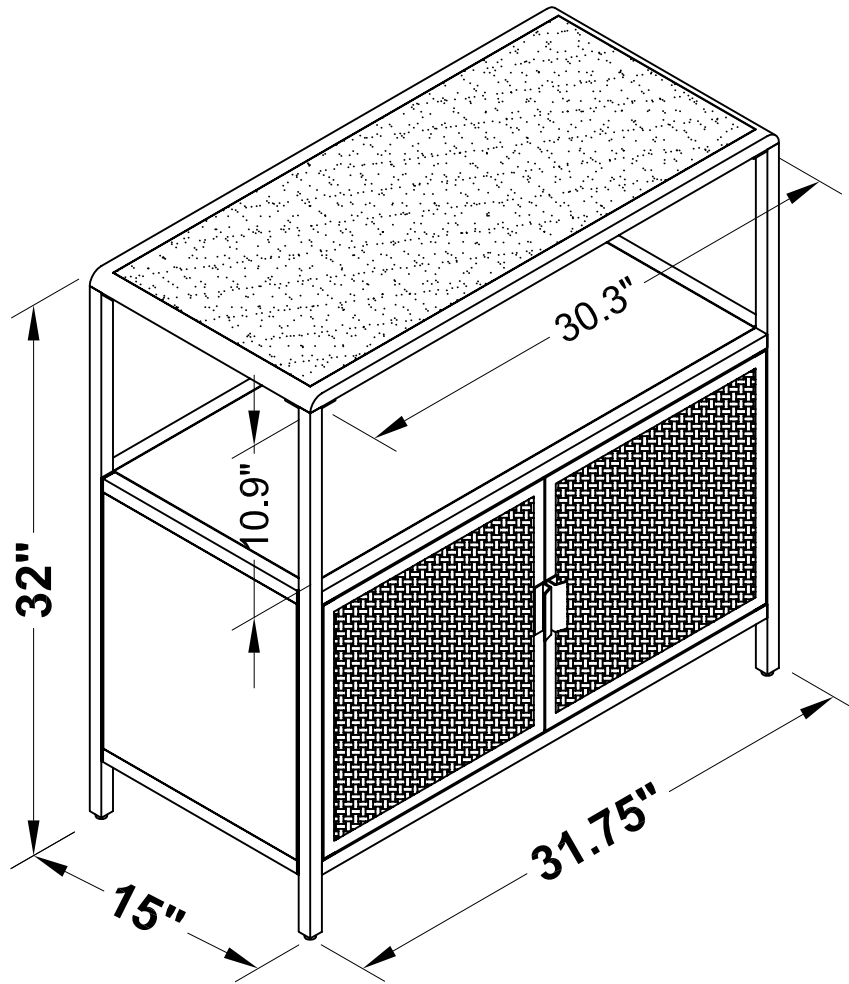

Note : Dimension tolerance $\pm 5\%$