

ASSEMBLY INSTRUCTIONS

THE DOUBLE GARDEN PERGOLA

Before you commence the assembly process we recommend that you read these instructions thoroughly beforehand to familiarise yourself with the assembly process and to also check that you have the correct components. |

We highly recommend that any assembly is carried out on an open flat, level surface if possible with sufficient space. You will also require the assistance of at least 2 adults to complete assembly safely.

Please note: For a free-standing pergola you can remove up to 600mm from the bottom of each post prior to commencing construction.



THE DOUBLE GARDEN PERGOLA



THE DOUBLE GARDEN PERGOLA



Tools required:

10mm socket, No2 Pozidriv screwdriver (or electric driver) , step ladder or platform.

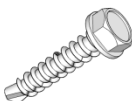
Components

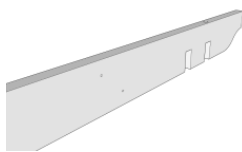
Please Note: The components listed below are those required to build a Double pergola of 3M in size or larger. For the 2.4M version the braces are 150mm shorter, there are only 3 rafters and 14 x 120mm coachscrews.

75mm woodscrews	120mm coachscrews	70mm coachscrews	4 x Pre-drilled outer Rafters
			

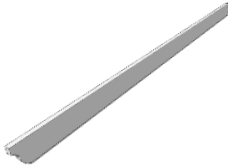
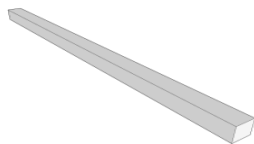
Rafters	Runners – one piece – Scuptled ends	Runners – Split – One square end	Posts
			

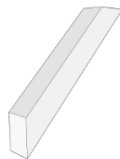
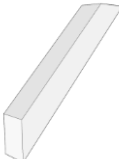
650mm braces	750mm braces
	

The assembly steps that follow are divided into 2 sections. The first section (Page 3) covers the assembly of a **one piece runner** pergola, the second section (Page 8) a **split runner pergola**.

6 post pergolas 4.2 and 4.8M in length are **one piece runner**. All pergolas 5.4M in length and above are **split runner**.

If you have ordered your pergola with a roof slope please refer to the charts below for guidance of the difference in length that you will need to cut your posts to accommodate the slope.

THE DOUBLE GARDEN PERGOLA

If you have ordered your pergola with a roof slope please refer to the charts below for guidance of the difference in length that you will need to cut your posts to accommodate the slope.

5°	
Rafter length (M)	Height diff (mm)
1.8	89
2.4	142
3	194
3.6	246
4.2	299
4.8	351

10°	
Rafter length (M)	Height diff (mm)
1.8	178
2.4	282
3	386
3.6	491
4.2	595
4.8	699

THE DOUBLE PERGOLA

ONE PIECE RUNNER VERSION

Step 1

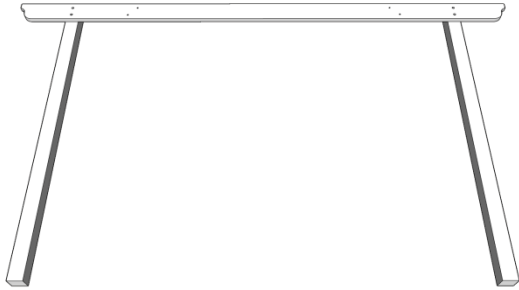

Begin by placing two of the posts on a flat surface as shown and then placing one of the runners, countersinks uppermost, on top of the posts.

Step 2

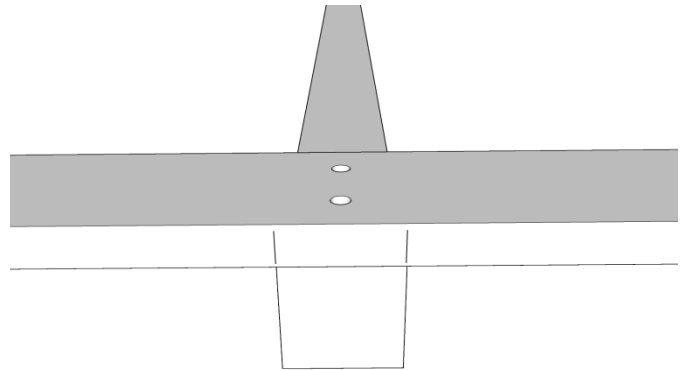

Aligned the top of the post with the lines marked on the top face of the runner and ensure it is also flush with the top edge of the runner and perpendicular to it.

Step 3

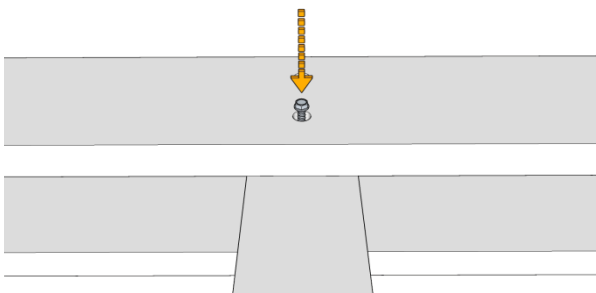

Now insert a 70mm coachscrew into one of the holes in the runner and drive it into the post using a socket and ratchet or driver until almost fully home.

Step 4

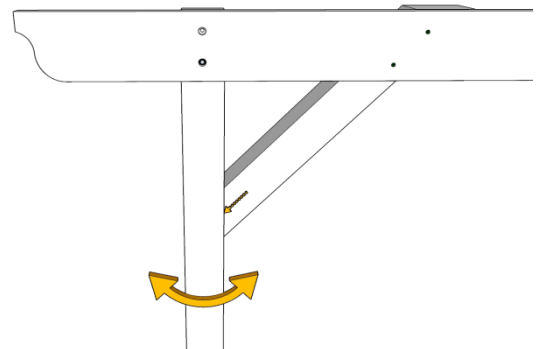

Position one of the braces against the side of the post as shown with the bolt countersink adjacent to the post. Check that the top edge of the brace is flush with the top edge of the runner and that the lower face is flat against the post. If necessary alter the position of the post to achieve this by pivoting it on the bolt inserted in the previous step.

THE DOUBLE PERGOLA

Step 5

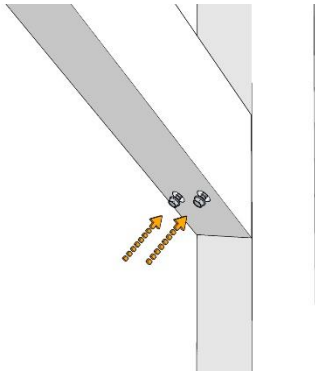

Once the brace is in position insert 2 x 70mm coachscrews and fix it to the post by driving them fully home with the socket.

Step 6

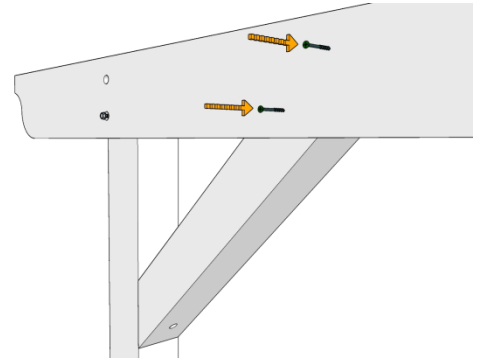

Now secure the other end of the brace to the runner with 2 x green woodscrews.

Step 7

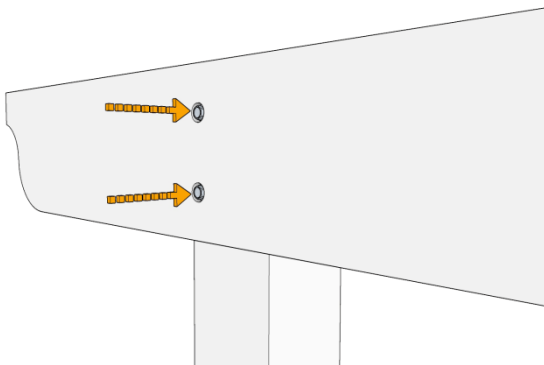

Insert a second 70mm coachscrew into the hole in the runner and drive both coachscrews fully home. Repeat the previous steps and attach the second post to the runner.

Step 8

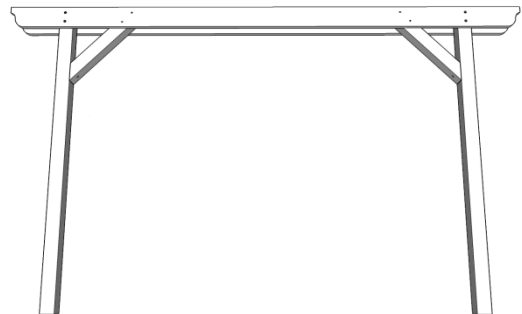

Take the completed assembly and turn it over to commence fitment of the second runner.

THE DOUBLE PERGOLA

Step 9

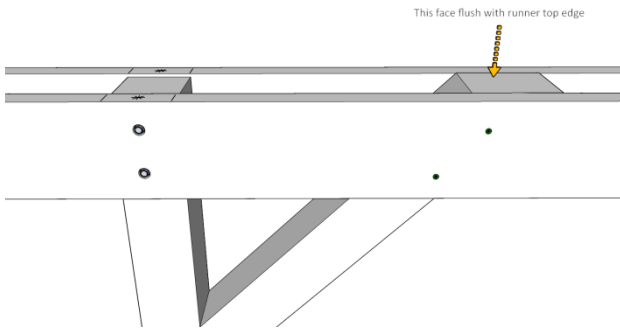

Place the next runner as you did before carefully aligning it before attaching to the post and brace as before.

Step 10

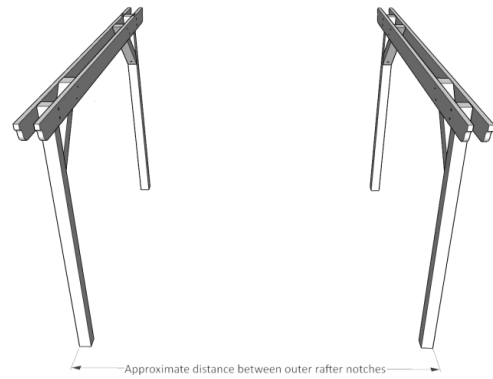

Repeat steps 1 - 9 so that you now have two frame assemblies. Arrange them both near to the pergola's intended final location, as shown above, spacing the posts apart by the approximate distance between the outer rafter notches.

Step 11

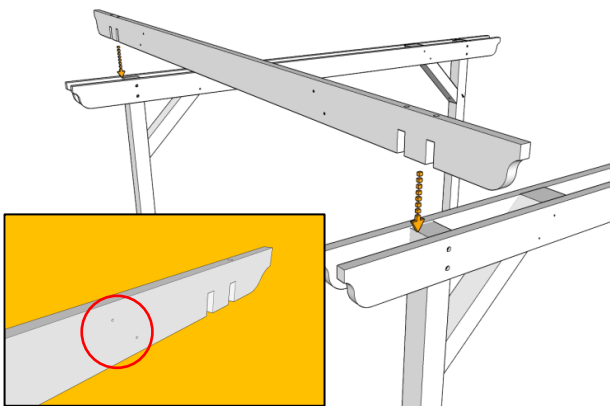

Now take one of the pre-drilled rafters and lower it onto the 2 frame assemblies so that the notches in the rafters and runners interlock and fully house. **Tip:** You may need to adjust the positioning of the frames in relation to each other to get everything square and true for this and the following stage.

Step 12

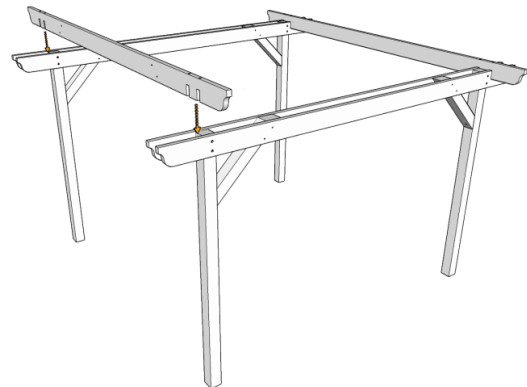

Drop a second pre-drilled rafter into place at the other end of the assembly.

THE DOUBLE PERGOLA

Step 13

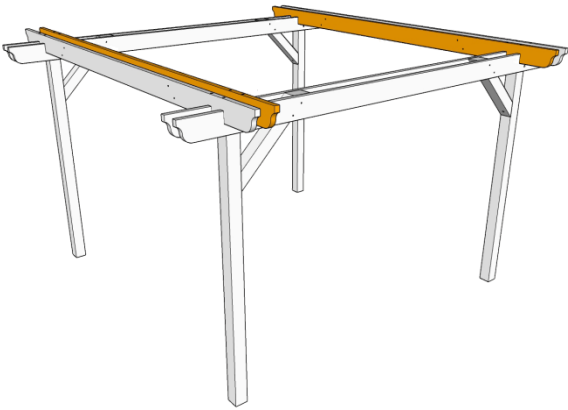

Now insert the remaining pre-drilled rafters adjacent to the rafters inserted previously.

Step 14

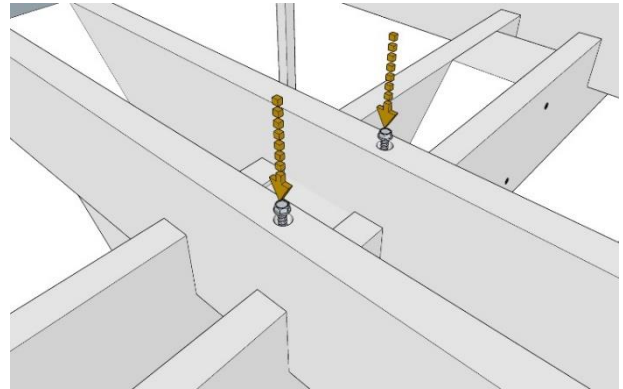

With the pre-drilled rafters now in place affix secure them with a pair of 120mm coachscrews driven through each end.

Step 15

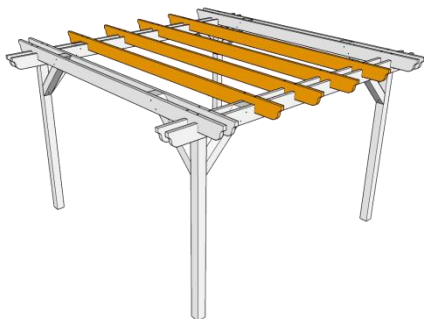

Now insert any remaining rafters using the lines marked on the top face of the runner to space them correctly...

Step 16

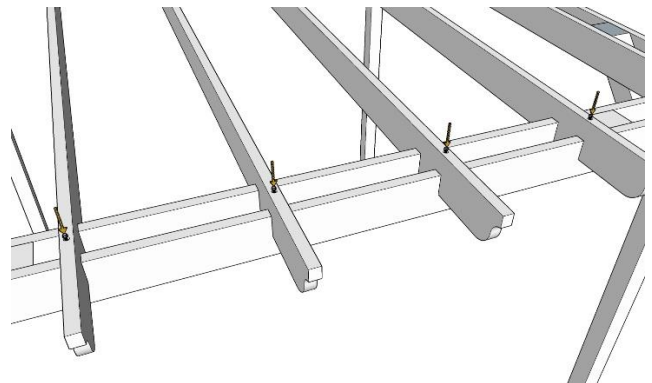

...before securing them with a 120mm coachscrews driven into each end of the rafter.

THE DOUBLE PERGOLA

Step 17

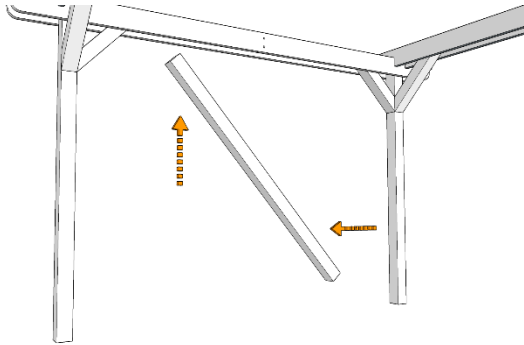

If you are building a 3-post version take the intermediate post and manoeuvre it into position by sliding it between the runners as shown...

Step 18

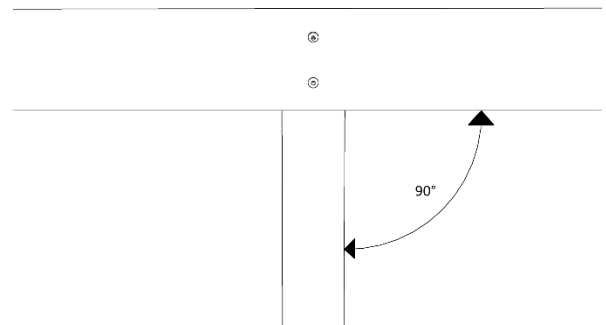

Line the post up with the centre post marks on the runner, then use a spirit level to make sure the post is vertical and at 90° to the runner before fixing into place with 2 x 70mm coachscrews through each runner.

Step 19

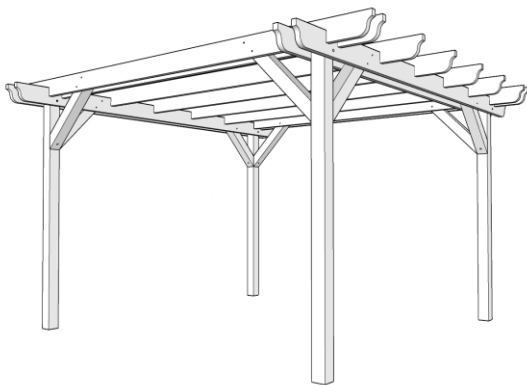

Your Double pergola is now complete. If you have selected the optional cladding kit please see step 20.

Step 20

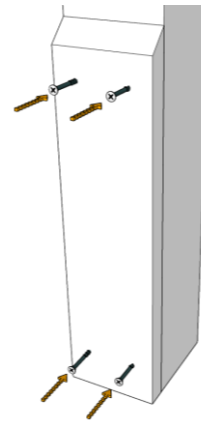

To attach cladding panels simply align as shown at the base of the post before screwing into place using 4 x green woodscrews through the pre-drilled holes per panel. Repeat for each face of the post.

THE DOUBLE PERGOLA

SPLIT RUNNER VERSION

Step 21

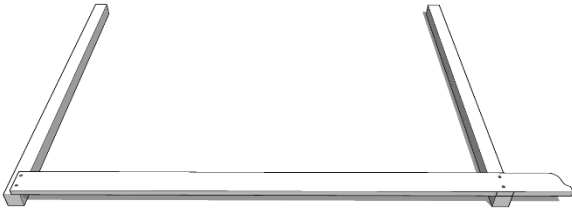

Begin by placing two of the posts on a flat surface as shown and then placing one of the runners, countersinks uppermost, on top of the posts.

Step 22

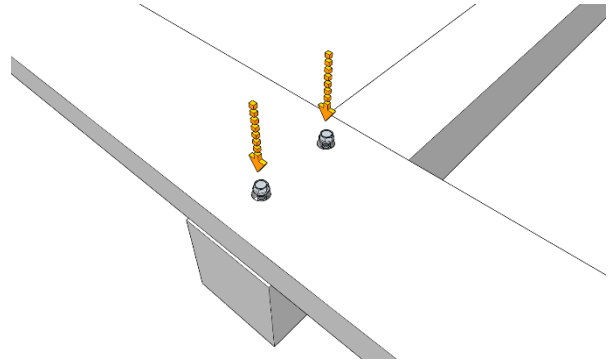

Now insert a pair of 70mm coachscrews into the countersunk holes at one end of the runner and drive them into the post using a socket and ratchet or driver until almost fully home.

Step 23

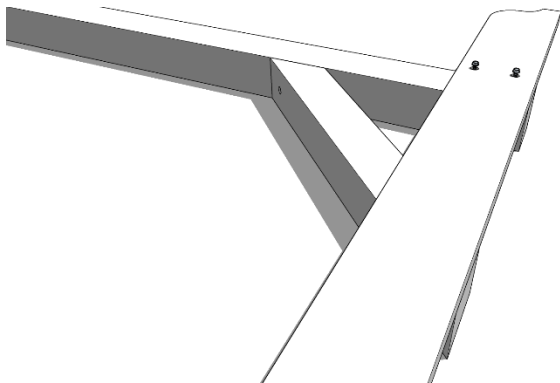

Position one of the 650mm braces against the side of the post as shown with the bolt countersink adjacent to the post. Check that the top edge of the brace is flush with the top edge of the runner and that the lower face is flat against the post. If necessary alter the position of the post to achieve this by pivoting it on the bolts inserted in the

Step 24

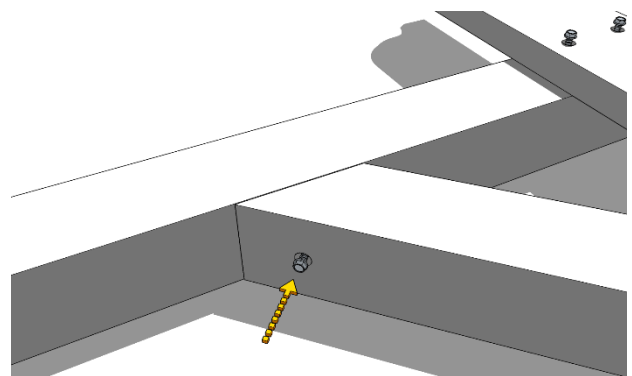

Once the brace is in position insert a 70mm coachscrew and fix it to the post by driving it fully home with the socket.

THE DOUBLE PERGOLA

Step 25

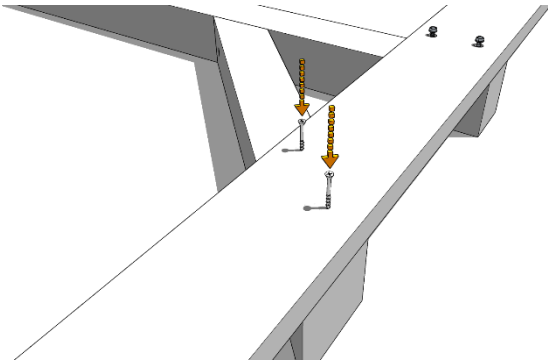

Secure the other end of the brace to the runner with 2 x green woodscrews. Fully tighten down the 2 coachscrews into the post.

Step 26

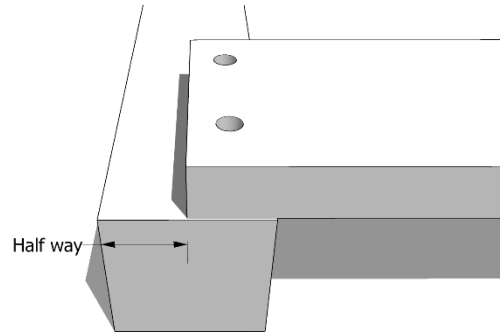

Carefully align the next post at the other end of the runner as shown, so that the runner is halfway across the face of the post (approximately 47mm) before repeating Steps 22-25 to complete...

Step 27

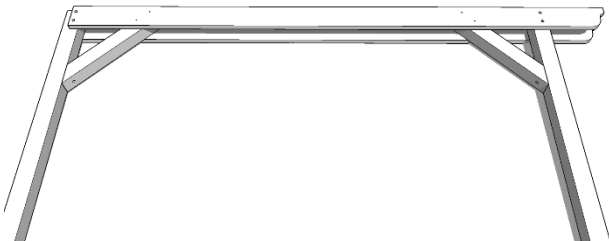

... before flipping the assembly over and adding another runner to complete the first "Goalpost" structure as shown here. Repeat Steps 21-26 to complete another identical structure.

Step 28

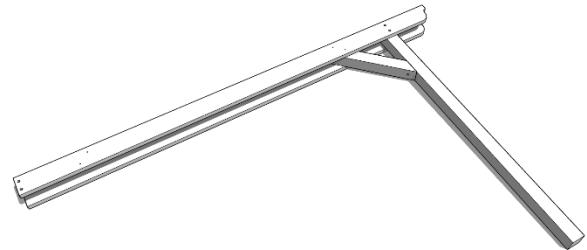

Now use the remaining runners, posts and 650mm braces, construct 2 single post, partial "Goalposts" using the same methods outlined in Steps 22-27.

THE DOUBLE PERGOLA

Step 29

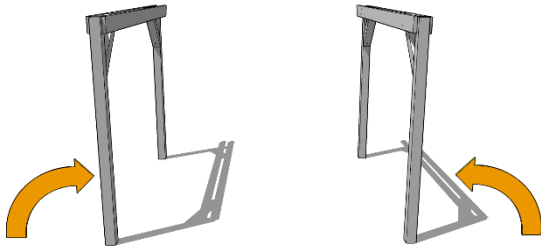

Arrange the two completed goalpost structures at the pergola's intended final location as shown above, spacing the posts apart by the approximate distance between the outer rafter notches.

Step 30

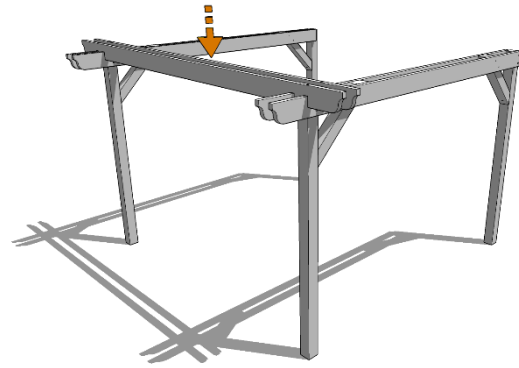

Now take a pair of the Outer pre-drilled rafters and lower them onto the 2 frame assemblies so that they butt up to either side of the post. **Tip:** You may need to adjust the positioning of the frames in relation to each other to get everything square and true for this and the following stage.

Step 31

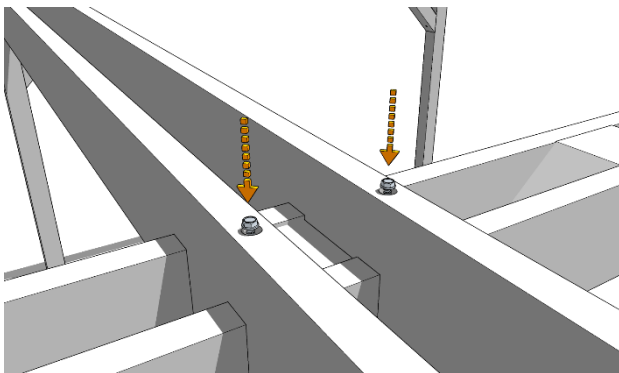

Once everything is in position, secure each end of the rafters in place with a 120mm coachscrew, driven down into the runner.

Step 32

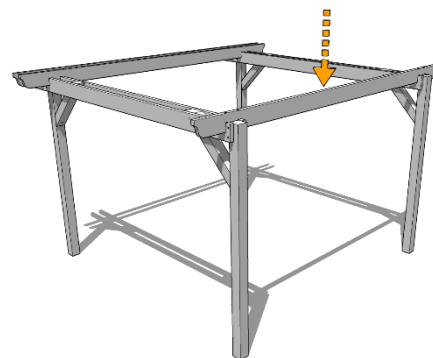

Now drop a plain rafter into place at the other end of the assembly so that it butts up against the inner face of the posts, before securing each end in place with a 120mm coachscrew.

THE DOUBLE PERGOLA

Step 33

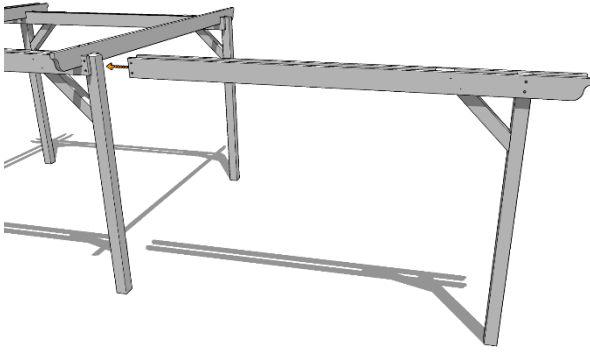

Add one of the partial "Goalpost" assemblies to the structure...

Step 34

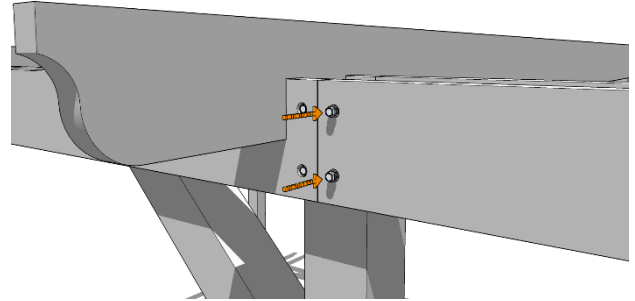

...sliding the two runner ends so that they meet the existing runners before securing with 2 x 70mm coachscrews driven through each runner into the post.

Step 35

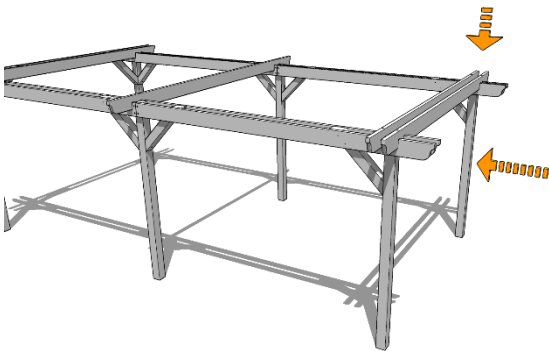

Add the second partial "Goalpost" to the structure, securing it in place as with 4 x 70mm coachscrews, before adding the remaining pair of Outer pre-drilled rafters and attaching them with 4 x 120mm coachscrews as before.

Step 36

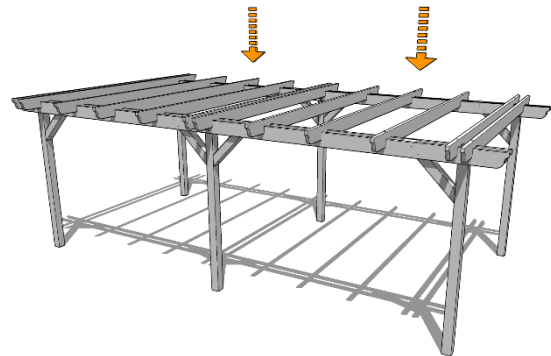

Add any remaining rafters using the marks on the runner top edges, securing them with a 120mm coachscrew at each end.

THE DOUBLE PERGOLA

Step 37

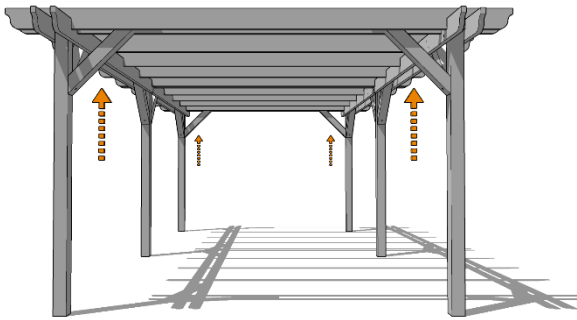

The final step is to add the 750mm braces to the four corners. Slide these up between the outer rafters so that the top edge is flush with the top of the rafter and the lower face butted up against the post before securing each one in place with a 70mm coachscrew into the post and a pair of 70mm wood screws through the rafter into the brace.

Step 38

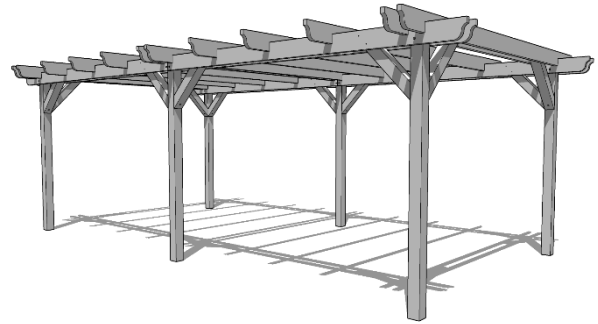

Your Double pergola (Split runner) is now complete. If you have selected the optional cladding kit please see step 20.

WE HOPE THAT YOU FOUND YOUR PRODUCT QUICK AND EASY TO ASSEMBLE