

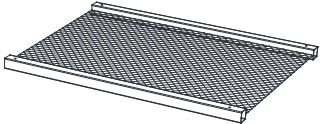



**! "IMPORTANT, RETAIN FOR FUTURE REFERENCE: READ CAREFULLY"**

1. Gather and organize all required parts prior to assembly.
2. Assemble on a flat, clean and soft surface.

Item no.	Reference Image	Qty.	Item no.	Reference Image	Qty.
<b>A</b>		X1	<b>C</b>		X2
<b>B</b>		X2	<b>D</b>		X4
			<b>E</b>		X1
				spare part	

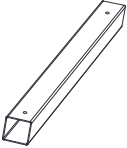
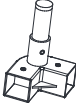
1. Loosen and open the L-connector screws A with Allen key.

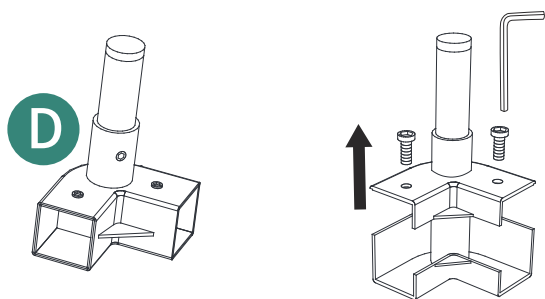

2. Insert 2 part C metal strips.

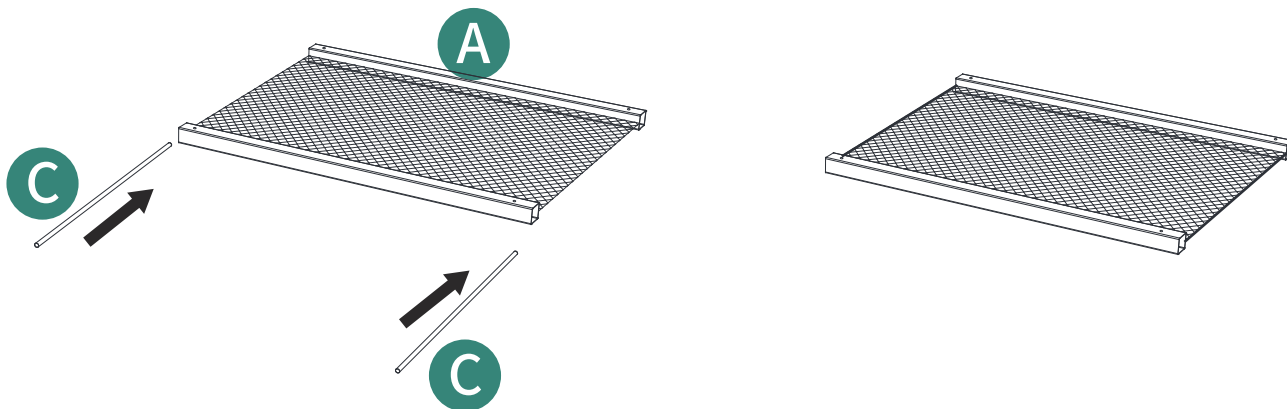

3. Insert the two shorter sides of the Tesline mesh into both part B aluminum bars. using the tube slots as shown.

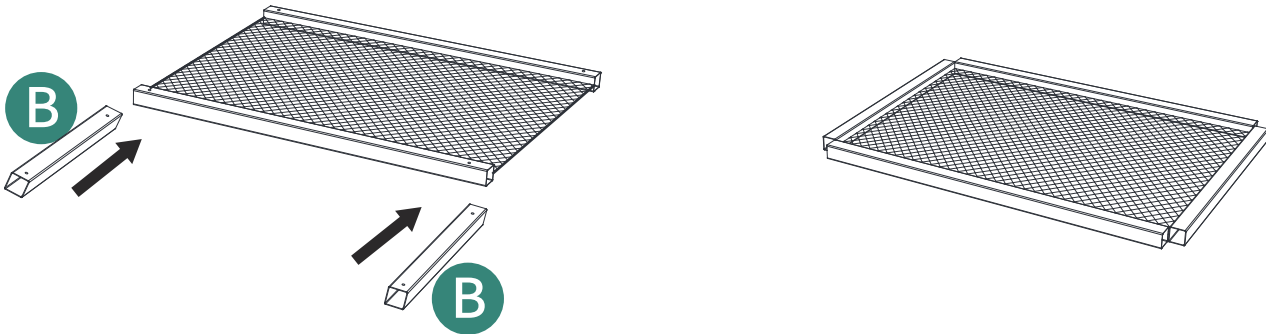

4. Attach and align the two L-connectors into the bed's corners, then tighten the screws.

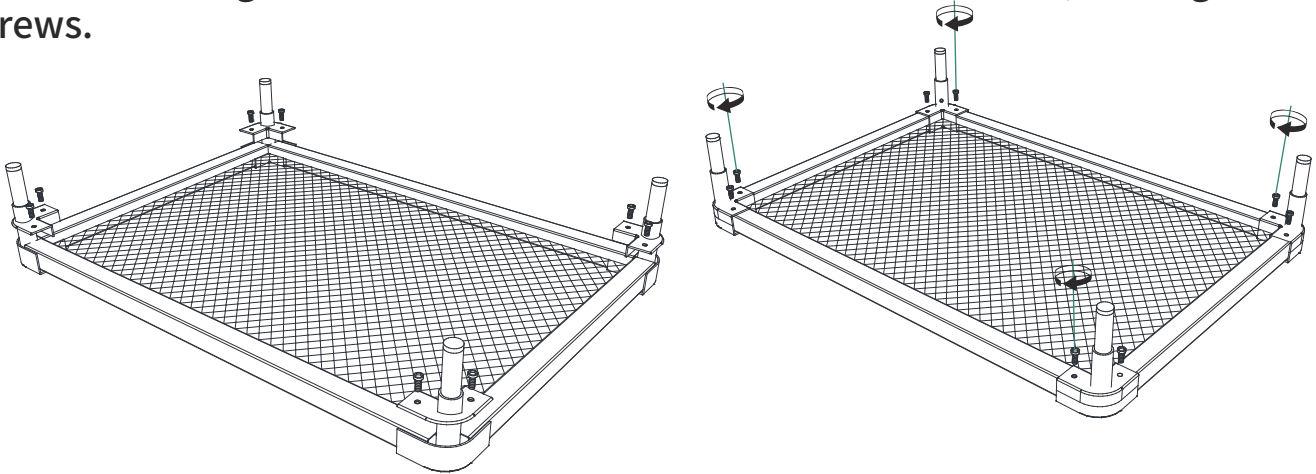

5. Attach and align the third L-connectors (Do not tighten the screws), then align L-connectors with last bed's corner. Last, tighten all screws of the 2 corners.

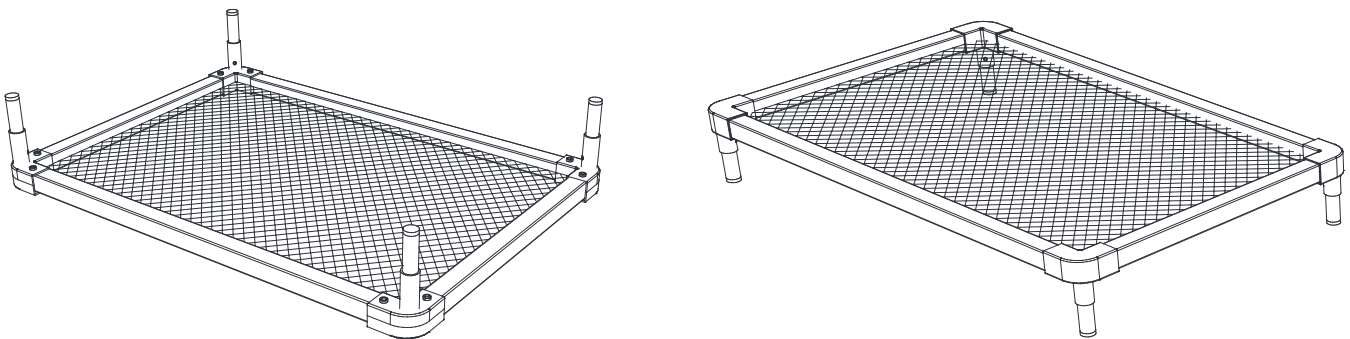

Installation Completed