

STORAGE BOX

There is no need to return your furniture set.
Contact us for after-sale service!

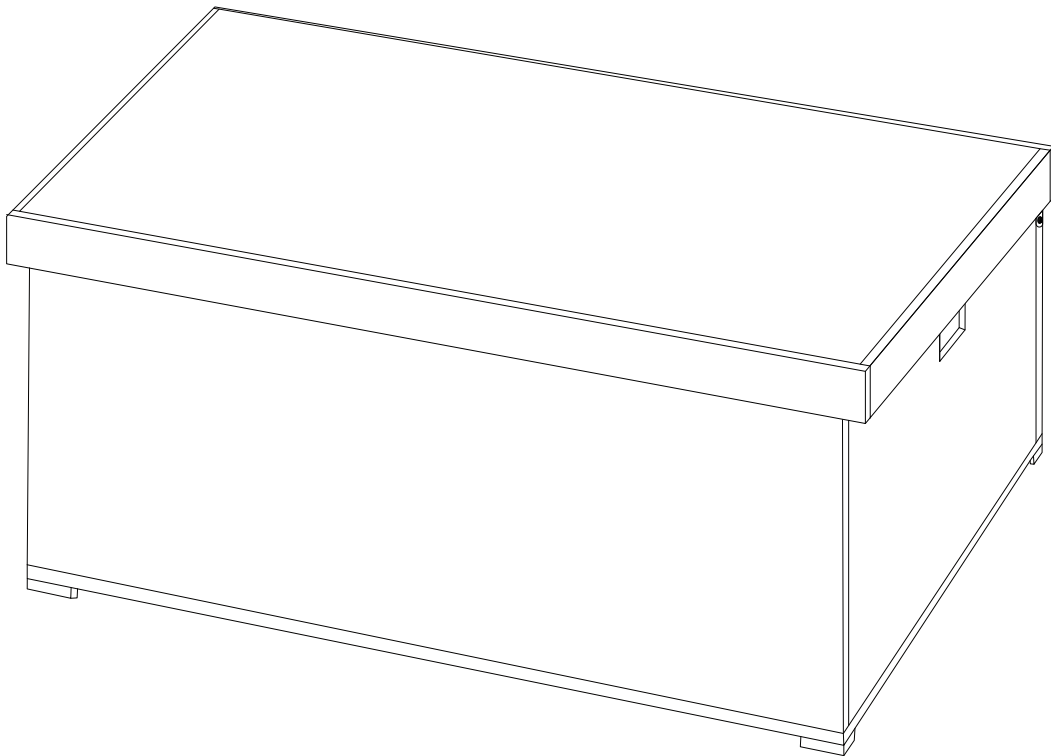

After-sales mailbox:
Patiofurniture Serviceteam@outlook.com

NOTICE

Please keep these instructions for future reference.

Dear Customer

- Thank you for your purchase. When you receive the product, please make sure that all the parts are intact. Then follow the entire installation instructions to install!
- There is an installation video on the product page, you can open the product page to view it or contact customer service to receive it.

- A . The outer box is damaged
- B . The product is damaged / bent / cracked while you open the box
- C . The parts / accessories / assembly tools are missing
- D . The instructions are not clear and can not be referred
- E . The product has functional problems
- F . Other aspects that you are not satisfied with

Please feel free to contact us for help. Our after-sales team service

(Patiofurniture Serviceteam@outlook.com) will reply within 24 hours and will do our best to resolve the problem for you.



PART LIST

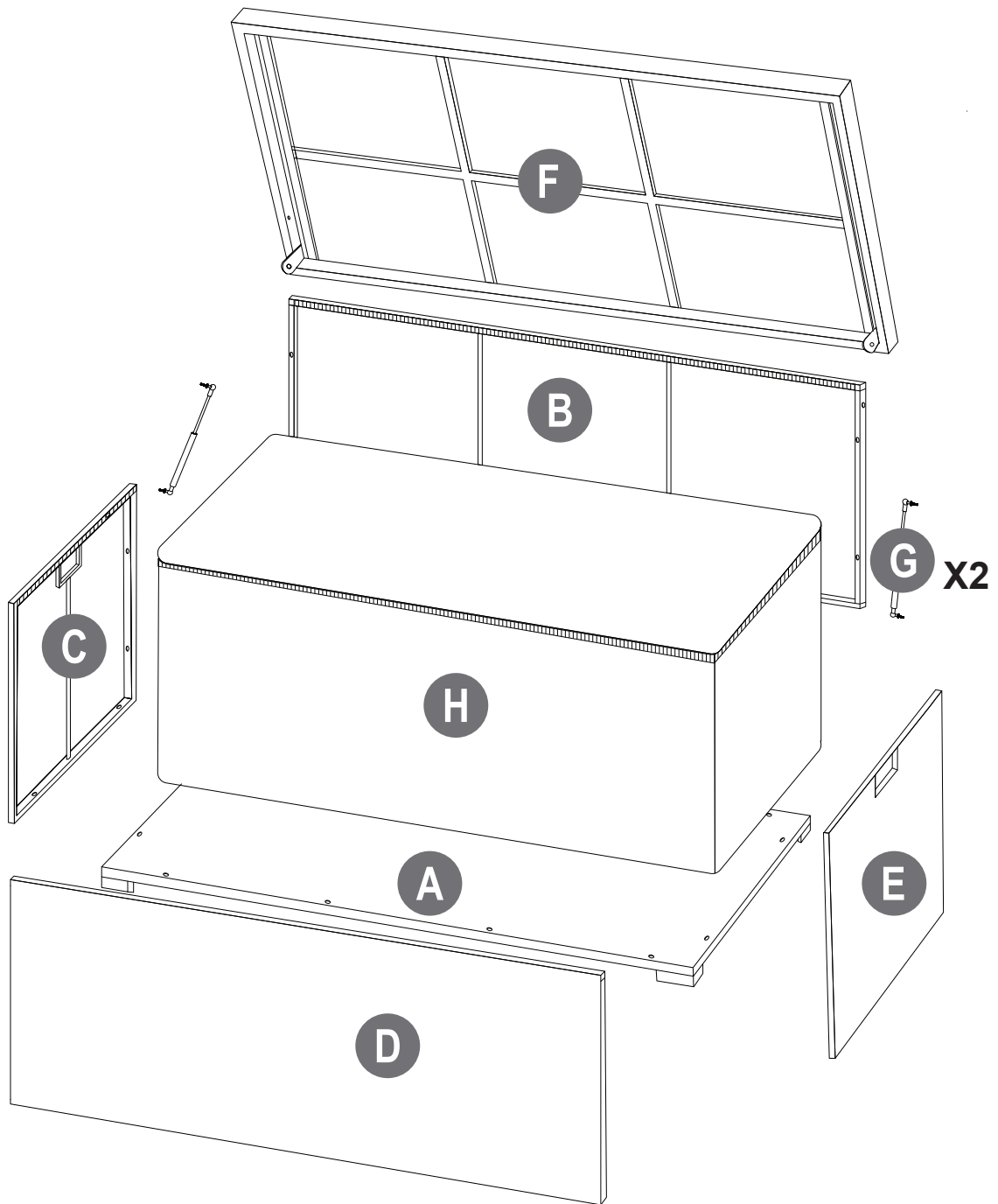

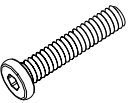
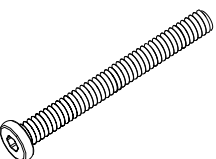
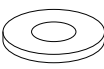
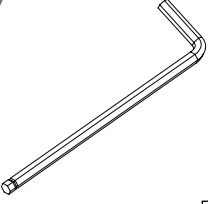
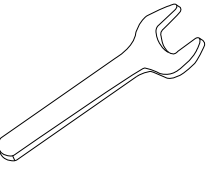
<p>1</p>  <p>M6*20MM</p> <p>x 2</p>	<p>2</p>  <p>M6*35MM</p> <p>x 20</p>	<p>3</p>  <p>x 22</p>	<p>4</p>  <p>x 1</p>
<p>5</p>  <p>x 1</p>			

STEP

1

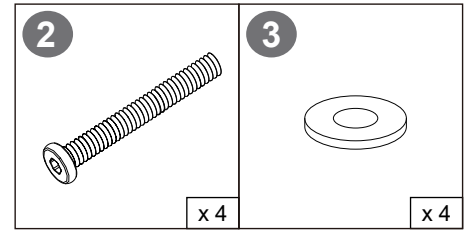

To install, place the base plate (part A) on a level surface.

(Tips: The smooth side of the base plate (part A) faces up, Side Plate (Part B) smooth side facing out, Velcro end facing up).

Stellen Sie die Grundplatte (Teil A) auf eine ebene Fläche.

(Tipps: Die glatte Seite der Grundplatte (Teil A) zeigt nach oben, Die glatte Seite der Seitenplatte (Teil B) zeigt nach außen, das Klettverschlussende nach oben.)

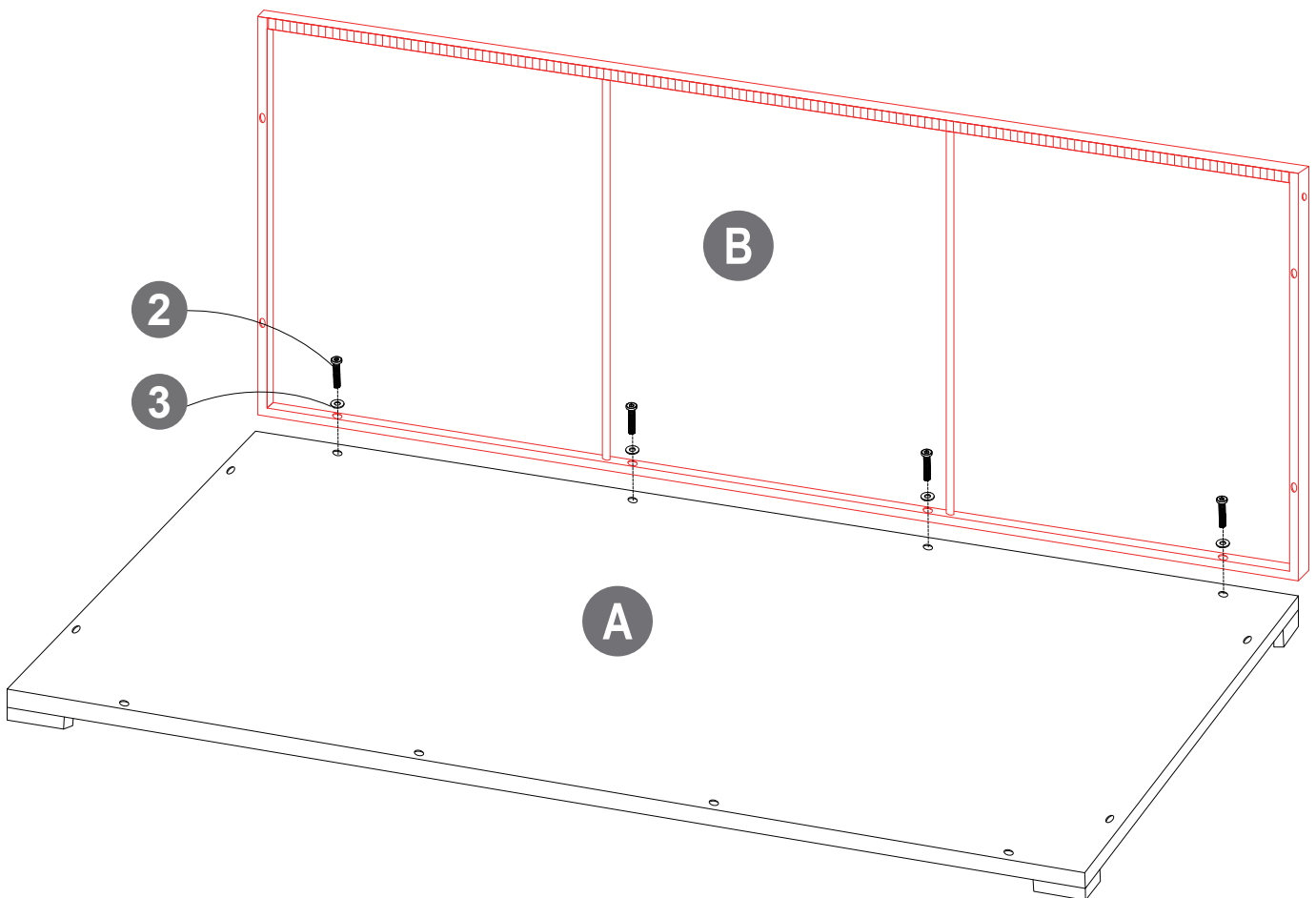

3

STEP

2

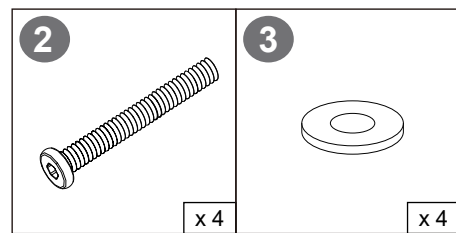

Mounting Side Plate (Part D)

(Tips: The smooth side of the side panel (part D) faces out and the velcro end faces up.)

Montage der Seitenplatte (Teil D)

(Tipps: Die glatte Seite des Seitenteils (Teil D) zeigt nach außen und die Klettseite zeigt nach oben.)

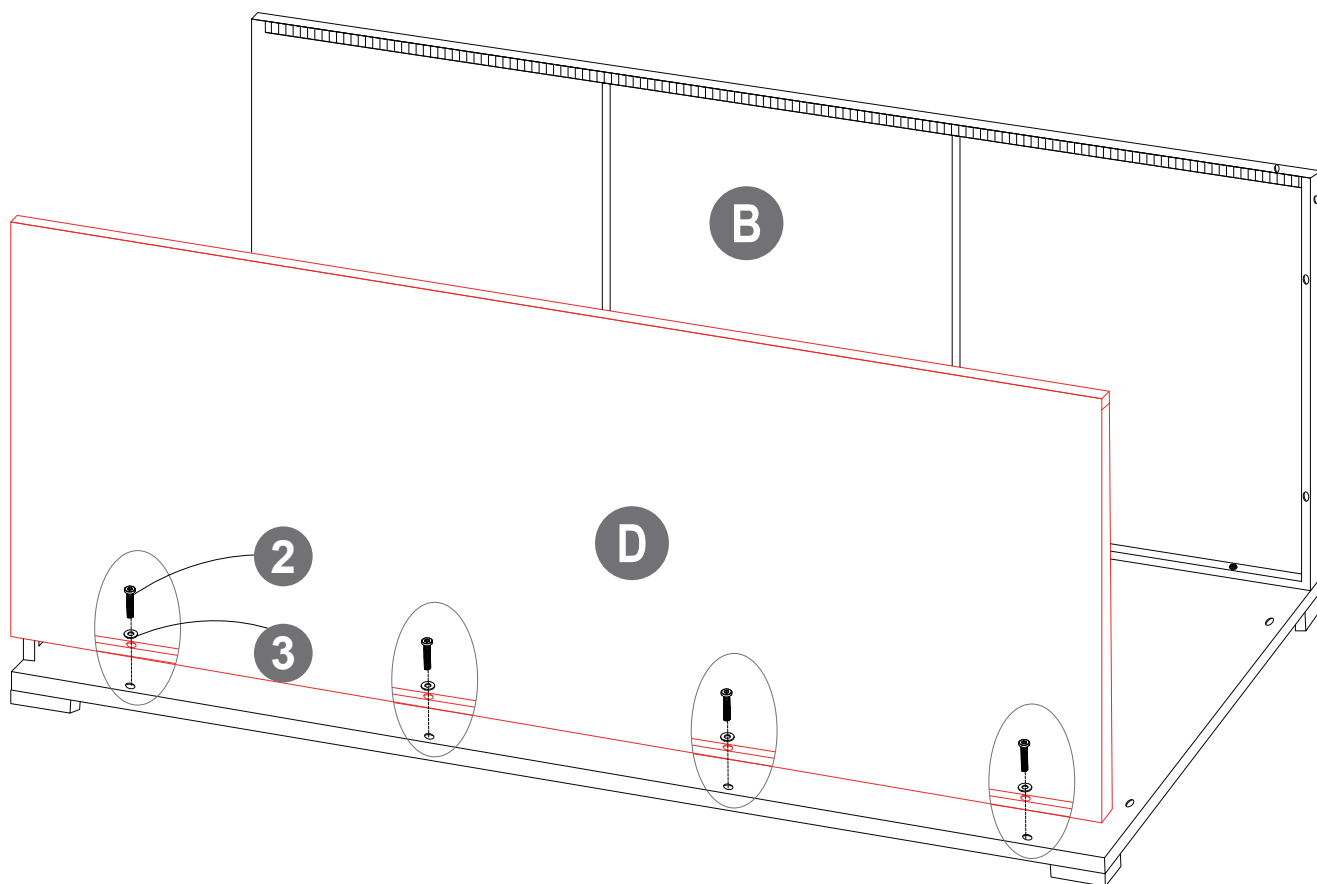

STEP

3

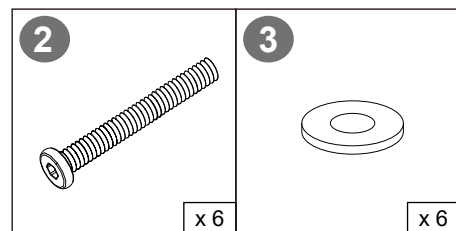

Align the end plate (part C) with the holes in the base plate (part A) and side plates (parts B and D).

(Tips: End plate (part C) smooth side facing out, velcro end on top.)

Richten Sie die Endplatte (Teil C) auf die Löcher in der Grundplatte (Teil A) und den Seitenplatten (Teile B und D) aus.

(Tipps: Endplatte (Teil C) glatte Seite nach außen, Klettverschluss nach oben.)

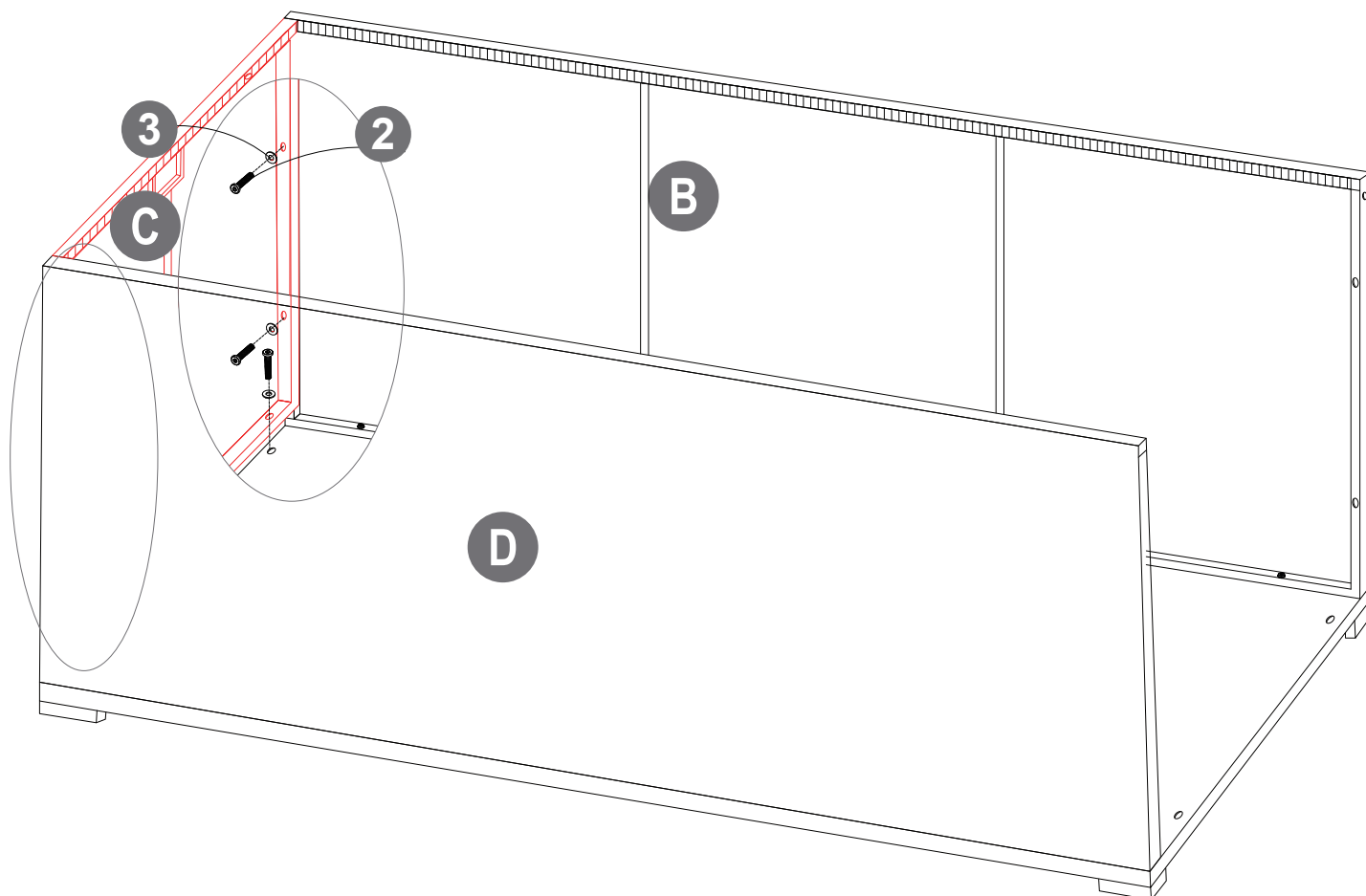

STEP

4

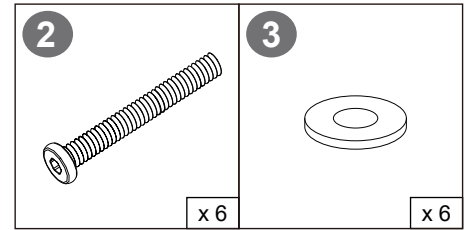

Align the end plate (part E) with the holes in the base plate (part A) and side plates (parts B and D).

(Tips: The smooth side of the end plate (part E) faces outward with the Velcro end on top.)

Richten Sie die Endplatte (Teil E) an den Löchern in der Grundplatte (Teil A) und den Seitenplatten (Teile B und D) aus.

(Tipps: Die glatte Seite der Endplatte (Teil E) zeigt nach außen, das Klettverschlussende liegt oben.)

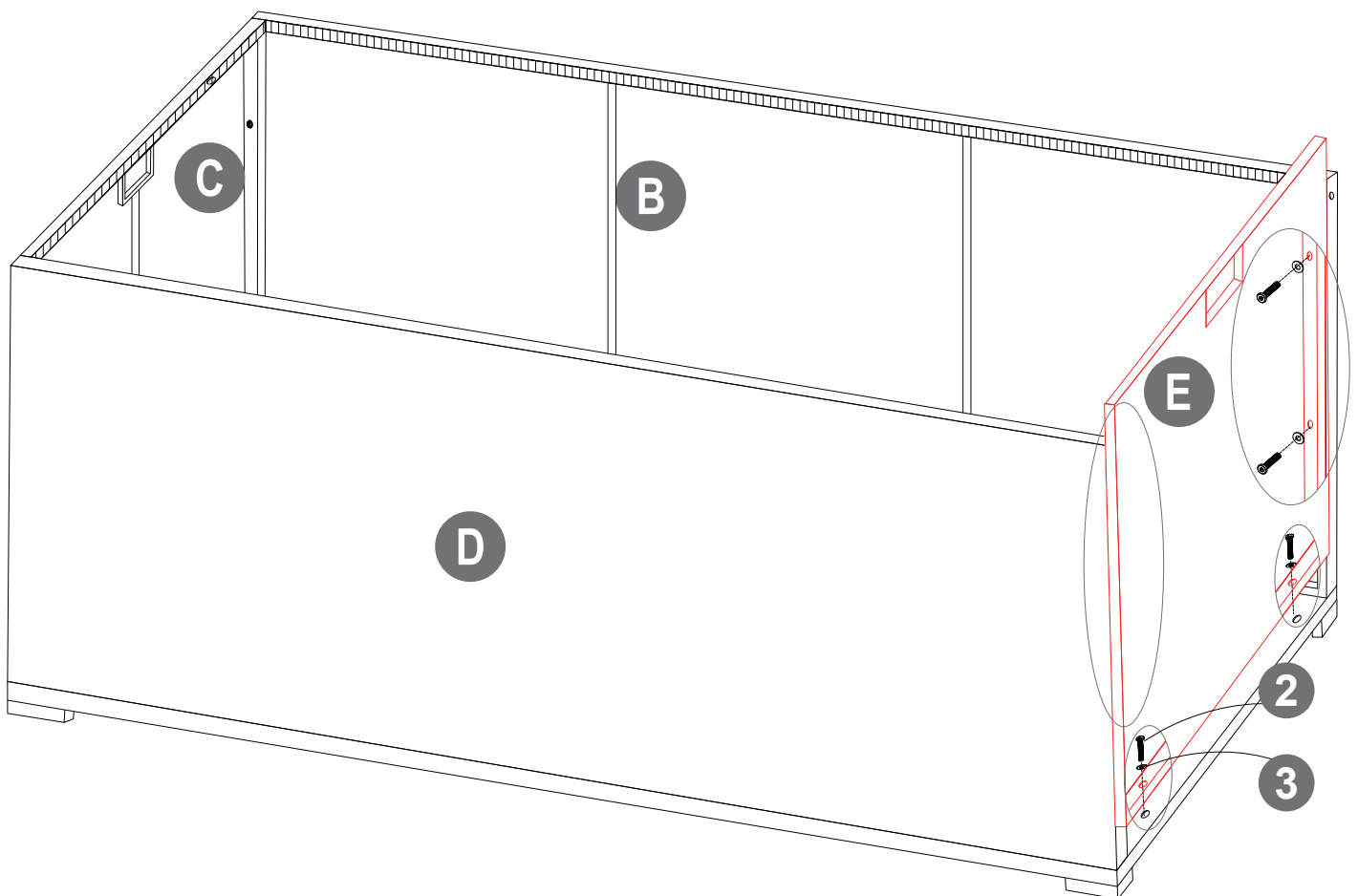

STEP

5

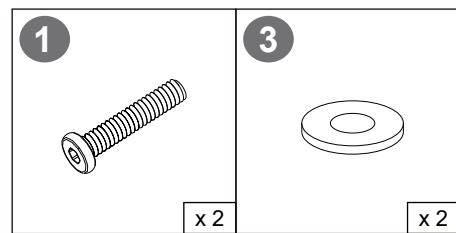

Align the cover plate (part F) with the outer holes of the side plate (part B).

(Tips: There is one hole on each side of the side panel (part B) and no holes in the side panel (part D).)

Richten Sie die Abdeckplatte (Teil F) an den äußeren Löchern der Seitenplatte (Teil B) aus.

(Tipps: Es gibt ein Loch auf jeder Seite der Seitenwand (Teil B) und keine Löcher in der Seitenwand (Teil D).)

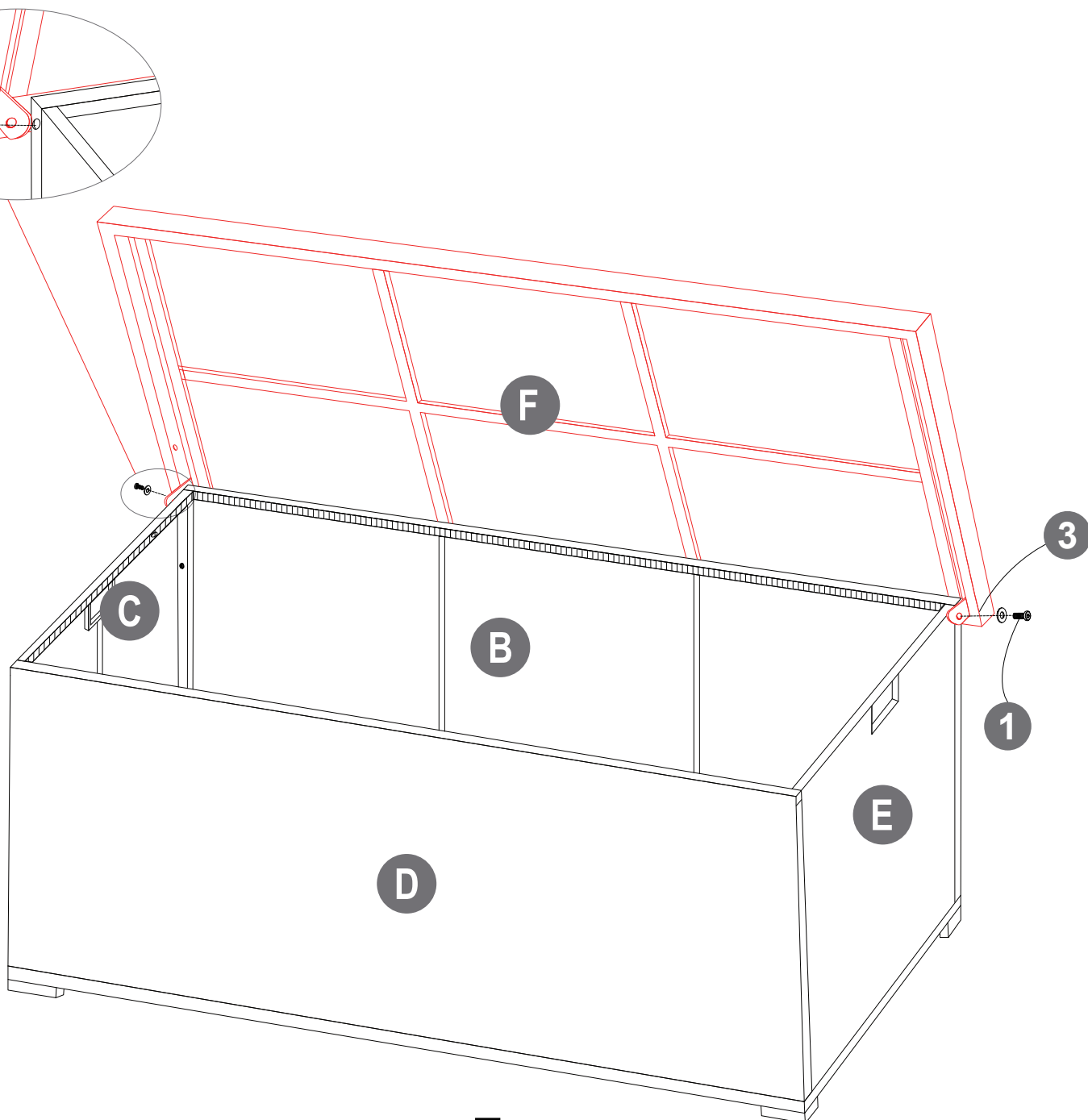

STEP

6

Align gas spring (part G) with holes in cover plate (part F) and end plates (parts C and E).
(Tips: The screws for the gas springs need to be screwed into the holes.)

Richten Sie die Gasfeder (Teil G) auf die Löcher in der Abdeckplatte (Teil F) und den Endplatten (Teile C und E) aus.
(Tipps: Die Schrauben für die Gasfedern müssen in die Löcher geschraubt werden.)

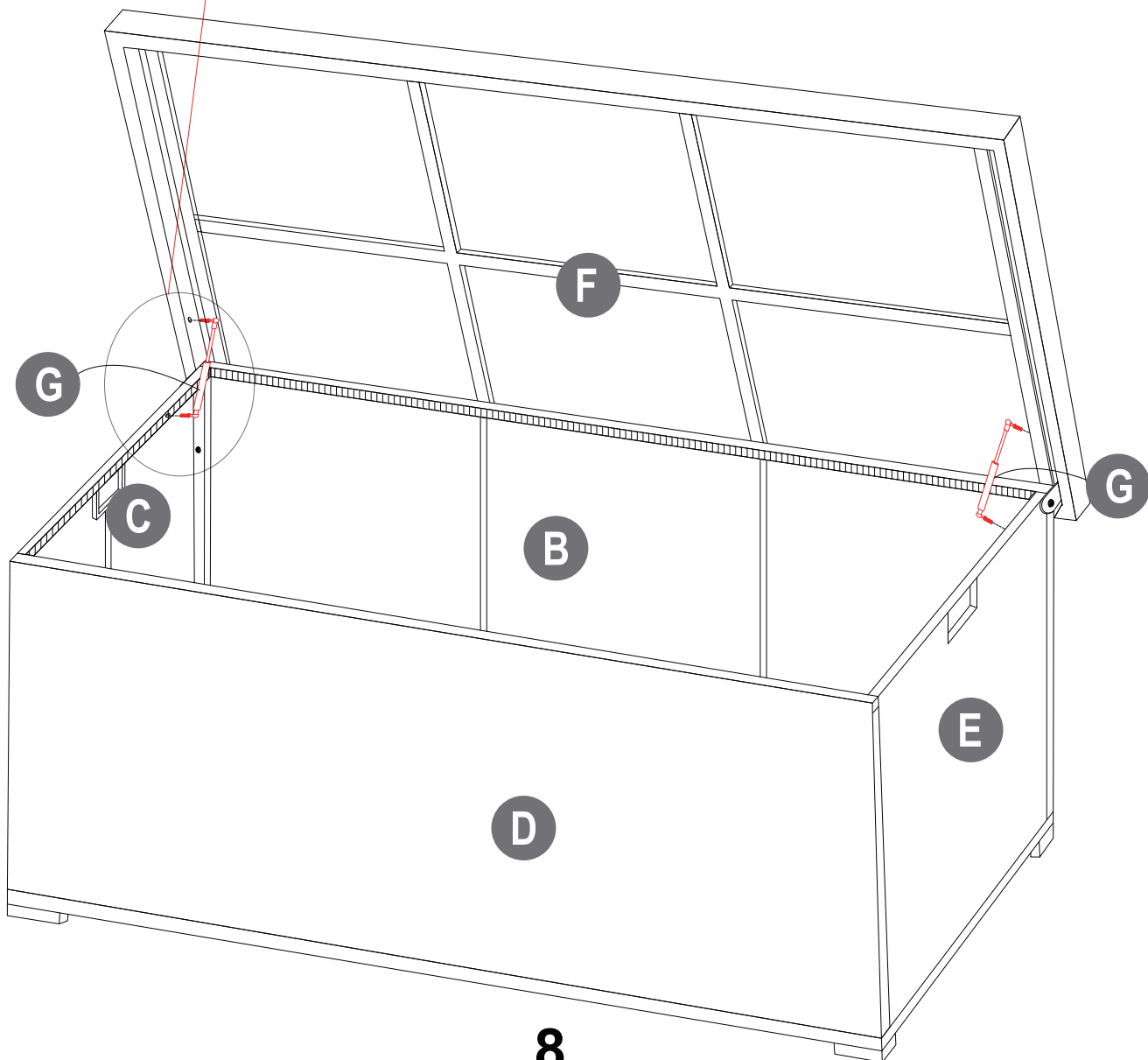
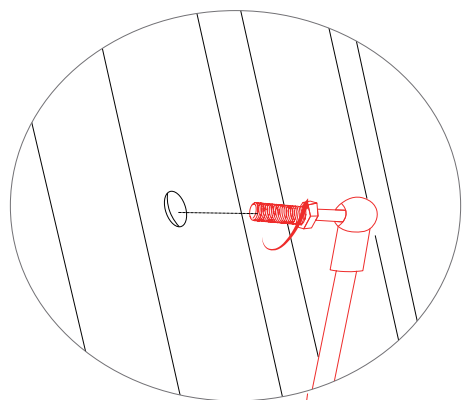

8

STEP

7

(Tips: Unfold the tarpaulin cover (part H) with the Velcro end facing out and place it into the box, locking it together with the Velcro at the top of the side panels and end panels.)

(Tipps: Falten Sie die Plane (Teil H) mit der Klettseite nach außen auf und legen Sie sie in die Box, indem Sie sie mit den Klettverschlüssen oben an den Seiten- und Stirnwänden befestigen.)

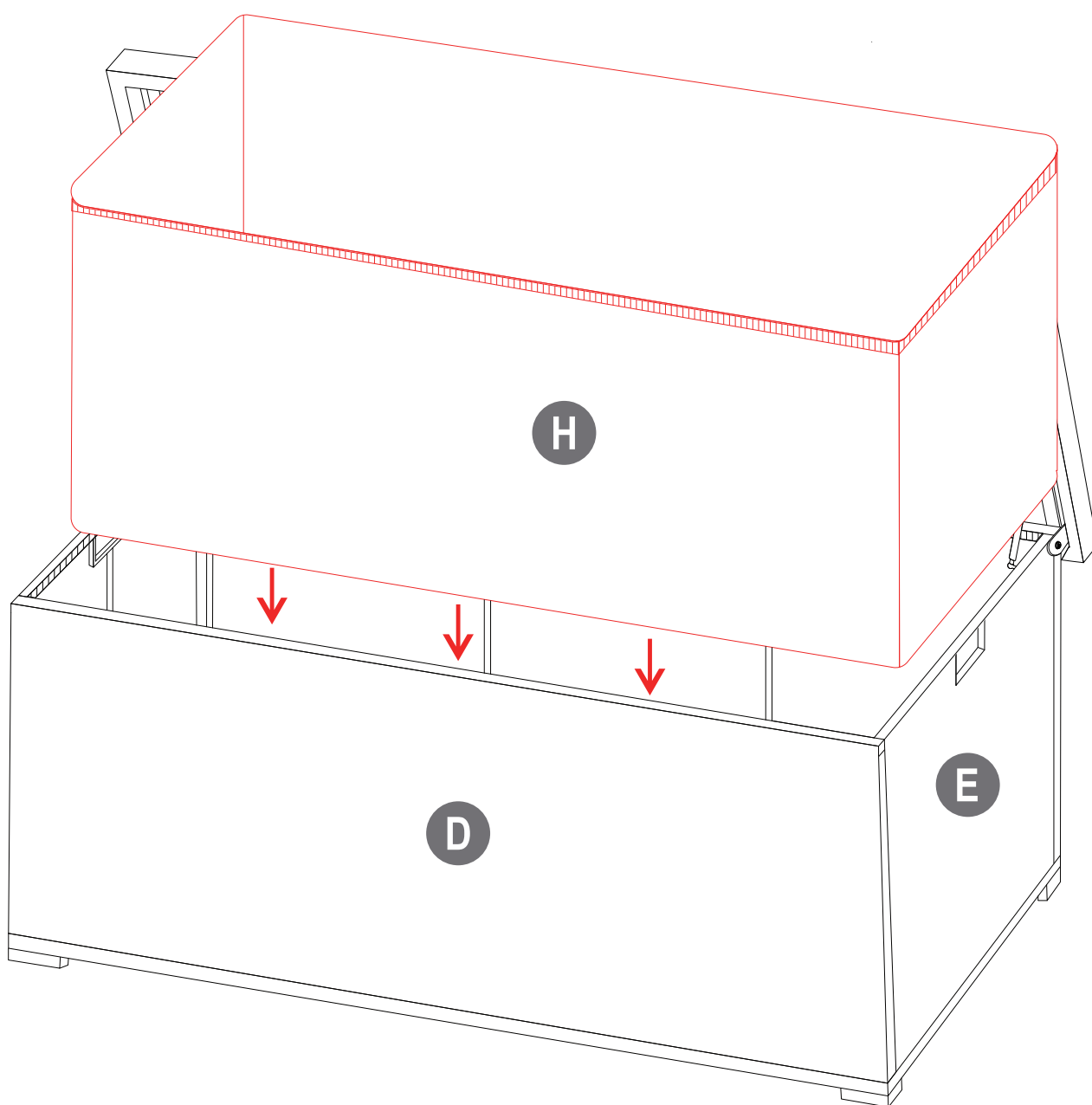

STEP

8

Complete the installation

Beenden Sie die Installation

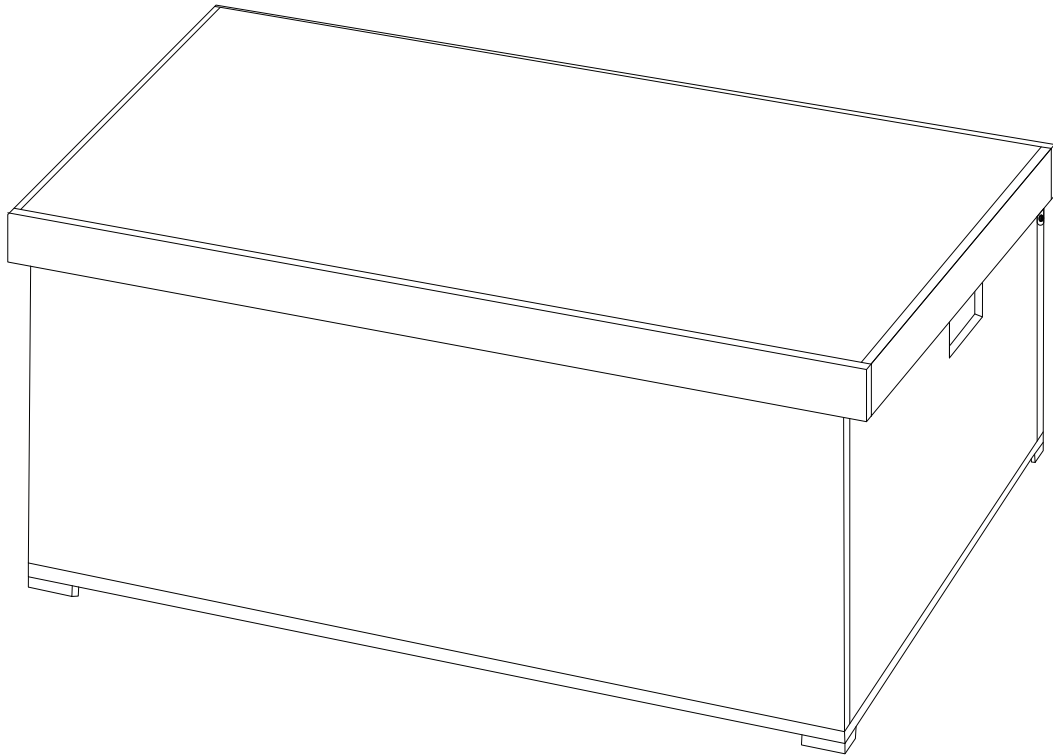

AFTER-SALE SERVICE

If you have any suggestions for our products or find that the products have quality problems, please contact us first, our after-sales team will reply you within 24 hours, and we will do our best to give you solutions until you are satisfied.

Guaranteed Customer Service

Your shopping experience is very important to us!
Feel unsatisfied? **Contact us!**
Have any questions? **Contact us!**

Wanna Share how wonderful our smart promakes your home?
Share your pictures with us.
Any suggestions? **Contact us!**
We gotcha back!



Patiofurniture Serviceteam@outlook.com

