

ASSEMBLY INSTRUCTION



IMPORTANT NOTICE

INSTALLATION GUIDE

tools required: allen wrenches(provided)

ASSEMBLY REQUIREMENT

1. Remove all packaging materials, staples and packing straps from the carton.
2. Refer to Parts Checklist and ensure they are complete before you start assembling.

TIPS FOR ASSEMBLY







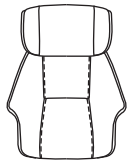
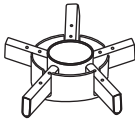
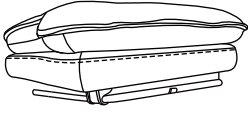

1. Allow ample room for assembly and in close proximity to where product will be placed.
2. Assemble the product on a surface that does not scratch or damage the exterior and finish of the furniture.
3. During assembly, do not over-tighten any fittings as this may cause damage.
4. Do not use power tools to assemble this product.
5. Do not sit or stand on the partially assembled product, use only installed products.

CARE AND USE



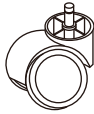

- Recommended for indoor and residential use only.
- Wipe with a soft, dry cloth. Do not use harsh abrasives or household cleaners as they may damage the finish.
- Check all the fittings periodically and re-tighten as necessary. Do not use the product if any of the parts is damaged or broken.

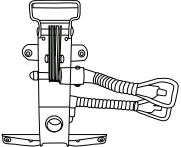
Note: Original Box has to be kept for the return until you decide to keep the item.

PARTS LIST

No.	Description	QTY	No.	Description	QTY
A		1	G		1
B		1	H		2
C		1	I		1
D		5	J		1
E		5	K		1
F		1			

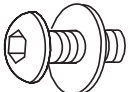
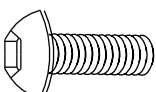
HARDWARE LIST

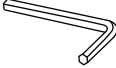
No.	Description	QTY	No.	Description	QTY
101	 M6*12	10	104	 M8*20	4
102	 M6*25	12	105	 M6*30	2
103	 M6*20	4	106	 M6	1

CAUTION: Please confirm the parts list before installtion

1 Insert Base Legs [**D**] one by one to the Base Center [**G**]. Next, screw 10 Screws [**101**] into the holes with the Allen Wrench [**106**] to attach the base and the legs.

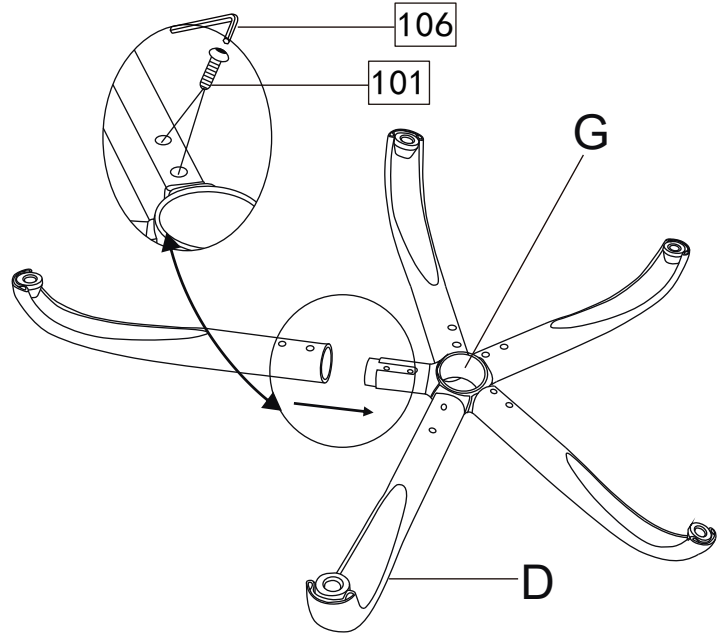
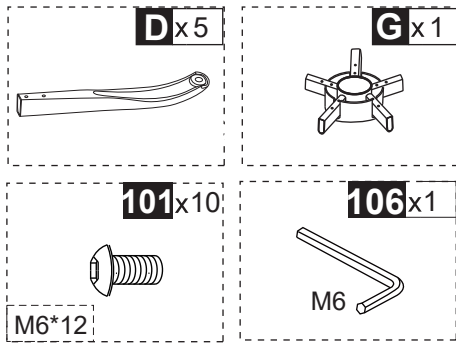

2 Insert the Casters [**E**] into the 5 star base. This may take significant force. Gentle squeeze the base cover and place around the center of the 5 star base. Insert the Gas Lift Cylinder [**C**] into the center of the base.

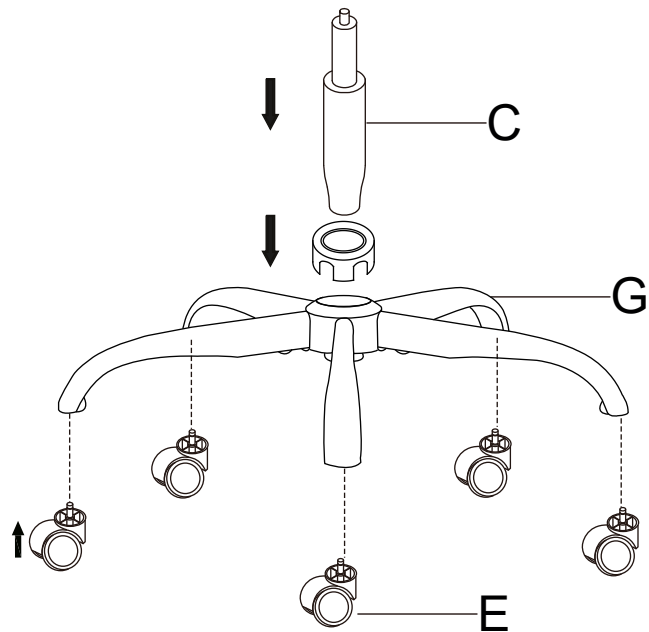
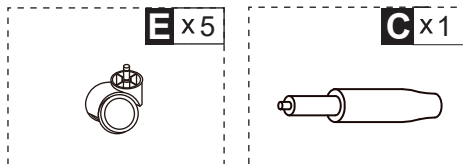

3 Assemble the Armrest Frame [**HX2**] with the Seat [**B**] via 8 Screws [**102**].
Turn the screws and finish with Allen Wrench [**106**].

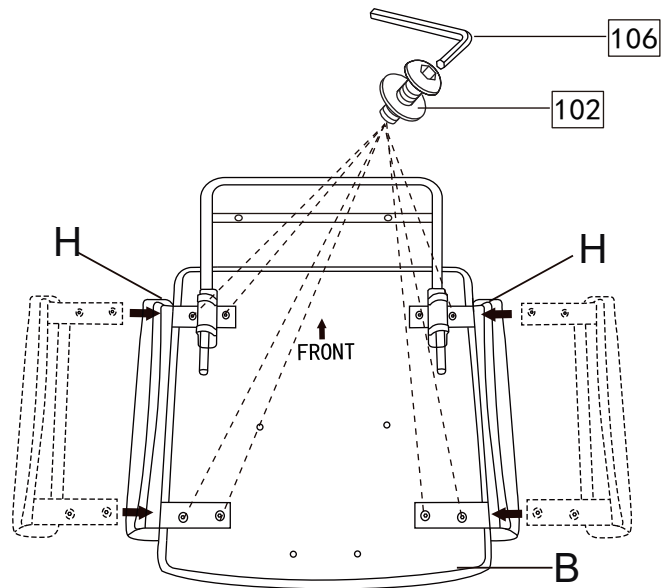
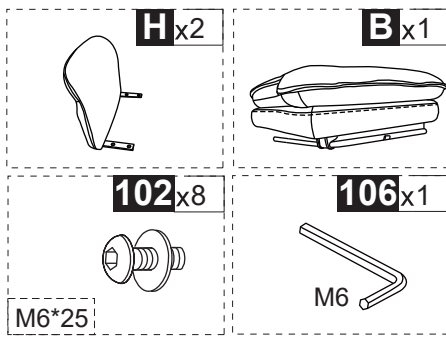

4 Assemble the Tilt Mechanism [**F**] with the Seat [**B**] via 4 Screws [**103**].
Turn the screws and finish with Allen Wrench [**106**].

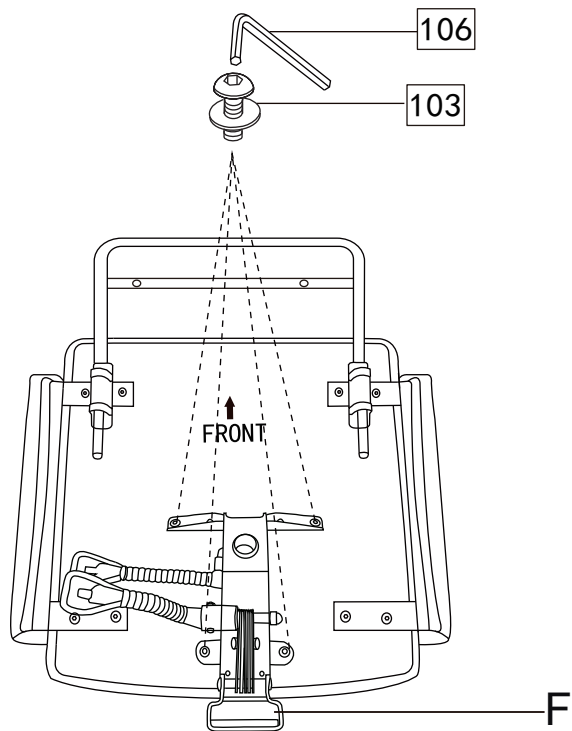
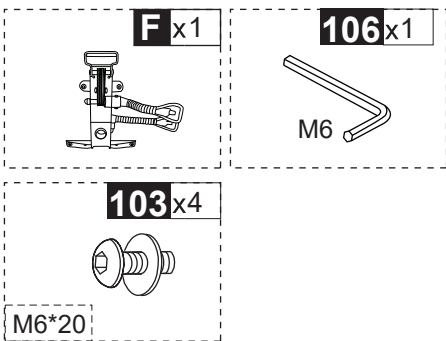

5 Attach the assembled seat to the assembled base by aligning the hole in the mechanism to the top of the gas cylinder.

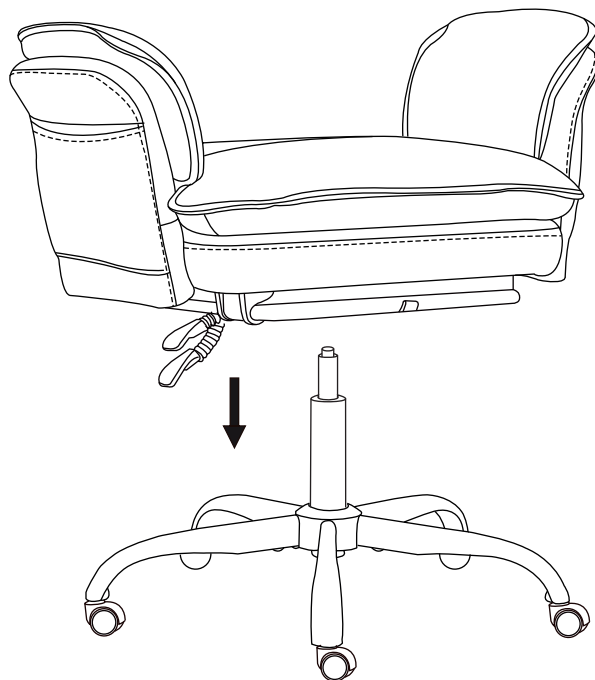

6 Attach the Iron Sheet [I] to the Back [A] via 4 Screws [102].
Turn the screws and finish with Allen Wrench [106].

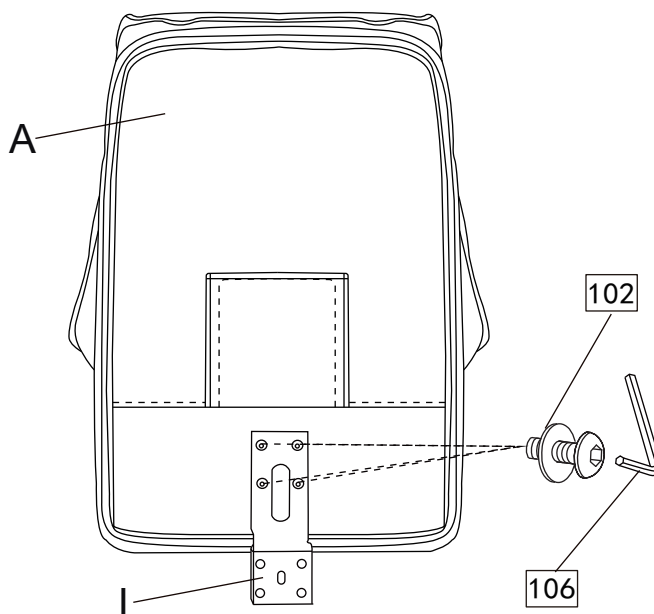
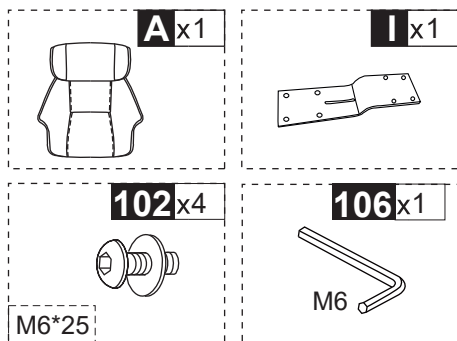

7 Attach the Iron Sheet [I] to the Seat [B] via 4 Screws [104].
Turn the screws and finish with Allen Wrench [106].

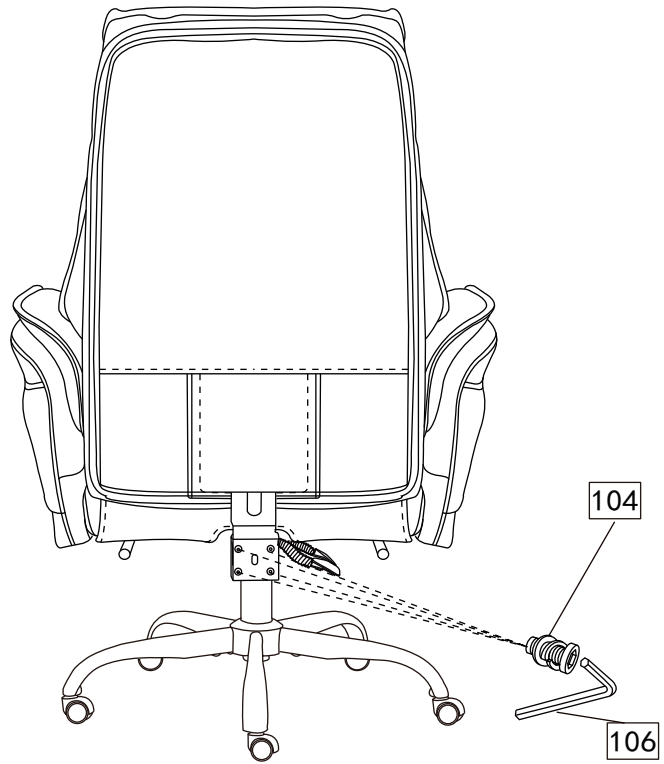
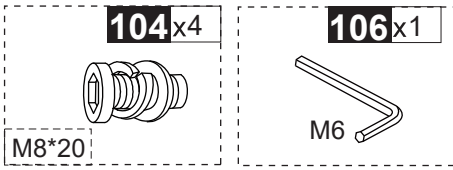

8 Connect the foot bracket pad [K] to the footrest via the 2 screws [105].
Turn the screws and finish with Allen Wrench [106].

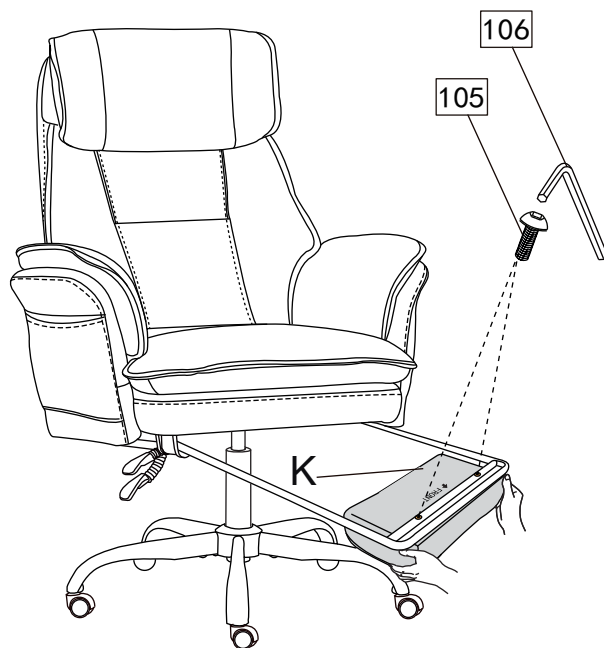
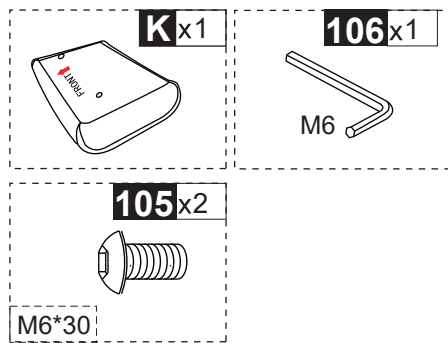

9

You can place a pillow here for lumbar support.

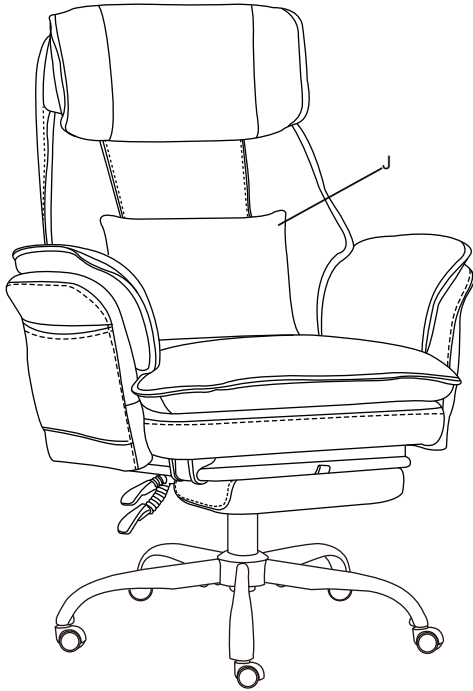

You can also tie the pillow here for neck support.



10

Enjoy Your New Chair !



THANK YOU

