

## PARTS LIST

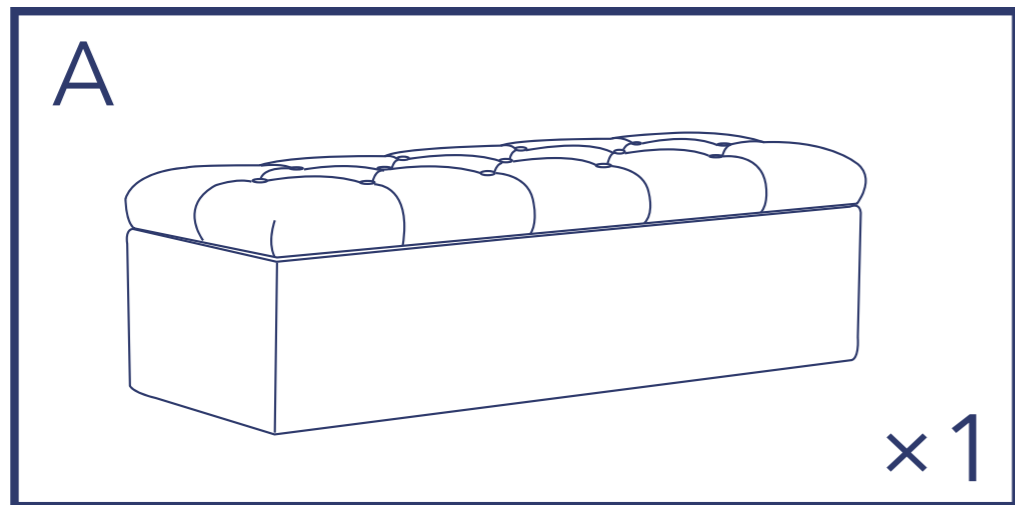

## HARDWARE LIST

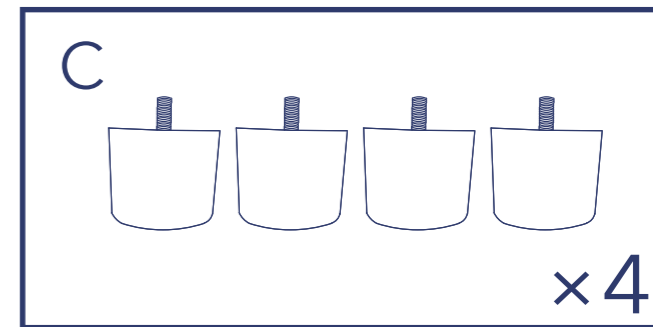
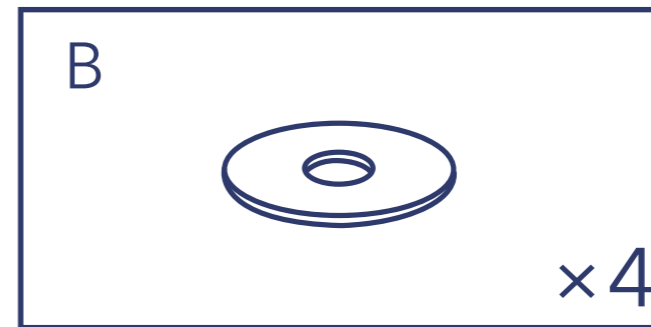

## STEP1

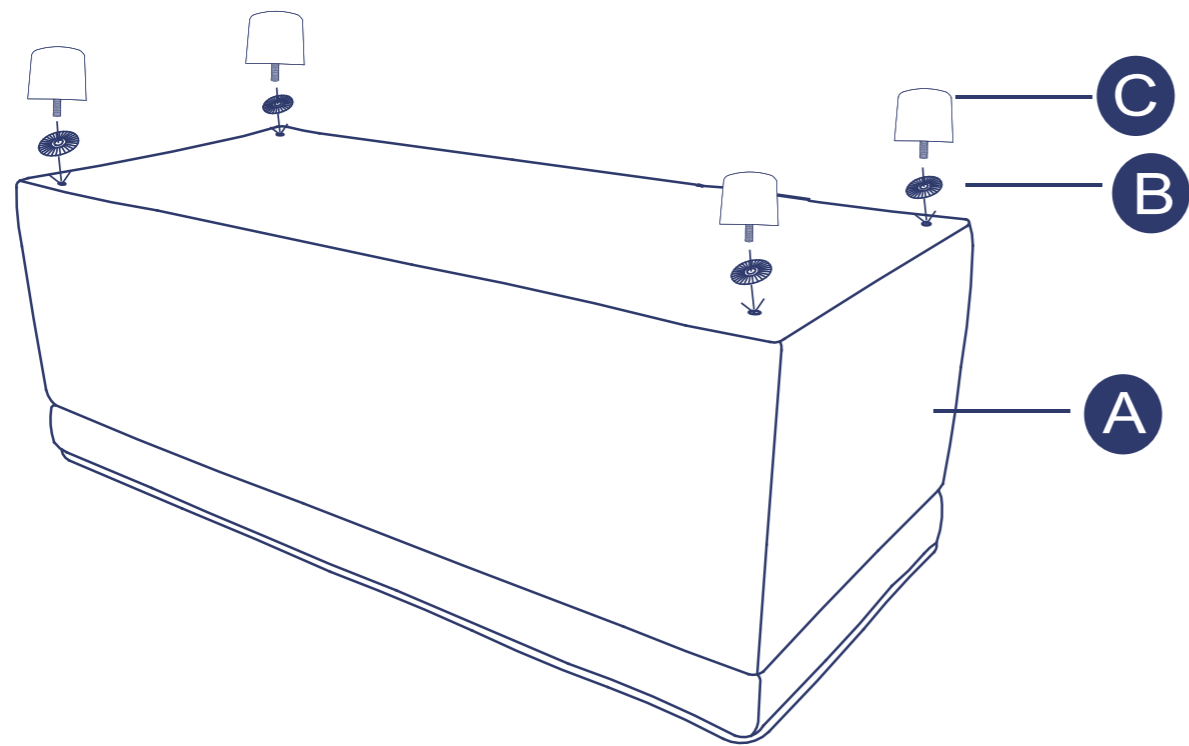

## STEP2

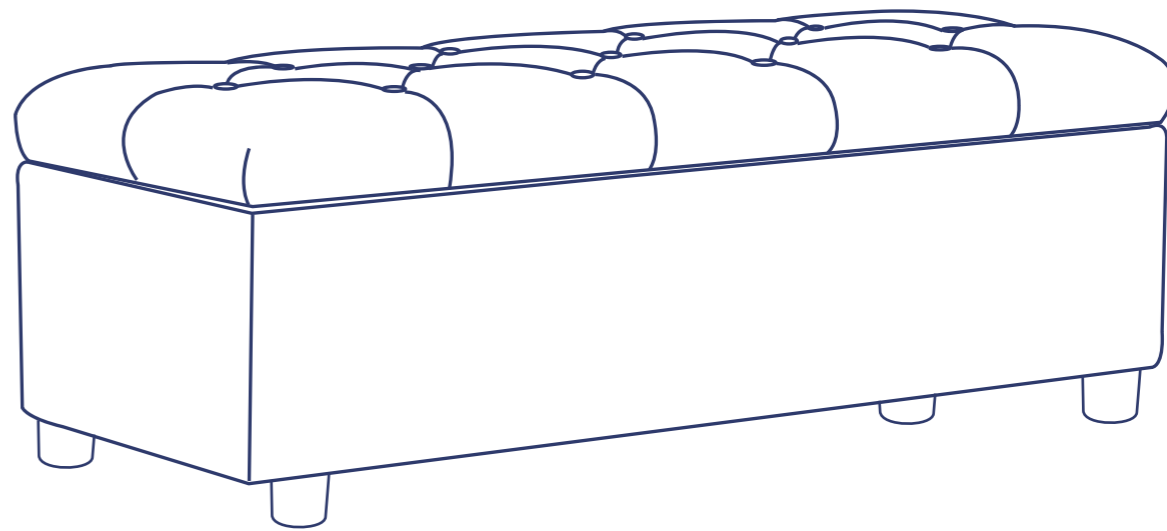

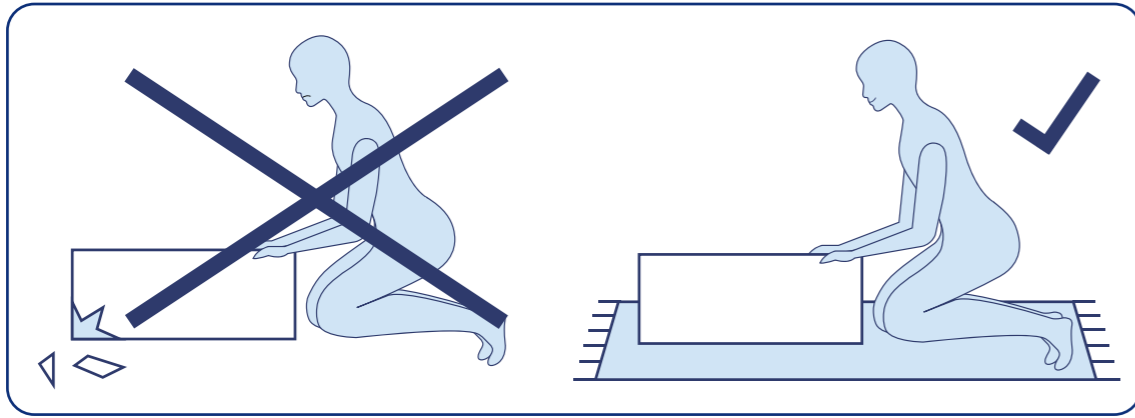

Dear Customer,

Thank you very much for purchasing our item. Please carefully review the assembly and care instructions before proceeding with assembly. We are continually striving to enhance the quality of our products and their packaging. If you find any reason for a claim, we kindly request your assistance.

Please get in touch with the store where you made your purchase and specify the reason for your claim.

In case the product is damaged, kindly provide the following information:

- A photo illustrating the reason for your claim or the damage.
- A photo of the carton displaying our Order Number for classification purposes.
- If damaged, a photo of the packaging (both inside and outside).

We greatly appreciate your support!