

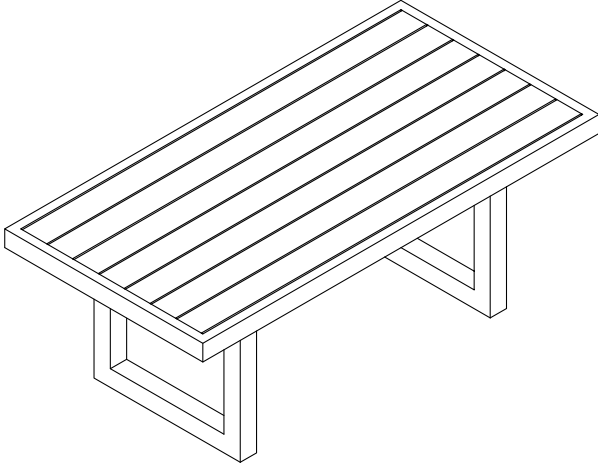



Outdoor Wicker Coffee Table



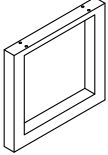

PART LIST

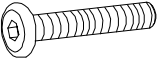
<p>A</p> 	<p>B</p> 
<p>Top Panel 1 PC</p>	<p>Leg 2 PCS</p>

HARDWARE LIST

<p>#1</p>  <p>M6*35mm</p>	<p>#2</p>  <p>M6mm</p>	<p>#3</p>  <p>M6mm</p>
<p>Bolt 8 PCS</p>	<p>Washer 8 PCS</p>	<p>Allen Key 1 PC</p>

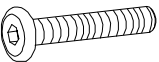
EXTRA HARDWARE LIST

<p>#1</p>  <p>M6*40mm</p>	<p>#2</p>  <p>M6mm</p>
<p>Bolt 1 PC</p>	<p>Washer 1 PC</p>

Step 1. Lay top panel (part A) down on a soft flat surface, such as carpet, as shown below. Attach legs (part B) to top panel (part A) using bolts (part #1), washers (part #2) and allen key (part #3).

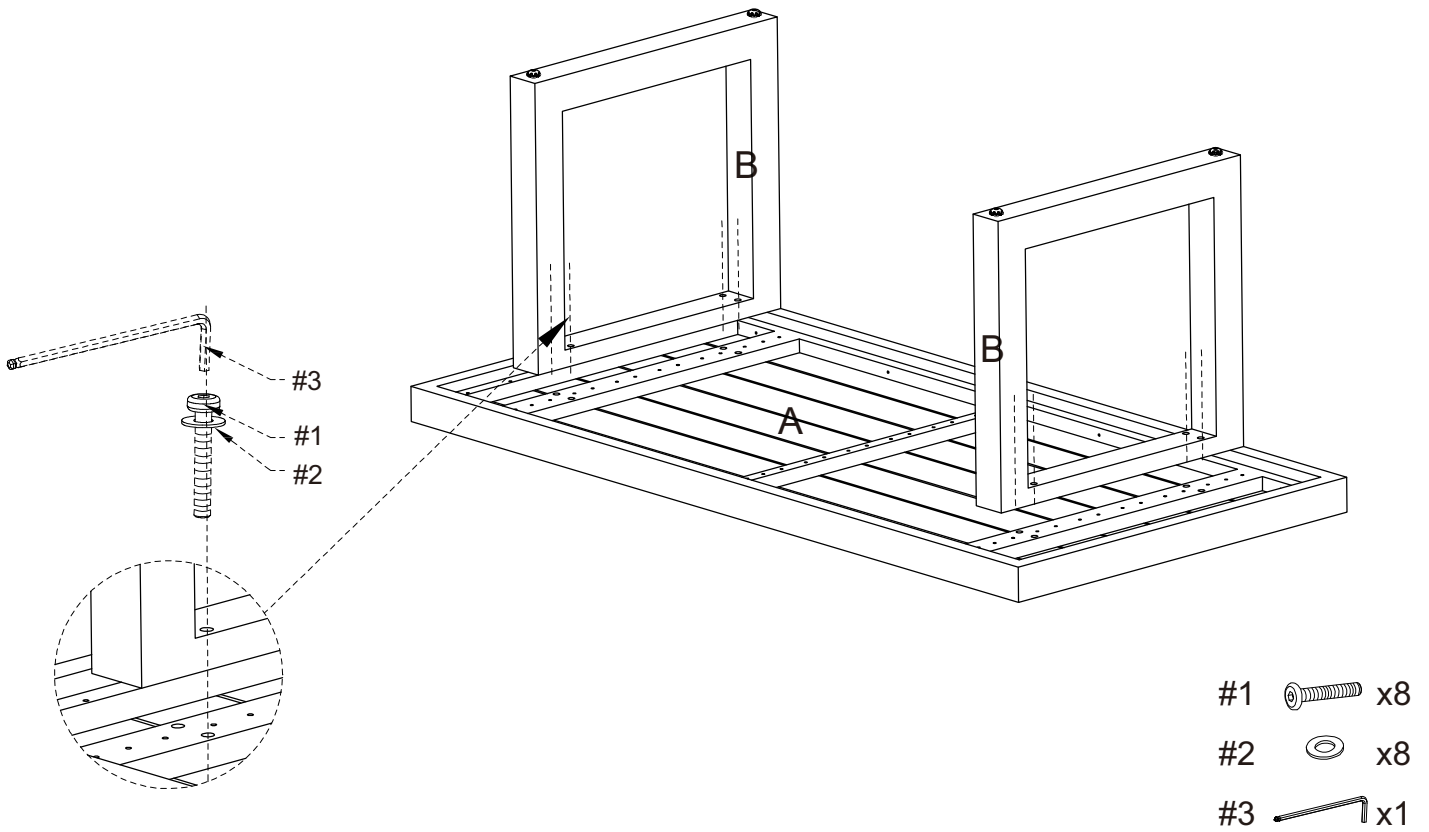

Step 2. Carefully turn table upright.

