

Suggestion:

For a simpler and quicker assembly process,
we recommend that two people work together.

Due to the product's structure, the estimated assembly time is 100 minutes.

IMPORTANT:

1. Please read the instructions carefully before assembling the product.
2. Before starting the assembly process, check the package carefully to make sure all necessary boards and parts are included.
3. If there are any defective or missing parts after unpacking, please stop assembly and immediately contact us.
4. Before assembly, put all parts and boards in an open area. Ensure that you have the correct parts before screwing them in place.

Warning:





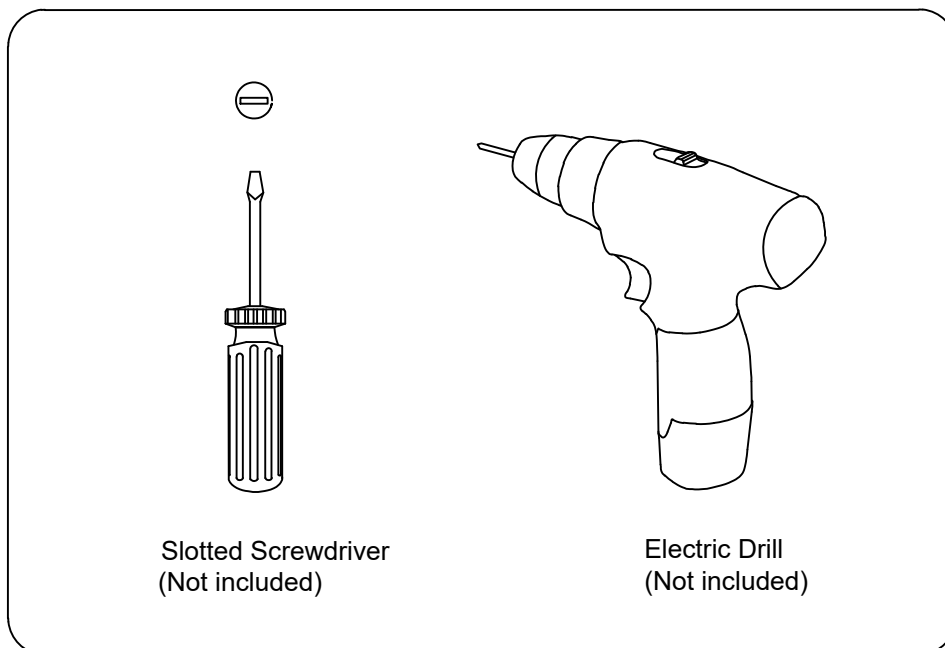

1. During assembly, keep all small objects out of the reach of children, as they may be fatalif swallowed or inhaled
2. Never allow children to climb or play around the product to protect children from injury caused by the tilting of the product.
3. To avoid the potential dangers of suffocation, please keep all parts and packaging away from children.

Self equipped tools



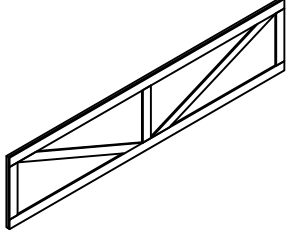
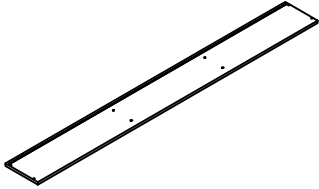
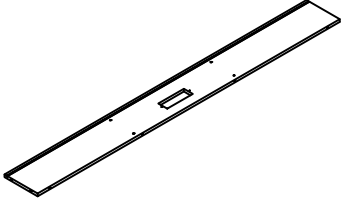
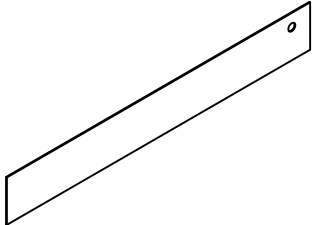

Parts Identification 1/3

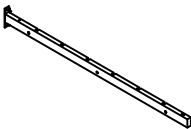
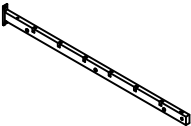
Not actual size

| | | |
|---|---|---|
| <p>①</p>  <p>Q'ty: 1</p> | <p>②</p>  <p>Q'ty: 1</p> | <p>③</p>  <p>Q'ty: 1</p> |
| <p>④</p>  <p>Q'ty: 1</p> | <p>⑤</p>  <p>Q'ty: 1</p> | <p>⑥</p>  <p>Q'ty: 1</p> |
| <p>⑦</p>  <p>Q'ty: 1</p> | <p>⑧</p>  <p>Q'ty: 1</p> | <p>⑨</p>  <p>Q'ty: 1</p> |
| <p>⑩</p>  <p>Q'ty: 1</p> | <p>⑪</p>  <p>Q'ty: 1</p> | <p>⑫</p>  <p>Q'ty: 1</p> |

Parts Identification 2/3

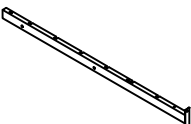
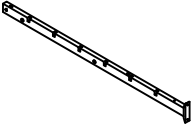
Not actual size

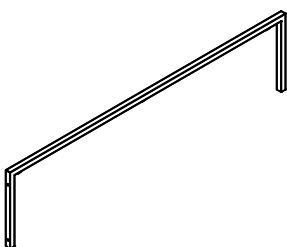
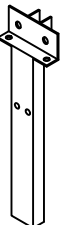
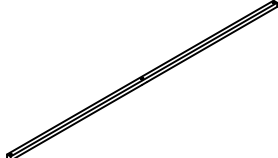
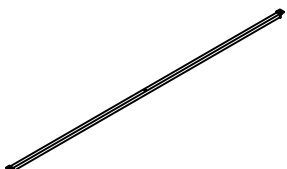
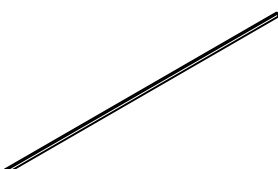
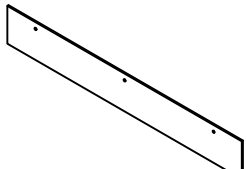
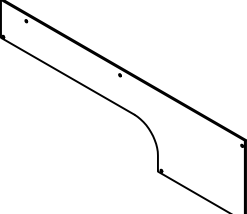
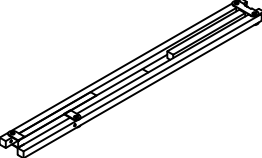
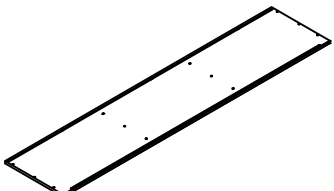
| | | |
|--|---|--|
| <p>13</p>  <p>Q'ty: 1</p> | <p>14</p>  <p>Q'ty: 1</p> | <p>15</p>  <p>Q'ty: 2</p> |
| <p>16</p>  <p>Q'ty: 1</p> | <p>17</p>  <p>Q'ty: 2</p> | <p>18</p>  <p>Q'ty: 1</p> |
| <p>19</p>  <p>Q'ty: 2</p> | <p>20</p>  <p>Q'ty: 12</p> | <p>21</p>  <p>Q'ty: 2</p> |
| <p>22</p>  <p>Q'ty: 2</p> | <p>23</p>  <p>Q'ty: 1</p> | <p>24</p>  <p>Q'ty: 1</p> |

Parts Identification 3/3

Not actual size

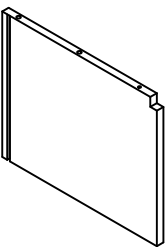
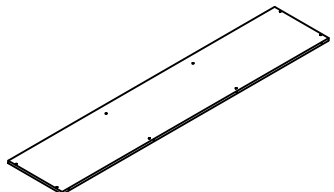
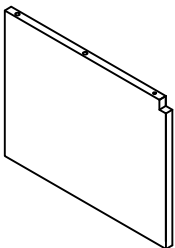
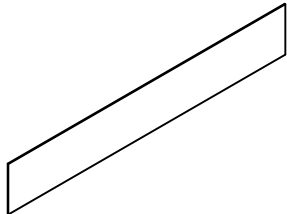
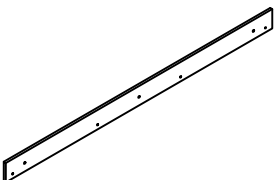
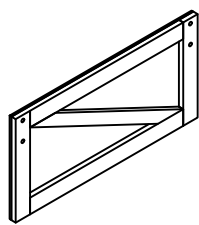
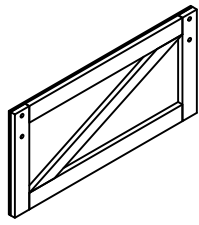
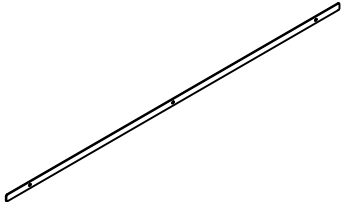
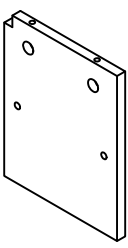
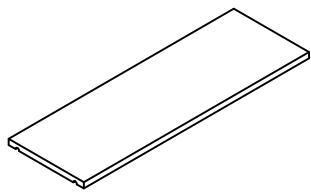
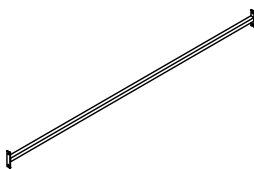
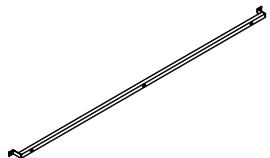
| | | |
|--|--|--|
| <p>(25)</p>  <p>Q'ty: 2</p> | <p>(26)</p>  <p>Q'ty: 1</p> | <p>(27)</p>  <p>Q'ty: 2</p> |
| <p>(28)</p>  <p>Q'ty: 1</p> | <p>(29)</p>  <p>Q'ty: 1</p> | <p>(30)</p>  <p>Q'ty: 1</p> |
| <p>(31)</p>  <p>Q'ty: 1</p> | <p>(32)</p>  <p>Q'ty: 1</p> | <p>(33)</p>  <p>Q'ty: 2</p> |
| <p>(34)</p>  <p>Q'ty: 1</p> | <p>(35)</p>  <p>Q'ty: 1</p> | <p>(36)</p>  <p>Q'ty: 1</p> |

Hardware List

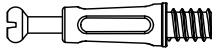

(A) x 22+2



(B) x 22+2

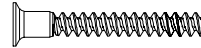

Ø5 x 38mm

(C) x 30+3

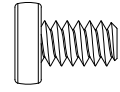

Ø1/4" x 11mm

(D) x 27+2

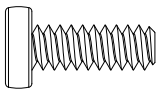

Ø1/4" x 16mm

(E) x 12+1

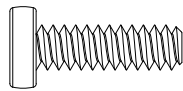

Ø1/4" x 25mm

(F) x 21+1

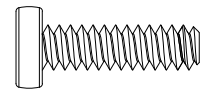

Ø1/4" x 28mm

(G) x 3+1

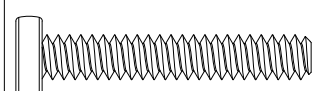

Ø1/4" x 60mm

(H) x 5+1

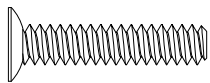

Ø1/4" x 28mm

(I) x 3+1

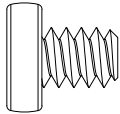

M8 x 28mm

(J) x 2+1

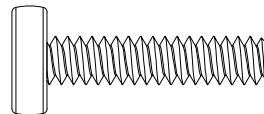

M8 x 50mm

(K) x 4+1

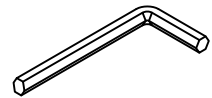

M4

(L) x 1

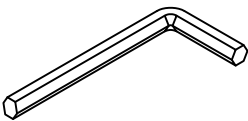

M5

(M) x 1



M3

(N) x 1

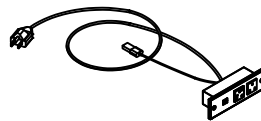

(O) x 1

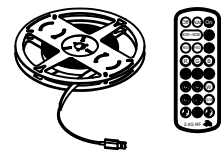

(P) x 1

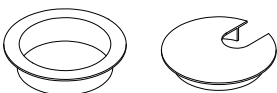

(Q) x 1

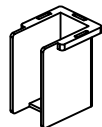

(R) x 24+2



(S) x 4

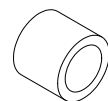

(T) x 3

Hardware List

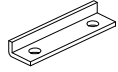

U

x 2



V

x 4

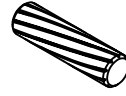

Ø6 x 30mm

W

x 8+1

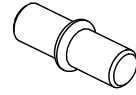

X

x 4+1

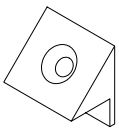

Y

x 4



Ø3 x 15mm

Z

x 4



Ø4 x 12mm

AA

x 6+1



BB

x 1

★ In many cases, we include additional hardware. So after following the assembly instructions, don't worry if there are still extra pieces left over-they're included as a "just in case" for your convenience.

★ NOTE: When assembling, please do not tighten the screws one by one completely first, until making sure that all the corresponding screws are placed in the right positions.

Parts Identification

Not actual size

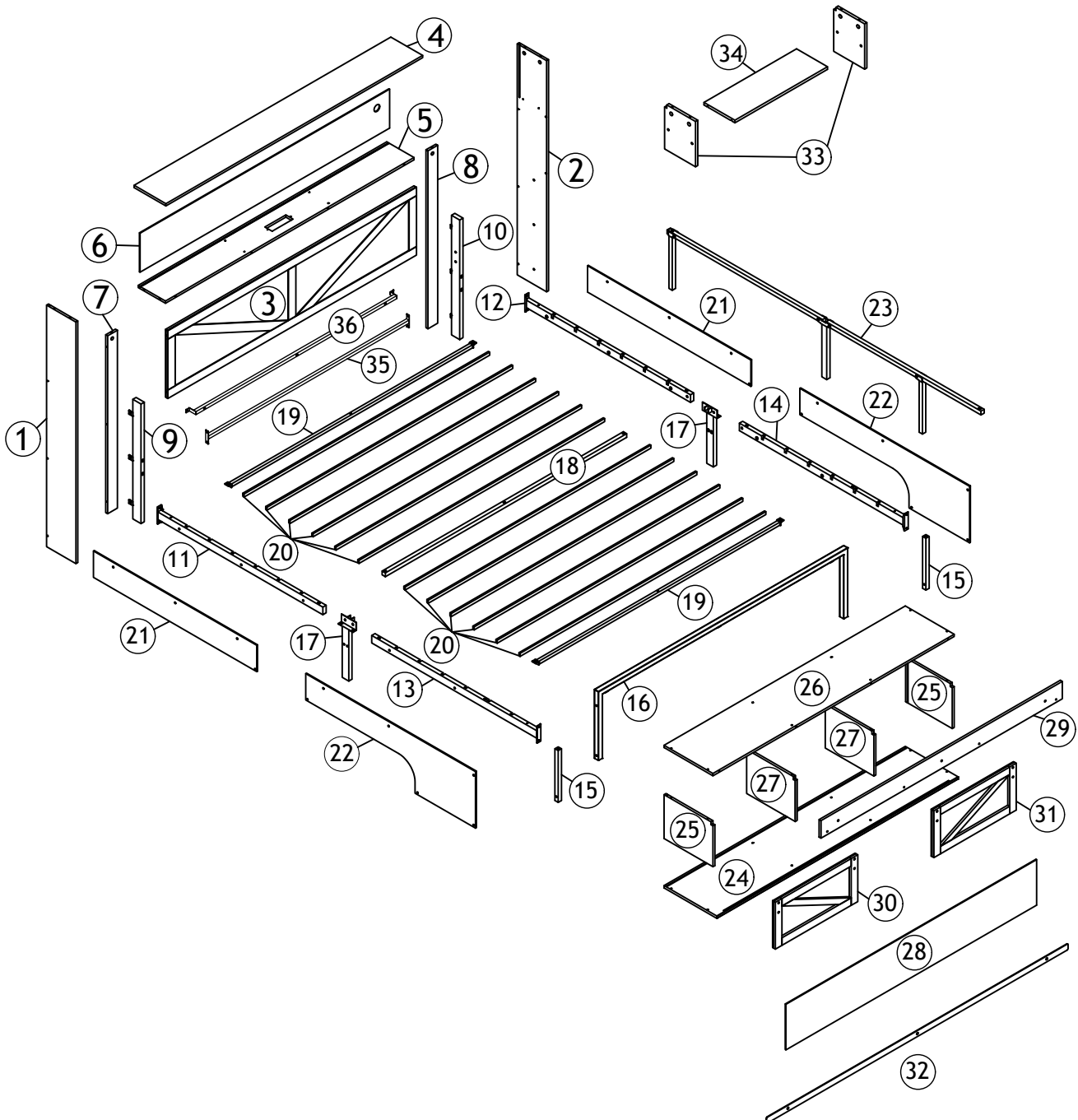









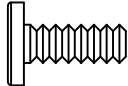

ATTENTION

When you begin each step, please check carefully whether you have taken the correct parts, so as not to use the wrong parts and cause the wrong assembly.

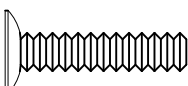
We recommend that you do not rush to tighten the screws. It is best to tighten the screws to two-thirds first, after all the steps are finished and the position is well adjusted, then tighten.

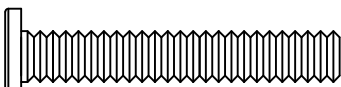
Screw Fitting 1:1 Diagram

| | | |
|-----------|---|--------------|
| C |  | Ø5 x 38mm |
| D |  | Ø1/4" x 11mm |
| E |  | Ø1/4" x 16mm |
| F |  | Ø1/4" x 25mm |
| G |  | Ø1/4" x 28mm |
| H |  | Ø1/4" x 60mm |
| I |  | Ø1/4" x 28mm |
| J |  | M8 x 28mm |
| K |  | M8 x 50mm |
| AA |  | φ4 x 12mm |
| Z |  | φ3 x 15mm |

STEP 1

 Please screws in this step need to be tightened

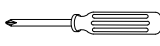
| |
|---|
|  |
| BB x 1 |

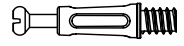
| |
|---|
|  |
| A x 4 |

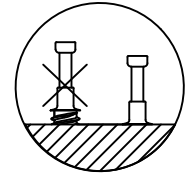
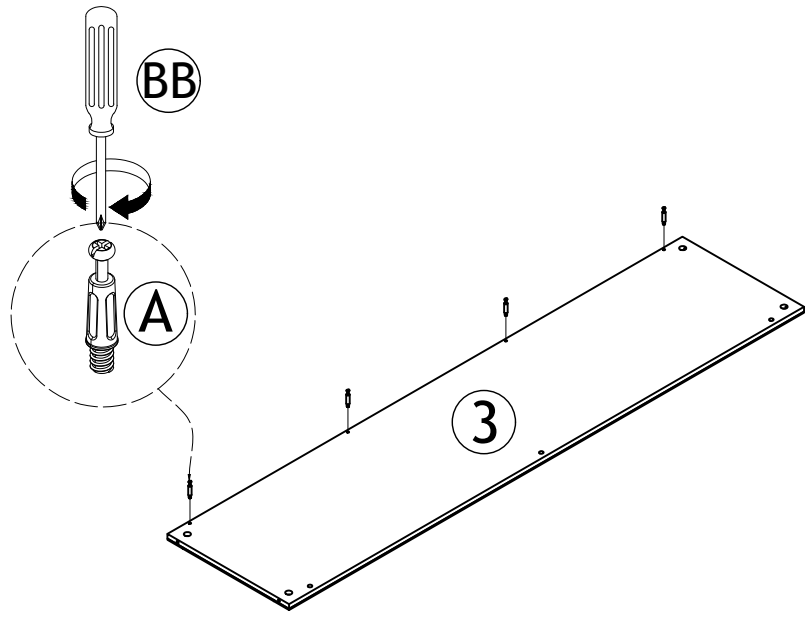

STEP 2

 Please screws in this step need to be tightened

| |
|--|
|  |
| $\text{Ø}5 \times 38\text{mm}$ |
| C x 4 |

| |
|---|
|  |
| M3 |
| N x 1 |

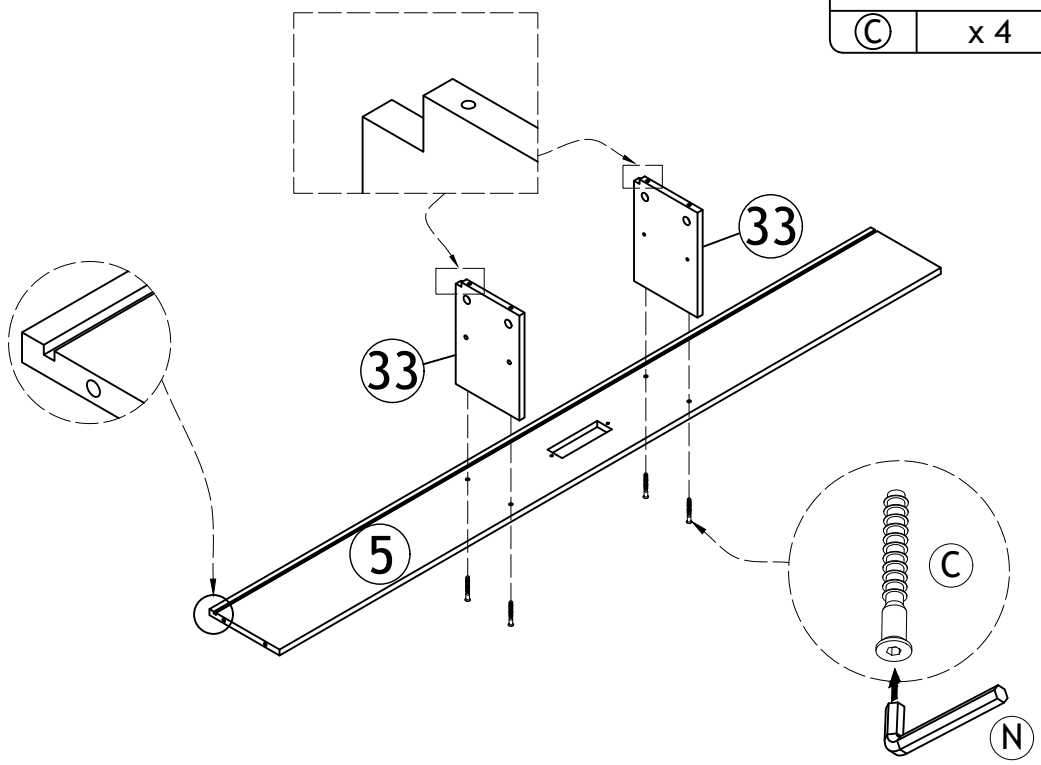

STEP 3

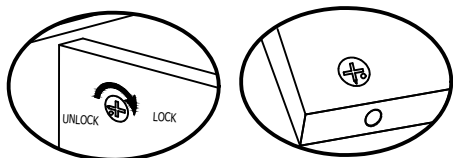

Proper orientation of CAM LOCK

! Please screws in this step need to be tightened

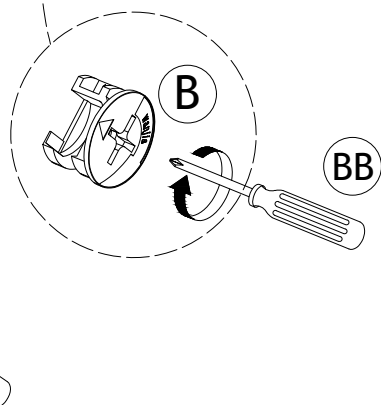
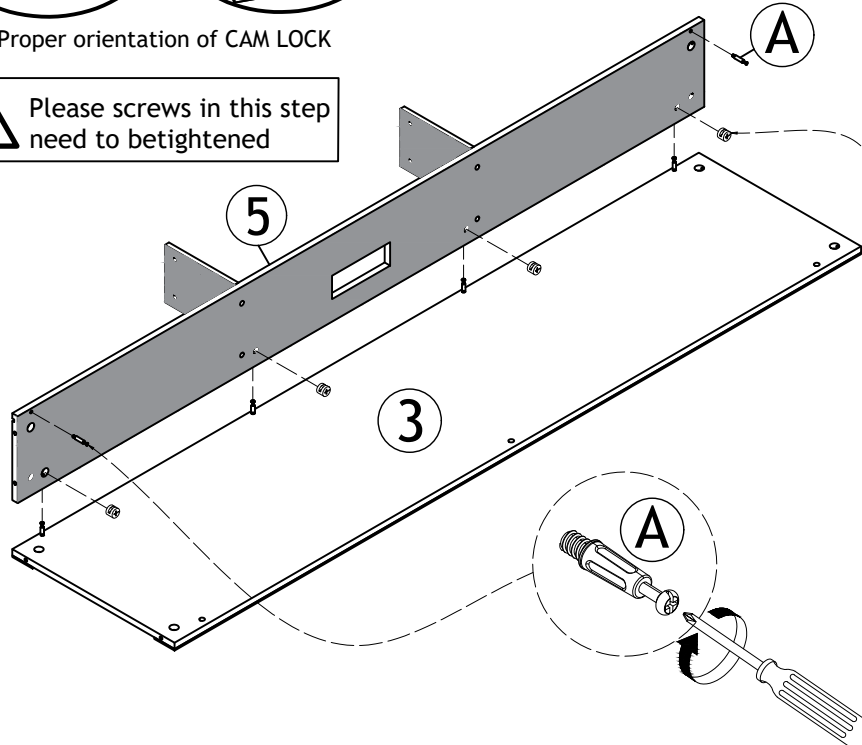
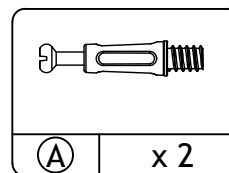
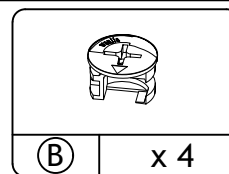
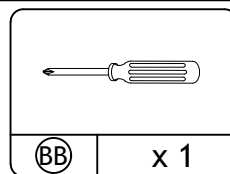

STEP 4

! Please screws in this step need to be tightened

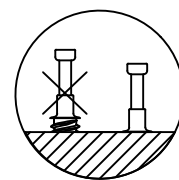
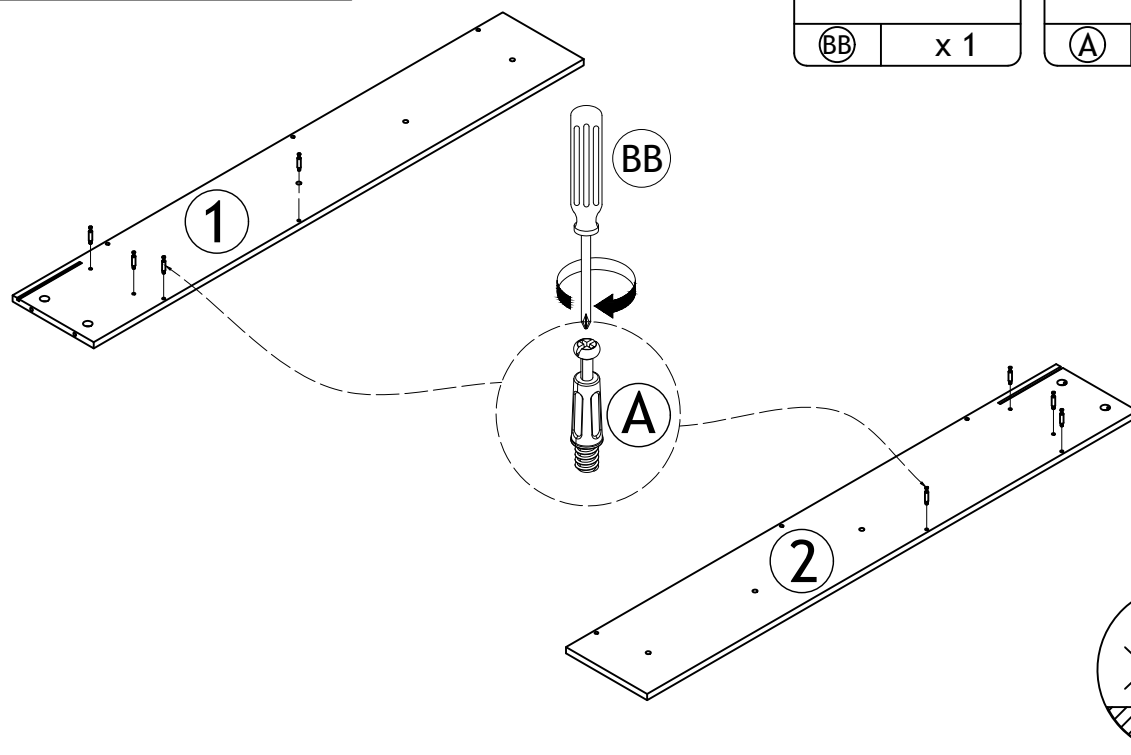
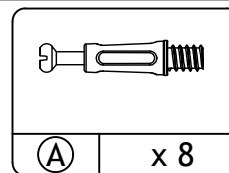
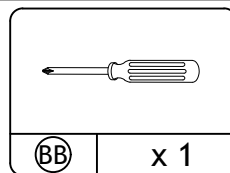

STEP 5

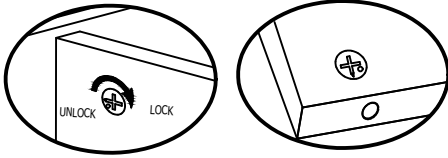

Proper orientation of CAM LOCK

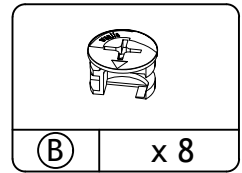
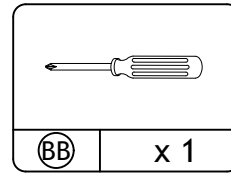

 Please screws in this step need to betightened

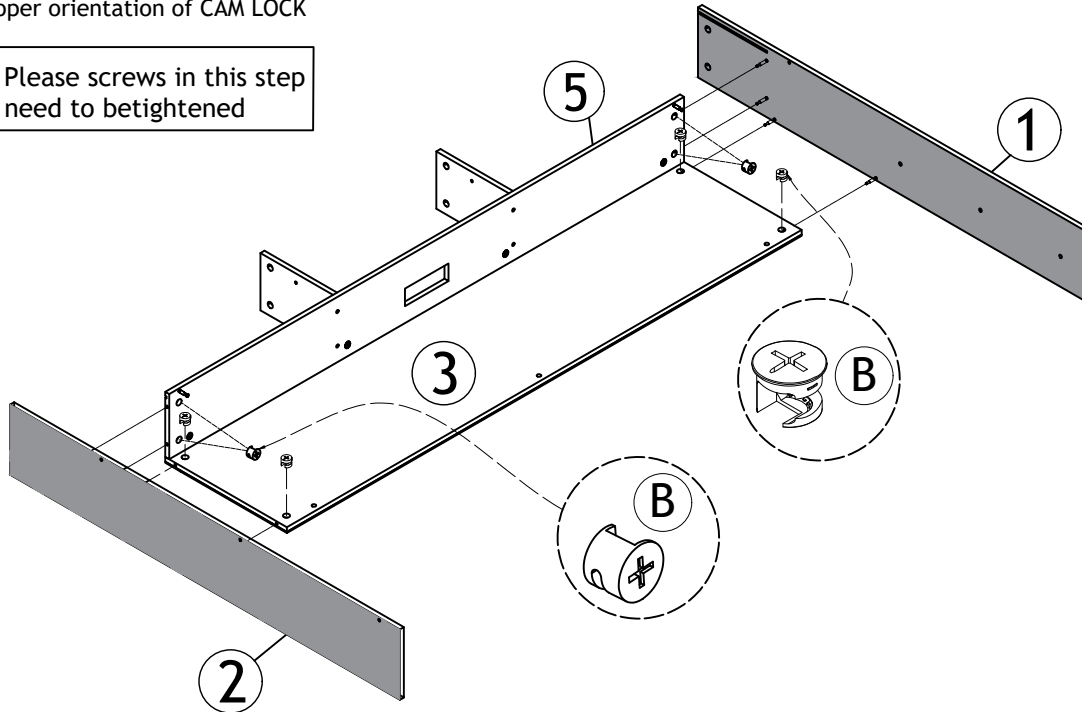

STEP 6

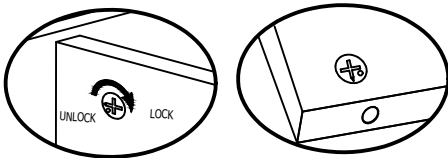

Proper orientation of CAM LOCK

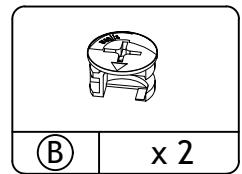
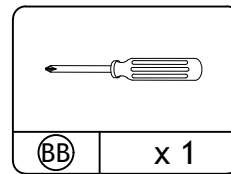

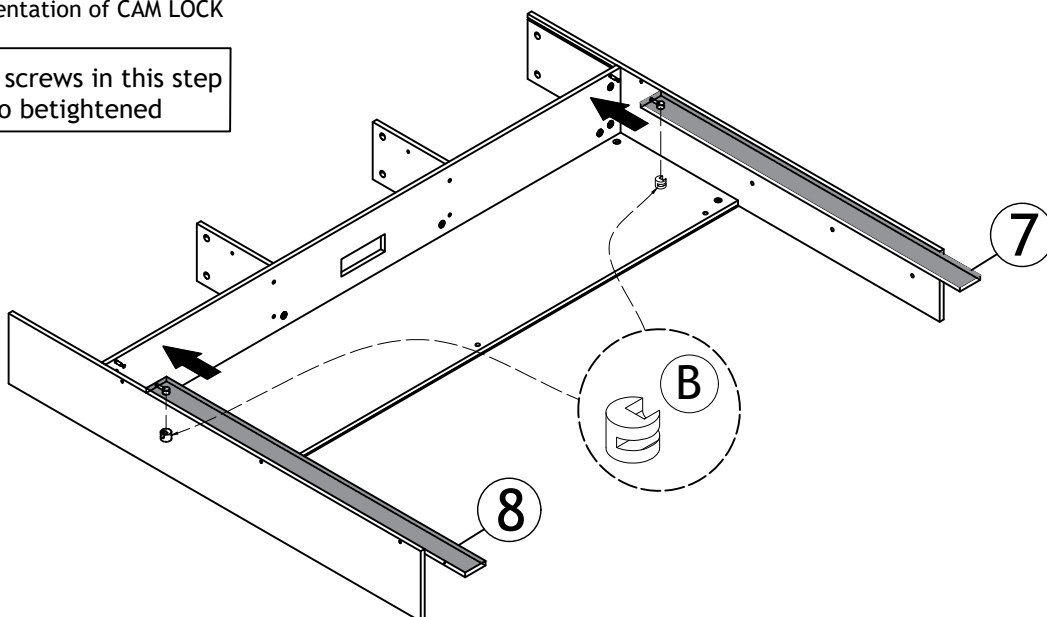

 Please screws in this step need to betightened

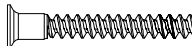

STEP 7

 Please screws in this step need to be tightened

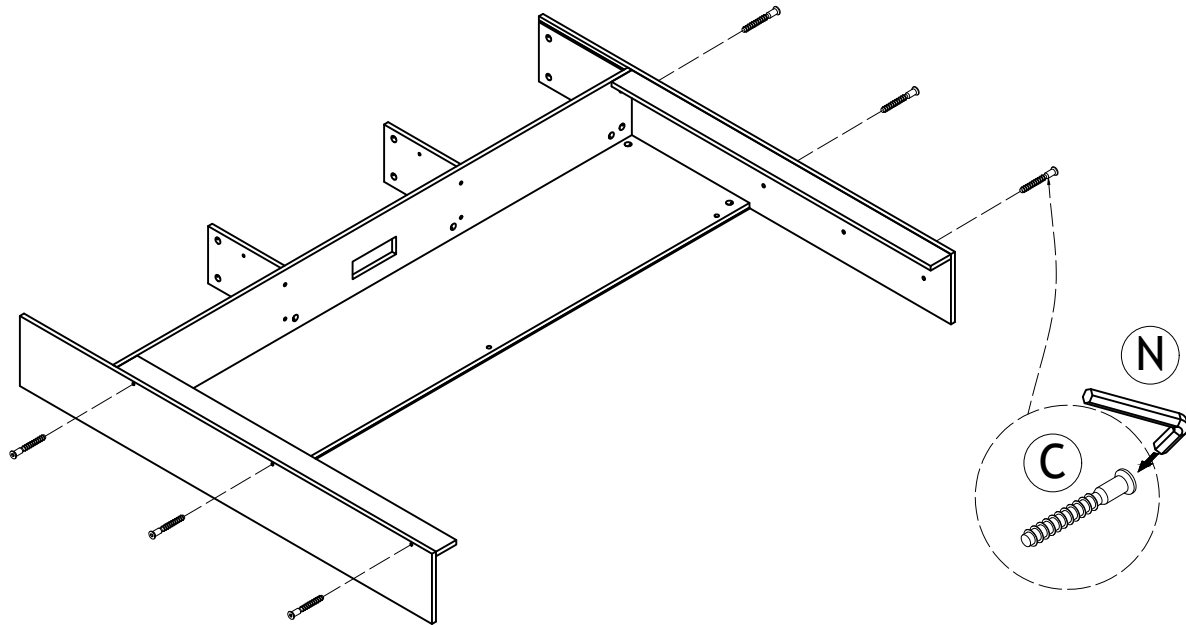

| | |
|--|-----------|
|  | Ø5 x 38mm |
| (C) | x 6 |

| | |
|---|-----|
|  | M3 |
| (N) | x 1 |



STEP 8

 Please tighten the bolts to 80% first, and tighten all bolts 100% after all parts are assembled.

| | |
|---|---|
|  |  |
|---|---|

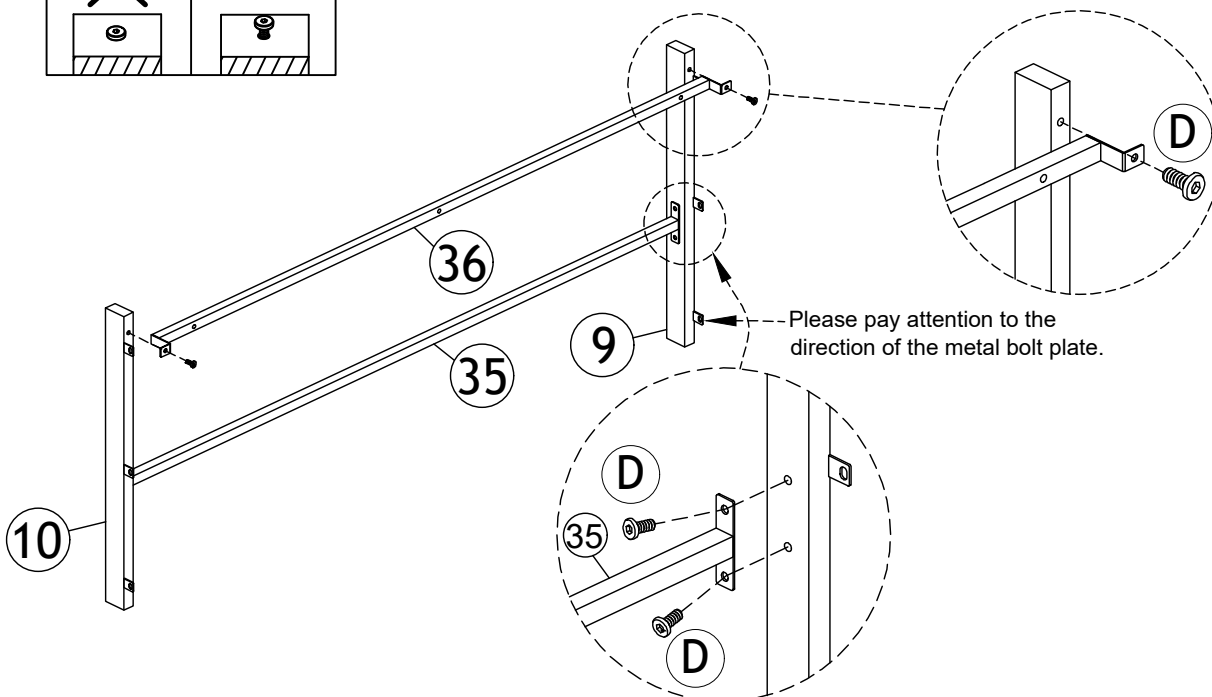

| | |
|---|--------------|
|  | Ø1/4" x 11mm |
| (D) | x 6 |

| | |
|---|-----|
|  | M4 |
| (L) | x 1 |

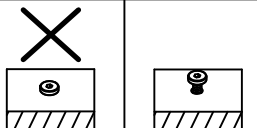

STEP 9

 Please tighten the bolts to 80% first, and tighten all bolts 100% after all parts are assembled.

Ø1/4" x 28mm
G x 3



Ø1/4" x 11mm
D x 6



M4
L x 1

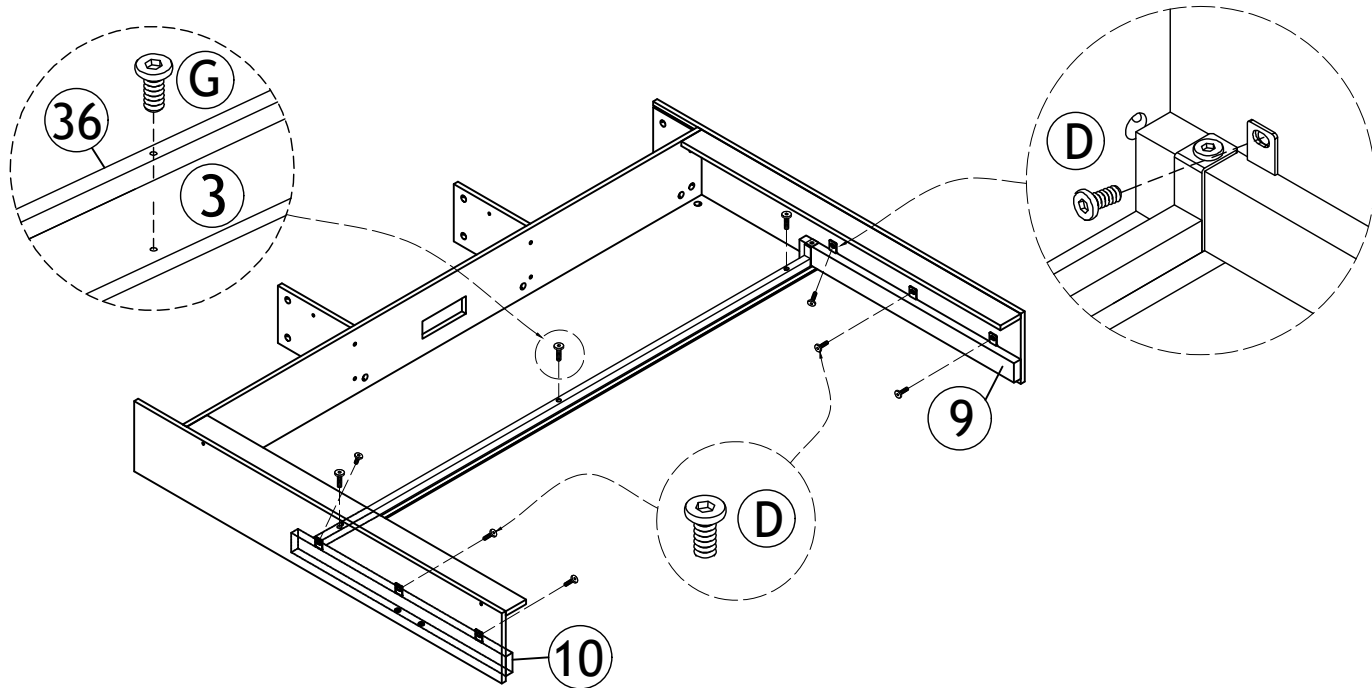

STEP 10

 Please screws in this step need to be tightened



O x 1

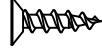

Ø4 x 12mm
AA x 2

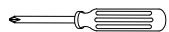

BB x 1

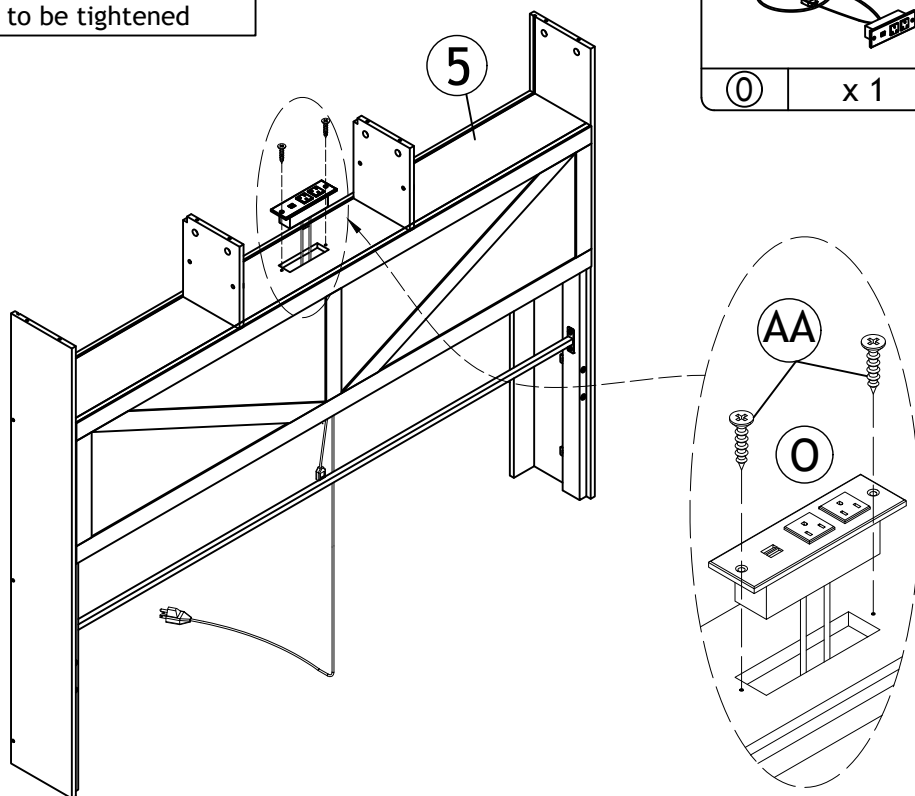

STEP 11

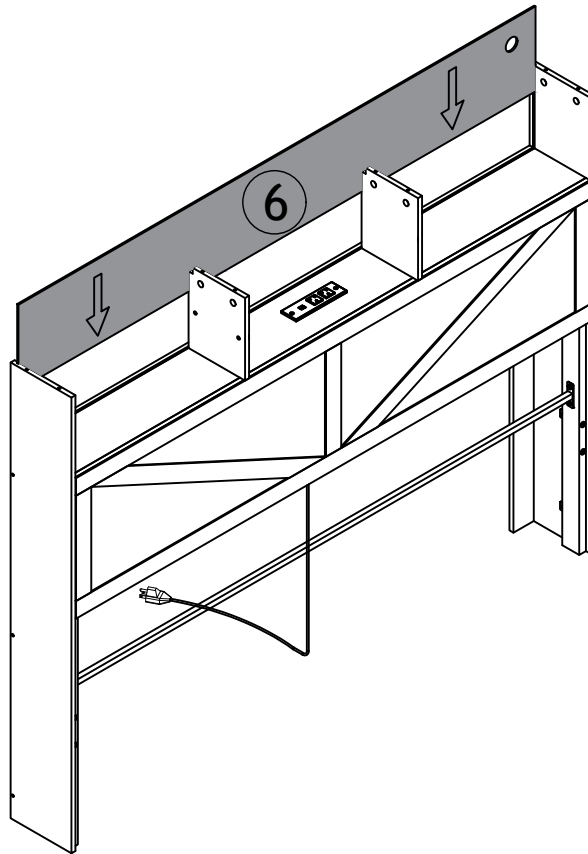

STEP 12

 Please screws in this step need to be tightened

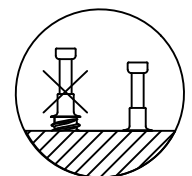
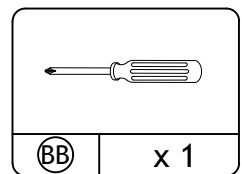
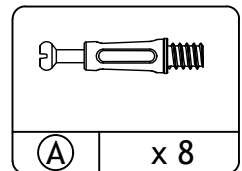
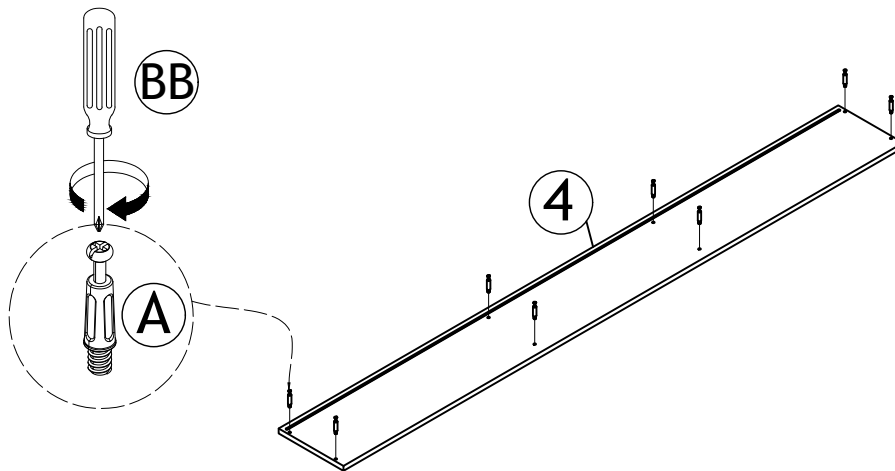

STEP 13

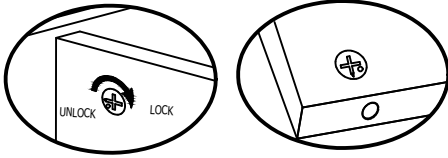

Proper orientation of CAM LOCK

 Please screws in this step need to be tightened

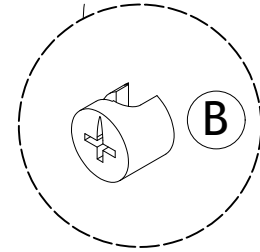
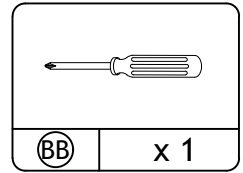
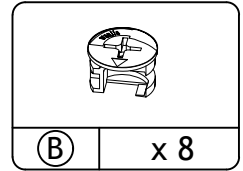
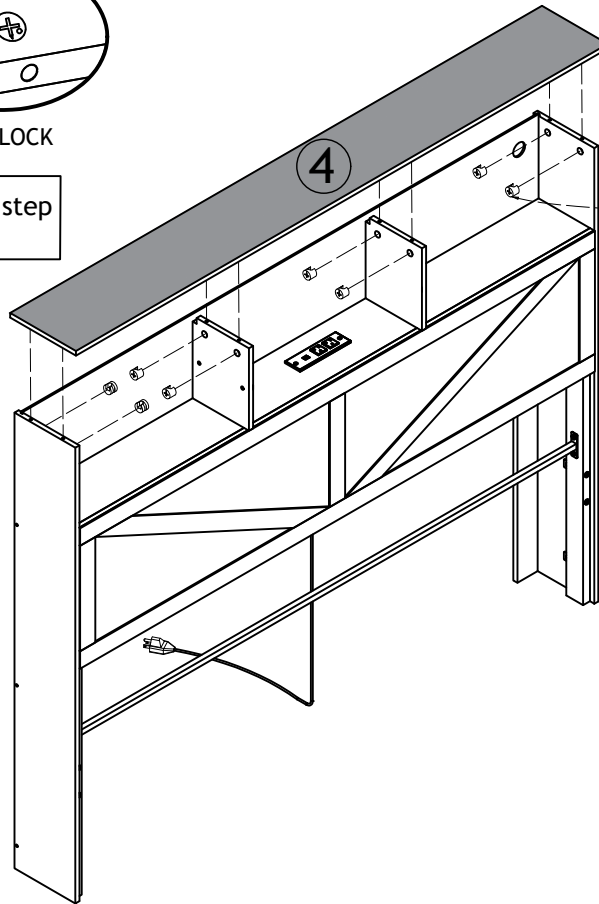

STEP 14

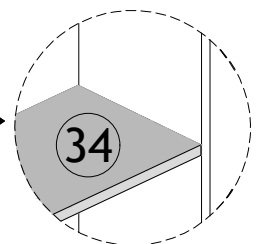
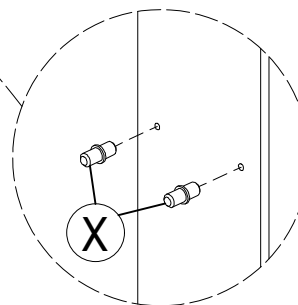
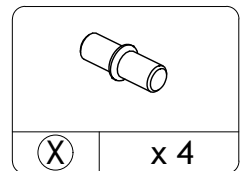
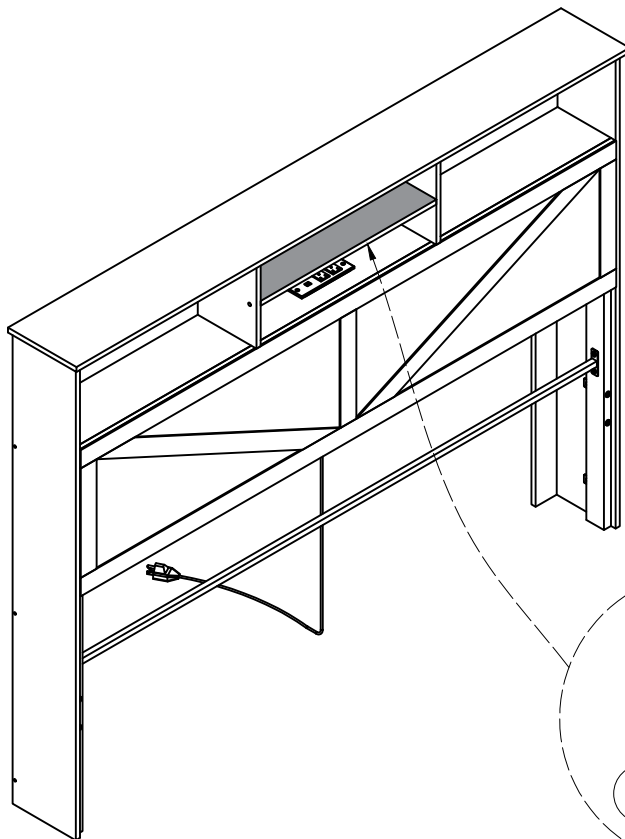

STEP 15

 Please screws in this step need to be tightened

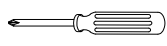
| |
|---|
|  |
| (BB) x 1 |

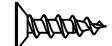

| |
|---|
|  |
| (Z) x 4 |

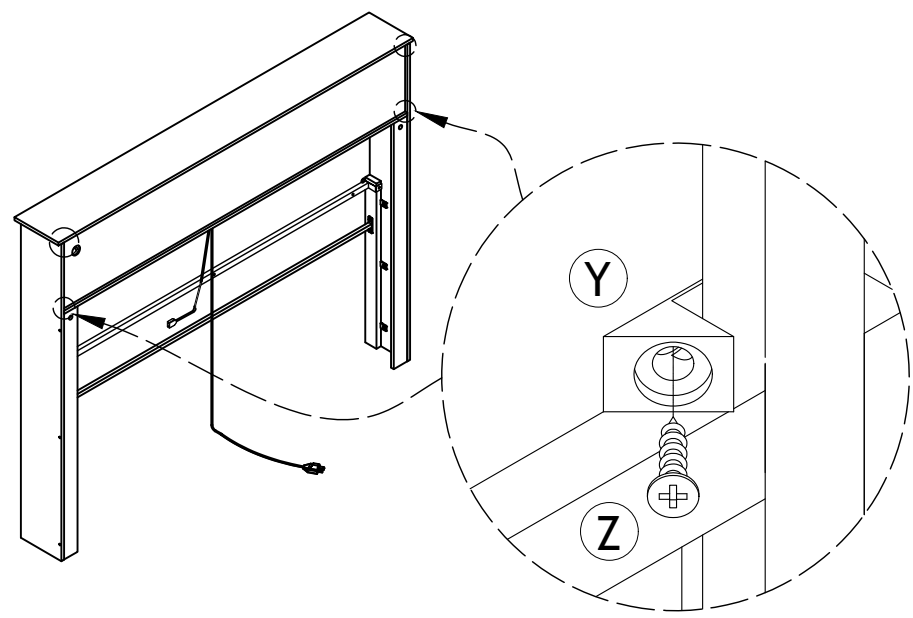
| |
|---|
|  |
| (Y) x 4 |



STEP 16

 Please tighten the bolts to 80% first, and tighten all bolts 100% after all parts are assembled.

| | |
|---|---|
|  |  |
|---|---|

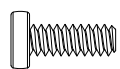
| |
|---|
|  |
| (E) x 4 |

| |
|---|
|  |
| (L) x 1 |

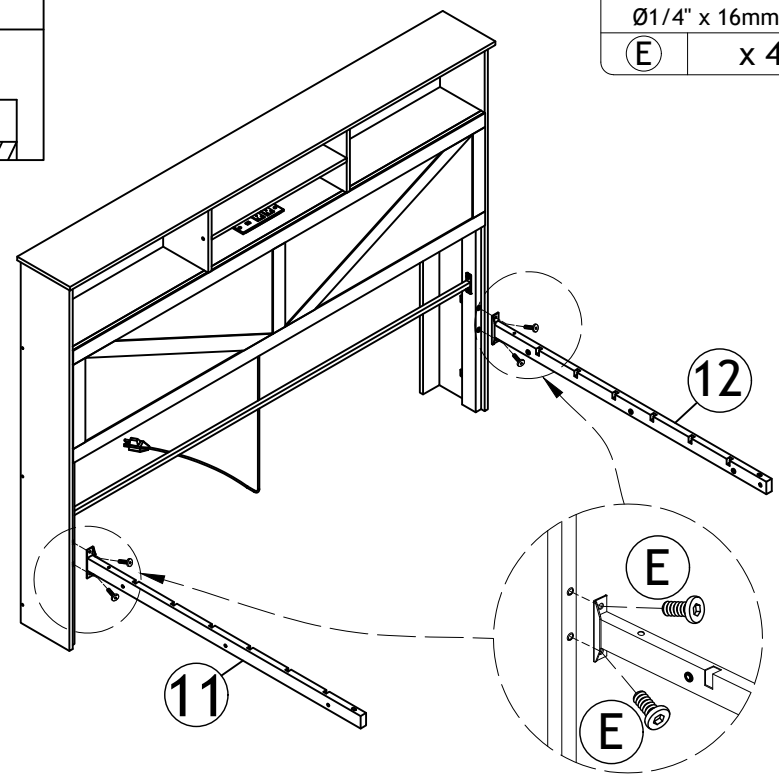

STEP 17

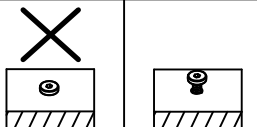
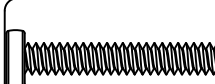

 Please tighten the bolts to 80% first, and tighten all bolts 100% after all parts are assembled.

$\text{Ø}1/4" \times 60\text{mm}$
 (H) x 2



M4
 (L) x 1

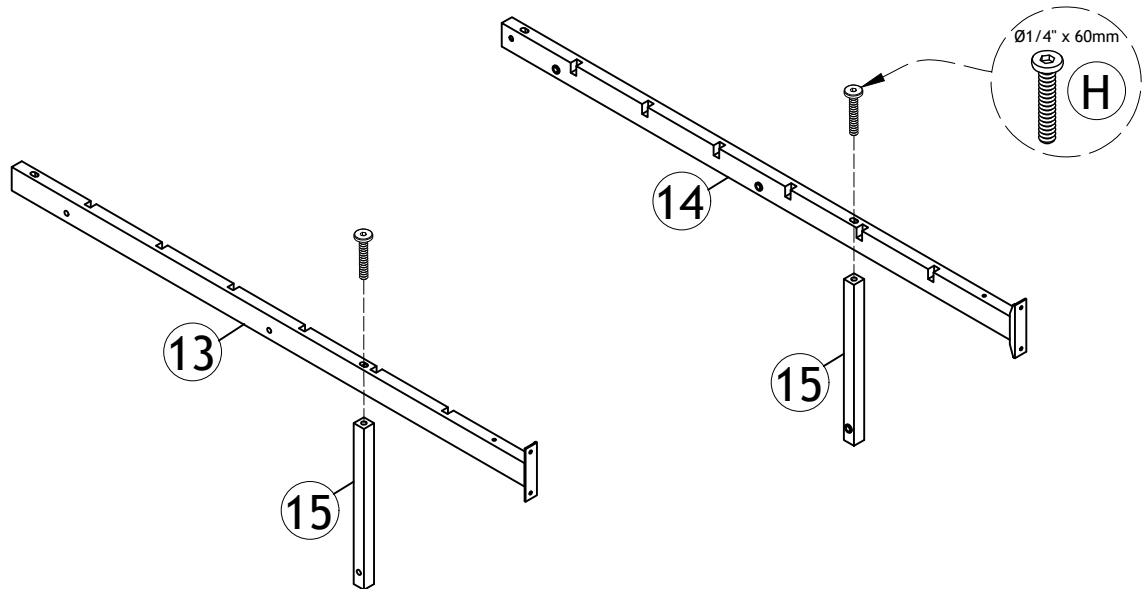

STEP 18

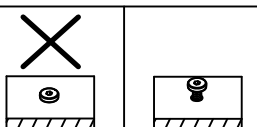
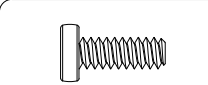

 Please tighten the bolts to 80% first, and tighten all bolts 100% after all parts are assembled.

$\text{Ø}1/4" \times 16\text{mm}$
 (E) x 4

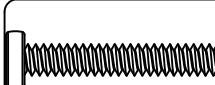

M8 x 50mm
 (K) x 4



M4
 (L) x 1



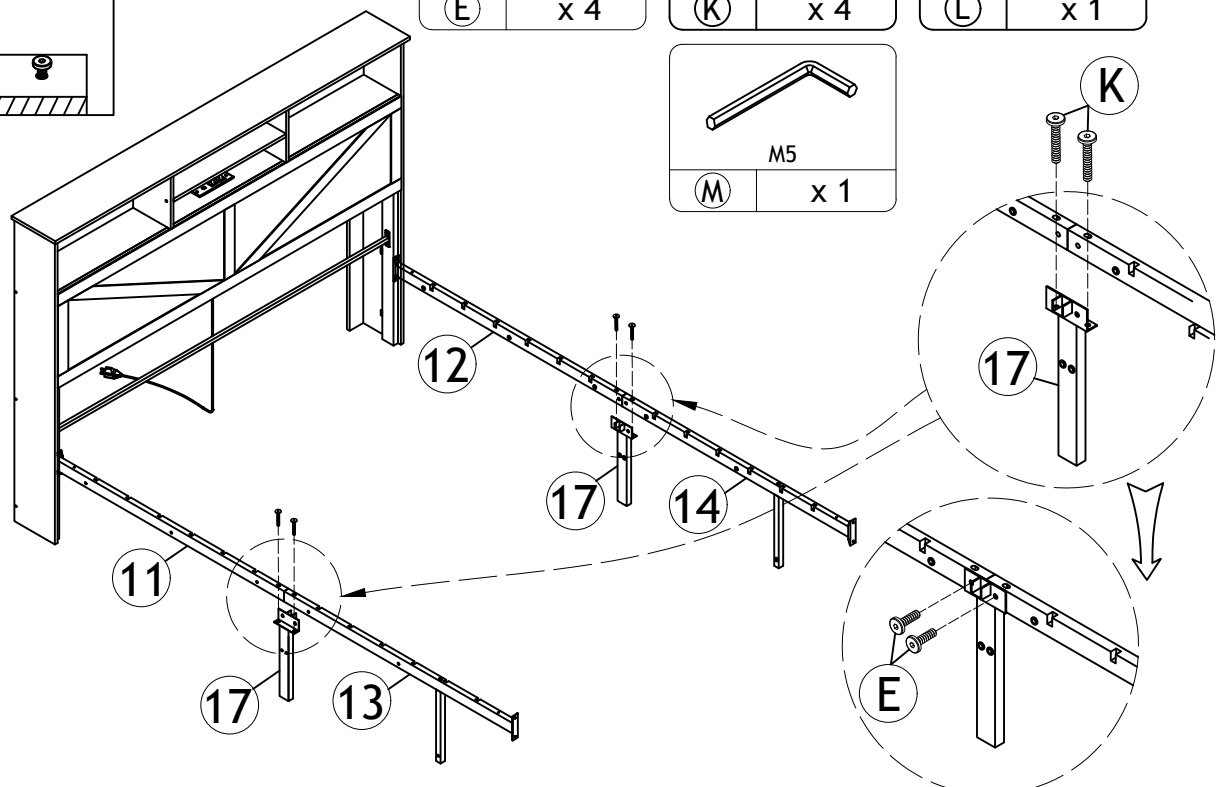

M5
 (M) x 1



STEP 19

 Please tighten the bolts to 80% first, and tighten all bolts 100% after all parts are assembled.

| | |
|---|---|
|  |  |
|---|---|

| |
|---|
|  |
| Ø1/4" x 11mm |
| (D) x 4 |

| |
|---|
|  |
| M4 |
| (L) x 1 |

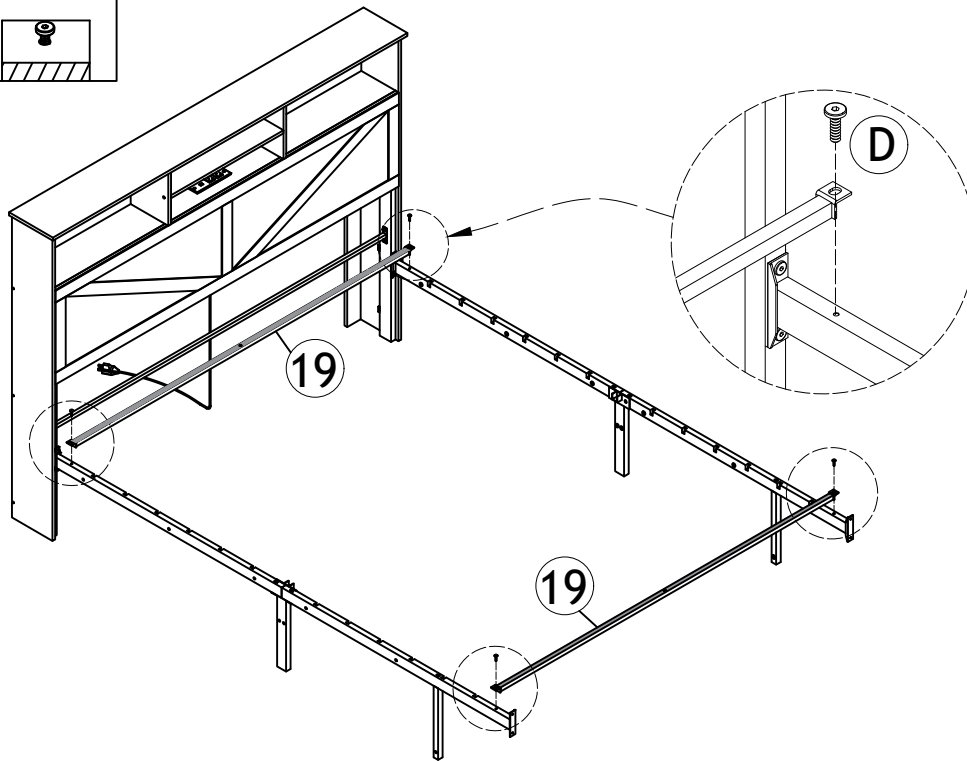

STEP 20

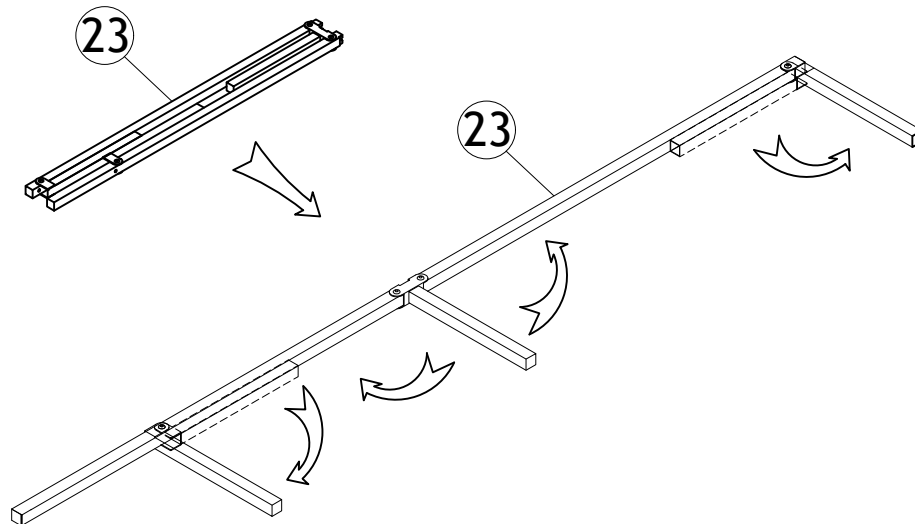

Expand the folded portion

STEP 21

⚠ Please tighten the bolts to 80% first, and tighten all bolts 100% after all parts are assembled.

Ø1/4" x 60mm
Ⓜ H x 2

M4
Ⓜ L x 1

Ø1/4" x 25mm
Ⓜ F x 1

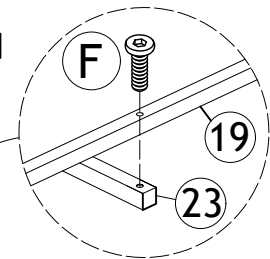
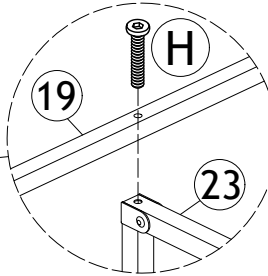
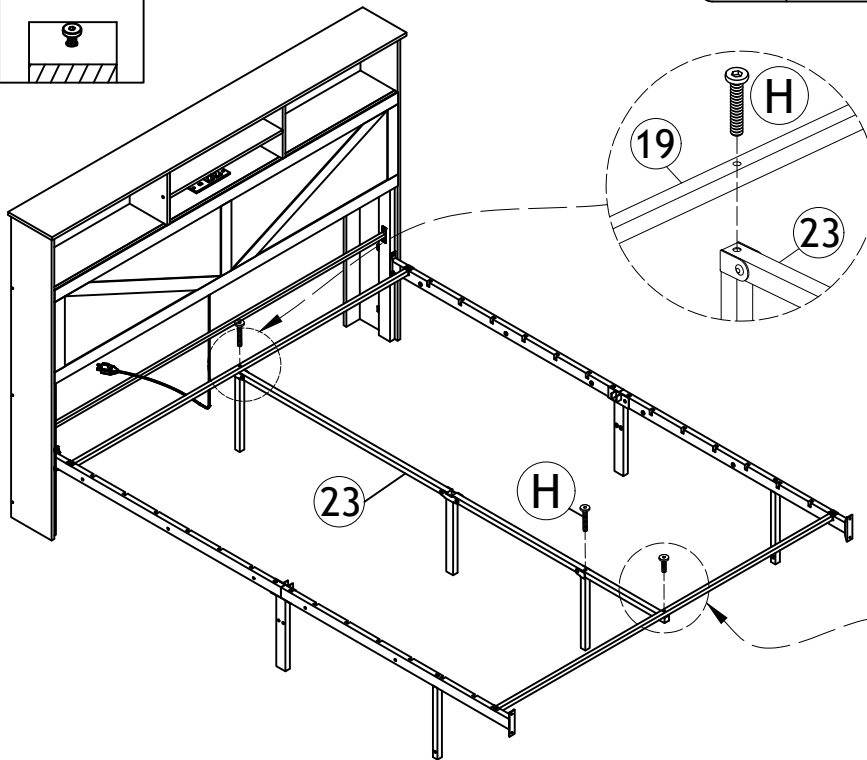

STEP 22

⚠ Please tighten the bolts to 80% first, and tighten all bolts 100% after all parts are assembled.

M8 x 28mm
Ⓜ J x 2

Ø1/4" x 60mm
Ⓜ H x 1

M4
Ⓜ L x 1

M5
Ⓜ M x 1

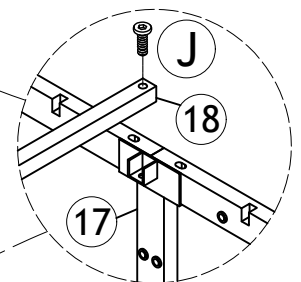
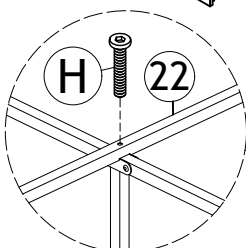
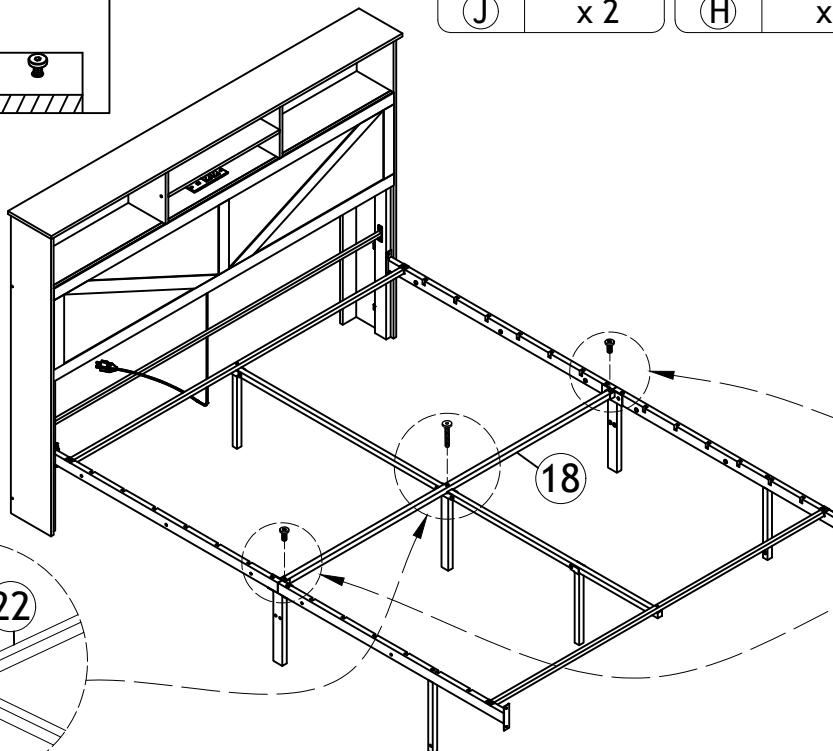

STEP 23

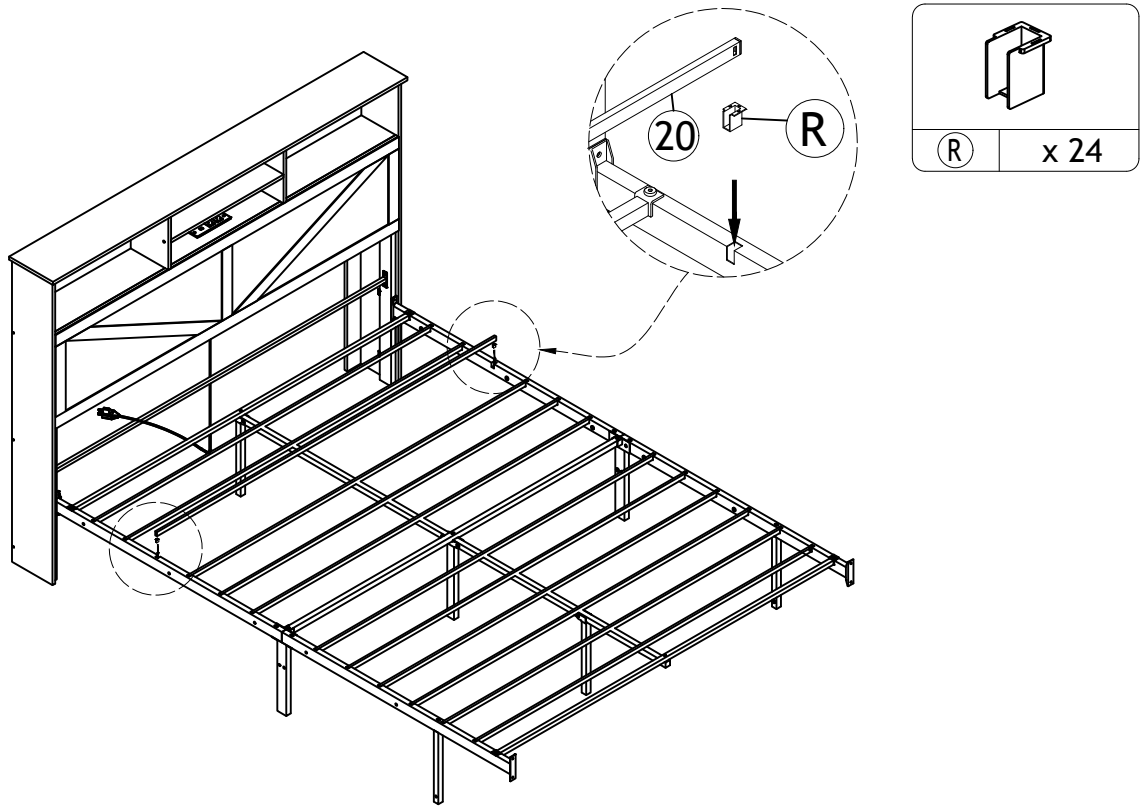

Assemble the slats

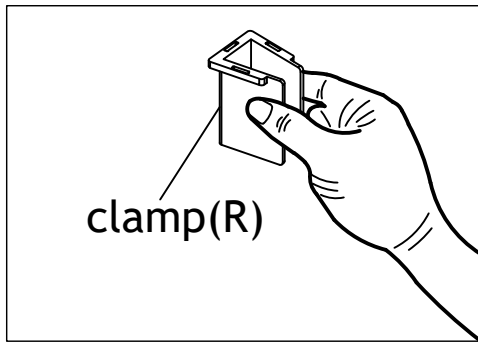

1. Squeeze the clamp (R) tightly.

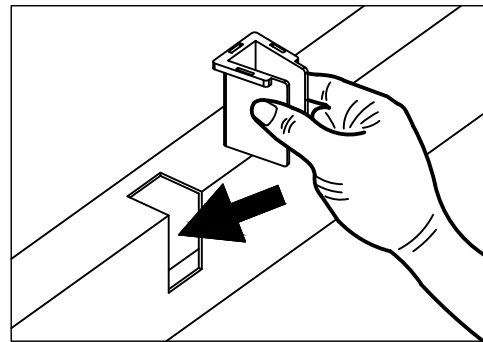

2. Put the clamp into the gaps.

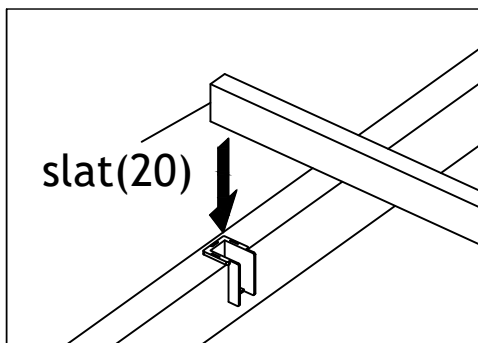

3. Put the slat (20) into the clamp.

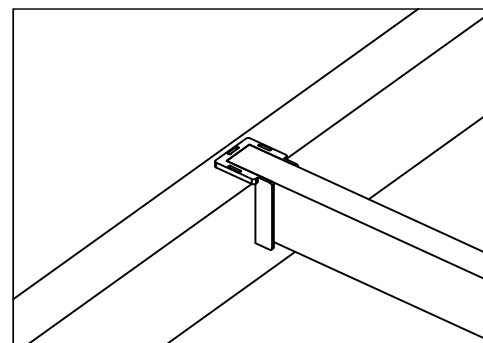

4. Finished.

STEP 24

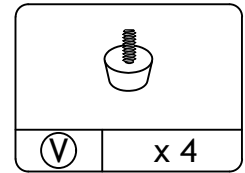
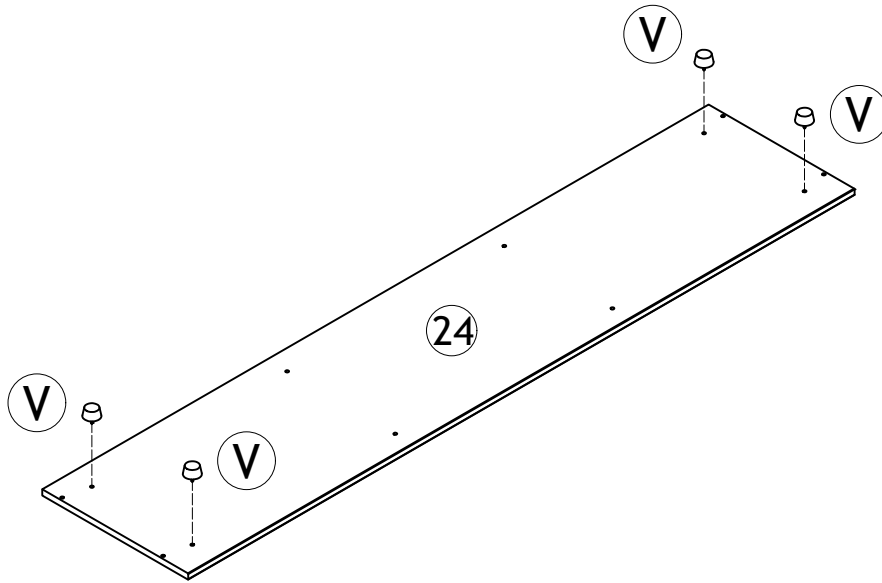

STEP 25

Please screws in this step need to be tightened

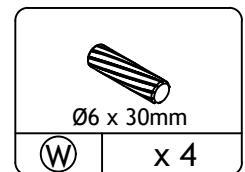
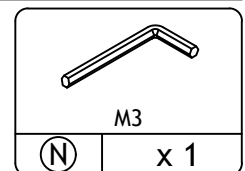
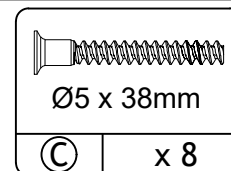
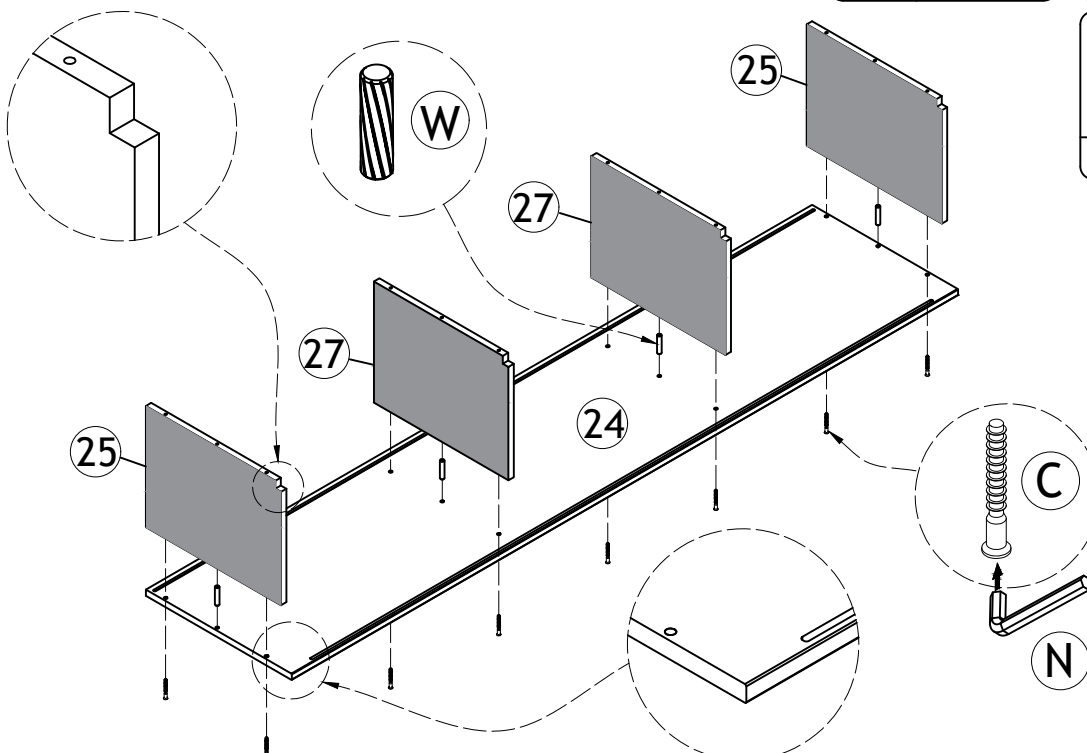

STEP 26

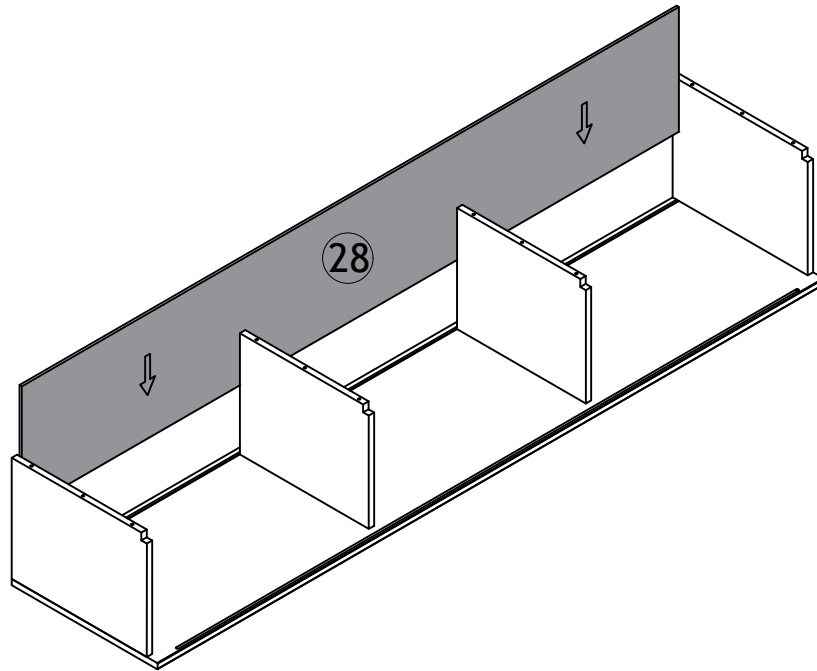

STEP 27

 Please screws in this step need to be tightened

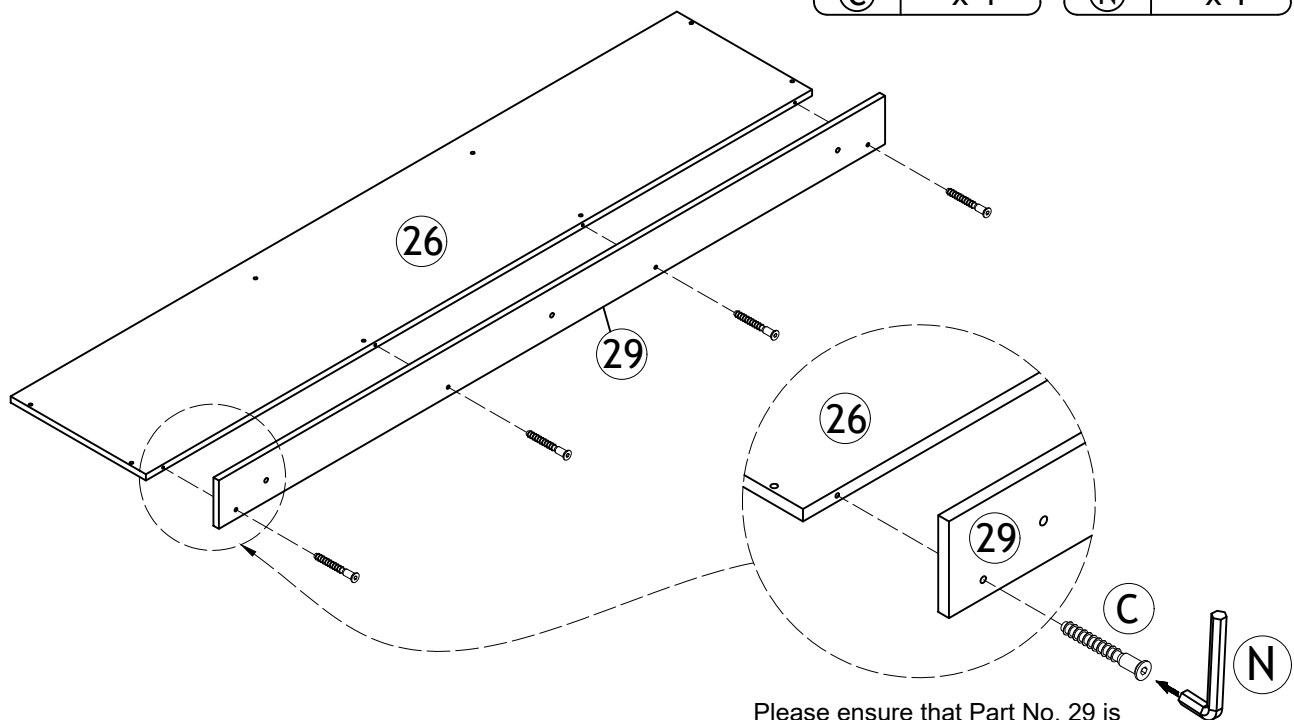
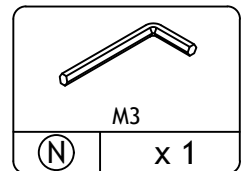
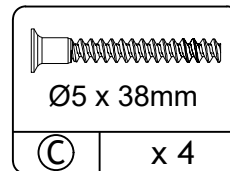



Please ensure that Part No. 29 is installed in the correct orientation

STEP 28

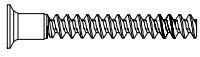
 Please screws in this step need to be tightened

| | |
|--|-----------|
|  | Ø5 x 38mm |
| (C) | x 8 |

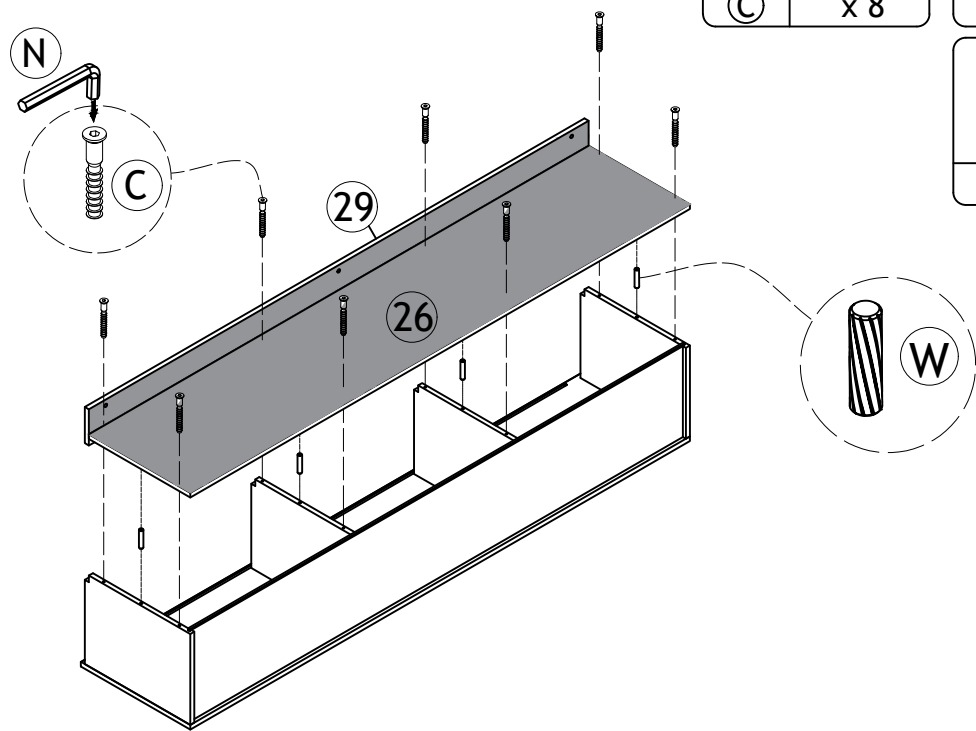

| | |
|---|-----|
|  | M3 |
| (N) | x 1 |

| | |
|---|-----------|
|  | Ø6 x 30mm |
| (W) | x 4 |





STEP 29

 Please tighten the bolts to 80% first, and tighten all bolts 100% after all parts are assembled.

| | |
|---|---|
|  |  |
|---|---|

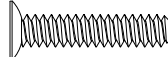
| | | |
|---|-----|-----|
|  | (T) | x 3 |
|---|-----|-----|

| | |
|---|--------------|
|  | Ø1/4" x 28mm |
| (I) | x 3 |

| | |
|---|-----|
|  | M4 |
| (L) | x 1 |

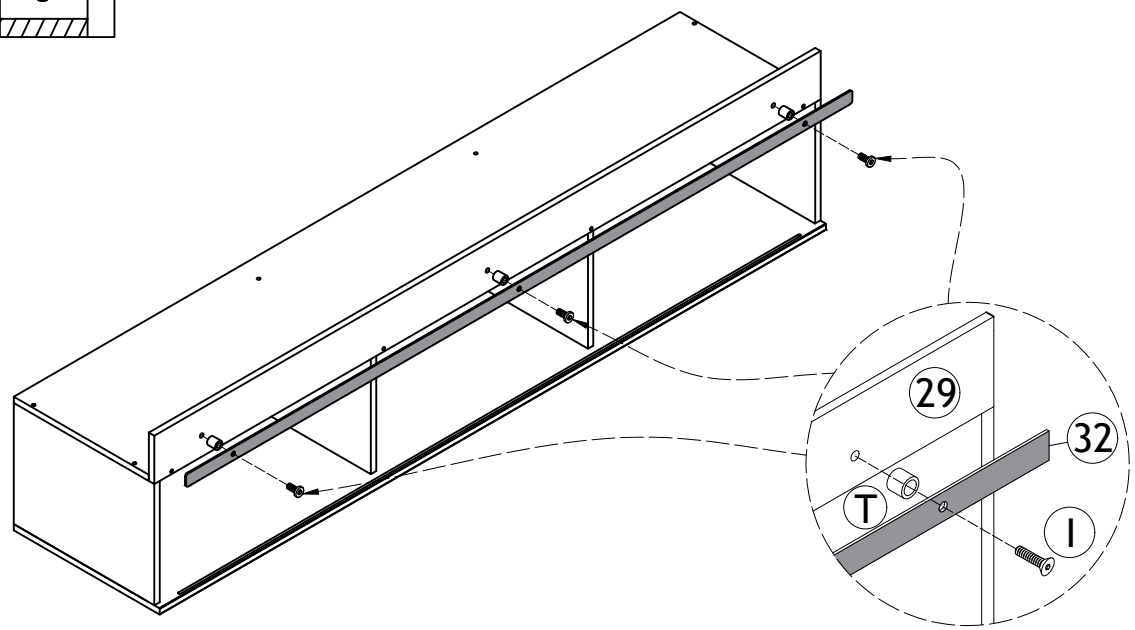

STEP 30

 Please screws in this step need to be tightened

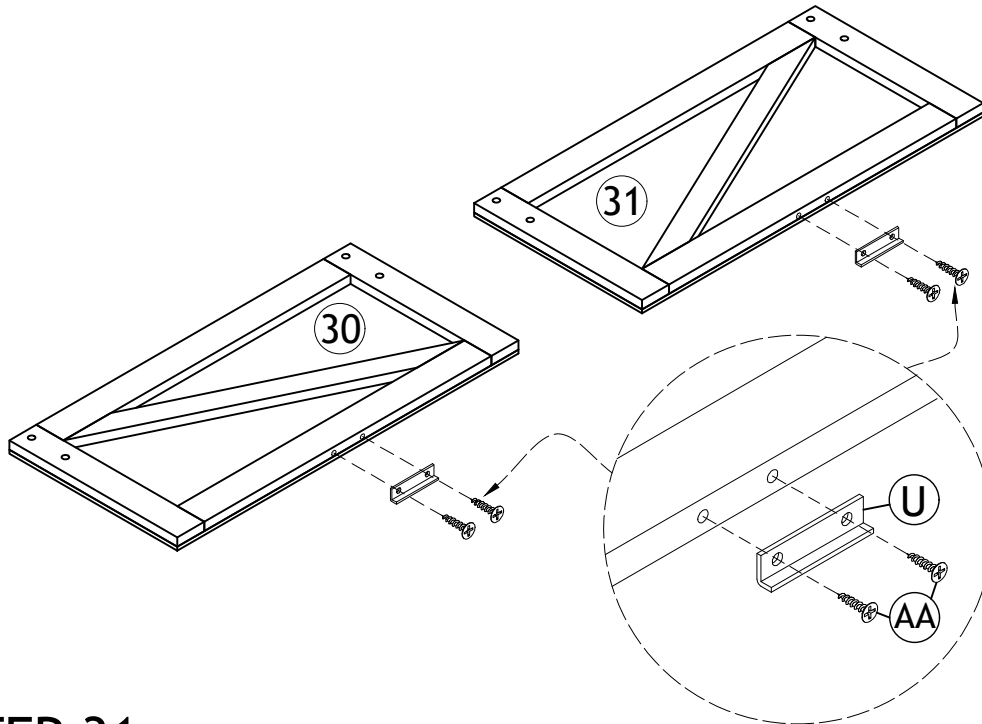
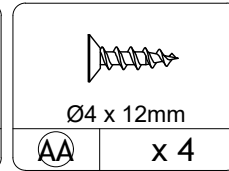
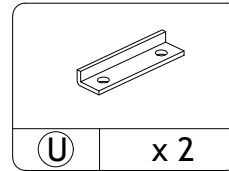
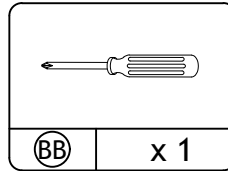

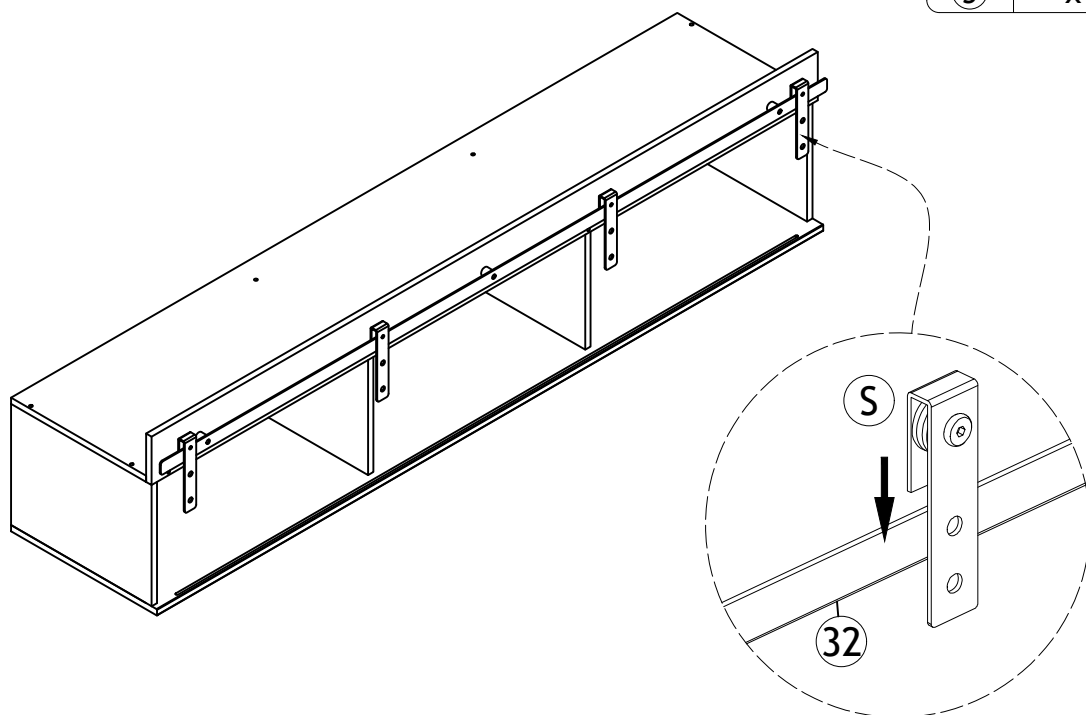
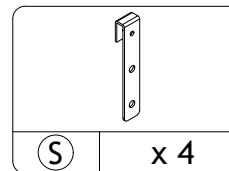

STEP 31

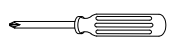

STEP 32

 Please screws in this step need to be tightened

| |
|---|
|  |
| (BB) x 1 |

| |
|---|
|  |
| Ø1/4" x 11mm |
| (D) x 8 |

| |
|---|
|  |
| M4 |
| (L) x 1 |

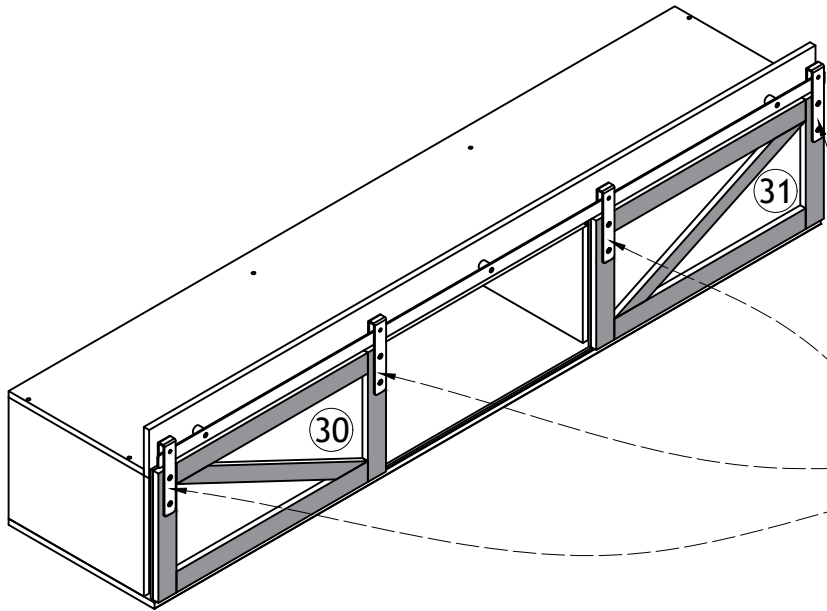

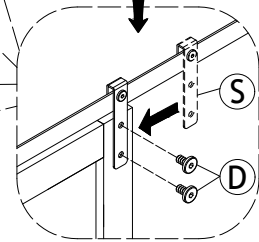
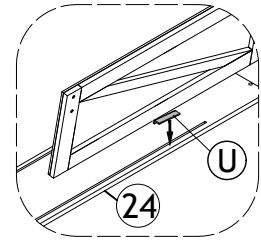

Insert metal plates (U) under door (30/31) into the groove on panel (24).



Connect door (30/31) metal pulley (S) with bolt(D)

STEP 33

 Please screws in this step need to be tightened

| |
|---|
|  |
| Ø1/4" x 11mm |
| (D) x 3 |

| |
|---|
|  |
| M4 |
| (L) x 1 |

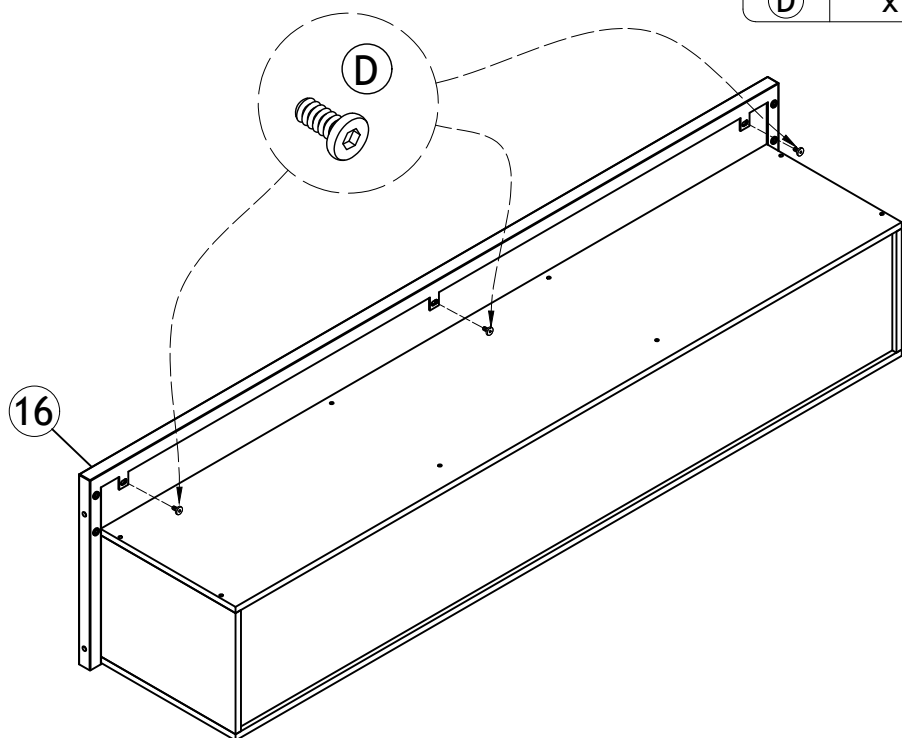

STEP 34

 Please screws in this step need to be tightened



Ø1/4" x 16mm
E x 4

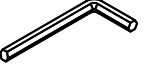

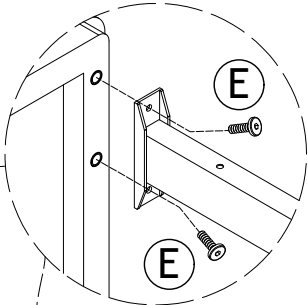
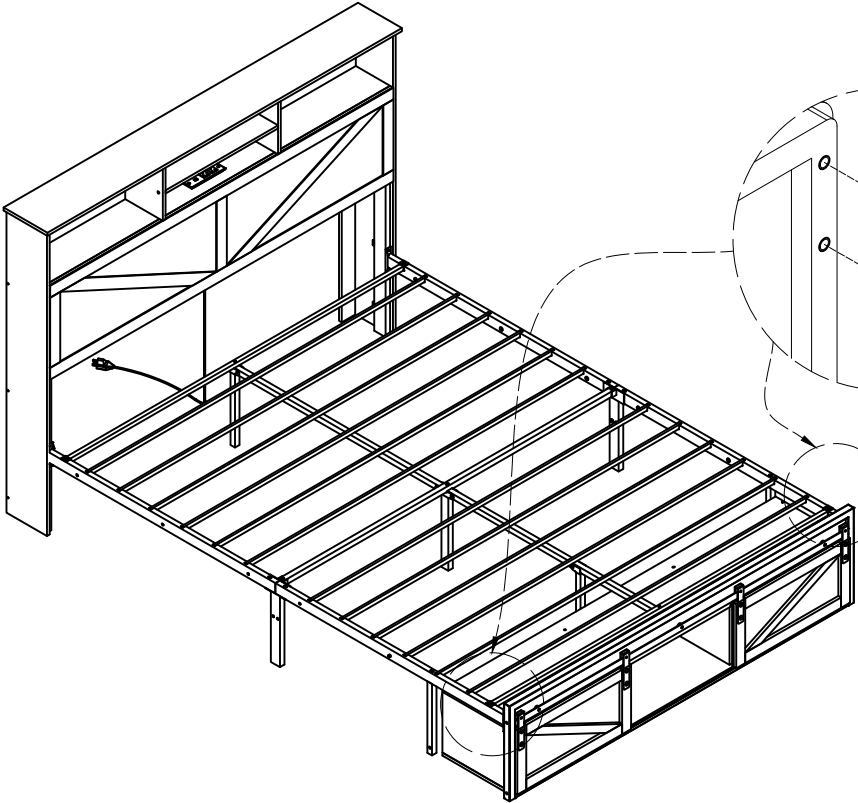
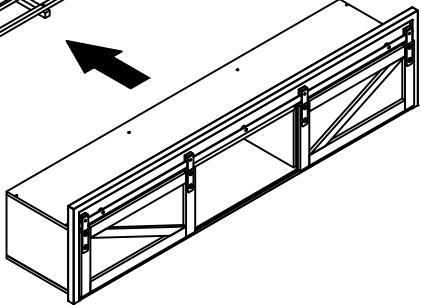
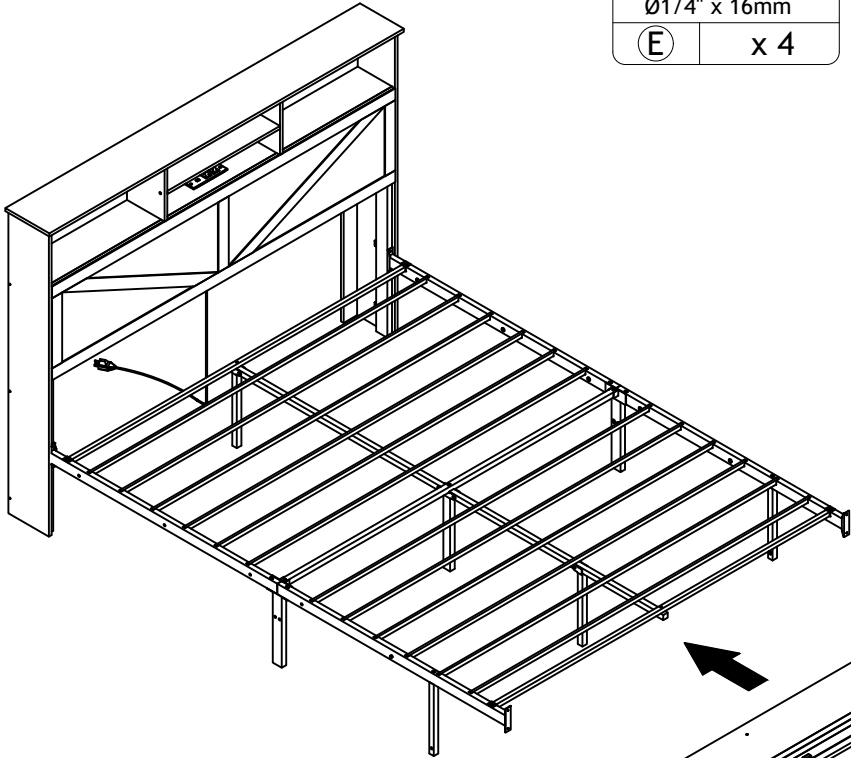

M4
L x 1



STEP 35

 Please tighten the bolts to 80% first, and tighten all bolts 100% after all parts are assembled.

| | |
|---|---|
|  |  |
|---|---|

| | |
|---|------|
|  | |
| Ø1/4" x 25mm | |
| (F) | x 20 |

| | |
|---|-----|
|  | |
| M4 | |
| (L) | x 1 |

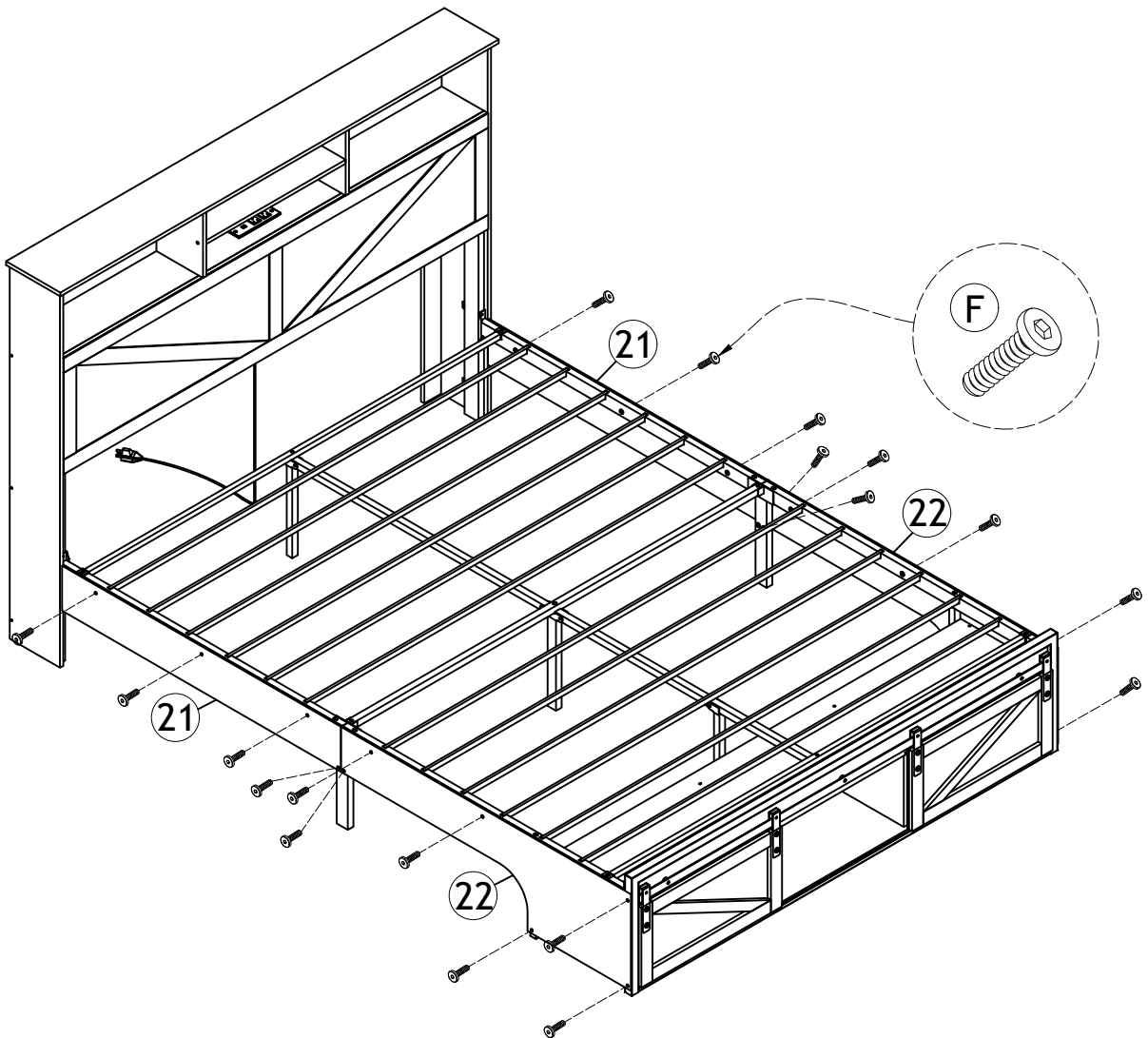

STEP 36

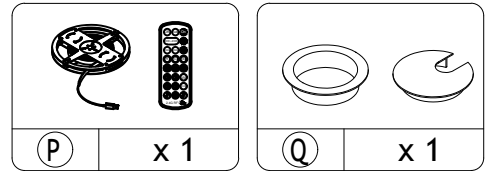
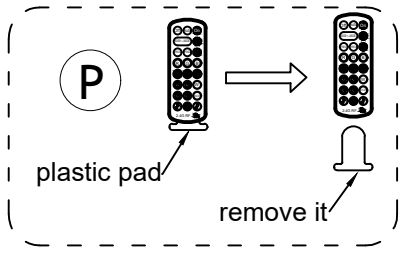

Please pull the plastic block out of the remote control.

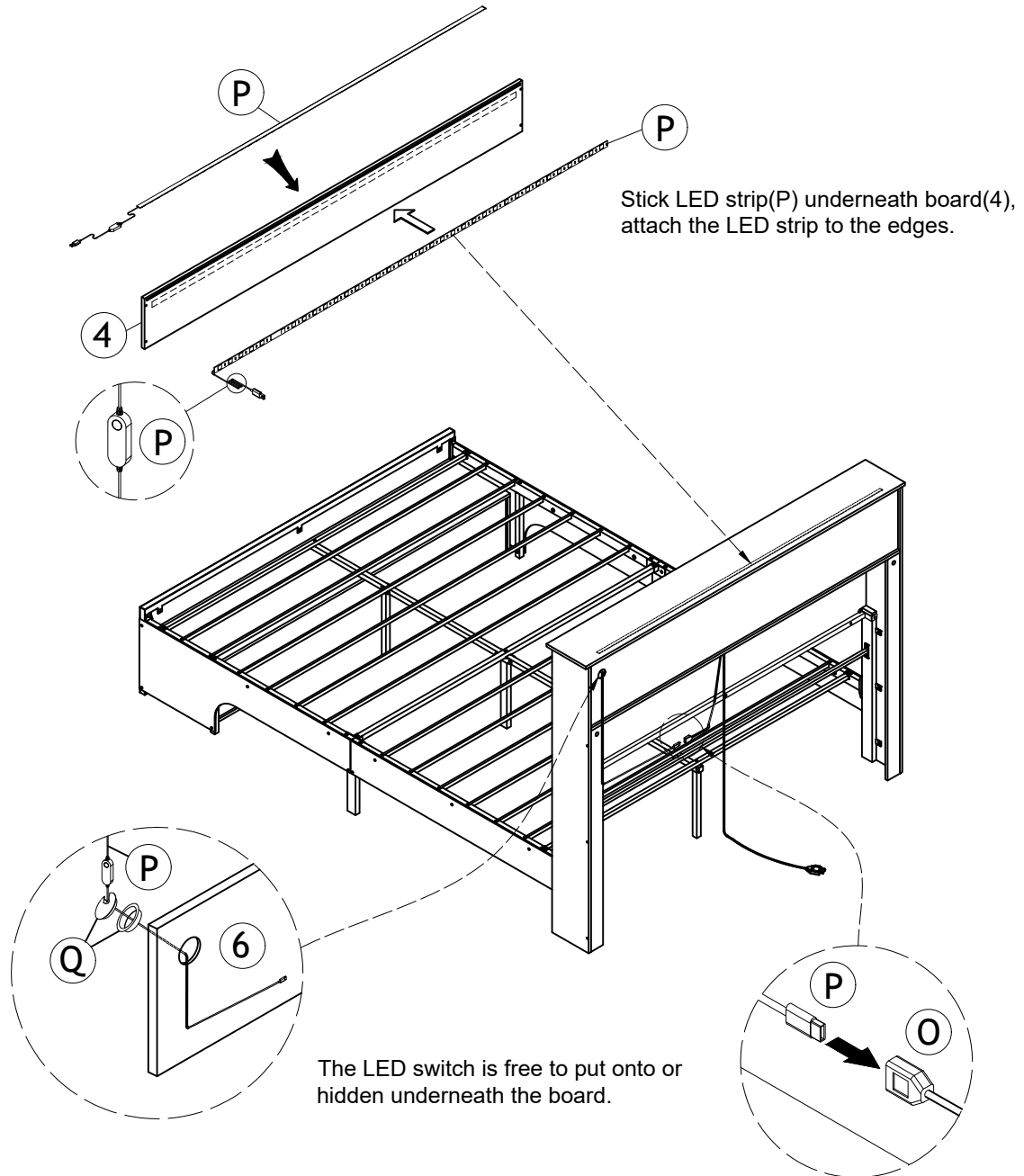

Congratulation:

Congratulations to you on completing the assembly of the product through your own efforts, you have done a great job.

The assembly of this product may have been difficult, but you still had the patience and perseverance to get it done.

Notes:

1. The product is designed for indoor use only and must be assembled and used according to the provided manual. Modifying or altering the product from its original design may result in personal injury or damage to the product.

Product Maintenance:

1. Please place this item on the level solid ground.
2. Avoid long-term exposure to humid environments to prevent mildew.
3. Keep the product away from high temperature environments or fire sources.
4. If accidentally spill water or another liquid on the surface, immediately wipe with a dry towel.
5. Regularly inspect the tightness of screws while using the product. If necessary, re-tighten to ensure structural stability.