

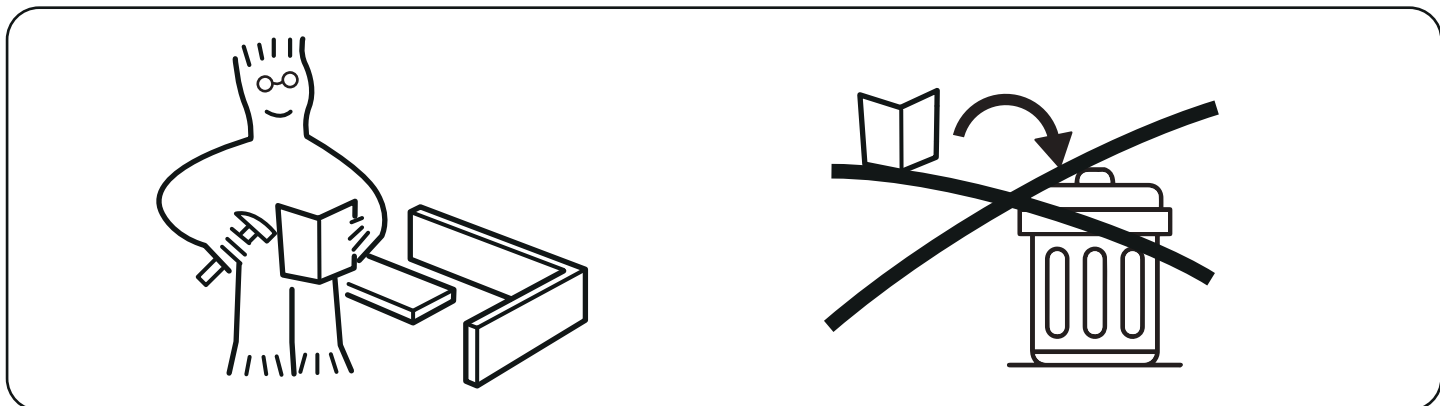

ASSEMBLY INSTRUCTIONS

NOTICE

IMPORTANT, RETAIN FOR FUTURE REFERENCE: READ CAREFULLY
WICHTIG, FÜR SPÄTERE NACHSCHLAGE AUFBEWAHREN: SORGFÄLTIG LESEN
IMPORTANTE, GUARDAR PARA REFERENCIA FUTURA: LEER ATENTAMENTE
IMPORTANTE, CONSERVARE PER RIFERIMENTI FUTURI: LEGGERE ATTENTAMENTE
IMPORTANT, À CONSERVER POUR RÉFÉRENCE FUTURE : LIRE ATTENTIVEMENT



Assemble on a flat, clean and soft surface.
Auf einer flachen, sauberen und weichen Oberfläche zusammenbauen.
Assembler sur une surface plate, propre et douce.
Assemblare su una superficie piatta, pulita e morbida.
Ensamblar sobre una superficie plana, limpia y suave.

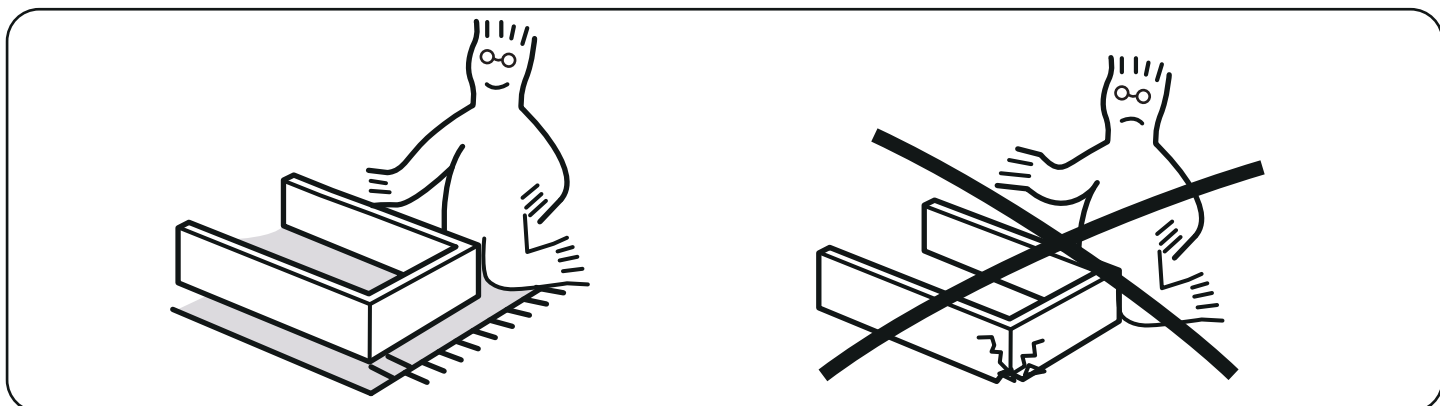

Professional installation is highly recommended.
Eine professionelle Installation wird dringend empfohlen.
Une installation professionnelle est fortement recommandée.
Si raccomanda vivamente l'installazione professionale.
Se recomienda altamente la instalación profesional.



Periodically Check That All Components Are Tightly Secured.
Überprüfen Sie Regelmäßig, Dass Alle Komponenten Fest Gesichert Sind.
Vérifiez Périodiquement Que Tous Les Composants Sont Bien Fixés.
Controllare Periodicamente Che Tutti I Componenti Siano Ben Fissati.
Verifique Periódicamente Que Todos Los Componentes Estén Bien Asegurados.

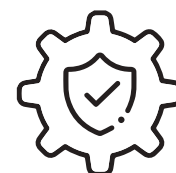

It is recommended that multiple people assemble this product.
Es wird empfohlen, dass mehrere Personen dieses Produkt zusammenbauen.
Il est recommandé que plusieurs personnes assemblent ce produit.
Si raccomanda che più persone assemblino questo prodotto.
Se recomienda que varias personas ensamblen este producto.

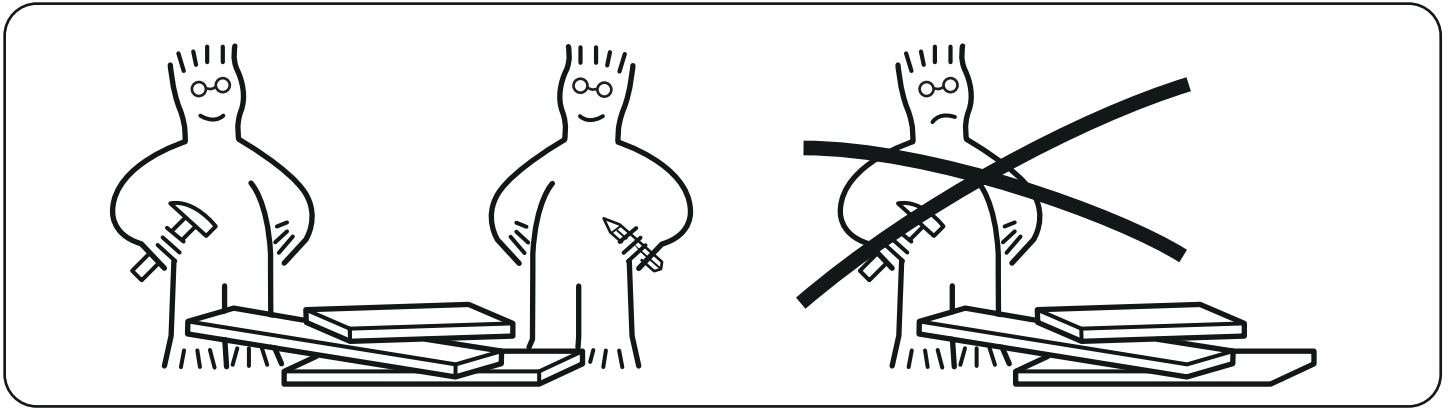

Please have the following auxiliary tools ready:

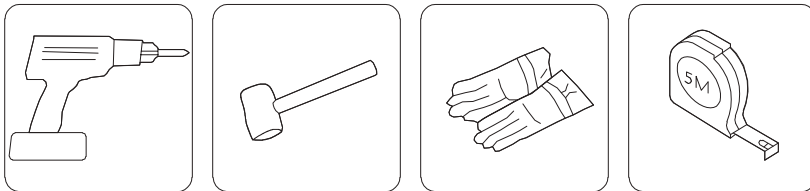

USING CAM LOCK AND QUICKFIT
 VERWENDUNG VON NOCKENSCHLOSS UND QUICKFIT
 UTILISATION DE SERRURE À CAME ET QUICKFIT
 USO DI SERRATURA A LEVA E QUICKFIT
 USANDO EL CIERRE DE LEVA Y QUICKFIT

Tighten QuickFit until the shoulder is flush with the panel. Do not overtighten or undertighten.
 Ziehen Sie den Quickfit an, bis die Schulter bündig mit der Platte ist. Nicht zu fest oder zu locker anziehen.
 Serrez le quickfit jusqu'à ce que l'épaulement soit affleurant avec le panneau. Ne serrez pas trop ou trop peu.
 Stringere il quickfit fino a quando la spalla è a filo con il pannello. Non stringere troppo o troppo poco.
 Apriete el quickfit hasta que el hombro esté al ras con el panel. No apriete demasiado ni demasiado poco.

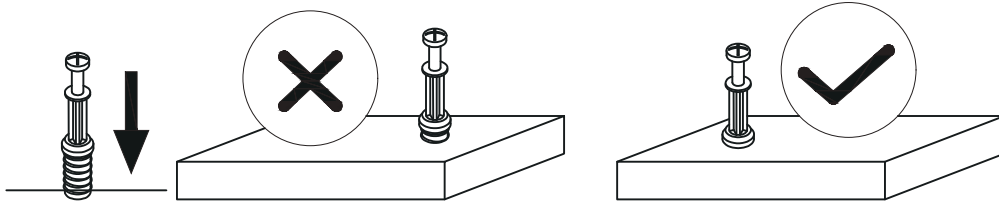

When fitting the cam lock, ensure the starting position is correct before inserting the connecting QuickFit.

Stellen Sie beim Einbau des nockenschloss sicher, dass die Startposition korrekt ist, bevor Sie den verbindenden Quickfit einsetzen.

Lors de la pose du serrure à came, assurez-vous que la position de départ est correcte avant d'insérer le quickfit de connexion.

Quando si monta il serratura a leva, assicurarsi che la posizione di partenza sia corretta prima di inserire il quickfit di collegamento.

Al instalar el cierre de leva, asegúrese de que la posición inicial sea correcta antes de insertar el quickfit de conexión.

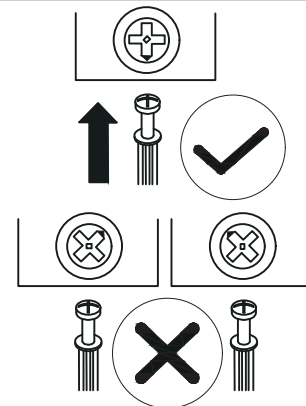

The QuickFit head should be in the center of the cam lock when the two panels are joined. The cam lock should be inserted before the QuickFit. Turn the cam lock clockwise to tighten.

Der Quickfit-Kopf sollte sich in der Mitte des nockenschloss befinden, wenn die beiden Platten verbunden sind. Der nockenschloss sollte vor dem Quickfit eingesetzt werden. Drehen Sie den nockenschloss im Uhrzeigersinn, um ihn zu befestigen.

La tête du quickfit doit être au centre du serrure à came lorsque les deux panneaux sont assemblés. Le serrure à came doit être inséré avant le quickfit. Tournez le serrure à came dans le sens des aiguilles d'une montre pour le serrer.

La testa del quickfit dovrebbe essere al centro del serratura a leva quando i due pannelli sono uniti. Il serratura a leva deve essere inserito prima del quickfit.

Ruotare il serratura a leva in senso orario per stringere.

La cabeza del quickfit debe estar en el centro del cam lock cuando los dos paneles estén unidos. El cierre de leva debe insertarse antes del quickfit. Gire el cierre de leva en sentido horario para apretar.

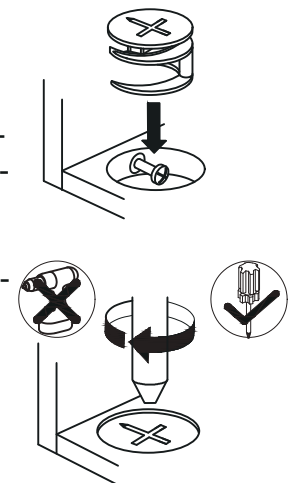

EN

PRE-FIXED DRAWER RUNNER INSTRUCTIONS

Pull inner and outer drawer runners apart before fixing them to panels.



Slide drawer runners apart until the drawer lock can be seen, as shown.

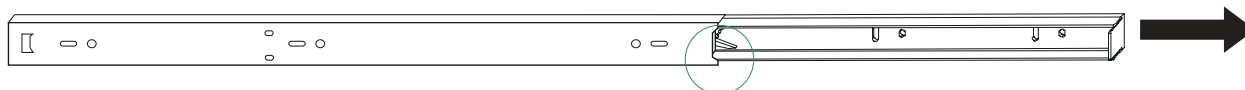

OUTER RUNNER

INNER RUNNER

Press and hold the drawer runner lock and then continue to slide drawer runners apart, as shown.

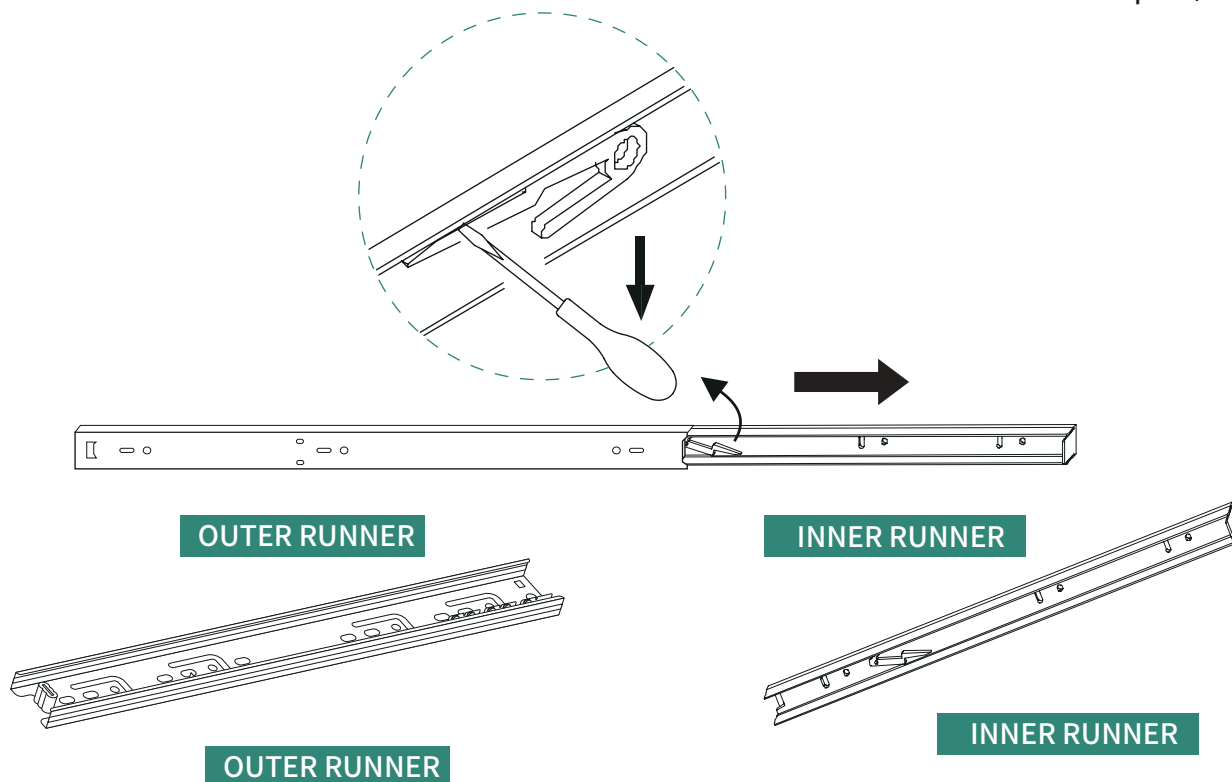

Your inner and outer drawer runners are ready to be fixed to panels.



OUTER RUNNER

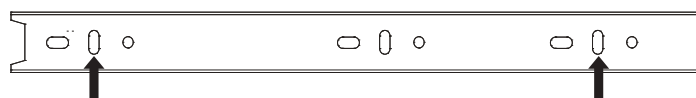

INNER RUNNER

! When installing the outer guide rail, please use the guide rail notch to assemble towards the inner direction of the drawer. Please fix the screws according to the marked position. If the installed position is changed, adjust it side-to-side at the marked position.

! When installing the inner guide rail, please use the guide rail notch to assemble towards the inner direction of the drawer. Please fix the screws according to the marked position. If the installed position is changed, adjust it up and down at the marked position.

DE

Vormontiert Schublade Führungsschiene Anweisungen

Ziehen Sie die inneren und äußeren Schubladenschienen auseinander, bevor Sie sie an den Paneelen befestigen.



Ziehen Sie die Schubladenläufer auseinander, bis das Schubladen-Schloss sichtbar wird, wie gezeigt.

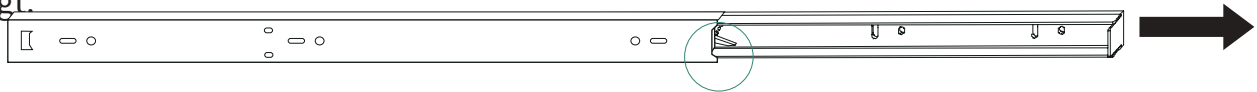

äußerer Schubladenauszug

innerer Schubladenauszug

Drücken und halten Sie den Schubladenschienen-Verschluss und schieben Sie dann wie gezeigt die Schubladenschienen auseinander.

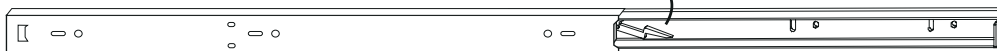
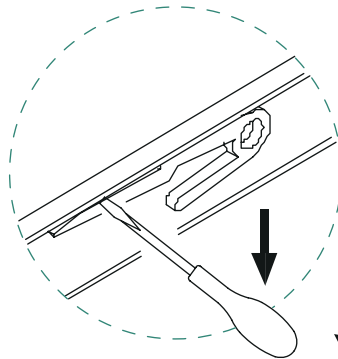

äußerer Schubladenauszug

innerer Schubladenauszug

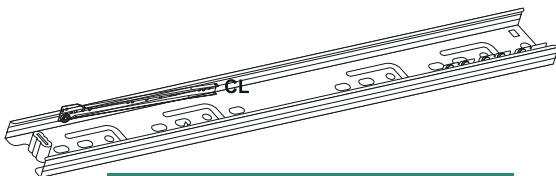

äußerer Schubladenauszug

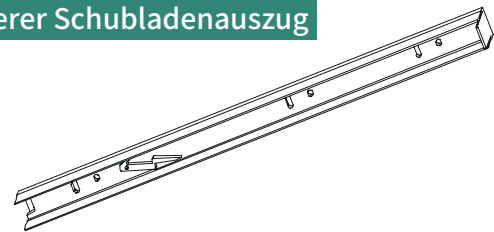

innerer Schubladenauszug

Ihre inneren und äußeren Schubladenschienen sind bereit, an den Paneelen befestigt zu werden.

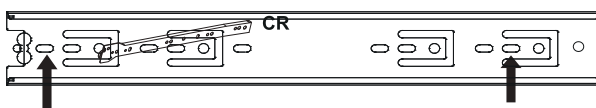

äußerer Schubladenauszug

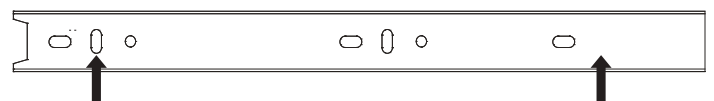

innerer Schubladenauszug



Bei der Installation der äußeren Führungsschiene verwenden Sie bitte die Führungsschienenkerbe, um in Richtung der inneren Schublade zu montieren. Befestigen Sie die Schrauben gemäß der markierten Position. Wenn sich die Installationsposition ändert, passen Sie sie seitlich an der markierten Position an.



Bei der Installation der inneren Führungsschiene verwenden Sie bitte die Führungsschienenkerbe, um in Richtung der inneren Schublade zu montieren. Befestigen Sie die Schrauben gemäß der markierten Position. Wenn sich die Installationsposition ändert, passen Sie sie in der markierten Position nach oben und unten an.

FR

Préfixé tiroir glissière instructions

Séparez les glissières intérieures et extérieures du tiroir avant de les fixer aux panneaux.



Écartez les coulisses du tiroir jusqu'à ce que le verrou de tiroir soit visible, comme indiqué.

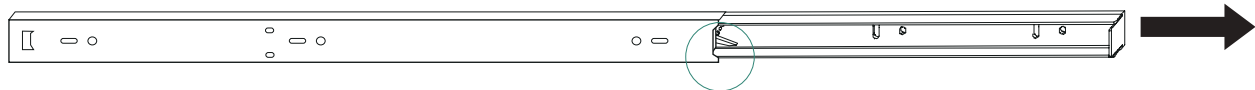

glissière extérieure

glissière intérieure

Appuyez sur la serrure de la glissière du tiroir et maintenez-la enfoncée, puis continuez à faire glisser les glissières du tiroir, comme indiqué.

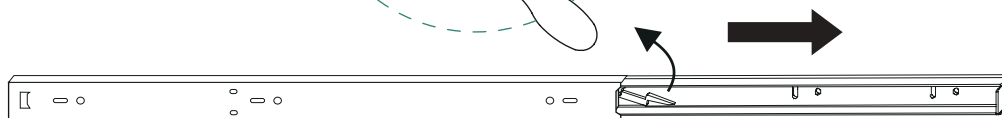
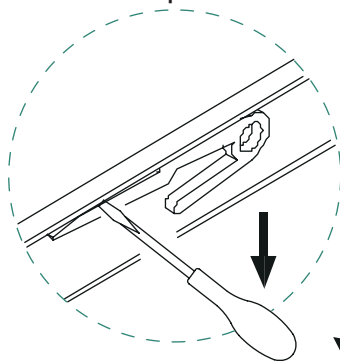

glissière extérieure

glissière intérieure

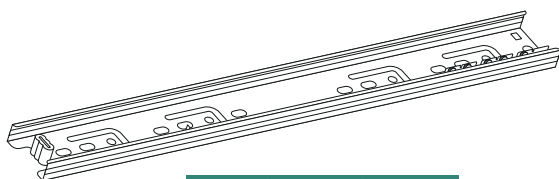

glissière extérieure

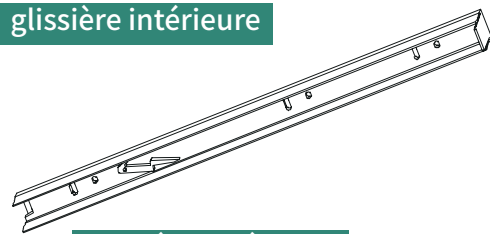

glissière intérieure

Vos glissières intérieures et extérieures de tiroir sont prêtes à être fixées aux panneaux.



glissière extérieure

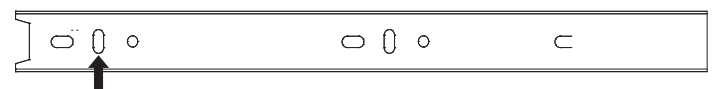

glissière intérieure

! Lors de l'installation du rail de guidage extérieur, veuillez utiliser l'encoche du rail de guidage pour l'assembler vers la direction intérieure du tiroir. Fixez les vis selon la position marquée. Si la position d'installation est modifiée, ajustez-la latéralement à la position marquée.

! Lors de l'installation du rail de guidage intérieur, veuillez utiliser l'encoche du rail de guidage pour l'assembler vers la direction intérieure du tiroir. Fixez les vis selon la position marquée. Si la position d'installation est modifiée, ajustez-la en haut et en bas à la position marquée.

IT

Prefissato cassetto guida istruzioni

Separare i guide interne ed esterne del cassetto prima di fissarle ai pannelli.



Scorri i guide del cassetto fino a quando la serratura del cassetto diventa visibile, come mostrato.

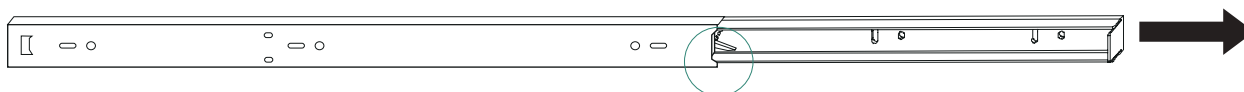

guida esterna

guida interna

Premere e tenere premuto il blocco delle guide del cassetto e poi continuare a far scorrere le guide del cassetto, come indicato.

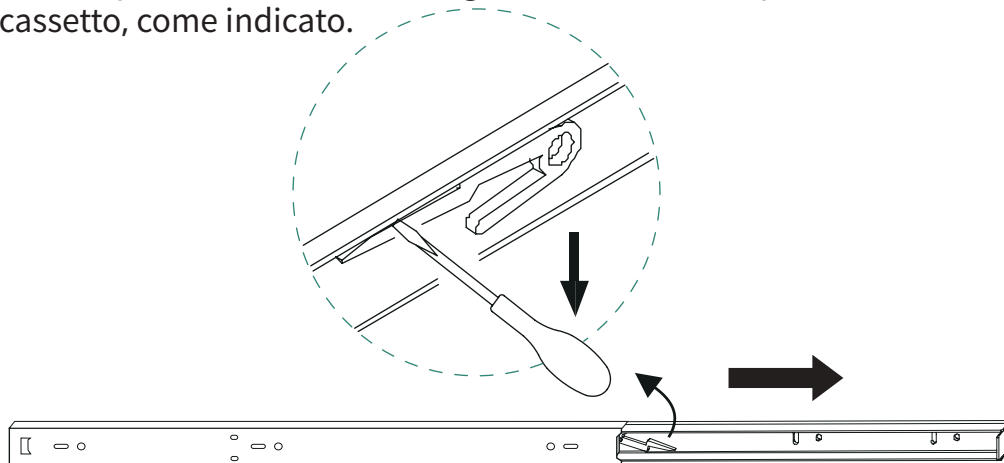

guida esterna

guida interna

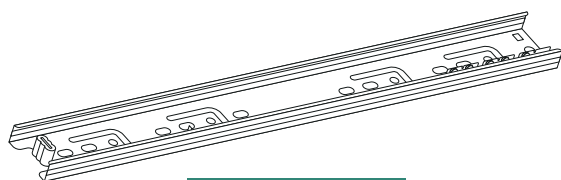

guida esterna

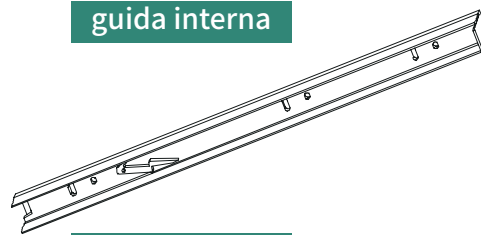

guida interna

Le vostre guide interne ed esterne del cassetto sono pronte per essere fissate ai pannelli.

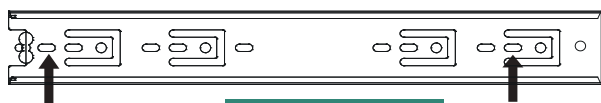

guida esterna

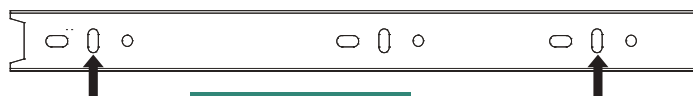

guida interna



Durante l'installazione della guida esterna, utilizzare l'incavo della guida per assemblare in direzione interna del cassetto. Fissare le viti secondo la posizione indicata. Se la posizione di installazione viene modificata, regolare lateralmente nella posizione indicata.



Durante l'installazione della guida interna, utilizzare l'incavo della guida per assemblare in direzione interna del cassetto. Fissare le viti secondo la posizione indicata. Se la posizione di installazione viene modificata, regolare su e giù nella posizione indicata.

ES

Prefijado cajón corredera instrucciones

Separe las correderas internas y externas del cajón antes de fijarlas a los paneles.



Separe los rieles del cajón hasta que se pueda ver la cerradura del cajón, como se muestra.

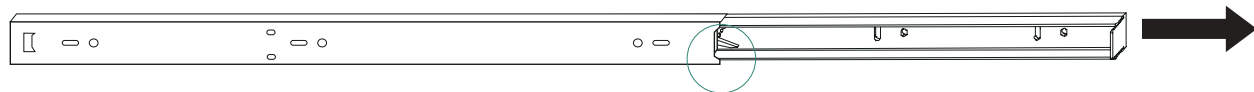

corredera exterior

corredera interior

Presione y mantenga presionado el bloqueo de la corredera del cajón y luego continúe deslizando las correderas del cajón, como se muestra.

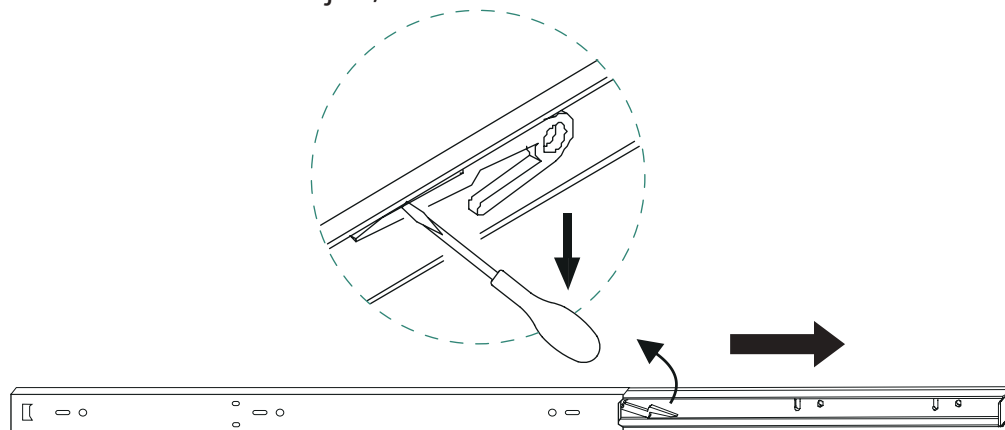

corredera exterior

corredera interior

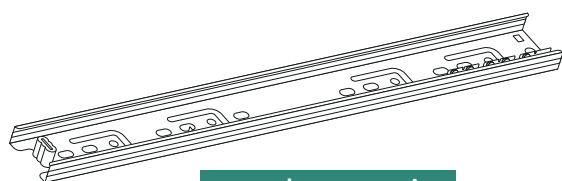

corredera exterior

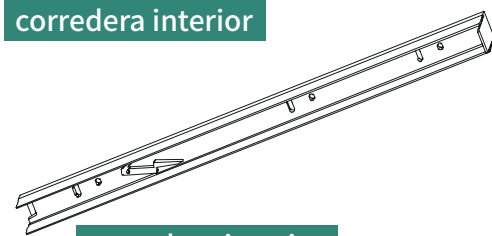

corredera interior

Sus correderas internas y externas del cajón están listas para ser fijadas a los paneles.



corredera exterior



Al instalar el riel de guía exterior, utilice la muesca del riel de guía para ensamblarlo hacia la dirección interna del cajón. Fije los tornillos según la posición marcada. Si cambia la posición instalada, ajústela lateralmente en la posición marcada.

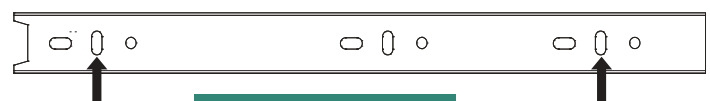

corredera interior



Al instalar el riel de guía interior, utilice la muesca del riel de guía para ensamblarlo hacia la dirección interna del cajón. Fije los tornillos según la posición marcada. Si cambia la posición instalada, ajústela hacia arriba y hacia abajo en la posición marcada.

Serious or fatal crushing injuries can occur from furniture tip-over. Always secure this furniture to the wall using tip-over restraints.

Schwere oder tödliche Quetschverletzungen können durch das Umkippen von Möbeln verursacht werden. Sichern Sie diese Möbel immer mit Kipp-Sicherungen an der Wand.

Des blessures graves ou mortelles par écrasement peuvent survenir en cas de basculement de meubles. Fixez toujours ces meubles au mur à l'aide de dispositifs anti-basculement.

Lesioni gravi o mortali da schiacciamento possono verificarsi a causa del ribaltamento dei mobili. Fissare sempre questi mobili alla parete utilizzando i sistemi di blocco anti-ribaltamento.

Pueden ocurrir lesiones graves o fatales por aplastamiento debido al volcamiento de muebles. Siempre asegure este mueble a la pared utilizando dispositivos anti-vuelco.

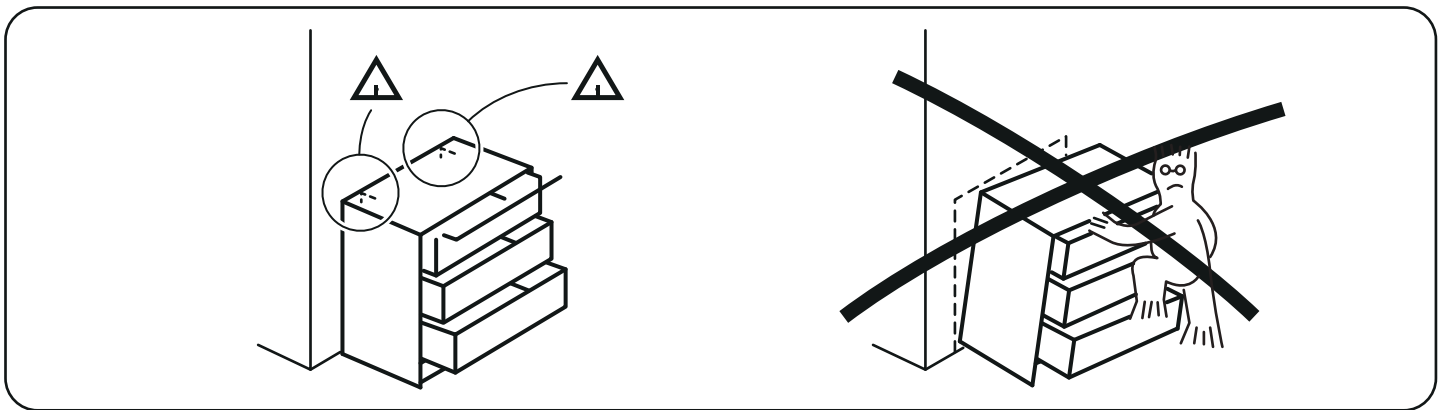

Never let children climb or hang on drawers, doors, or shelves.

Lassen Sie Kinder niemals auf Schubladen, Türen oder Regalen klettern oder hängen.

Ne laissez jamais les enfants grimper ou se suspendre aux tiroirs, portes ou étagères.

Non permettere mai ai bambini di arrampicarsi o appendersi ai cassetti, alle porte o agli scaffali.







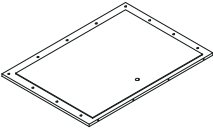
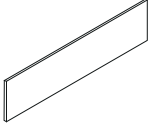
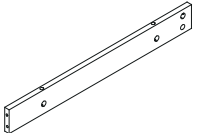
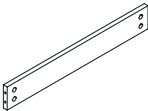
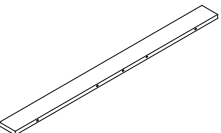
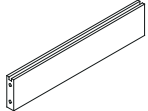
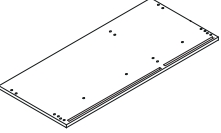
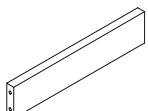
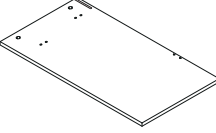
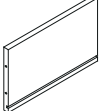
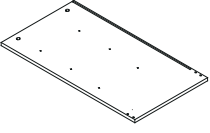
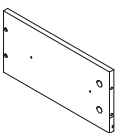
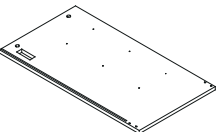
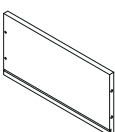

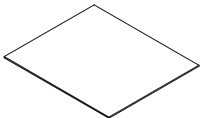
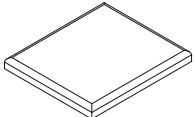
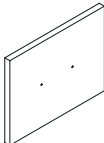
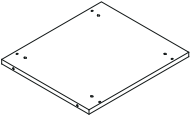
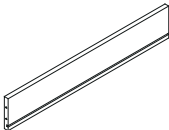
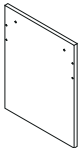
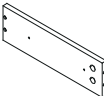
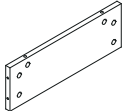
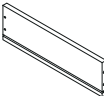
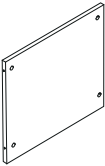
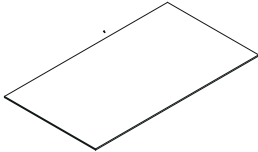
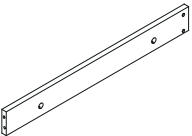
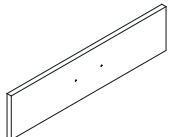
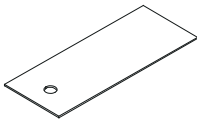

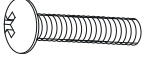
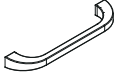
Nunca permita que los niños trepen o se cuelguen de los cajones, puertas o estantes.

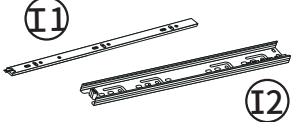

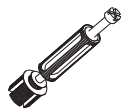
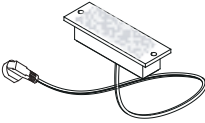

PARTS

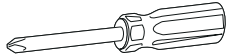
Item no. Nr. N° d'article Articolo No. Artículo No.	Reference Image Referenzbild Image de référence Immagine di riferimento Imagen de referencia	Qty. Menge Qté. Qtà Cant.	Item no. Nr. N° d'article Articolo No. Artículo No.	Reference Image Referenzbild Image de référence Immagine di riferimento Imagen de referencia	Qty. Menge Qté. Qtà Cant.
1		X1	8		X1
2		X1	9		X1
3		X1	10		X1
4		X1	11		X1
5		X1	12		X3
6		X1	13		X3
7		X1	14		X3

Item no. Nr. N° d'article Articolo No. Artículo No.	Reference Image Referenzbild Image de référence Immagine di riferimento Imagen de referencia	Qty. Menge Qté. Qtà Cant.	Item no. Nr. N° d'article Articolo No. Artículo No.	Reference Image Referenzbild Image de référence Immagine di riferimento Imagen de referencia	Qty. Menge Qté. Qtà Cant.
15		X3	22		X1
16		X3	23		X1
17		X1	24		X2
18		X1	25		X2
19		X1	26		X1
20		X1	27		X1
21		X1	28		X1

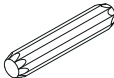
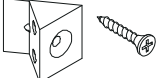
Item no. Nr. N° d'article Articolo No. Artículo No.	Reference Image Referenzbild Image de référence Immagine di riferimento Imagen de referencia	Qty. Menge Qté. Qtà Cant.	Item no. Nr. N° d'article Articolo No. Artículo No.	Reference Image Referenzbild Image de référence Immagine di riferimento Imagen de referencia	Qty. Menge Qté. Qtà Cant.
A	 M4 X 15MM	X8	H		X4
B	 M4 X 30MM	X4	I		X8
C	 M3.5 X 35MM	X16 + 2extra	K	 M3.5 X 12MM	X32 + 2extra
D	 M3.5 X 14MM	X4	M		X1
E	 X59 + 3extra	X59 + 3extra	N		X1
F	 M15 X 9.5MM	X59 + 3extra	O		X1
G	 M7 X 50MM	X7	P		X1

Item no. Nr. N° d'article Articolo No. Artículo No.	Reference Image Referenzbild Image de référence Immagine di riferimento Imagen de referencia	Qty. Menge Qté. Qtà Cant.
Q		X2
R		X22 + 1extra
S		X8

Item no. Nr. N° d'article Articolo No. Artículo No.	Reference Image Referenzbild Image de référence Immagine di riferimento Imagen de referencia	Qty. Menge Qté. Qtà Cant.
T		X11
U		X1

EXPLODED VIEW

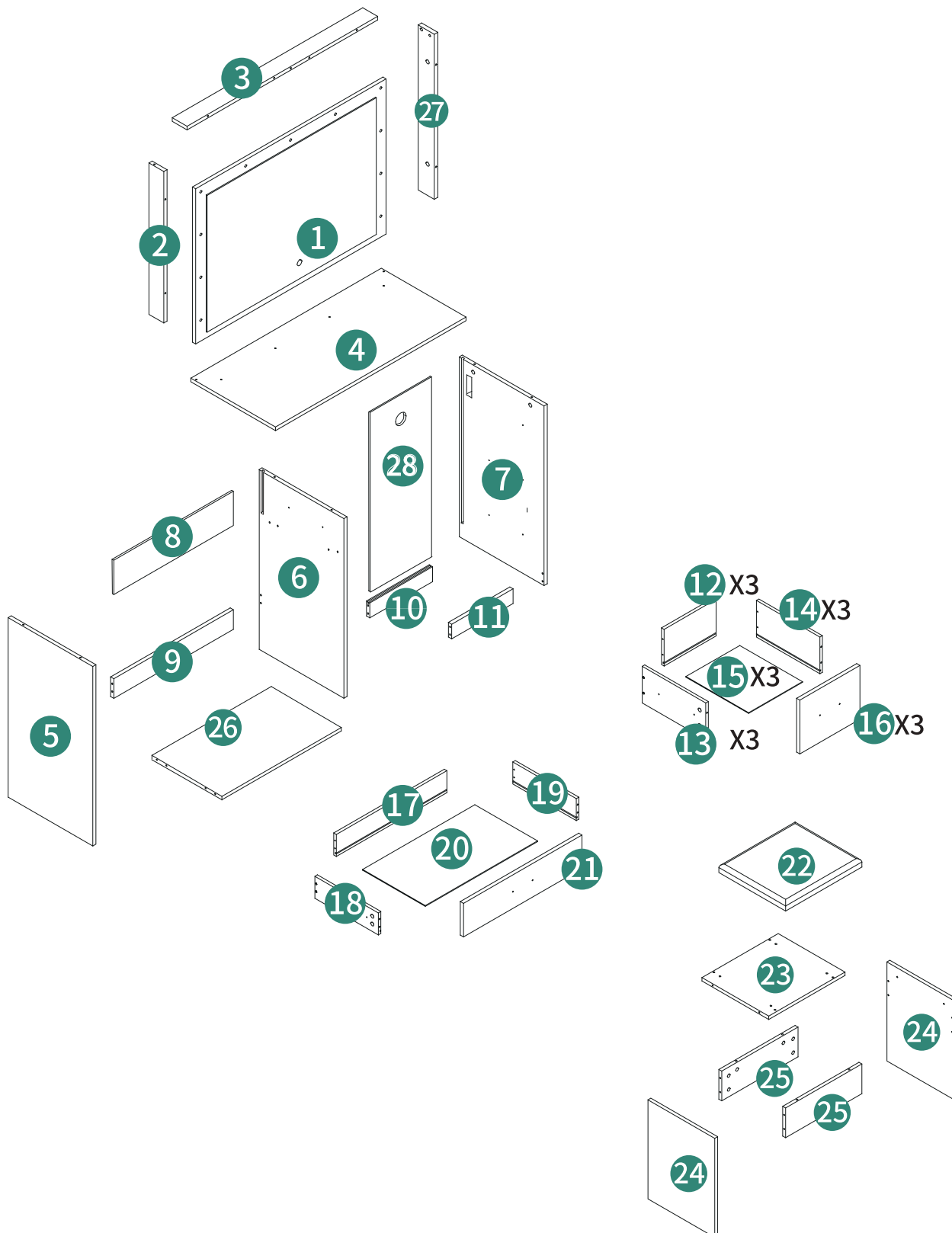

ASSEMBLY

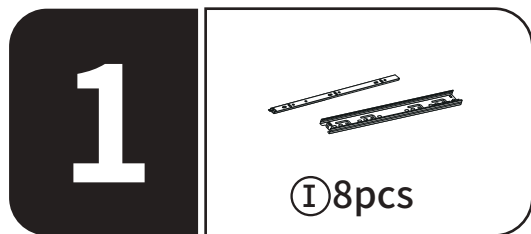

1-1

Press and hold the drawer runner lock and then continue to slide drawer runners apart, as shown.
Drücken und halten Sie den Schubladenschienen-Verschluss und schieben Sie dann wie gezeigt die Schubladenschienen auseinander.

Appuyez sur la serrure de la glissière du tiroir et maintenez-la enfoncée, puis continuez à faire glisser les glissières du tiroir, comme indiqué.

Premere e tenere premuto il blocco delle guide del cassetto e poi continuare a far scorrere le guide del cassetto, come indicato.

Presione y mantenga presionado el bloqueo de la corredera del cajón y luego continúe deslizando las correderas del cajón, como se muestra.

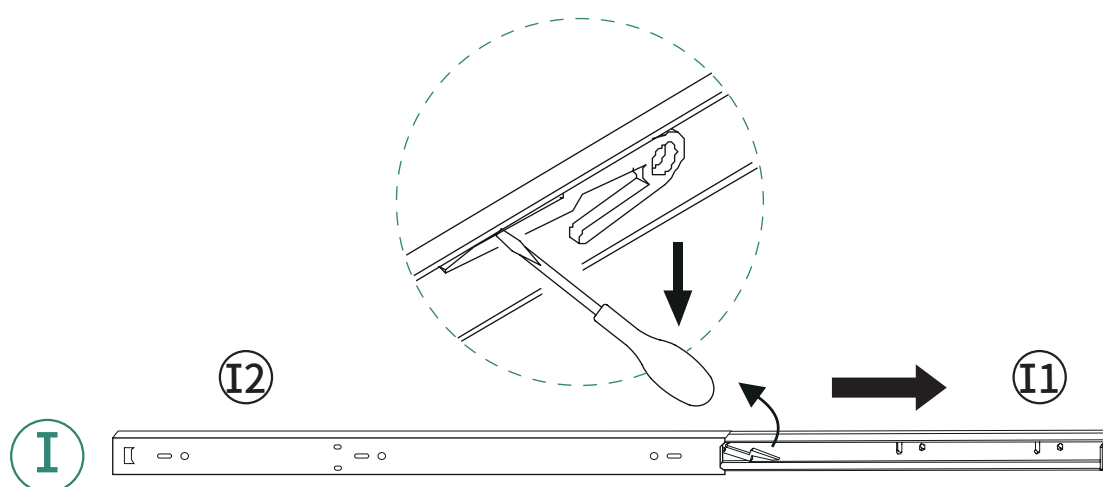

2

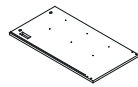

⑦ 1pc



⑥ 6pcs



② 2pcs



④ 4pcs



⑧ 8pcs



④ 4pcs

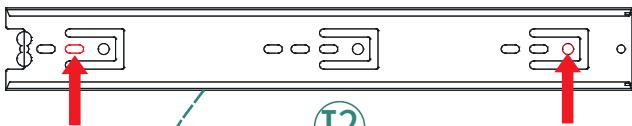

④

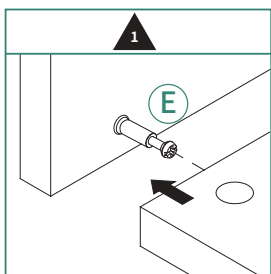
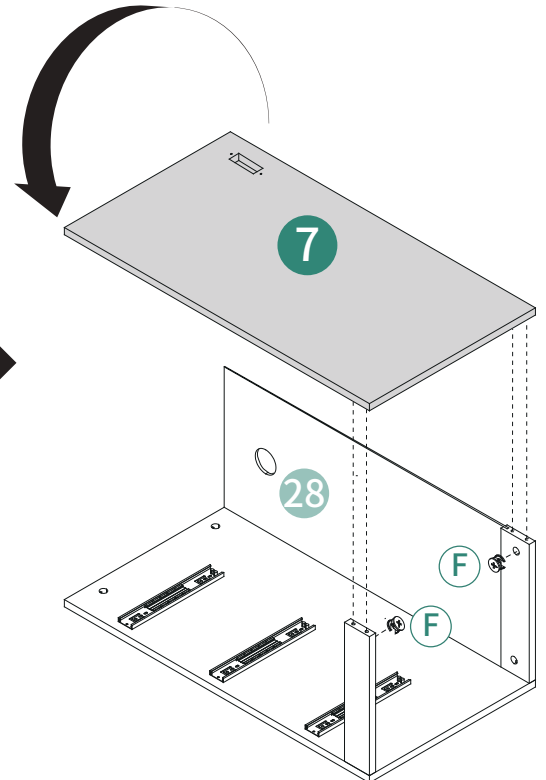
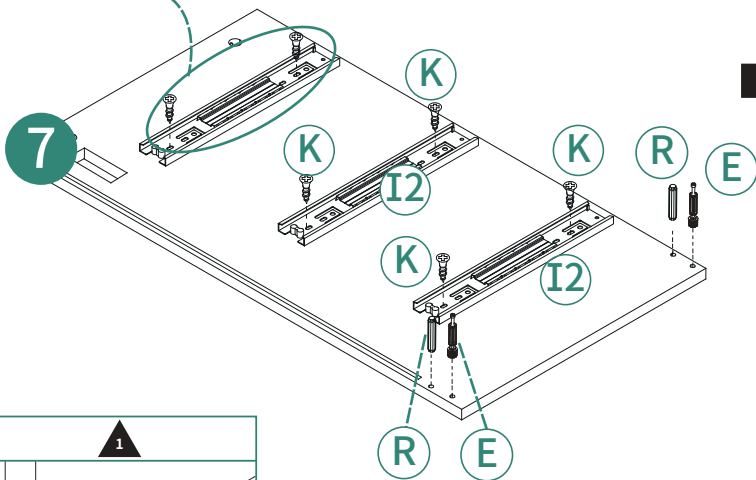

1

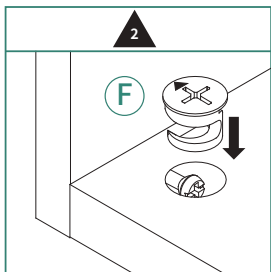

2

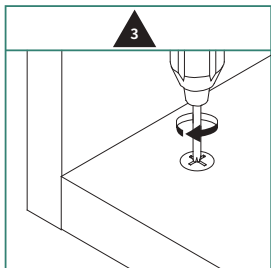

3

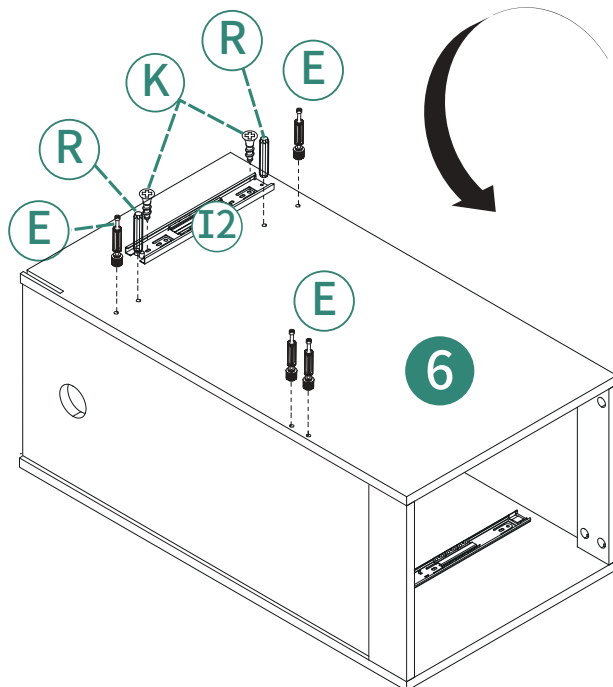
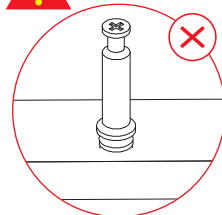
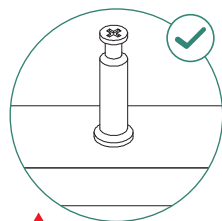

3



⑤1pc ⑧1pc ⑨1pc ⑳261pc ④E4pcs ⑧F8pcs ②R2pcs ②K2pcs ①I21pc

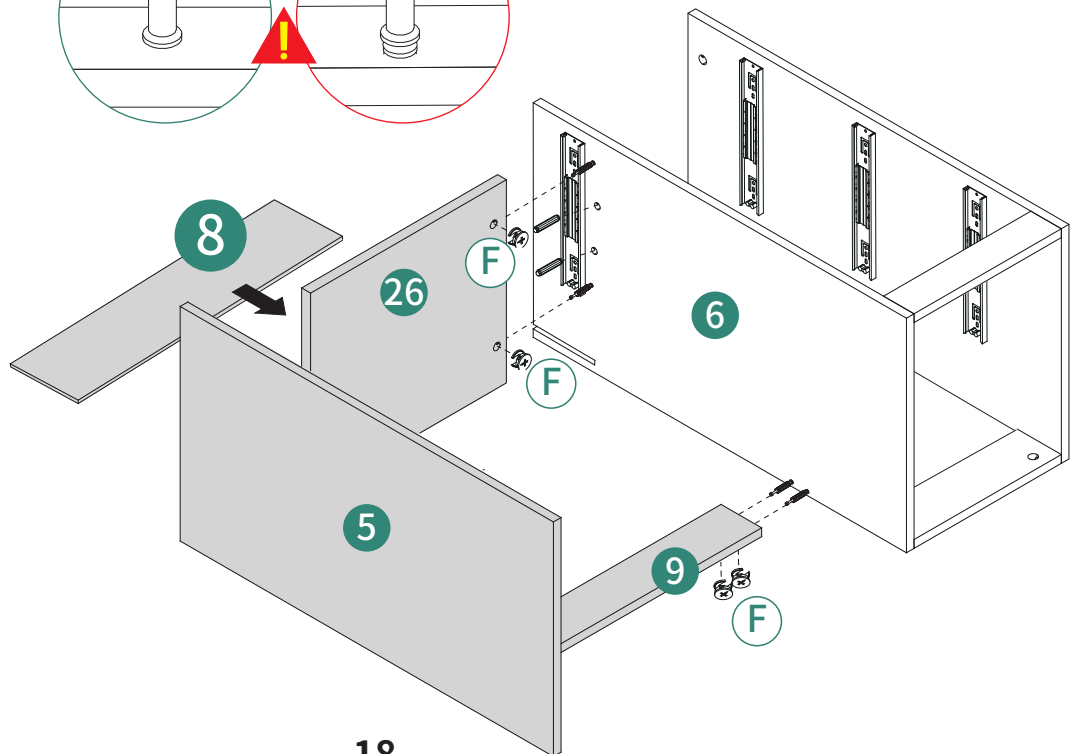
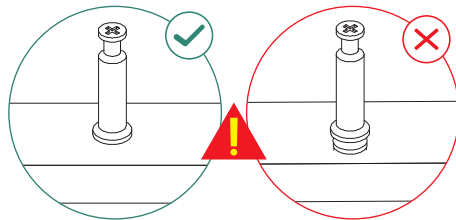
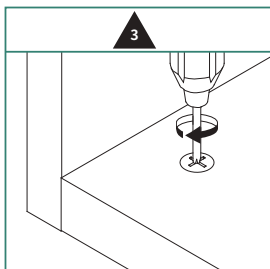
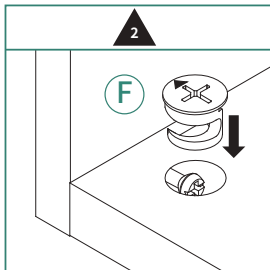
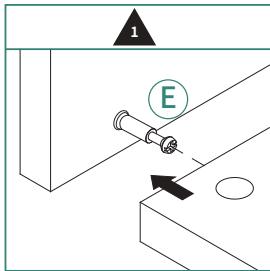
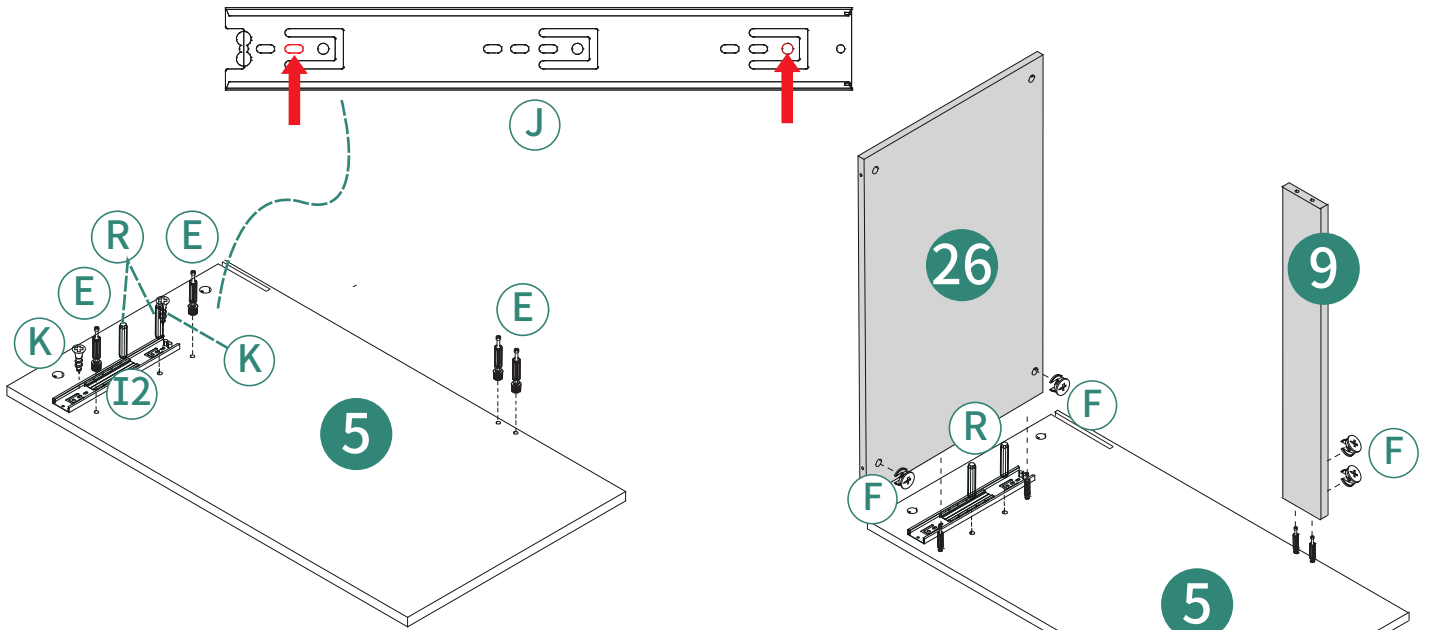

4

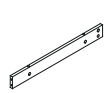

② 1pc



③ 1pc

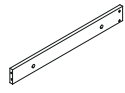

②7 1pc



ⓔ 2pcs



Ⓡ 2pcs



ⓕ 2pcs

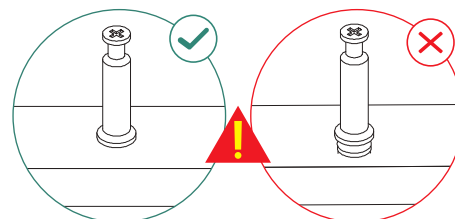
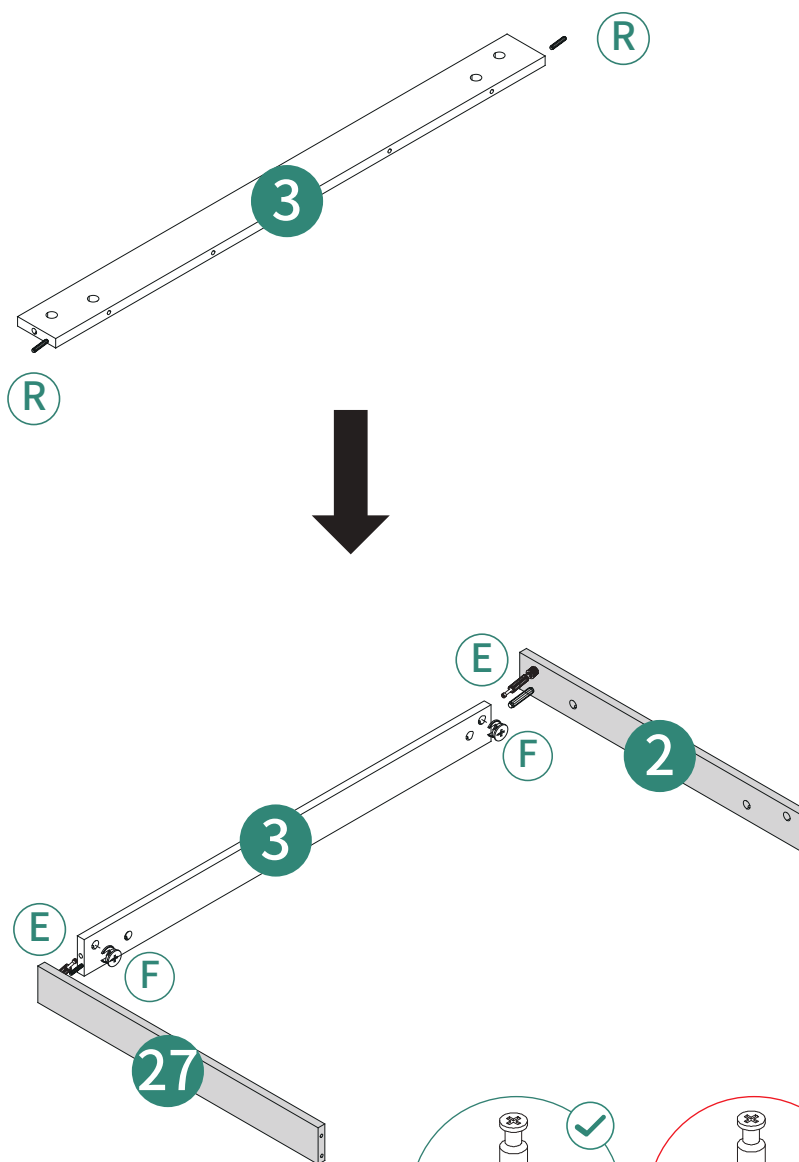
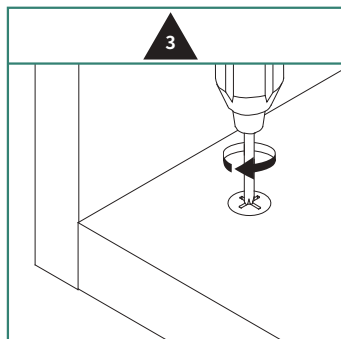
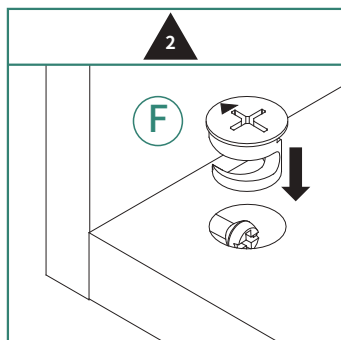
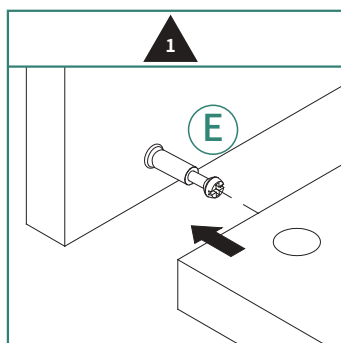

5

①1pc ⑦7pcs ④4pcs ⑦7pcs

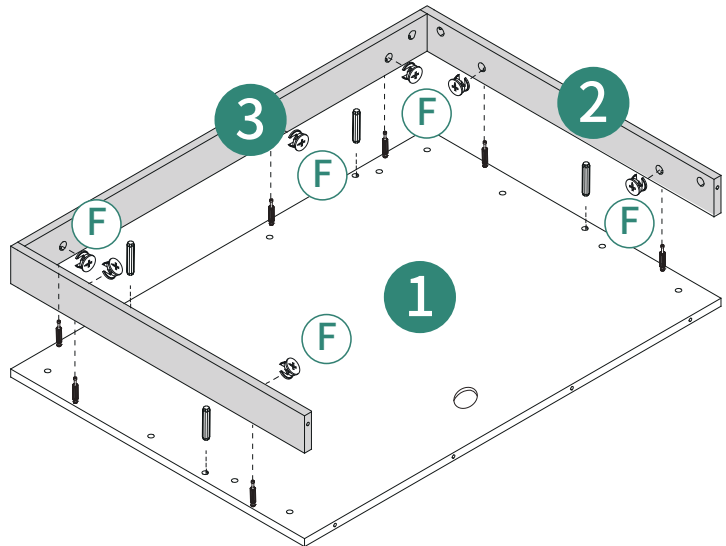
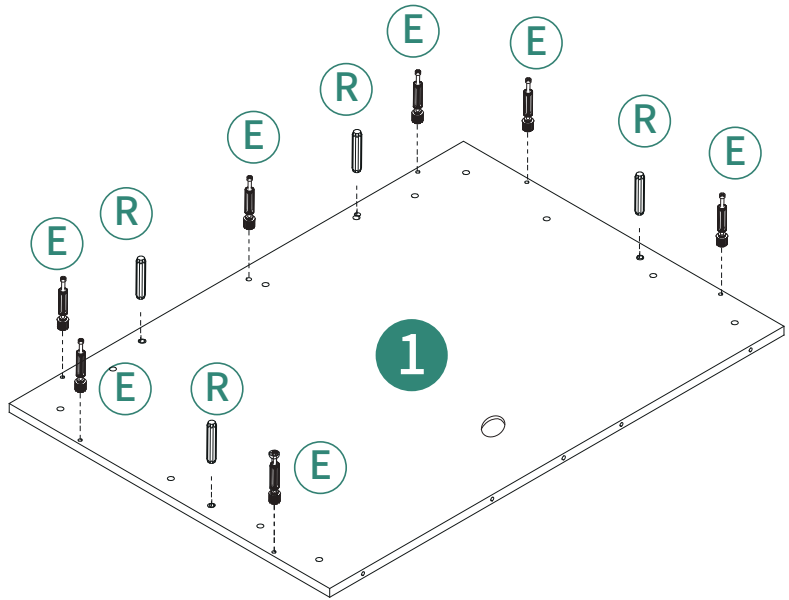
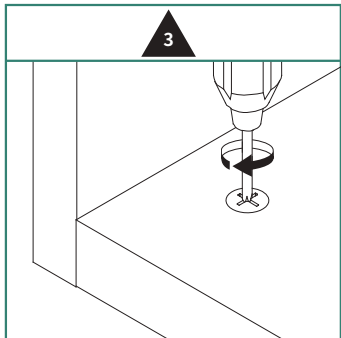
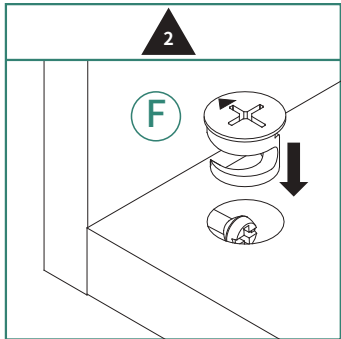
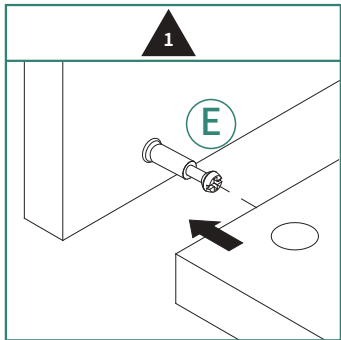
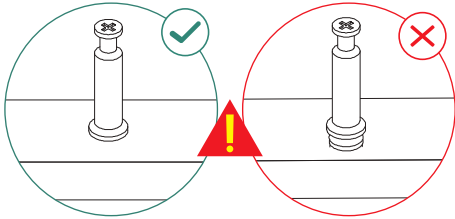

6

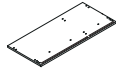

④1pc



ⓔ6pcs



Ⓡ8pcs



ⓖ7pcs

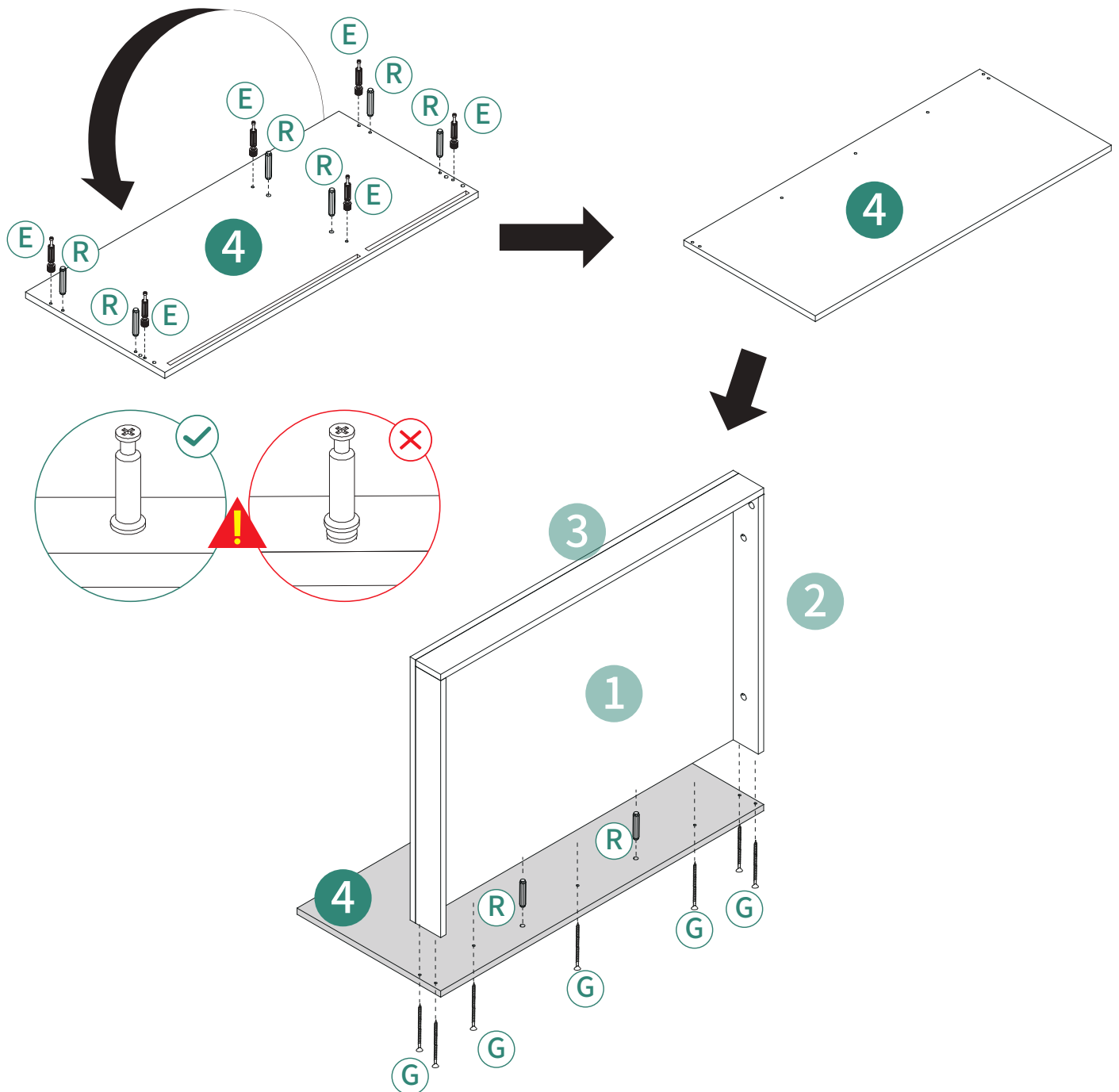

7 
ⓕ6pcs

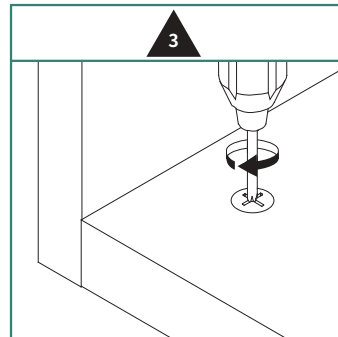
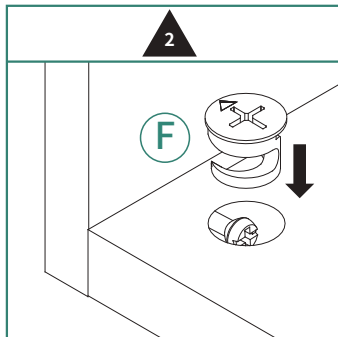
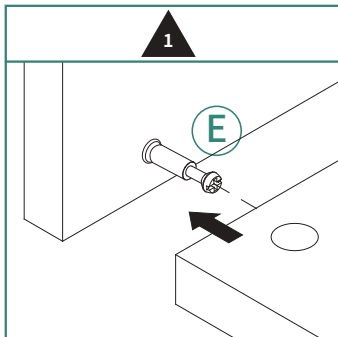
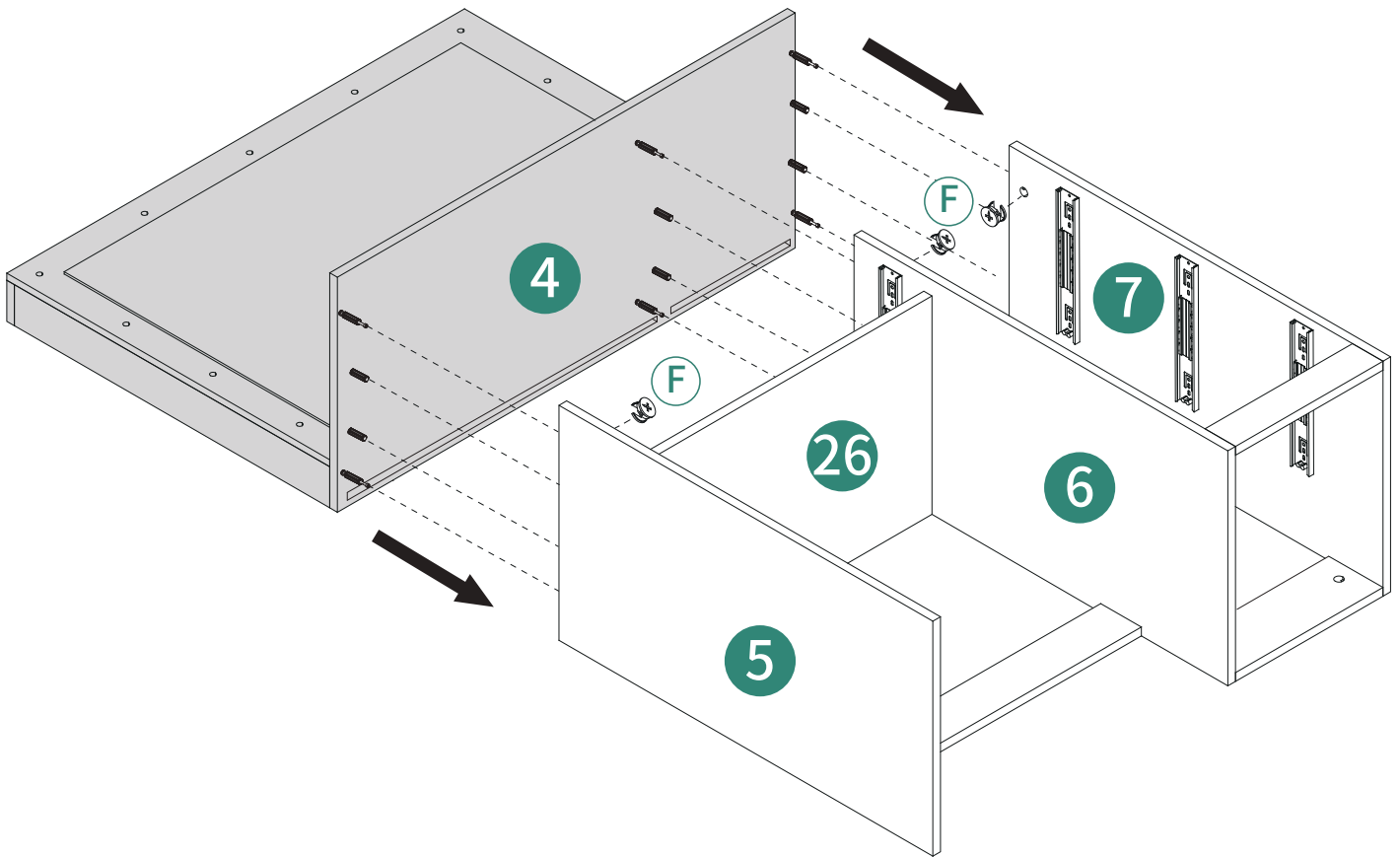

8



Ⓜ1pc



Ⓝ1pc



ⓓ4pcs

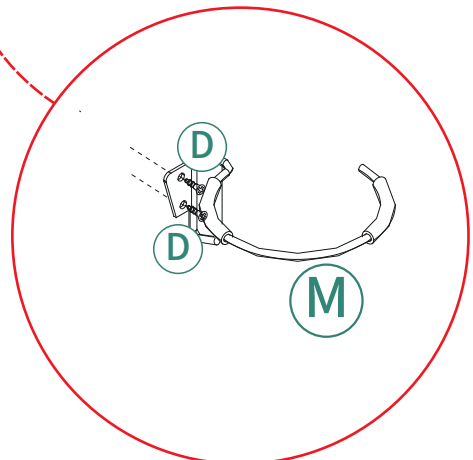
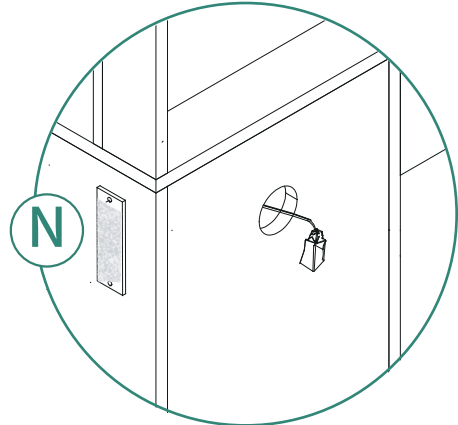
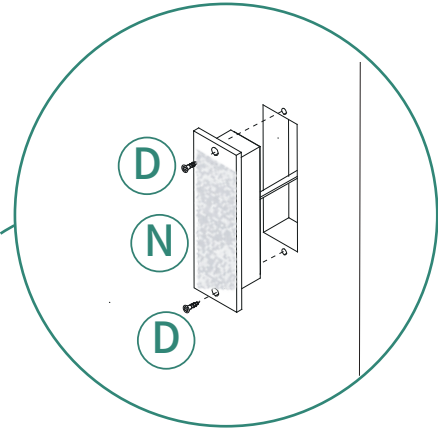
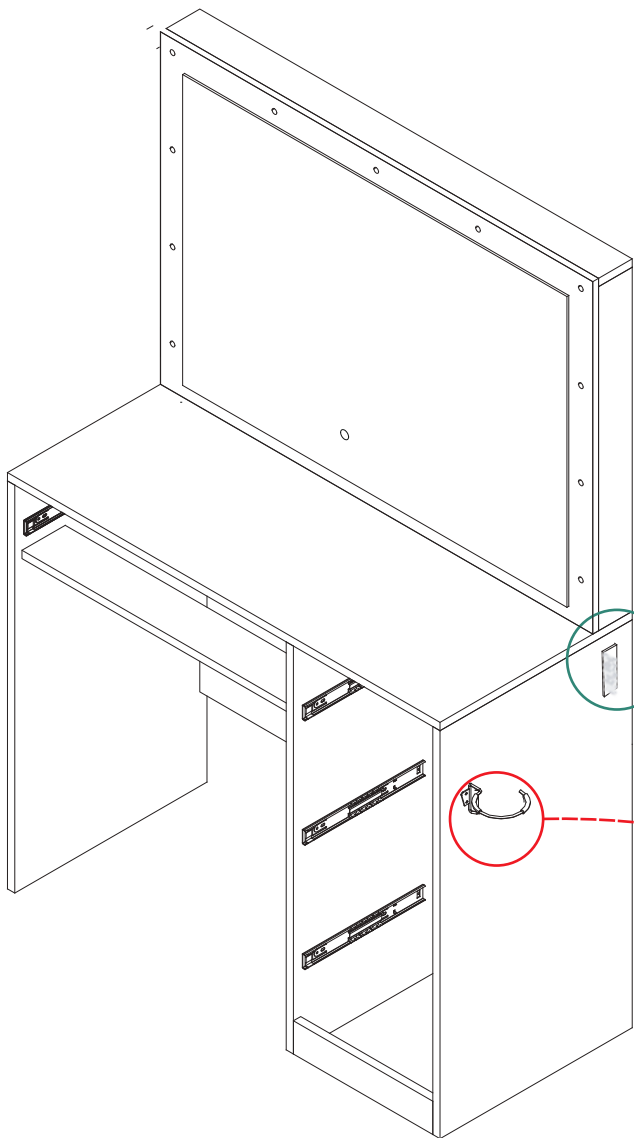

Install at a location based on your needs.
Installieren Sie an einem Ort , der Ihren Bedürfnissen entspricht.
Installez à l'emplacement qui convient le mieux à vos besoins.
Installare in una posizione in base alle tue esigenze.
Instalar en una ubicación según sus necesidades.

9

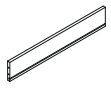

⑰1pc

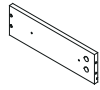

⑱1pc

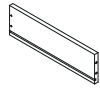

⑲1pc

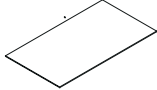

⑳1pc



Ⓒ4pcs



Ⓐ4pcs

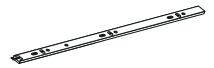

Ⓘ12pcs

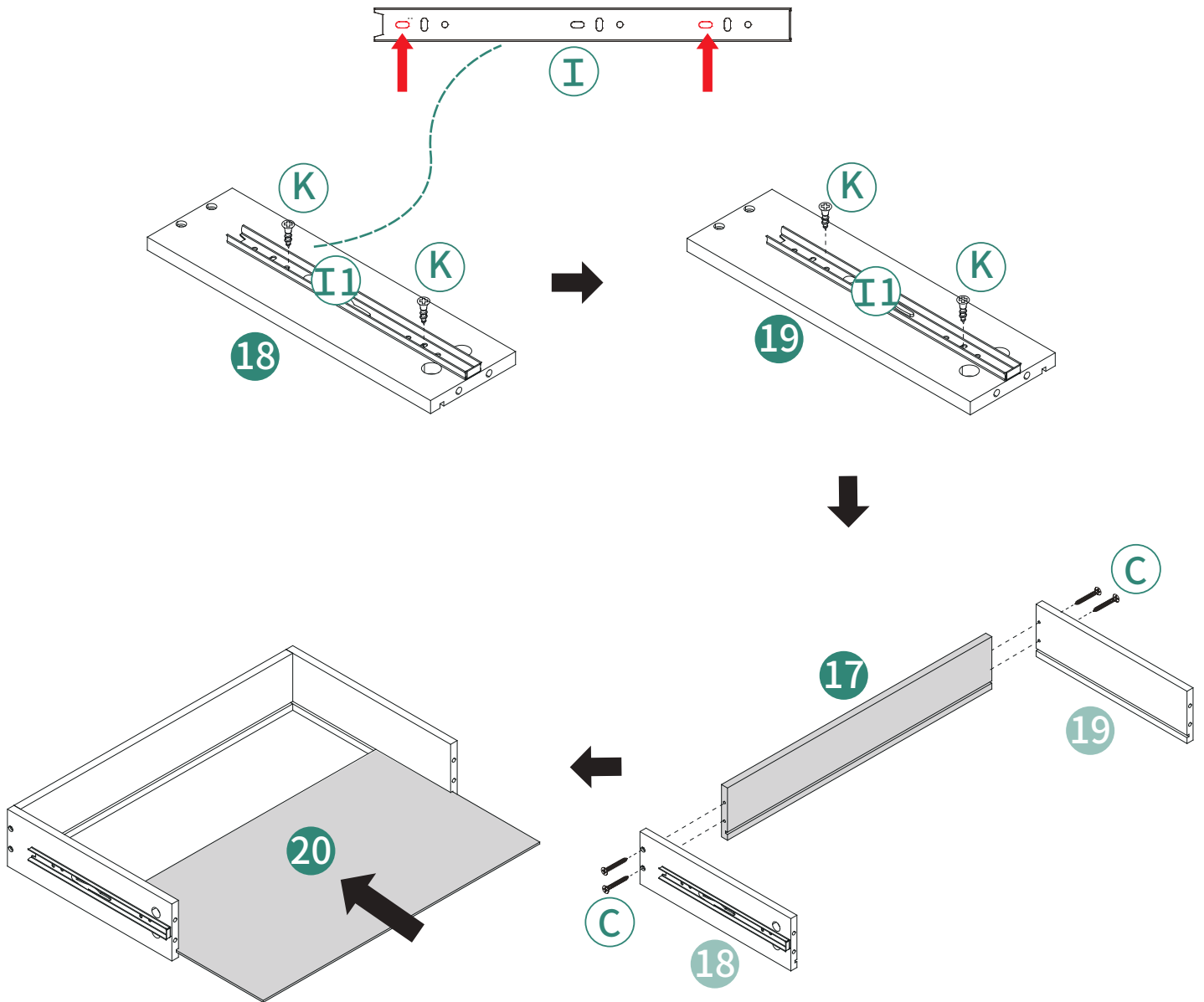

10

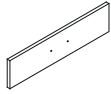

21 1pc



A 2pcs



E 4pcs



F 4pcs



H 1pc

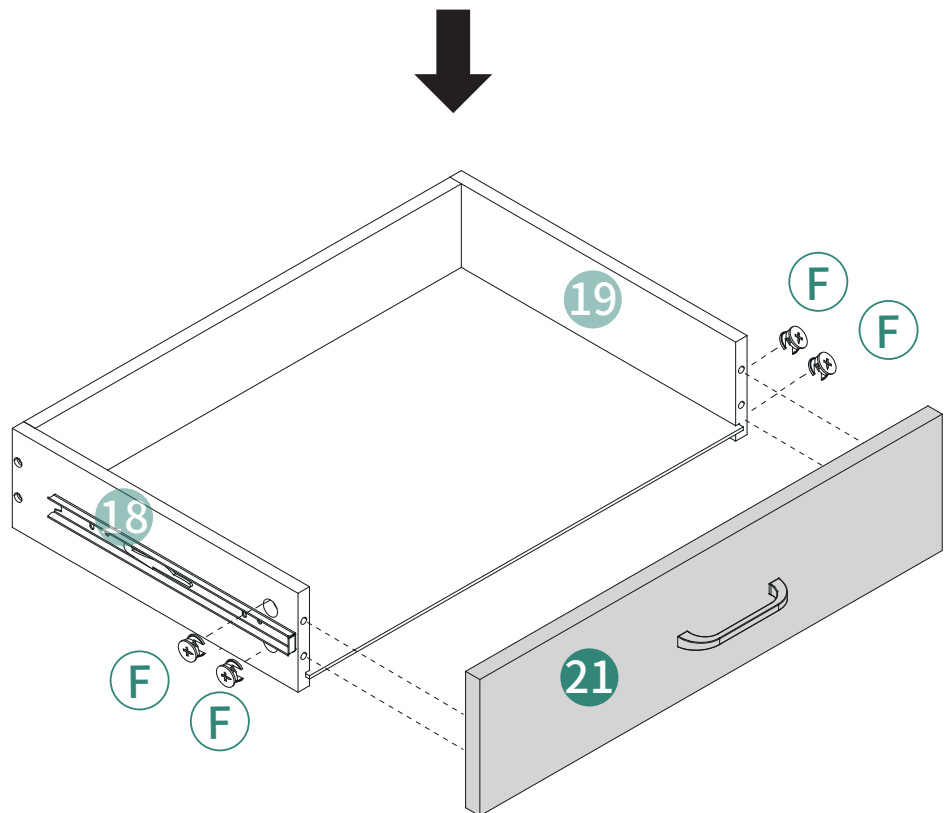
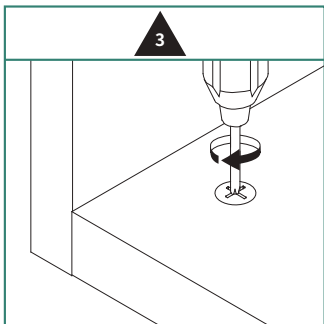
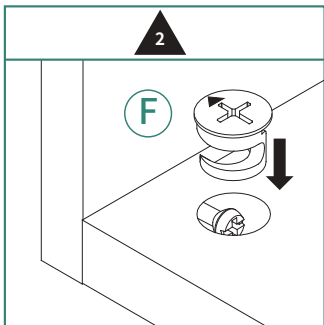
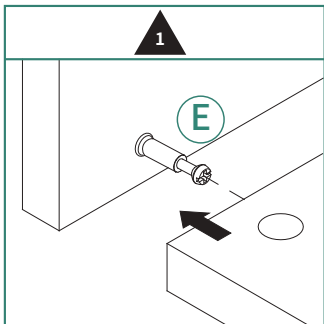
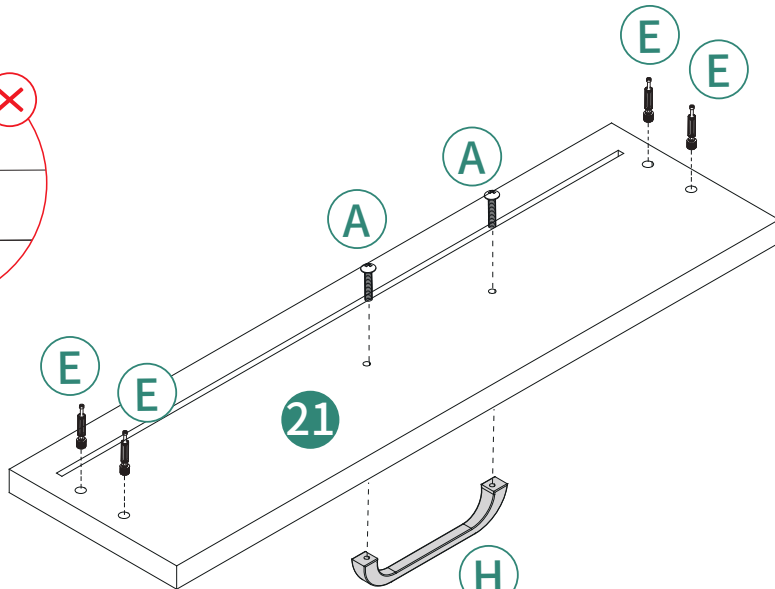
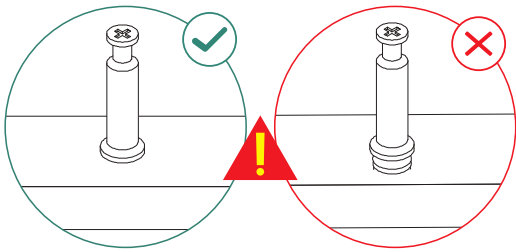

11

X3

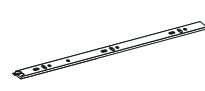
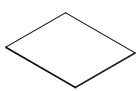

⑬ 3pcs

⑭ 3pcs

⑮ 3pcs

⑫ 3pcs

Ⓒ 12pcs

Ⓐ 12pcs

Ⓘ 6pcs

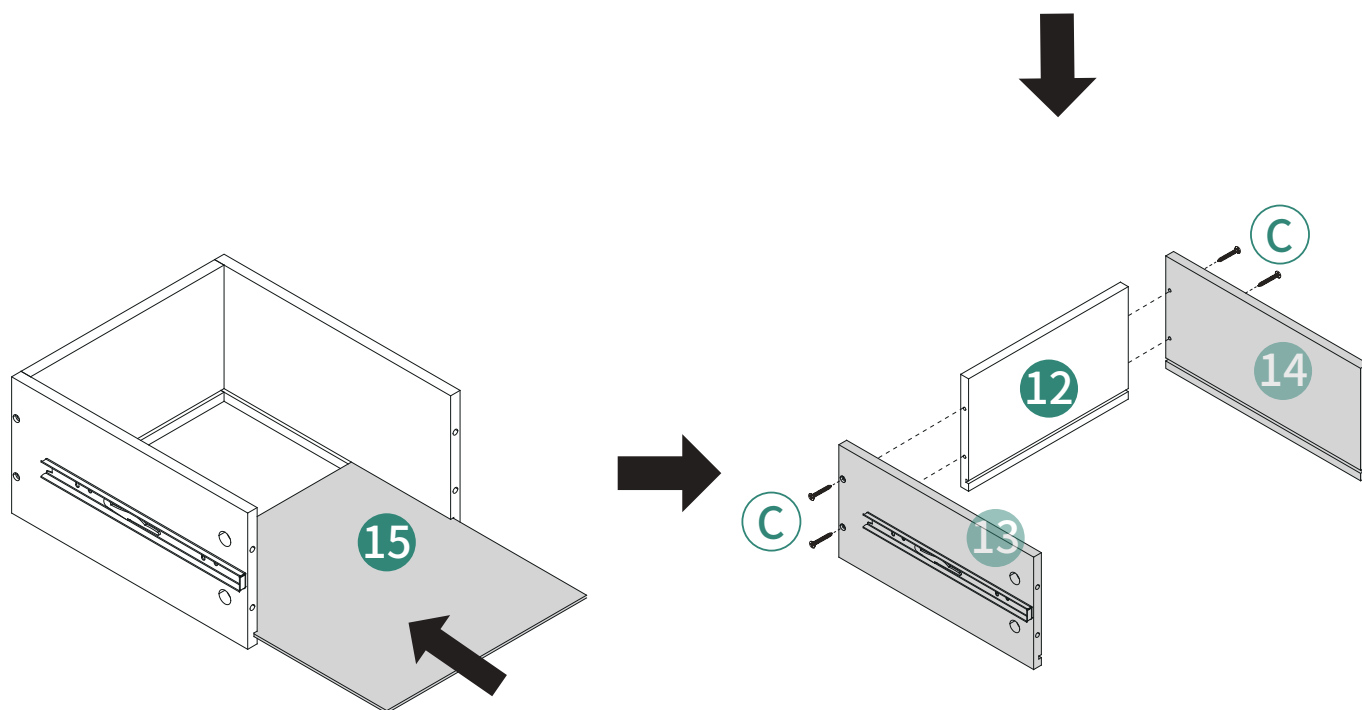
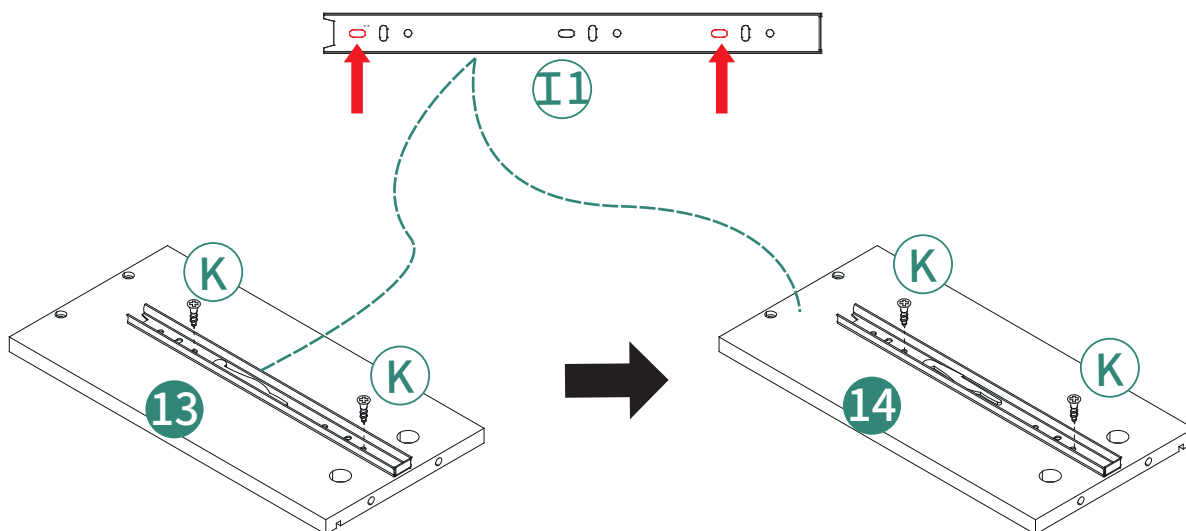

12
X3

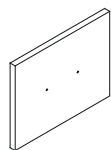

16 3pcs



A 6pcs



E 12pcs



F 12pcs



H 3pcs

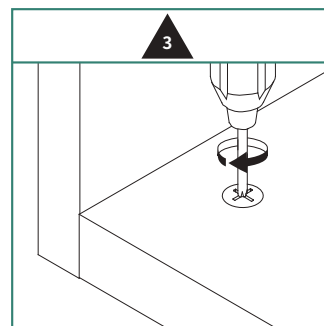
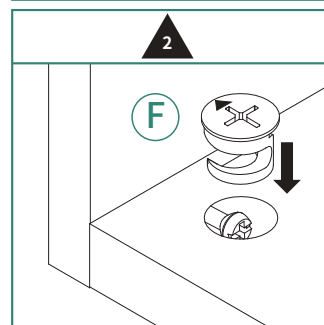
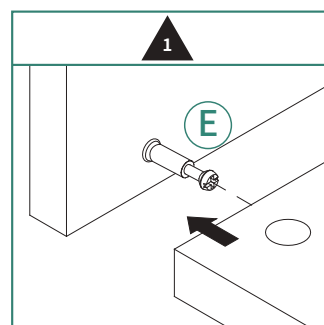
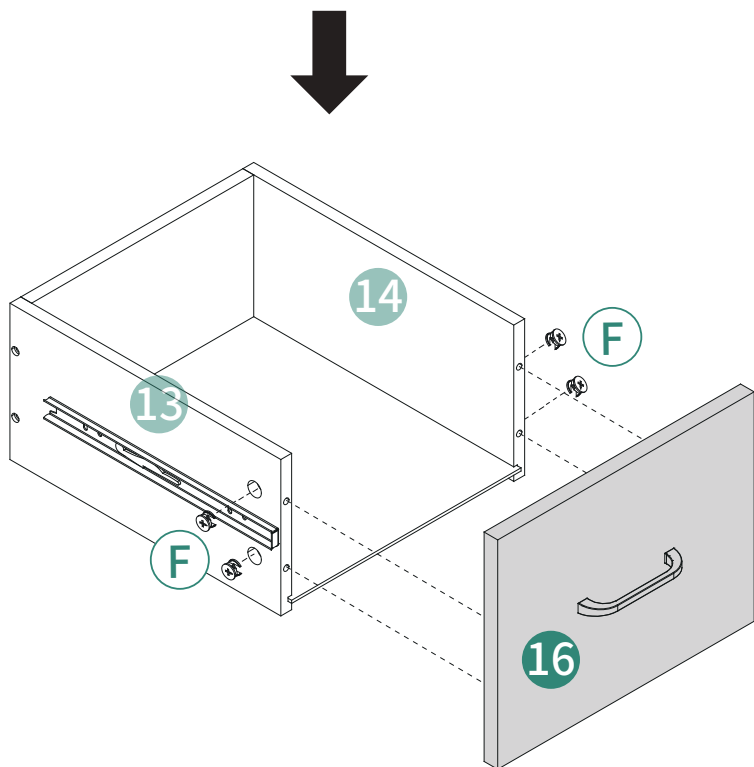
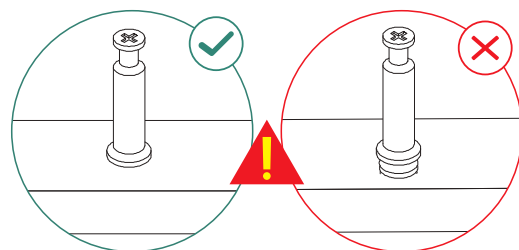
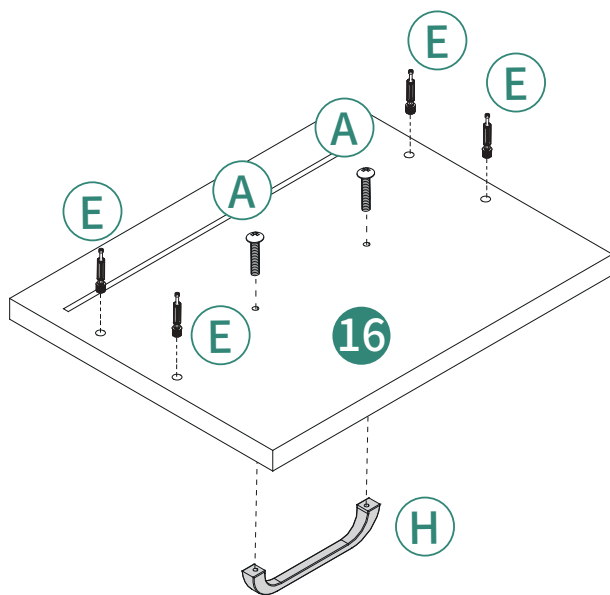

13

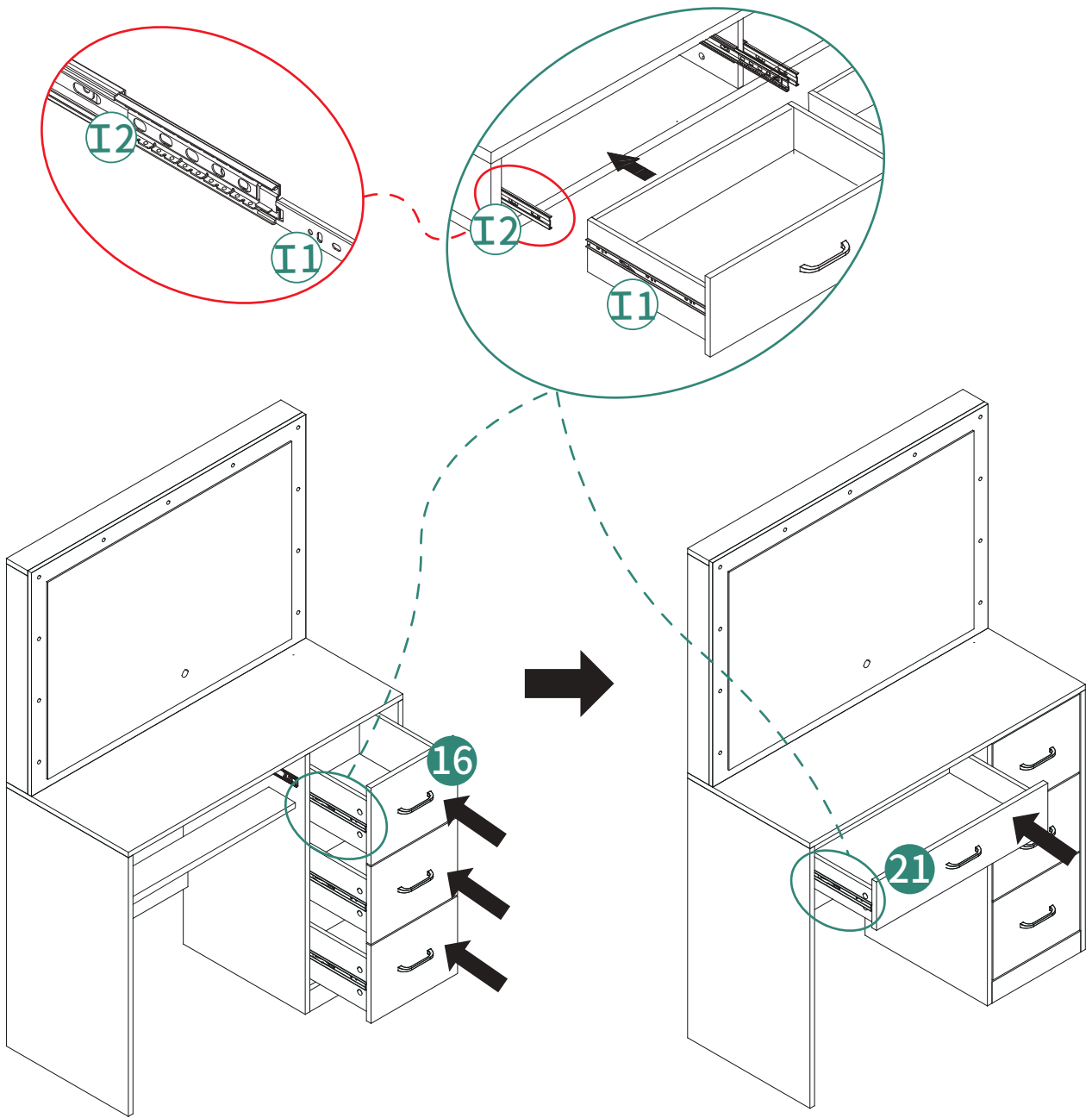

14

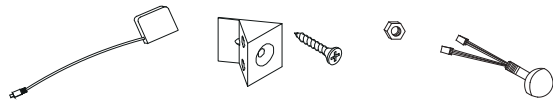

Ⓟ 1pc

Ⓢ 8pcs

Ⓣ 11pcs

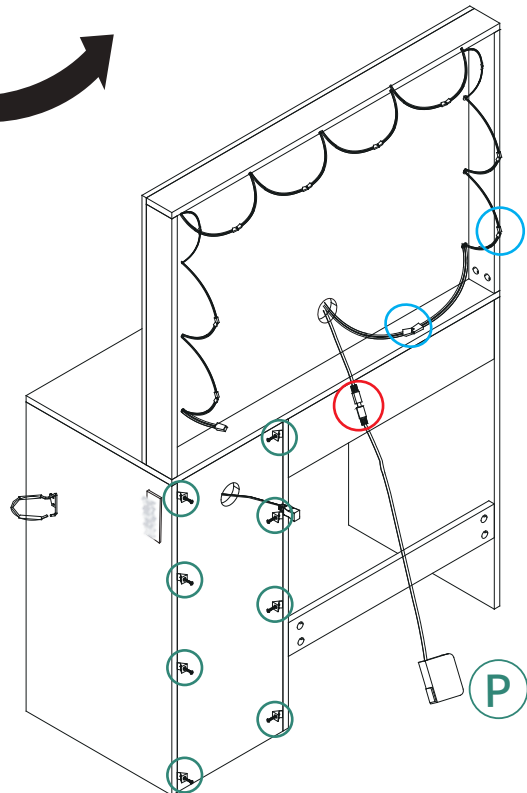
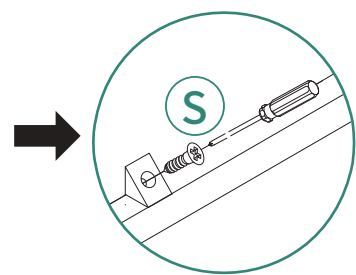
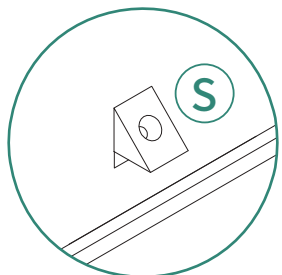
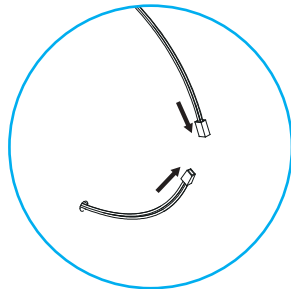
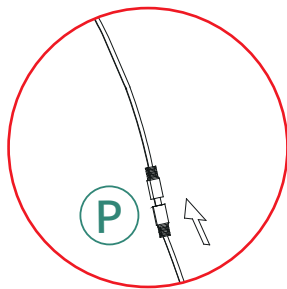
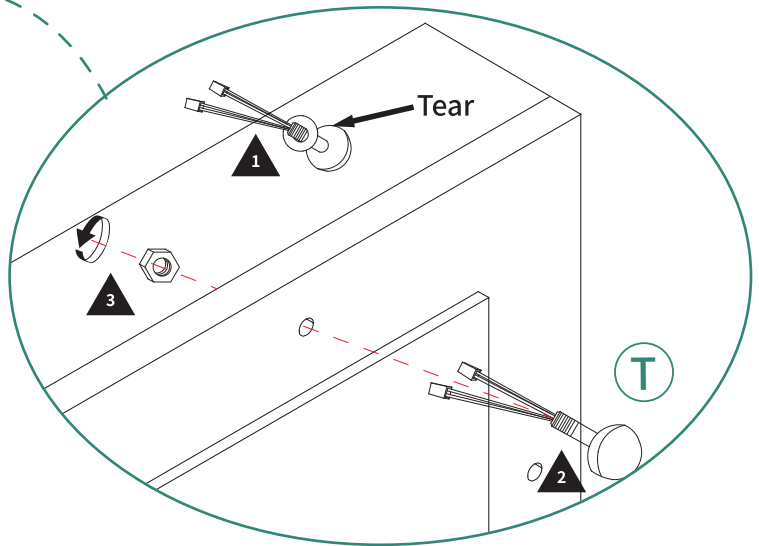
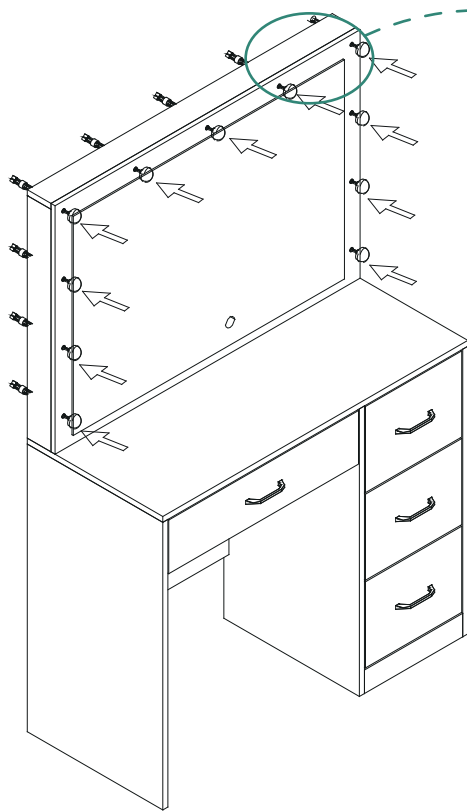

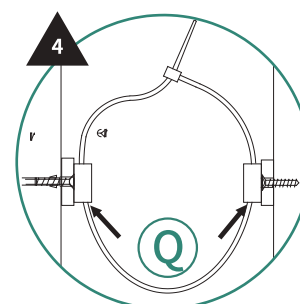
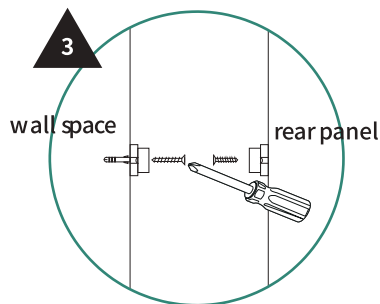
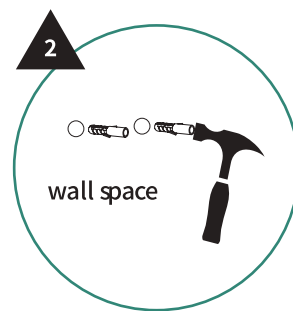
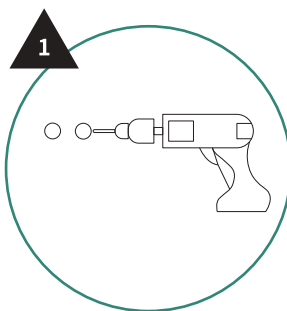
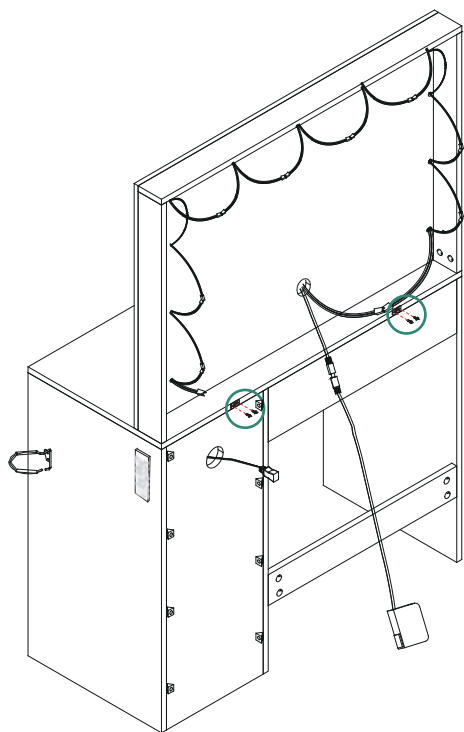

!
 After the cabinet assembly , please install the wall fixing device on the back of the cabinet to avoid accidents.
 Install at a location based on your needs.

Nach dem Zusammenbau des Schrankes installieren Sie bitte die Wandbefestigungsvorrichtung auf der Rückseite des Schrankes , um Unfälle zu vermeiden.
 Installieren Sie an einem Ort , der Ihren Bedürfnissen entspricht.

Après l'assemblage de l'armoire , veuillez installer le dispositif de fixation murale à l'arrière de l'armoire pour éviter les accidents.
 Installez à l'emplacement qui convient le mieux à vos besoins.

Dopo il montaggio del mobile , installare il dispositivo di fissaggio a parete sul retro del mobile per evitare incidenti.
 Installare in una posizione in base alle tue esigenze.

Después del ensamblaje del armario , por favor instale el dispositivo de fijación de pared en la parte posterior del armario para evitar accidentes.
 Instalar en una ubicación según sus necesidades.

16

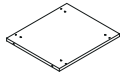

23 1pc



24 2pcs



25 2pcs



E 16pcs



F 4pcs

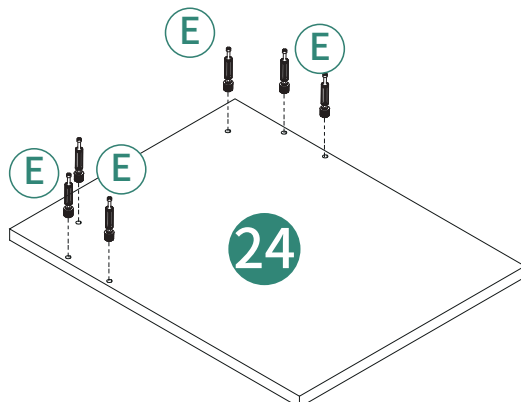
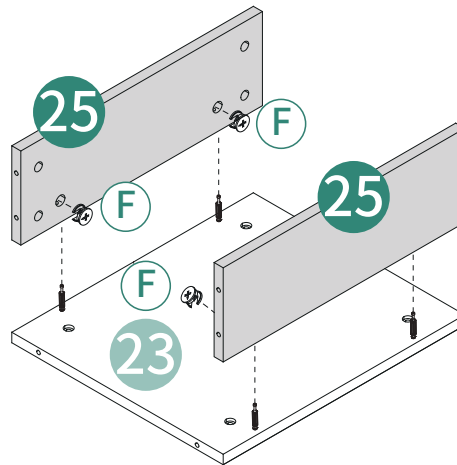
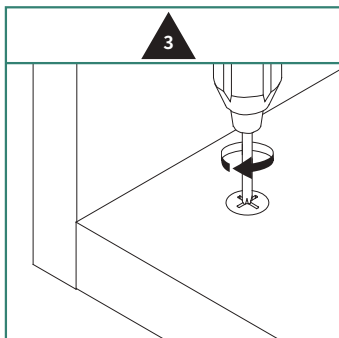
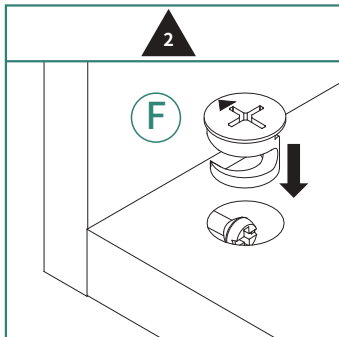
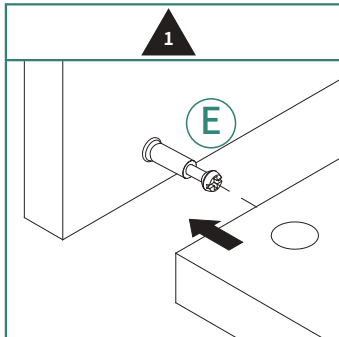
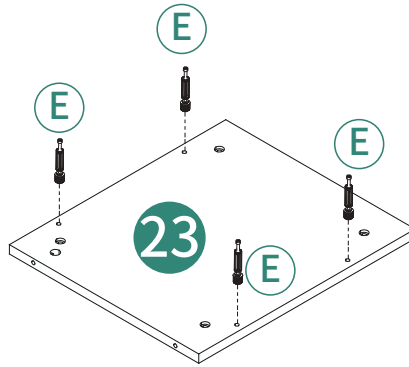
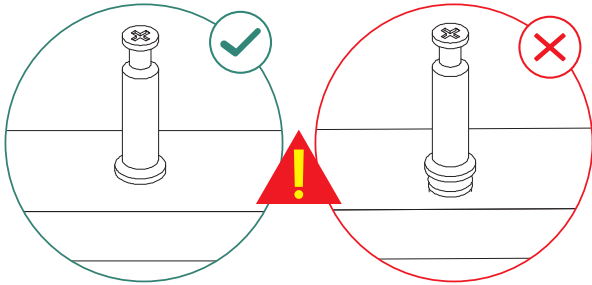

17

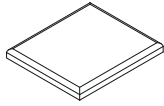

22 1pc



B 4pcs



F 12pcs

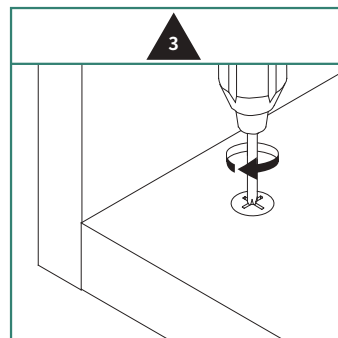
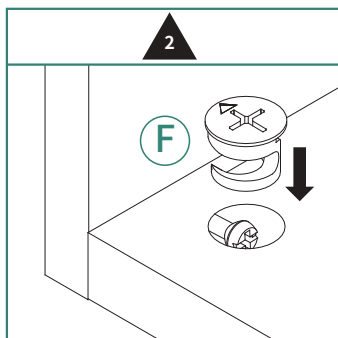
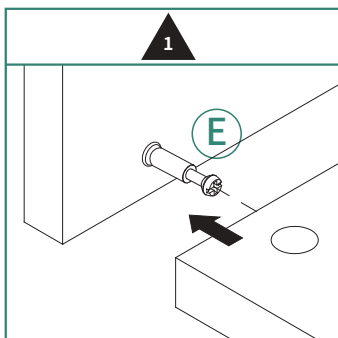
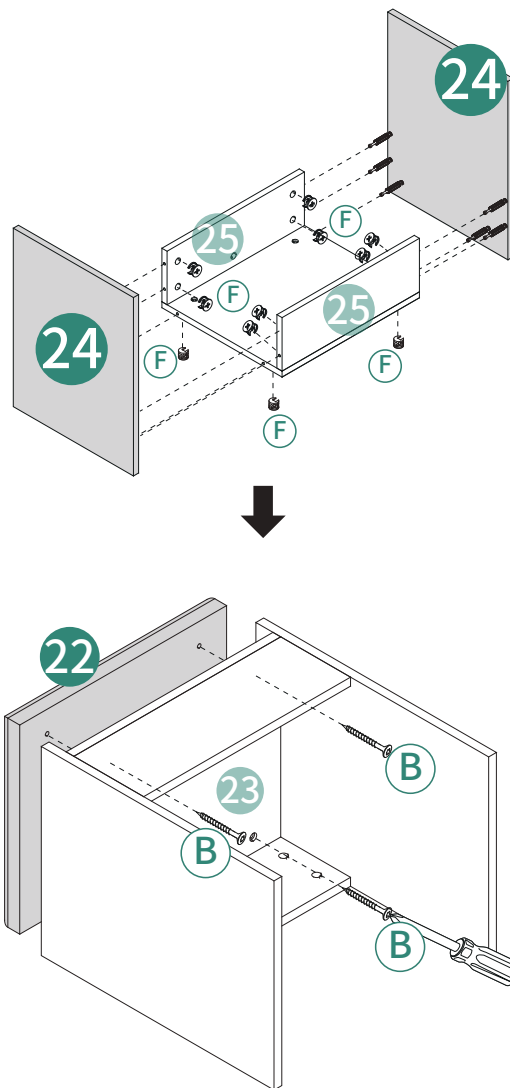

18

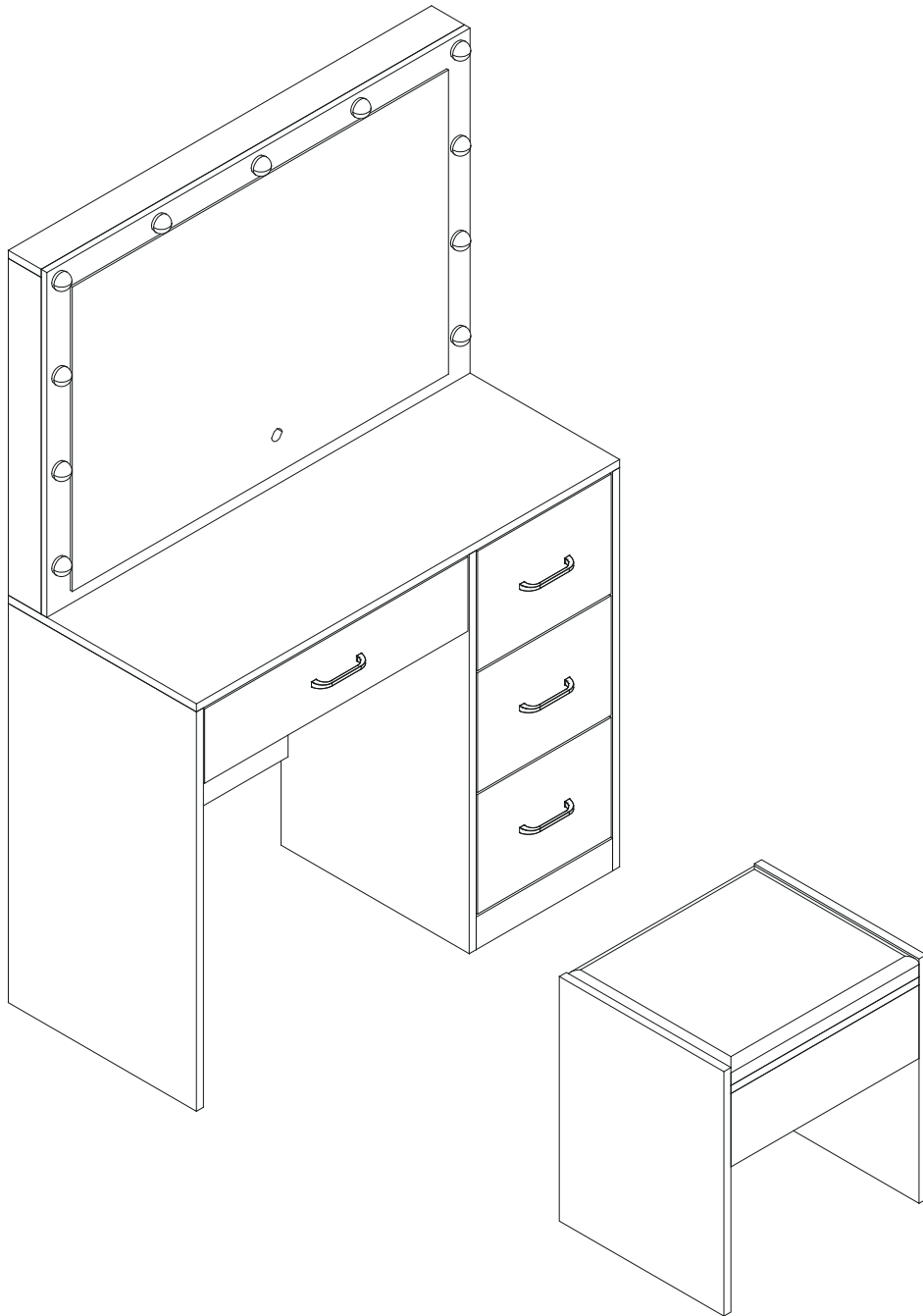

Installation Completed

Installation Abgeschlossen

Installation Complétée

Installazione Completata

Instalación Completada

HELP CENTER



Inquiry



Assembly issue



Missing parts

If you encounter any difficulties during assembly, please contact us.

Wenn Sie während der Montage auf Schwierigkeiten stoßen, kontaktieren Sie uns bitte.

Si vous rencontrez des difficultés lors du montage, veuillez nous contacter.

Se incontri difficoltà durante il montaggio, ti preghiamo di contattarci.

Si encuentras alguna dificultad durante el ensamblaje, por favor contáctanos.

DISCLAIMER

Manufacturer and seller expressly disclaim any and all liability for personal injury, property damage or loss, whether direct, indirect, or incidental, resulting from the incorrect attachment, improper use, inadequate maintenance, unapproved modification, or neglect of this product.

Der Hersteller und Verkäufer lehnen ausdrücklich jegliche Haftung für Personenschäden, Sachschäden oder Verluste ab, egal ob direkt, indirekt oder zufällig, die durch falsche Anbringung, unsachgemäßen Gebrauch, unzureichende Wartung, nicht genehmigte Änderungen oder Vernachlässigung dieses Produkts entstehen.

El fabricante y vendedor renuncian expresamente a toda responsabilidad por lesiones personales, daños materiales o pérdidas, ya sean directos, indirectos o incidentales, derivados de la incorrecta colocación, uso inadecuado, mantenimiento insuficiente, modificación no aprobada o negligencia de este producto.

Il produttore e il venditore declinano espressamente ogni responsabilità per lesioni personali, danni materiali o perdite, dirette, indirette o incidentali, derivanti dall'errato fissaggio, uso improprio, manutenzione inadeguata, modifica non autorizzata o negligenza di questo prodotto.

Le fabricant et le vendeur déclinent expressément toute responsabilité en cas de blessures corporelles, de dommages matériels ou de pertes, qu'ils soient directs, indirects ou accessoires, résultant de la fixation incorrecte, de l'utilisation inappropriée, de l'entretien insuffisant, de la modification non approuvée ou de la négligence de ce produit.