

LIFT TOP COFFEE TABLE

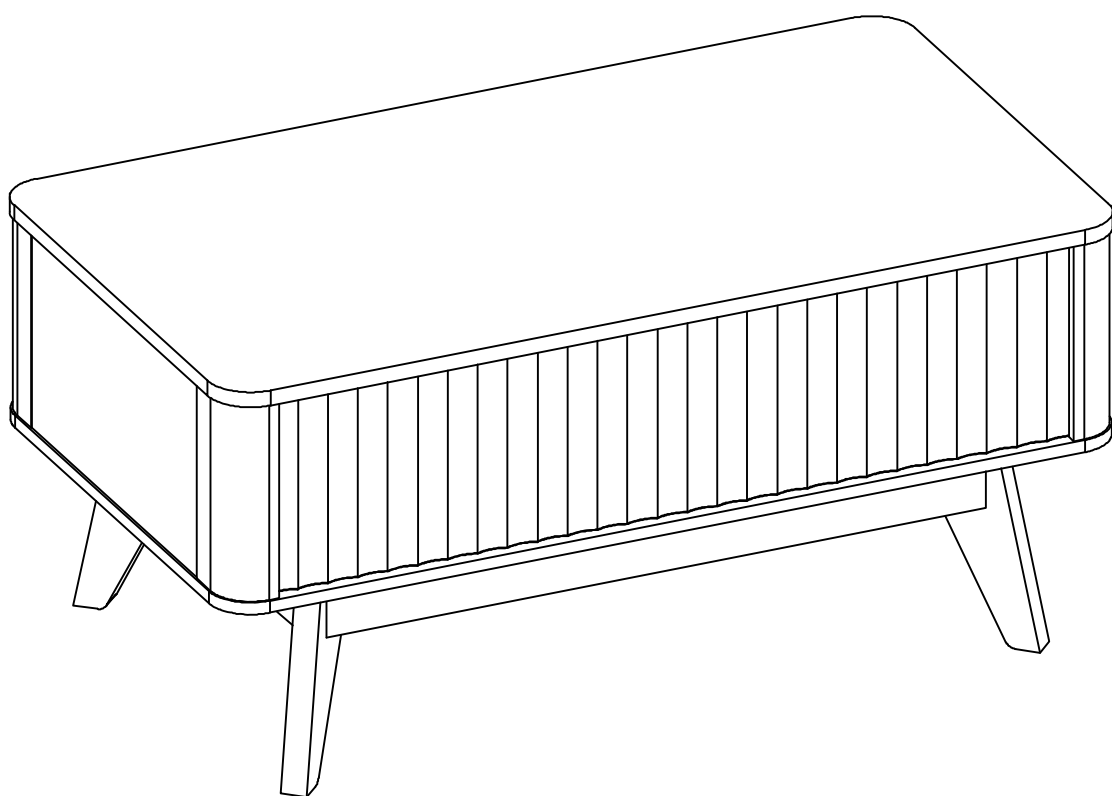

ASSEMBLY INSTRUCTIONS

Before you start...

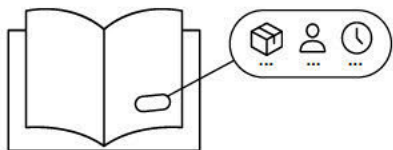

Ensure you have received all cartons and familiarize yourself with the workload. Make sure there are enough helping hands to assist you, and that you have allocated the time required to assemble your new product.

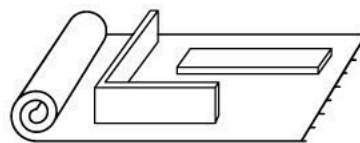

Make sure you have cleared enough space in your home for the assembly. We recommend protecting your floor with a mat or cardboard to avoid scratches during the assembly process.

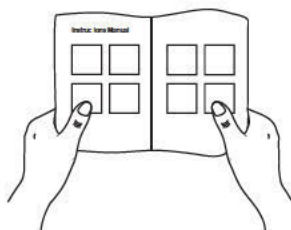

Read instructions carefully and check no parts are missing.

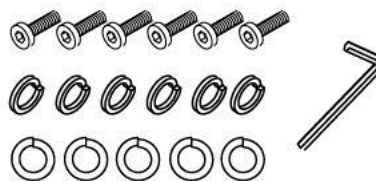

Lay out all hardware on a soft surface so you can easily identify them.

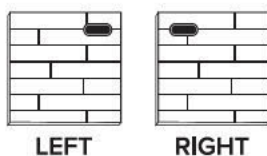

Carefully identify all components in order to differentiate which pieces are left and right.

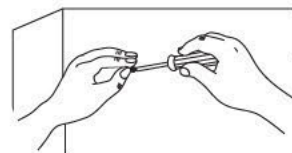

Install your new product carefully following the instructions. Don't skip ahead!

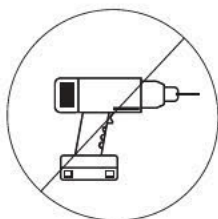

DO NOT over tighten screws or use a drill. It will damage the product.









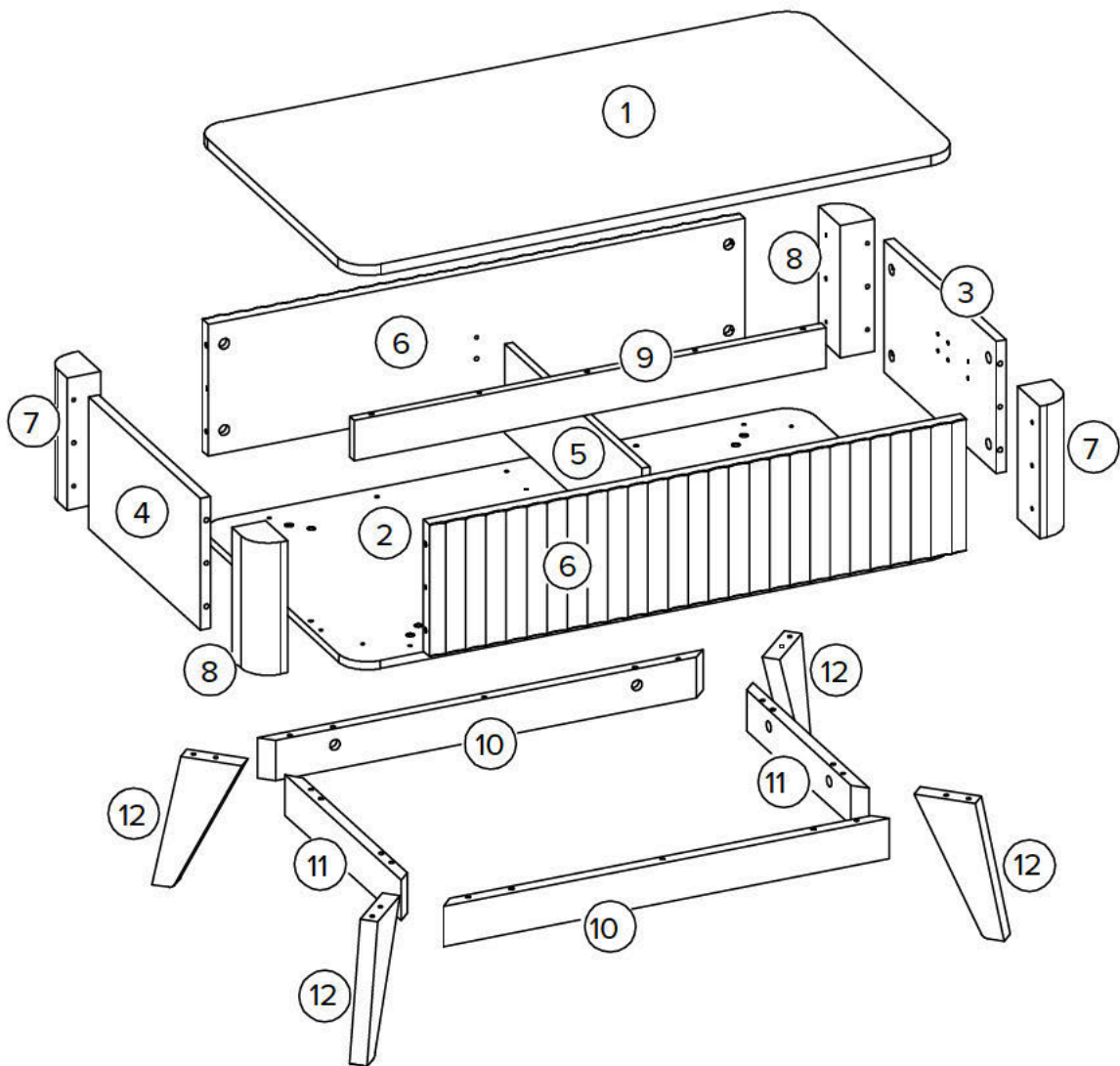





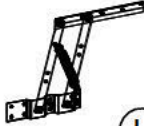

If you need further assistance with assembling your Mopio product, please chat with us





Parts

- | | | |
|-------------------------------|-------------------------------|-------------------------------|
| <input type="checkbox"/> ① x1 | <input type="checkbox"/> ⑤ x1 | <input type="checkbox"/> ⑨ x1 |
| <input type="checkbox"/> ② x1 | <input type="checkbox"/> ⑥ x2 | <input type="checkbox"/> ⑩ x2 |
| <input type="checkbox"/> ③ x1 | <input type="checkbox"/> ⑦ x2 | <input type="checkbox"/> ⑪ x2 |
| <input type="checkbox"/> ④ x1 | <input type="checkbox"/> ⑧ x2 | <input type="checkbox"/> ⑫ x4 |





Hardware

<input type="checkbox"/>		Cambolt Ø 6 x 35 mm	<input type="checkbox"/>		Screw Ø 6 x 52 mm	<input type="checkbox"/>		Metal Support
	(A)	x29		(F)	x16		(K)	x1
<input type="checkbox"/>		Camlock Ø 15 mm	<input type="checkbox"/>		Varianta Screw	<input type="checkbox"/>		Elevating table (R)
	(B)	x29		(G)	x12		(L)	x1
<input type="checkbox"/>		Sticker Ø 25 mm	<input type="checkbox"/>		Bolt M6 x 10 mm	<input type="checkbox"/>		Elevating table (L)
	(C)	x29		(H)	x8		(L)	x1
<input type="checkbox"/>		Dowel Ø 6 x 30 mm	<input type="checkbox"/>		Washer	<input type="checkbox"/>		Bolt M6 x 15 mm
	(D)	x32		(I)	x8		(M)	x4
<input type="checkbox"/>		Assembly screw	<input type="checkbox"/>		Washer	<input type="checkbox"/>		Nut
	(E)	x8		(J)	x4		(N)	x4

-  There are inner box(es) that include components required to complete this assembly.
-  Please do not completely tighten all the hardware, until the entire assembly is complete.
-  Before discarding the packaging, please use the checklist to ensure that you have all the parts required to assemble your product. Please kindly note you will need the original package if you want to return the product later.
-  If parts are missing or damaged, we will gladly ship your replacements parts free of charge. Please contact us at help@mopio.com or chat with us

x1

x2

45 mins

Step 1

Ensure your floor is properly protected, then take out 2 pieces of panel (6), and panel (5).

Screw Cambolt (A) to panel (6) (don't over screw).

Plug in Dowel (D) into the holes on the 2 pieces of panel (6), and panel (5).

*Don't screw too deep

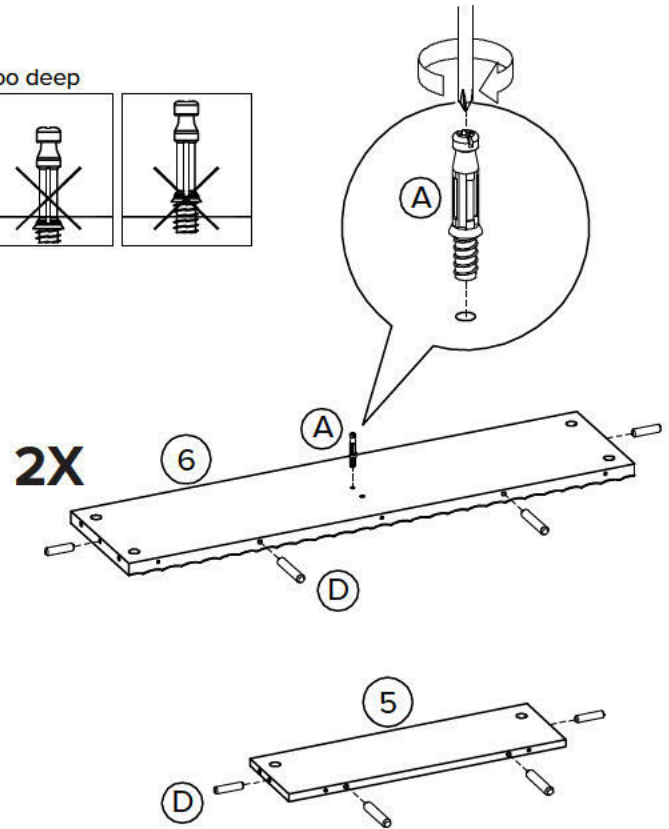
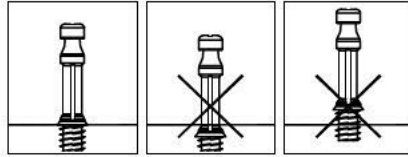

Step 2

Install panel (5) onto 2 pieces of panel (6) by inserting camlock (B) and tightening it with a screw driver.

Please ensure the correct camlock placing orientation. Check the illustration carefully.

Place Sticker Cam (C) over the Connecting Cams (B).

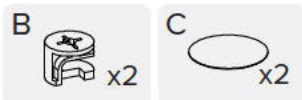
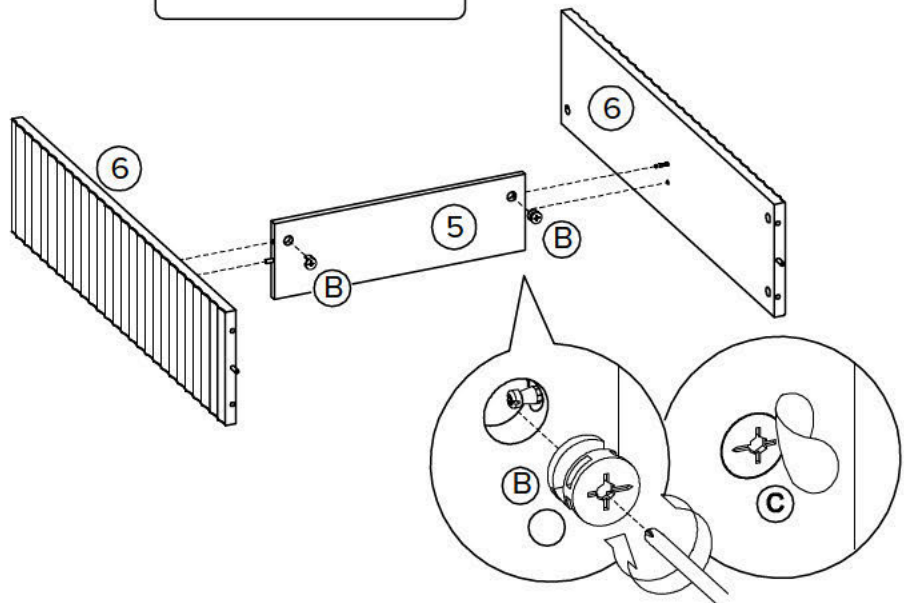
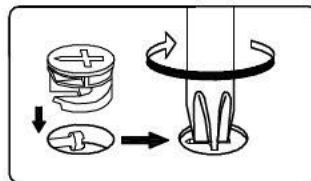

Step 3

Screw Cambolt (A) to 2 pieces of panel (7) and 2 pieces of panel (8) (don't over screw).

Plug in Dowel (D) into the holes on panel (3) and (4).

*Don't screw too deep

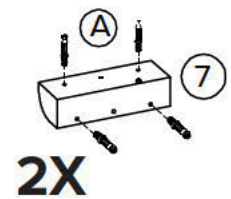
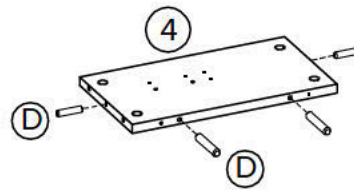
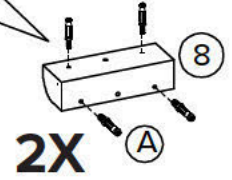
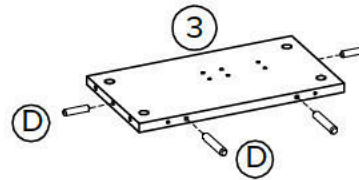
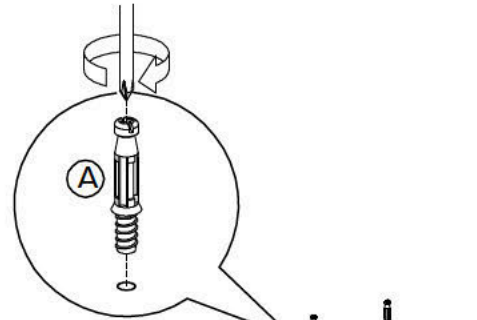
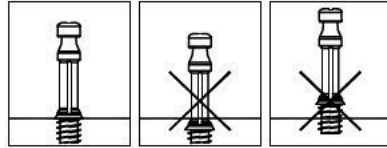

Step 4

Install panels (7) and (8) onto panel (4) by inserting camlock (B) and tightening it with a screw driver.

Please ensure the correct camlock placing orientation. Check the illustration carefully.

Place Sticker Cam (C) over the Connecting Cams (B).

Install panels (7) and (8) onto panel (3) by inserting camlock (B) and tightening it with a screw driver.

Please ensure the correct camlock placing orientation. Check the illustration carefully.

Place Sticker Cam (C) over the Connecting Cams (B).

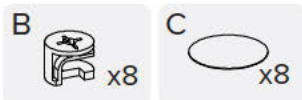
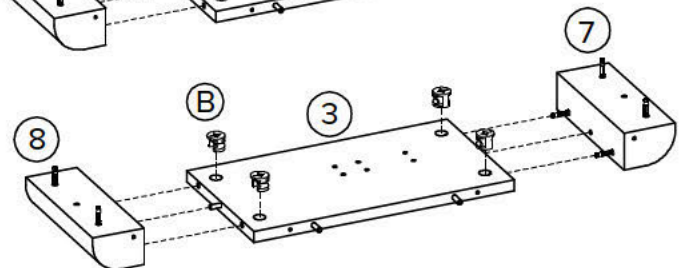
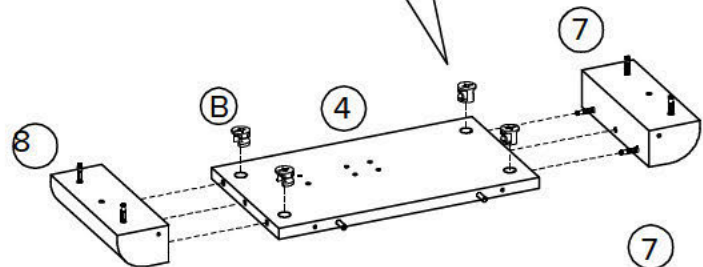
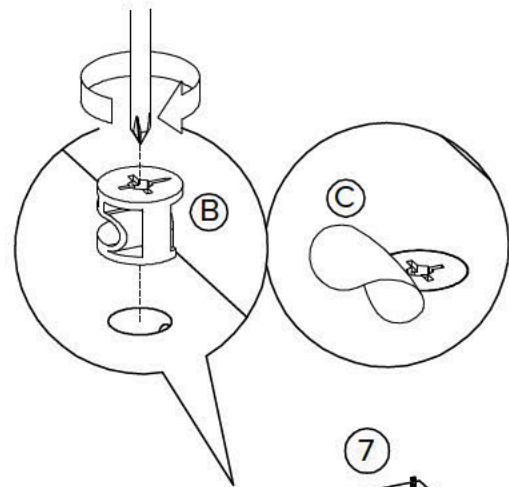
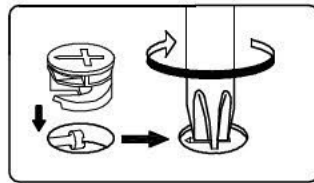

Step 5

Fasten Right Elevating table (L) onto Panel (3) with Varianta screw (G).

Ensure you are using elevating table (L) - R

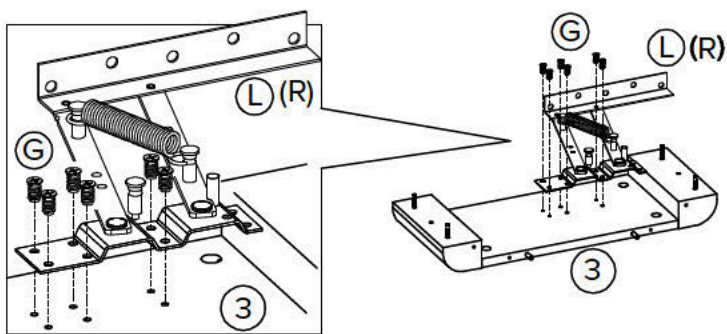

Fasten Left Elevating table (L) onto Panel (4) with Varianta screw (G).

Ensure you are using elevating table (L) - L

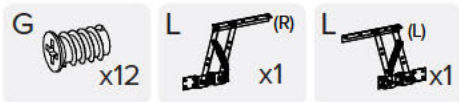
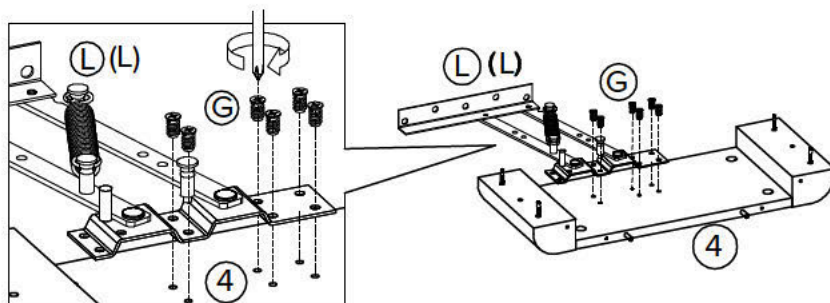

Step 6

Install panels (3) and (4) onto 2 pieces of panel (6) by inserting camlock (B) and tightening it with a screw driver.

Please ensure the correct camlock placing orientation. Check the illustration carefully.

Place Sticker Cam (C) over the Connecting Cams (B).

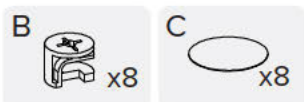
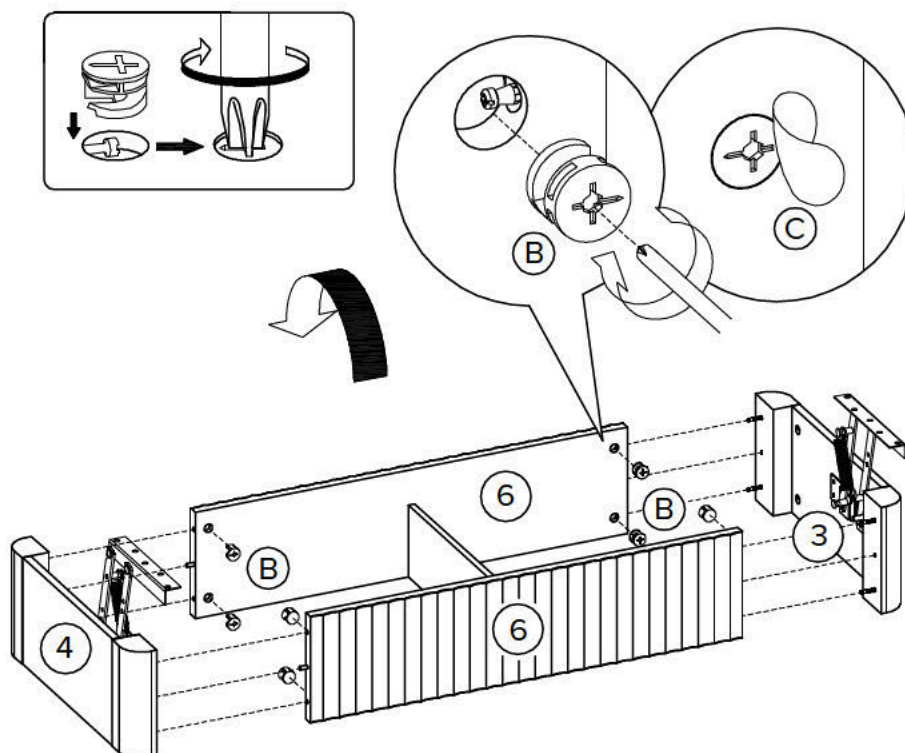

Step 7

Screw Cambolt (A) to panel (2) (don't over screw).

Plug in Dowel (D) into the holes on 2 pieces of panel (10) and 2 pieces of panel (11).

*Don't screw too deep

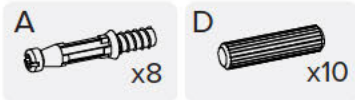
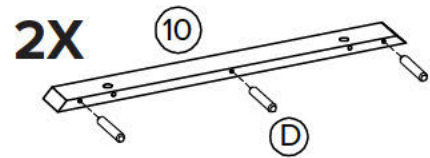
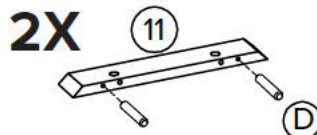
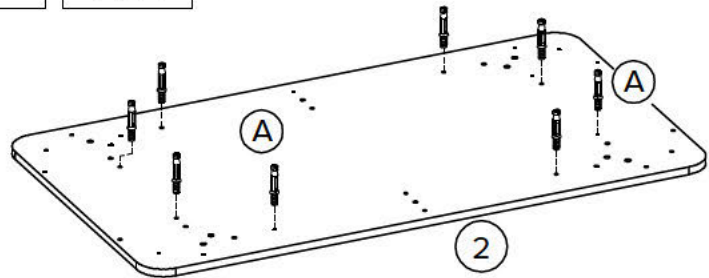
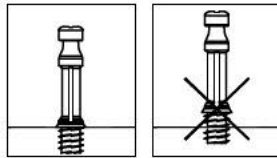

Step 8

Position and install Leg (12) into panel (2) by inserting assembly screw (E) and tightening it with a screw driver.

Place Sticker Cam (C) over the Assembly screw (E).

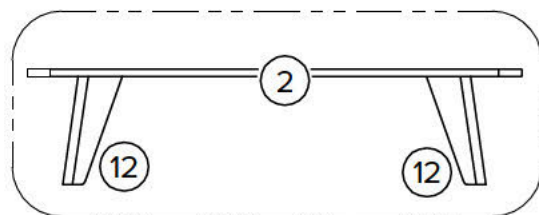
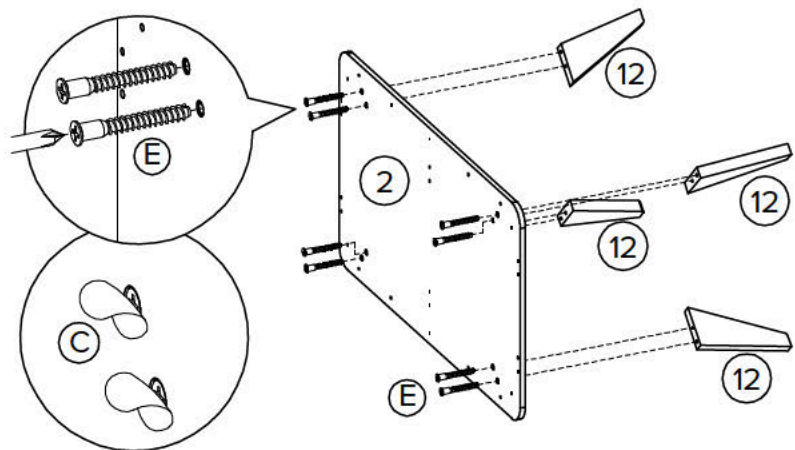

Step 9

Orientate and lay the assembled unit on the side so that both Left and Right Elevating table do not touch the ground.

Position and install panel (2) into assembled unit by inserting screw (F) and tightening it with a screw driver.

Please ensure you screw or plug into the correct holes according to the illustrations.

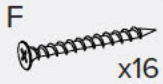
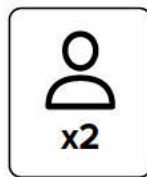
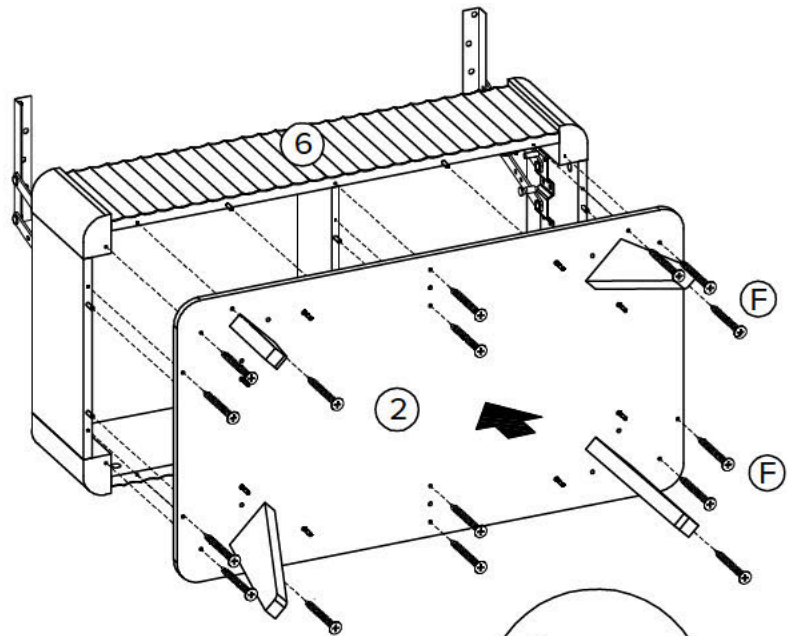

Step 10

Position and install 2 pieces of panel (10) and 2 pieces of panel (11) by inserting camlock (B) and tightening it with a screw driver.

Please ensure the correct orientation for panel (10) and panel (11), and camlock placing orientation. Check the illustration carefully.

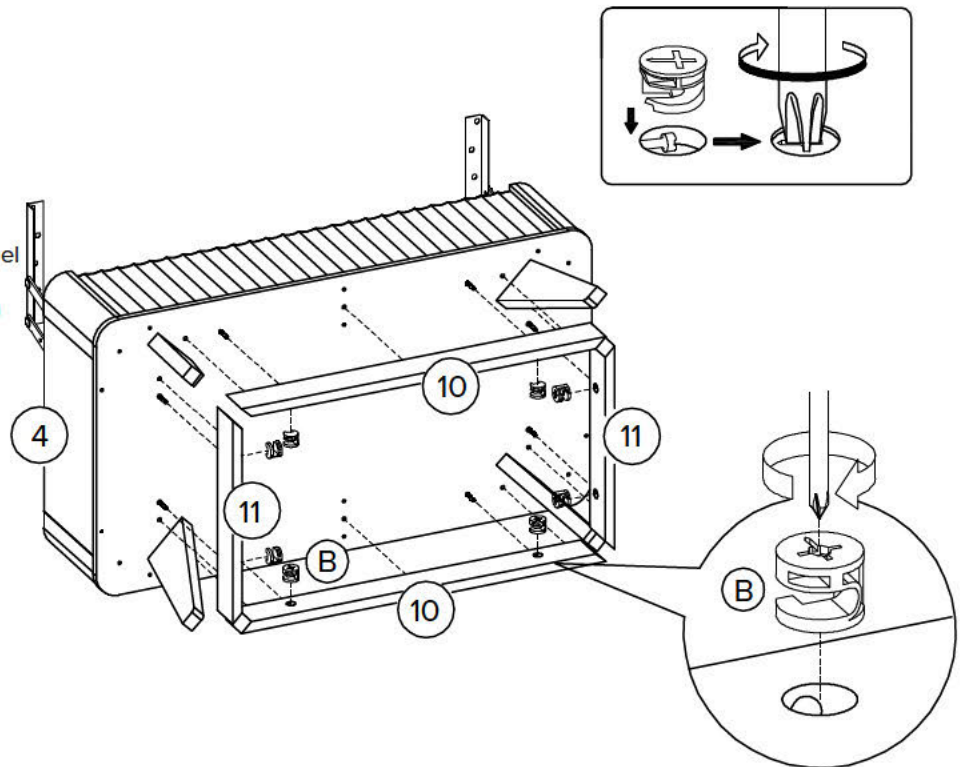

Step 11

Screw Cambolt (A) to panel (1) (don't over screw).

Plug in Dowel (D) into the holes on (9).

*Don't screw too deep

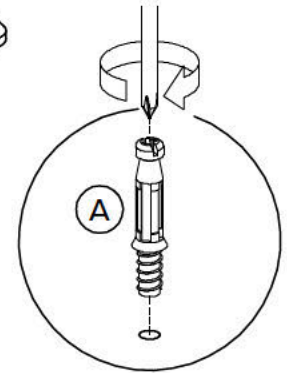
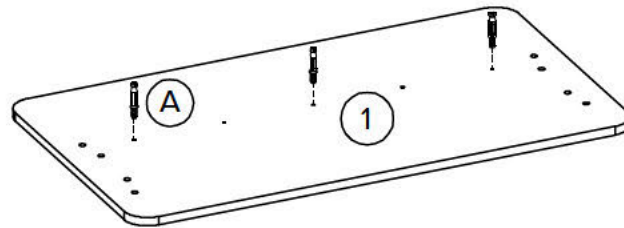
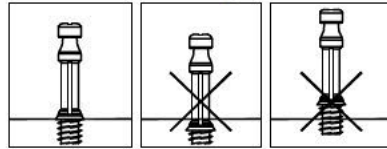

Step 12

Install panel (9) onto panel (1) by inserting camlock (B) and tightening it with a screw driver.

Please ensure the correct camlock placing orientation. Check the illustration carefully.

Place Sticker Cam (C) over the Connecting Cams (B).

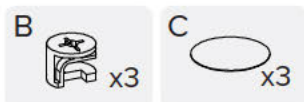
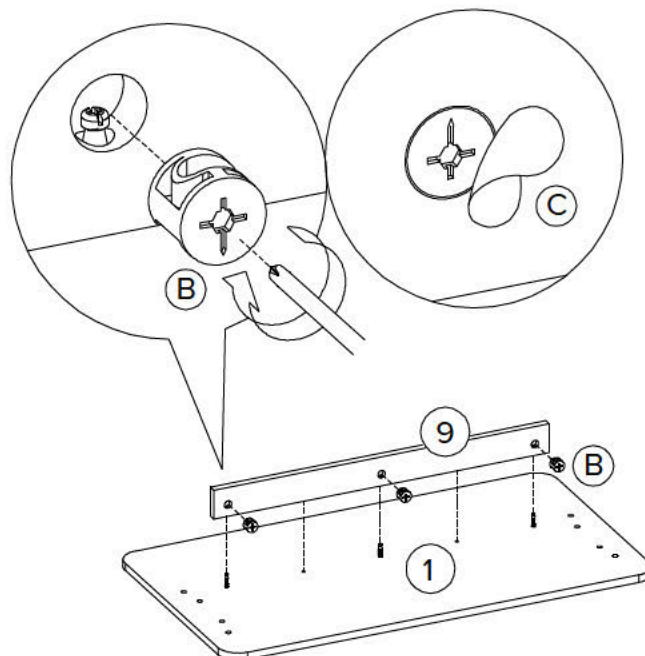

Step 13

Install the panel (1) onto Assembled Unit.

Use Bolt (H) & Washer (I) to lock and tighten.

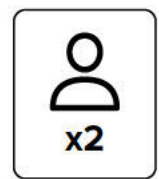
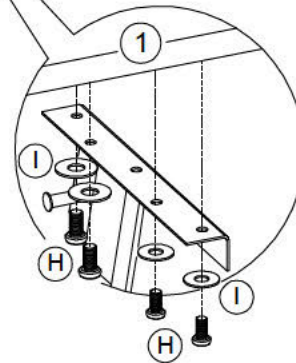
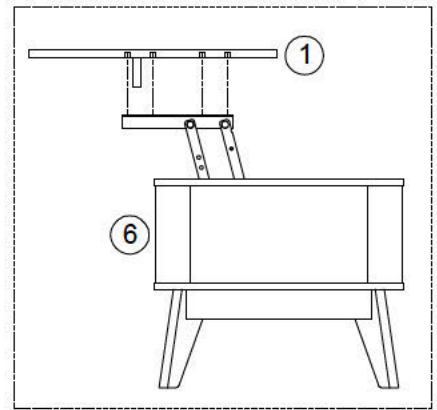
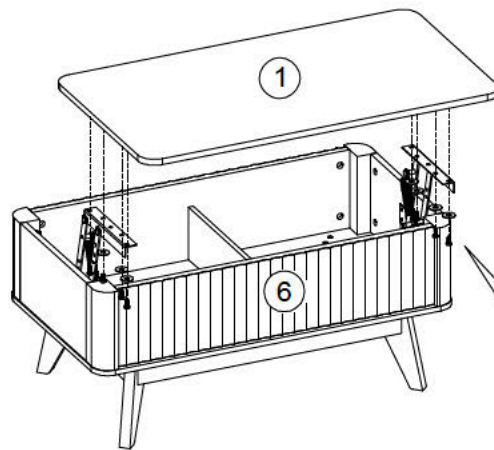

Step 14

Fasten Metal Support (K) onto Elevating table.

Use Bolt (M), Washer (J) and Nut (N) to lock and tighten.

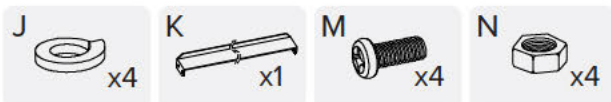
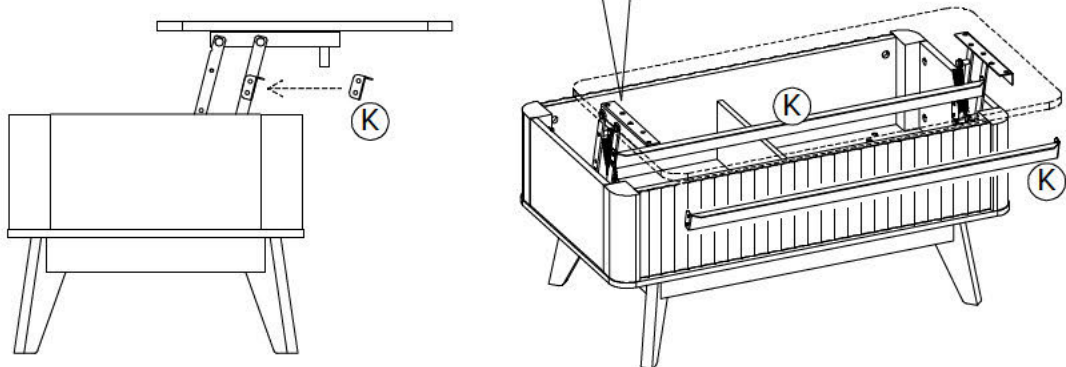
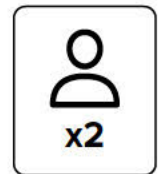
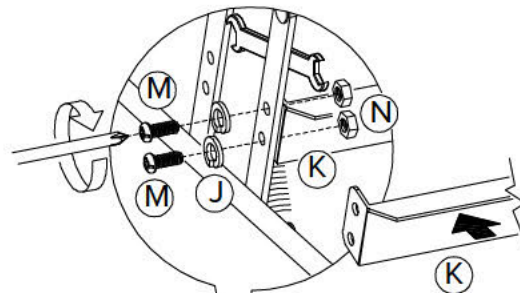

Step 15 - Safety Tips

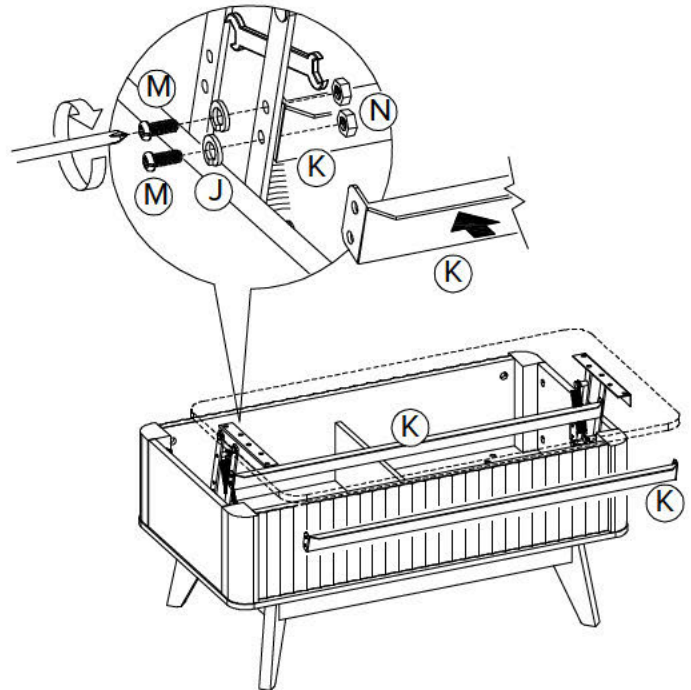
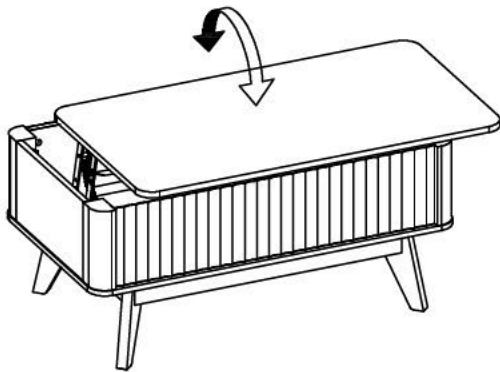

If you have difficulties on opening / closing the table top,

* If table top is hard to open or close, it may be caused by over-tightening of screws on Step 14.

* If opening or closing of table top is too fast, it may be caused by loose screws on Step 14.

Please adjust the screws according to your preferences.



Always close the table top carefully and ensure that there are no fingers in between the gaps.

Do not let children operate the lift top mechanism without any adult supervision.

Always lift the table top using both hands at both sides of the table top and lift it at the same time.
Keep your grip when opening the table top to avoid unexpected movement created by spring mechanism.

Lifting the table top using 1 hand at any one side may result in imbalance opening.

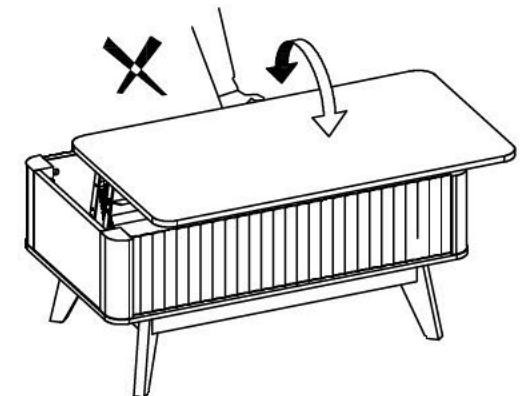
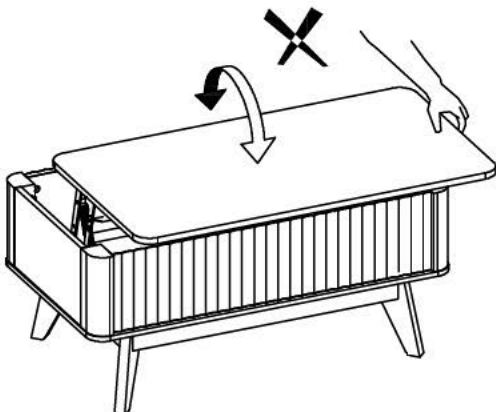
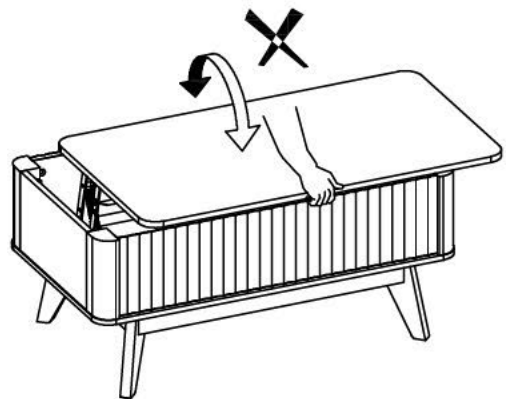
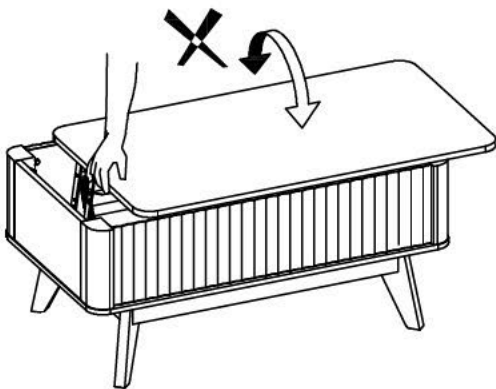
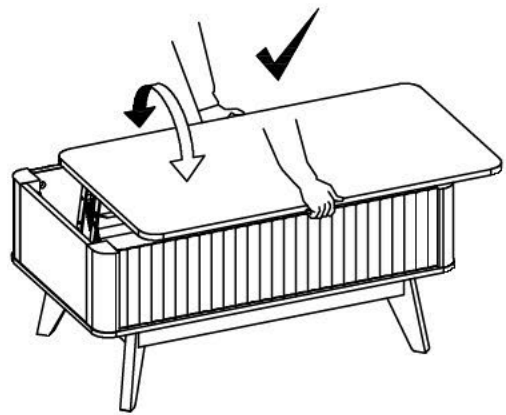
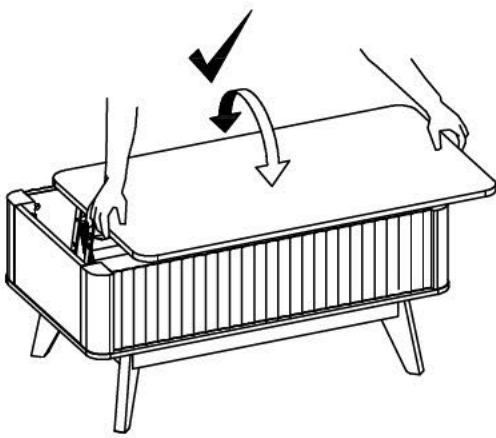
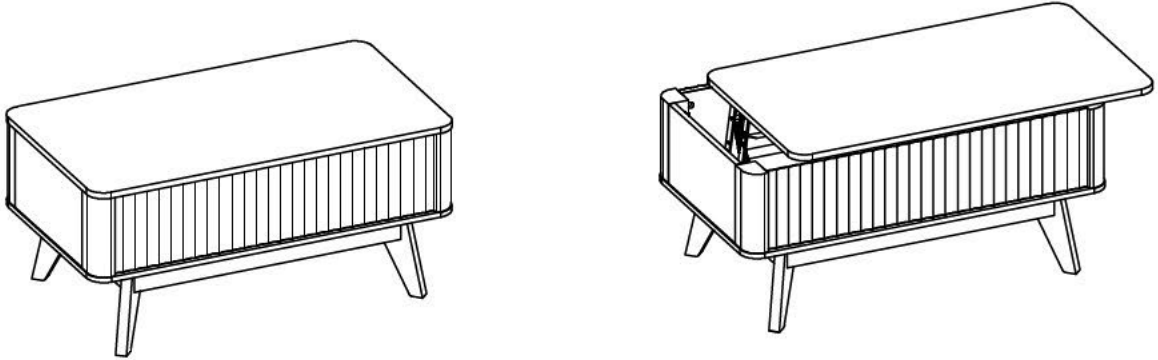

When table top is opened.

Please load the table top evenly in the middle to maintain its stability. Do not load the table top on the edge.

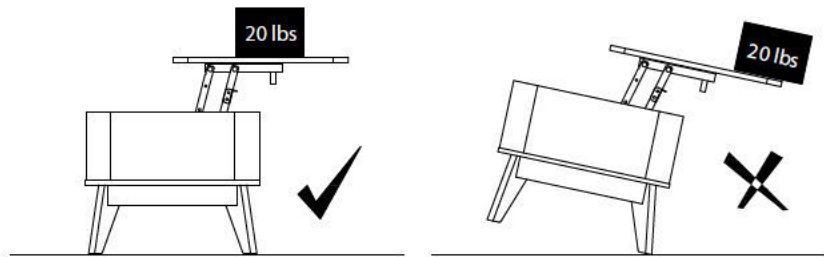

When table top is lowered down, it can hold up to 50lbs

When table top is opened / extended, max load is 20lbs (evenly distributed load in the middle)

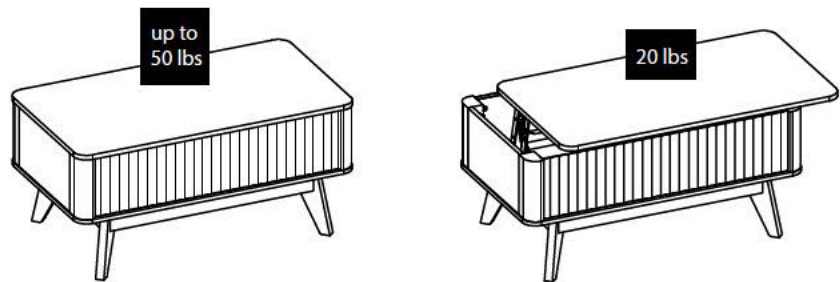

Please do not lean or sit on the table top when it is lifted open.

This may cause the table to topple over and/or injury to yourself.



Please do not place any object on the table top while lifting, lowering, or moving the table.

This may cause the table top to fall.

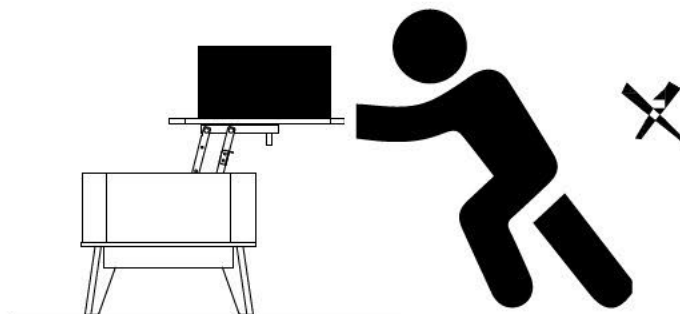

Finished!

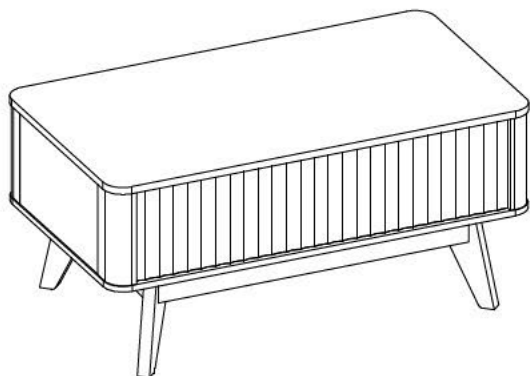

Congratulations! We're almost there! Please perform following checks to ensure assembly is properly done.

- Ensure there is no loose camlock or screw.
- Ensure all legs are fully tightened and not shaking. (refer to step 8 and 10).
- If the table-top is misaligned, please refer to step 13 and adjust accordingly.

Move your Mopio product carefully, with 2 people lifting it to the preferred location. Clean the product with a damp cloth. You are all set!

Enjoy your fresh and updated living space thanks to the addition of your new Mopio product!

Care

Instructions

Your furniture, if treated with respect and love, will last you a long time. Each piece requires light maintenance to maximize its longevity.

Few quick tips before using this product:

1. Recommended weight limit for the top is 50 lbs and 15 lbs for each of the shelf compartment.
2. Avoid uneven weight distribution for long time as it may cause damage to the product shape.
3. Drawers might not slide smoothly when dresser is overloaded by weight.
4. Check and tighten the camlock and screw periodically as it may loose over the time.
5. Check anti tipping screw periodically, change the screw position if it start to lose.

How to take care of it?

1. Avoid direct sunlight or use curtains or blinds to limit the sun exposure to the product.
2. Clean the product regularly with a dry, soft cloth.
3. Avoid using abrasive or liquid cleanser.
4. Avoid placing hot objects onto the top surface.
5. Spillage may damage the surface. Clean immediately with a dry cloth.
6. We recommend using placemats or coasters underneath glasses, cups, bowls or plates to prevent scratches to the table surface.

Follow the care instructions and look after your furniture, in return, your furniture will look after you.

We hope to see you soon!

Frequently Asked Questions

1. What should I do if my product received is incomplete?

products are flat packed and come in separate boxes. Once your order has dispatched and been sent with Fedex, you will receive an email with tracking information. Please note that Fedex may deliver your boxes in separate deliveries. Kindly follow the tracking information, allowing all boxes to be received before starting assembly. If you need further assistance on deliveries tracking, feel free to reach out to us.

2. What should I do if my shipment is damaged or products received are defective?

We're sorry to hear that! Please email us or chat with us at and provide a detailed description of the damage, as well as photos (or videos, where appropriate) showing the damage. We will do our best to resolve the issue as soon as possible.

3. Can replacement parts be ordered?

Yes. Simply write to our customer service team or chat with us let us know your order ID and we will be happy to assist further.

4. Who do I contact for repair queries?

You may write to us specifying your queries and we will be able to assist you further.

5. What warranty do you offer for your products?

You'll just need to submit your warranty registration upon receiving product and it comes with one year warranty period. You can print a copy of your order from Order Details in Amazon and upload it as your proof of purchase. More details can be found in **Warranty section**.

6. How do I claim my warranty?

Easy! Just email us and provide a detailed description of the fault as well as photos.

7. What should I do if I want to return the product?

We offer 30-day return policy upon product received. To initiate a return request, please message us through Amazon or contact our customer service team or with your reason of returning so we can facilitate the request and assist you further. For more details on the return policy, please refer to **Return section**.

Warranty & Return

1 YEAR LIMITED WARRANTY STATEMENT FOR MANUFACTURING DEFECTS

Please read this limited warranty carefully. To maintain your warranty, you will need to comply with the conditions stated here. This warranty is for manufacturing defects only and does not cover damages as a result of misuse.

1. Please be sure to register your product to receive up to date warranty and product information.
2. Your new product comes with 1-year warranty against manufacturing defects. The warranty starts on the date of purchase. No warranty will be honoured without an original sales receipt. The warranty and financial responsibility of the manufacturer only applies to the products itself.
3. Manufacturing defects include circumstances where the product has broken under normal use and no longer provides proper support. In the event you encounter a manufacturing defect, please stop using this product immediately and contact customer service.
4. This warranty applies only when the product has been properly used by consumers who purchased the product from authorized channels as a new product. Proper use means using the product on a level surface where all legs touch the floor with an equal distribution of weight. Proper use also means that the product was not abused by the consumer, as defined by the manufacturer. This warranty does not constitute agreement to replace other parts.
5. If the product fails due to manufacturing defects, the manufacturer will repair or replace at its discretion and reserves the right to substitute comparable materials or models and does not guarantee that the replacement part will match existing pieces.
6. In the event the product needs to be inspected by the manufacturer to determine a warranty claim, the transportation cost or removal cost is borne by the consumer.

30-DAY RETURN POLICY

We believe you will be thrilled with your purchase. That's because we go out of our way to ensure that products are designed and built to be just what you need. We understand, however, that sometimes a product may not be what you expected it to be. In that event, we invite you to review the following terms related to returning a product.

The Return

Returns are to be made within 30 days of the date you received the product. To initiate return request, please message us or contact our customer service team with your reason of returning so we can facilitate the request and issue return authorization to you. Please note the policy is subject to the conditions below:

1. Only undamaged items in original packaging will be accepted under the Returns Policy. Any items that are not returned to us in the original packaging and/or in original condition will incur an additional handling fee (deducted from your refund). It is your responsibility to package the item sufficiently to avoid damage in transit back to us. We encourage customers to photograph the items scheduled for return and the condition of the packaging before handing over to the delivery company.
2. We will not refund a product that you have bought and received where, in our reasonable opinion, the product has: become of unacceptable quality due to fair wear and tear; misuse; using it in an abnormal way; or failure to take reasonable care.
3. We will not be able to offer standard return policy after 30-day timeframe has passed. However, our customer service team is always an email away if you require further assistance with your products.

The Refund

We will assist you to complete the return process. We will perform standard inspection upon your return is received and will send you a message to acknowledge the return if item is presenting in original condition with original packaging.

You will be refunded the full amount less return shipping cost. Please note that while shipping charges on original deliveries are subsidized, on returns the full shipping amount paid by us to the delivery partner will be deducted from your refund. **All refunds will take 2 business days to process upon return acknowledgement from us, however actual fund reversal date will depend on your card company's own processing schedule.**

Kindly note, in the event of returning a defective or damaged item, **we will however absorb the shipping charges and ensure your return/exchange experience is hassle free.**

The Exchange

We put quality as one of our top priorities – we work with experienced manufacturers and have every piece of product going through strict quality control process. We want to make sure your product reaches you safe and sound, however we are happy to do an exchange in case you receive a defective or damaged product due to any unforeseen hiccups throughout the journey. Please message us or email us with proof of defect or damage, our customer service will evaluate the exchange request, and assist you throughout the process accordingly.