

leggett & platt®

fashion bed™

6755 W. 65th Street Bedford Park, IL 60638

Part List For Java I bed

PARTS ENCLOSE:

- (6) HEADBOARD-1
- (7) FOOTBOARD-1
- (8) SIDE RAILS-2
- (9) SLAT SYSTEM-14
- (10) CENTER SUPPORT RAIL-1
- (11) LONG SUPPORT LEG-2 (USE FOR MATTRESS ONLY)
- (12) SHORT SUPPORT LEG-2 (USE FOR BOX SPRING & MATTRESS)

PART #389402 HARDWARE BAG FOR BED

- (1) 6mm X 3/4" FLAT ALLEN HEAD SCREW-8
- (2) 5/16" ID METAL WASHER-8
- (3) 6mm X 1 1/2" FLAT ALLEN HEAD SCREW-6
- (4) 1 1/4" FLAT PHILLIPS COUNTERSUNK HEAD WOOD SCREW-8
- (5) ALLEN WRENCH 4mm

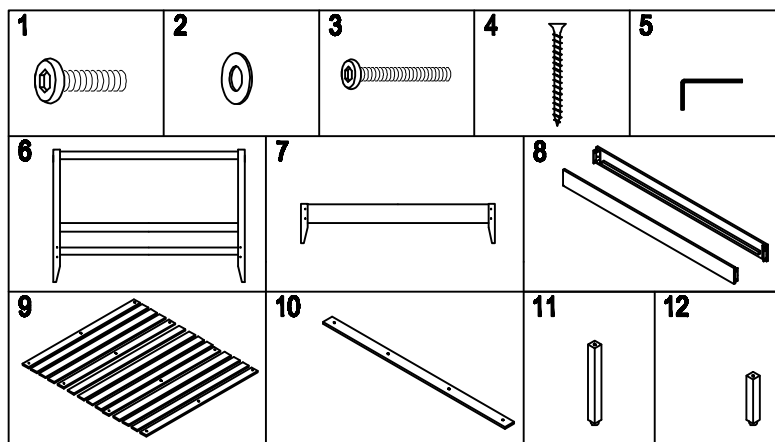

SAVE ALL PACKAGING MATERIALS UNTIL PRODUCT IS FULLY ASSEMBLED. HARDWARE AND SMALL PIECES MAY NOT BE SEEN AND COULD BE ACCIDENTALLY DISCARDED WITH PACKAGING MATERIALS.

NOTE: THIS MODEL HAS THE OPTION TO USE A MATTRESS ONLY OR BOX SPRING AND MATTRESS.

- USE PAGE 2 OF 3 TO SET UP BED WITH MATTRESS ONLY. (USE LONG SUPPORT LEG)
- OR
- USE PAGE 3 OF 3 TO SET UP BED WITH BOX SPRING AND MATTRESS. (USE SHORT SUPPORT LEG)

- Step 1**
- Place headboard (6) and side rails (8) in desire location in the room.
 - Secure side rails to headboard posts with screw (1) and washer (2). (See Figure 1)
 - Tighten all screws
 - Do the same for the Footboard (7) attachment.

- Step 2**
- Place slat system (9) between side rails (8). (See Figure 5)
 - Secure center rail (10) to center holes in slat system (9). (See Figure 5 & 2)
 - Use screws (3) to secure each location. Tighten all screws

- Step 3**
- Secure support legs (11 or 12) to center rail (10) with screws (3).
 - (See Figure 3 & 5) Tighten all screws

- Step 4**
- Secure both ends of slat system (9) to the side rails (8) with screw (4). (See Figure 4)
 - Tighten all screws

PRODUCT FULLY ASSEMBLED

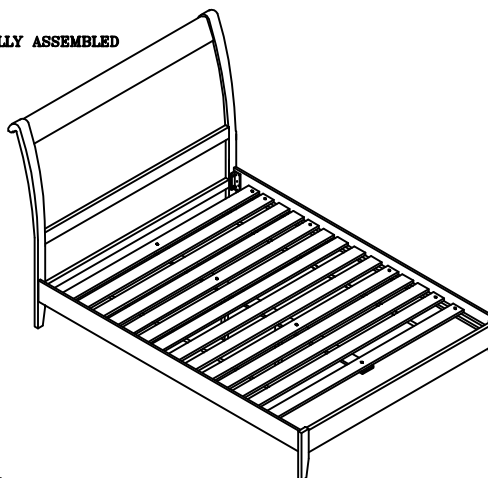

FOR ASSISTANCE IN ASSEMBLY ONLY OF THIS PRODUCT. CALL OUR HELP DESK AT 1-800-324-3415, BETWEEN 8:30 AM & 4:30 PM CENTRAL TIME MONDAY THRU FRIDAY. PLEASE HAVE THE STYLE NUMBER AVAILABLE BEFORE YOU CALL. (STYLE # OR NAME CAN BE FOUND ON PACKING CARTON OR SALES RECEIPT.) OUR PRODUCT IS INSPECTED TO ENSURE IT IS IN GOOD CONDITION. IF YOUR FURNITURE APPEARS TO HAVE BEEN DAMAGED IN SHIPMENT OR YOU ARE IN NEED OF REPLACEMENT PARTS PLEASE CONTACT THE DEALER FROM WHOM YOU PURCHASED THE PRODUCT.