



















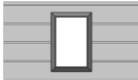
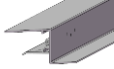
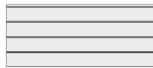

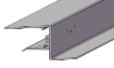



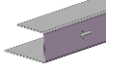
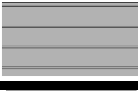

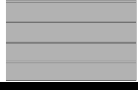



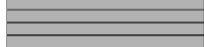



Packing list		
Box A		
serial number	Number of layers	The item number
1	1-1	WA-03
2	2-1	WA-03
3	3-1	WA-03
4	4-1	FA-01
5	5-1	FA-01
6	6-1	FA-02
7	7-1	WA-08
8	8-1	WA-04
9	8-2	JTMB-WA-01
10	9-1	WA-04
11	9-2	JTMB-WA-03
12	10-1	WA-09
13	10-2	WA-09
14	10-3	WA-09
15	10-4	WA-09
16	11-1	WA-01
17	12-1	WA-01
18	13-1	WA-01
19	14-1	WA-01
20	15-1	WA-01
21	16-1	WA-01
22	17-1	WA-01
23	18-1	WA-02
Box B		
serial number	Number of layers	The item number
1	1-1	RA-01
2	2-1	RA-01
3	3-1	RA-02
4	4-1	WA-01
5	5-1	WA-01
6	6-1	WA-01
7	7-1	WA-01
8	8-1	WA-01
9	9-1	WA-01
10	10-1	WA-01
11	11-1	WA-01
12	12-1	JTMB-WA-02

13	13-1	JTMK-WC-01、JTMK-WC-02、JTMK-WC-03、JTMB-WC-01、JTMB-WC-02、JTMB-WC-03、WB-01、WB-02、WB-03、WB-04、WC-01
----	------	-------------------------------------------------------------------------------------------------

Box C

serial number	The item number	Quantity/set
1	JTRB-04	2/套
2	JTRB-02	4/套
3	JTFB-01	4/套
4	WD-03	2/套
5	WD-01	2/套
6	WD-02	1/套
7	KYN28A-12	1/套
8	JTMK-WC-04	4/套

List of Materials

NO.	PART.	Qty.		NO.	PART.	Qty.
WA-08		2		RB-01		2
FA-01		3		RB-02		4
FA-02		1		JTRB-02		4
WA-01		15		JTRB-04		2
WA-02		1		JTMK-WC-01		1
WA-03		4		JTMK-WC-02		2
WA-04		1		JTMK-WC-03		1
WA-06		1		JTMK-WC-04		4
WA-09		4		JTMB-WC-01		2
JTMB-WA-01		1		JTMB-WC-02		2
JTMB-WA-02		2		WD-03		2
JTMB-WA-03		1		WD-01		2
RA-01		2		WD-02		1
RA-02		1		ST4.2X20		106
JTFB-01		4		ST4.2X12		54
WB-02		2		ST4.2X26		20
WB-03		2		STYW4.2X12		26
WB-01		4		JTTY-D-01		1
WB-04		2				
WC-01		2				

flooring components

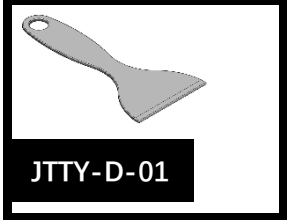
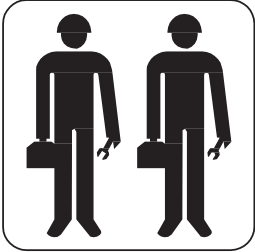

Note: The crease line of the floor must be underneath

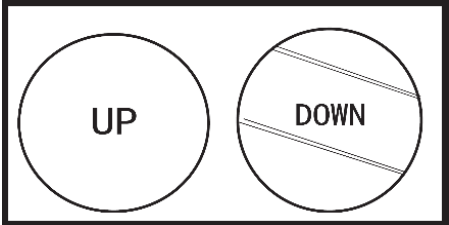

Use a spatula to make it easier to insert the panel

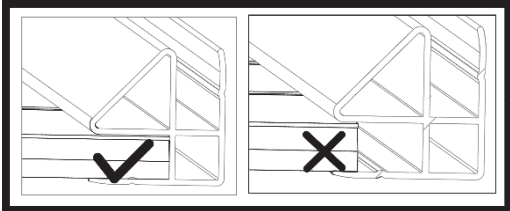
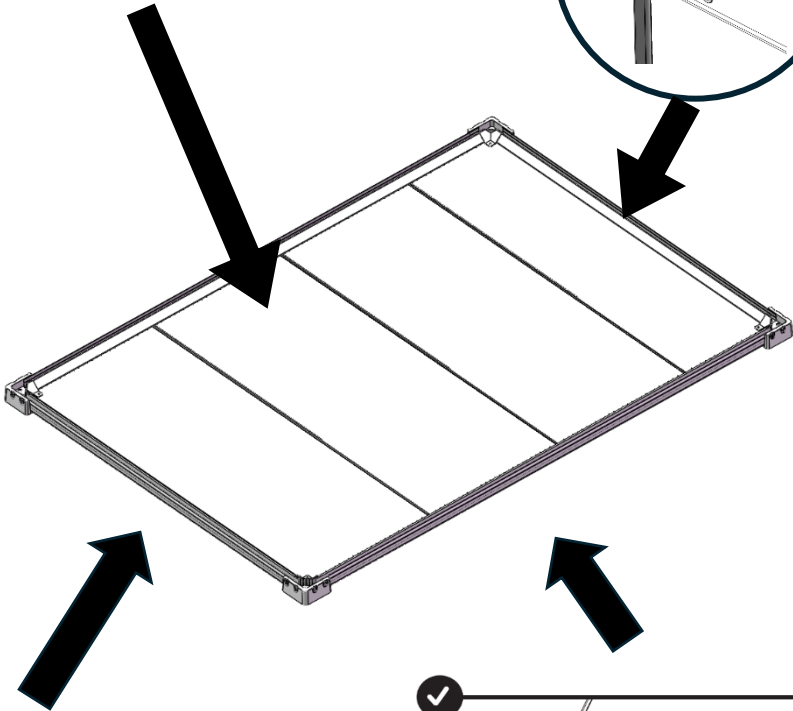
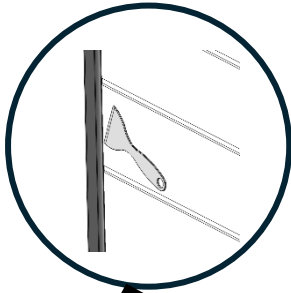

The panel fits perfectly inside the profile

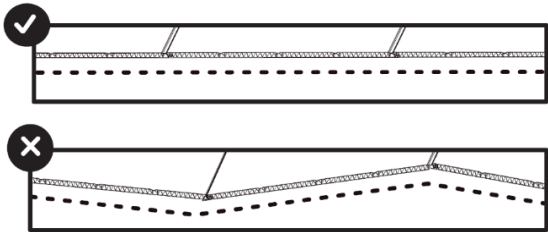

During installation, the plate remains vertical and cannot

Step 1

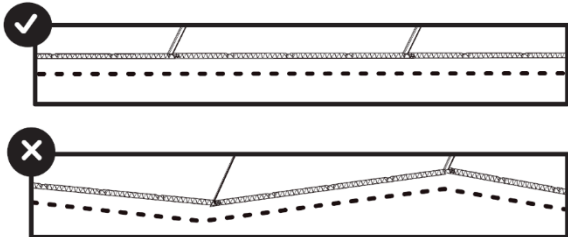
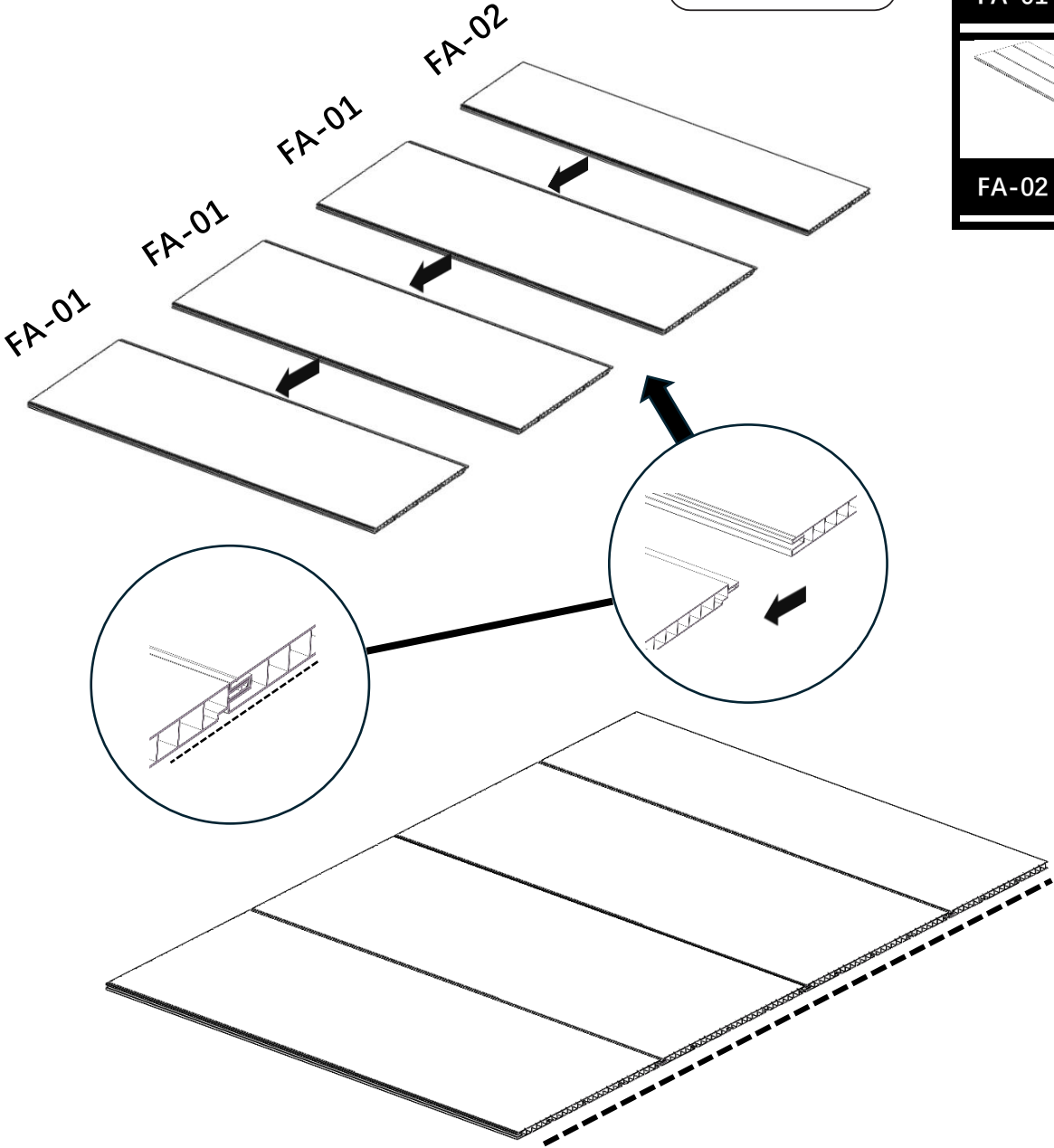
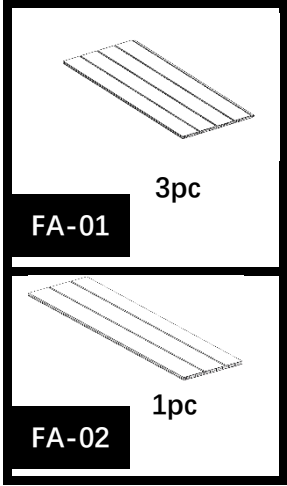
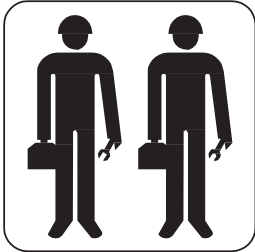

During installation, the plate remains vertical and cannot be bent

Step 2

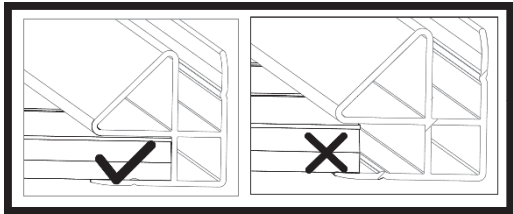

The panel fits perfectly inside the profile

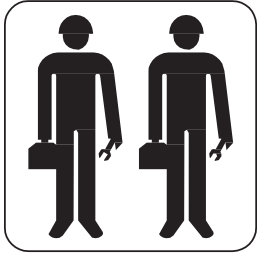

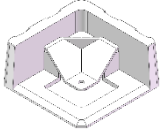
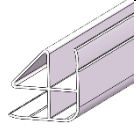
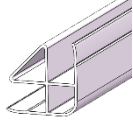
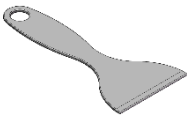
- 1pc  JTFB-01
- 1pc  WB-02
- 1pc  WB-03
-  JTTY-D-01

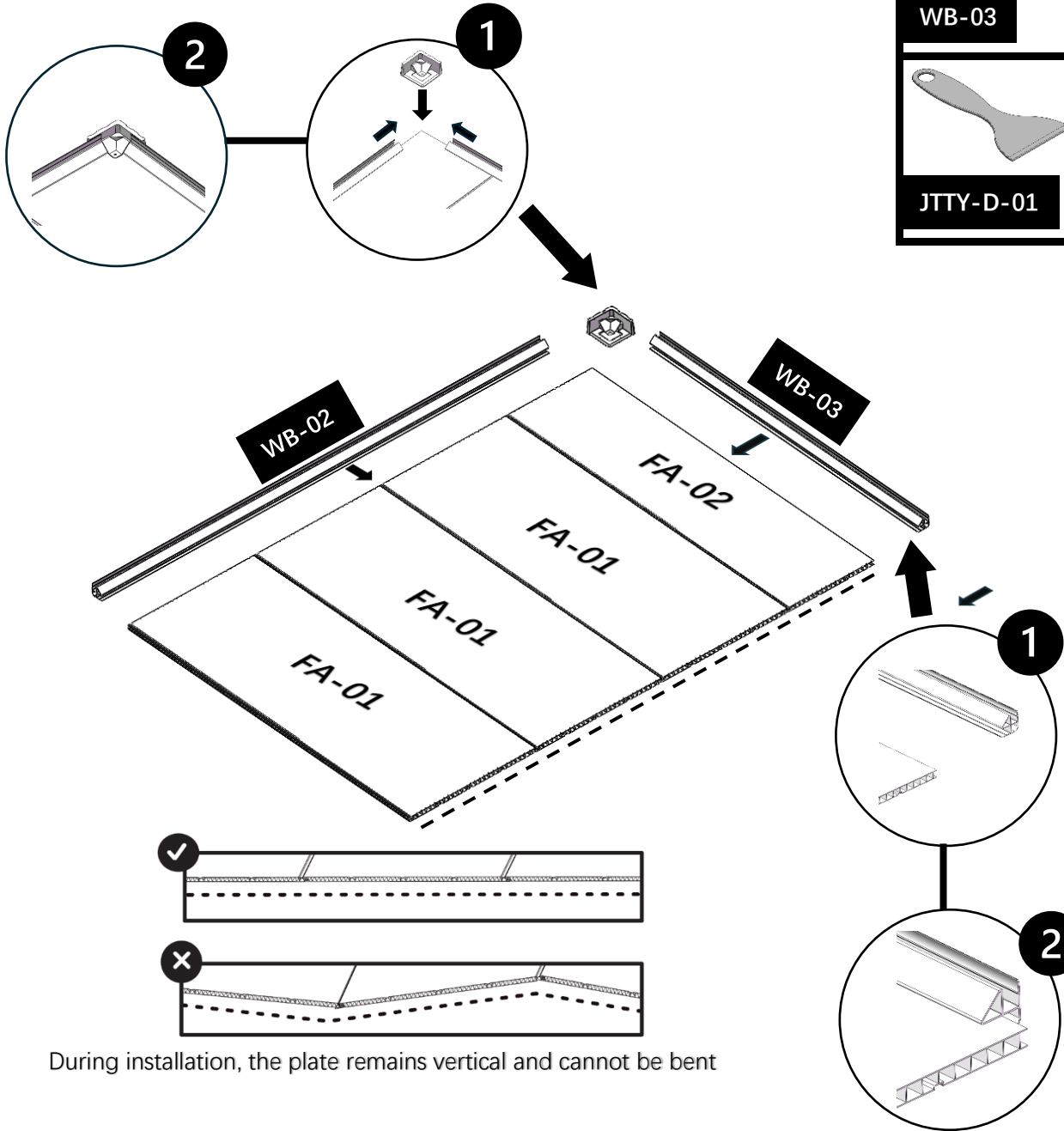

During installation, the plate remains vertical and cannot be bent

Step 3

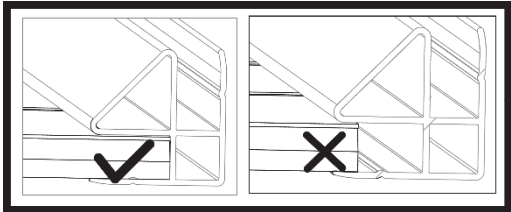

The panel fits perfectly inside the profile

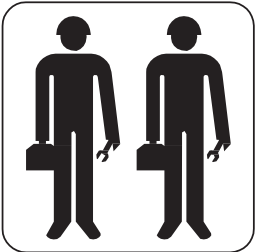

1pc	
JTFB-01	
1pc	
WB-03	
JTTY-D-01	

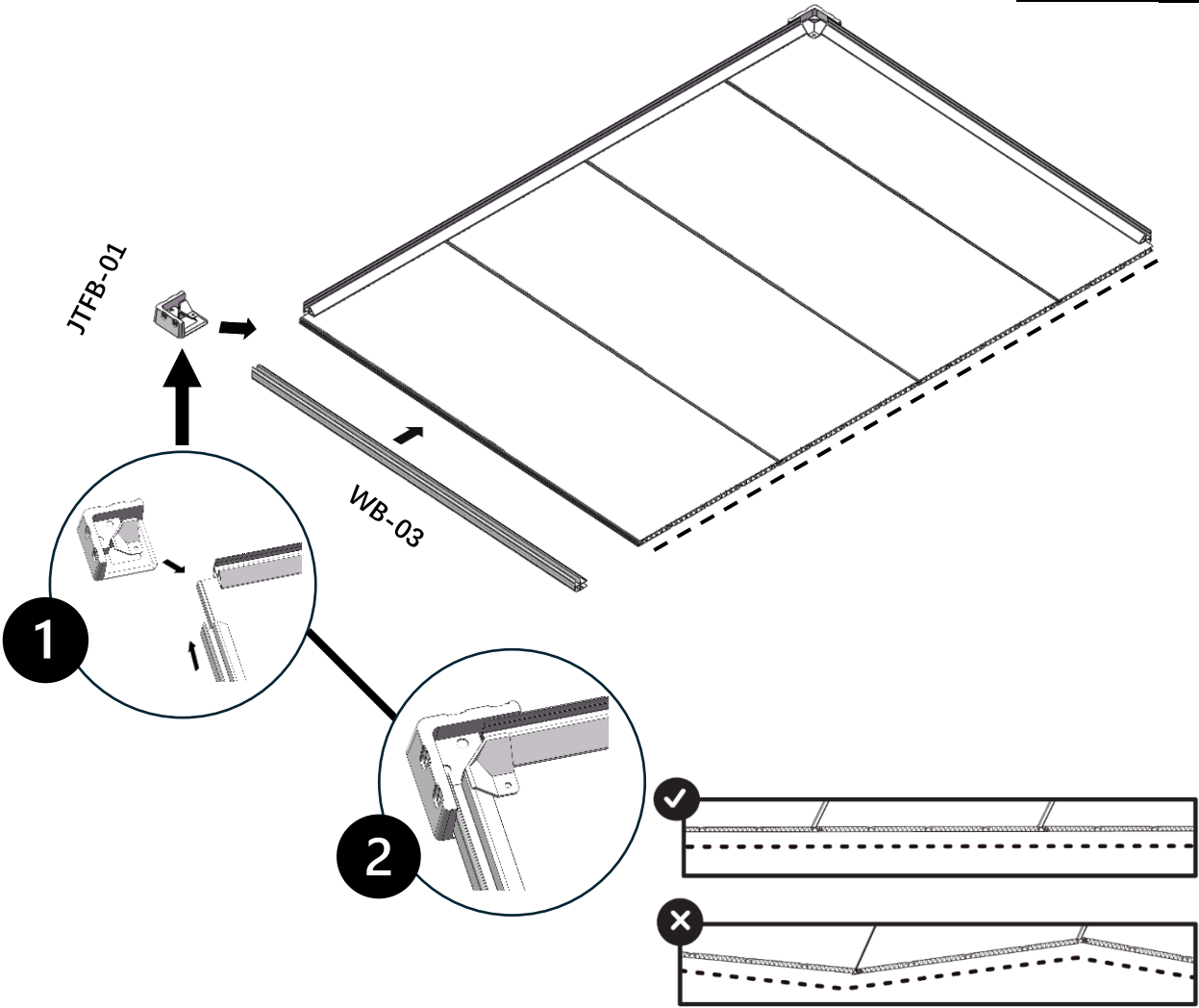

During installation, the plate remains vertical and cannot be bent

Step 4

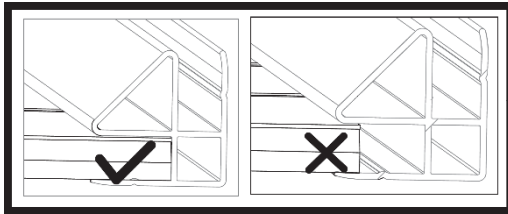

The panel fits perfectly inside the profile

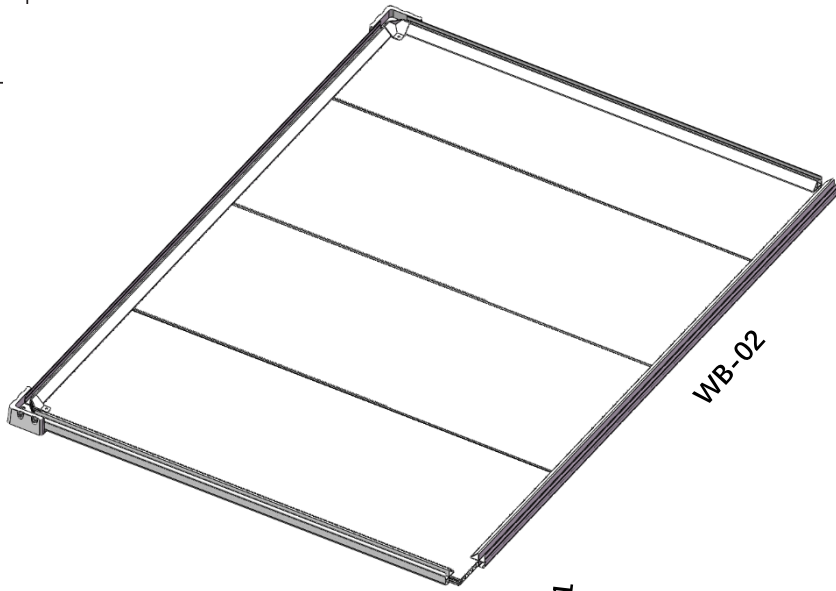
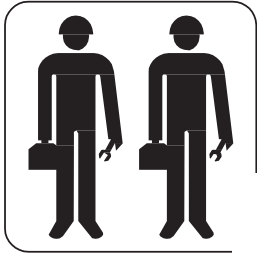

1pc	
JTFB-01	
1pc	
WB-02	
JTTY-D-01	

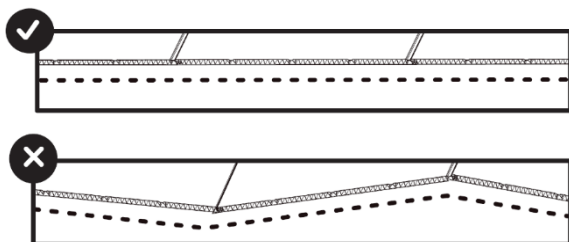
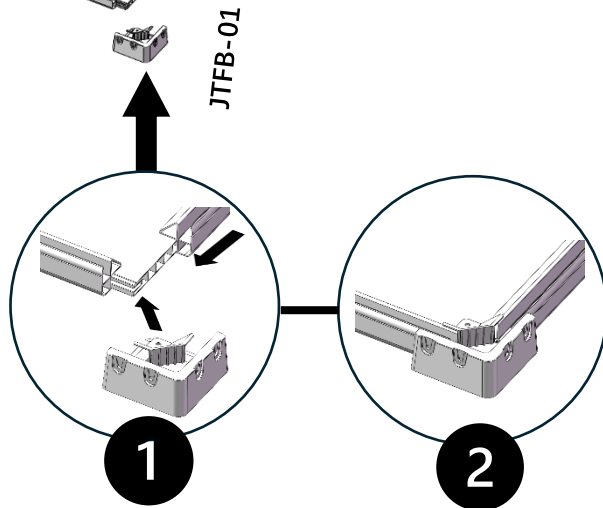

During installation, the plate remains vertical and cannot be bent

Step 5

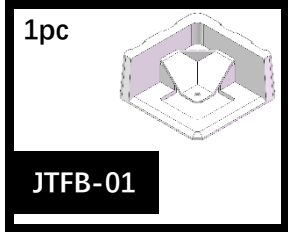
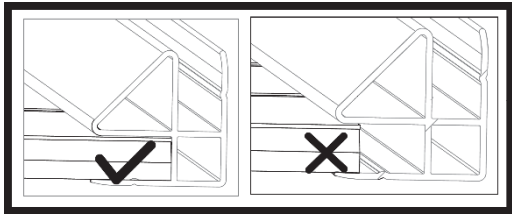

The panel fits perfectly inside the profile

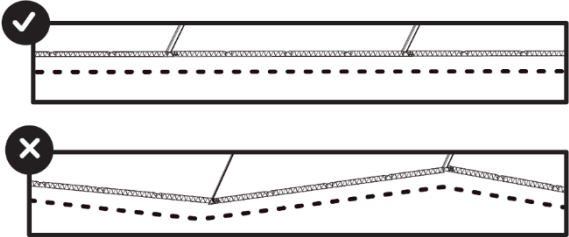
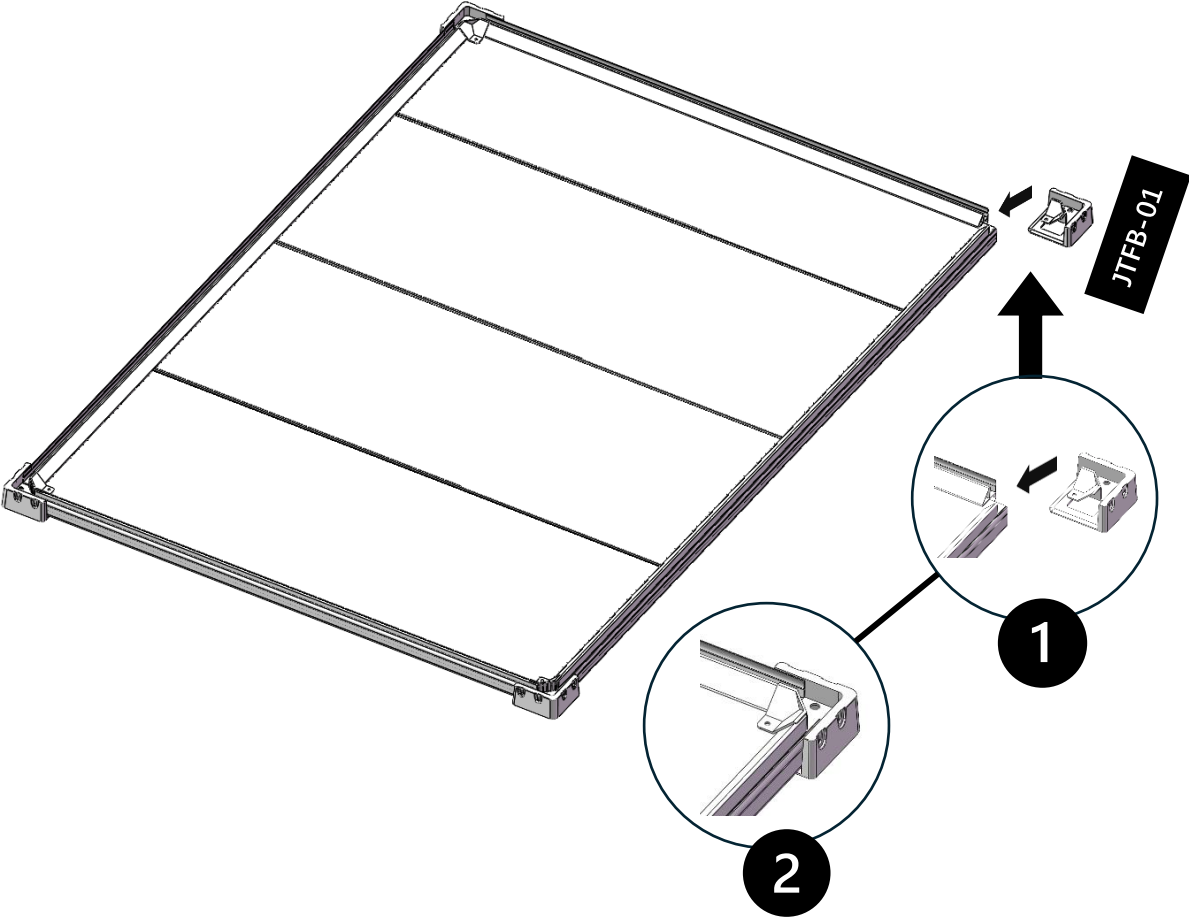

During installation, the plate remains vertical and cannot be bent

Step 6

4pc



ST4.2X12

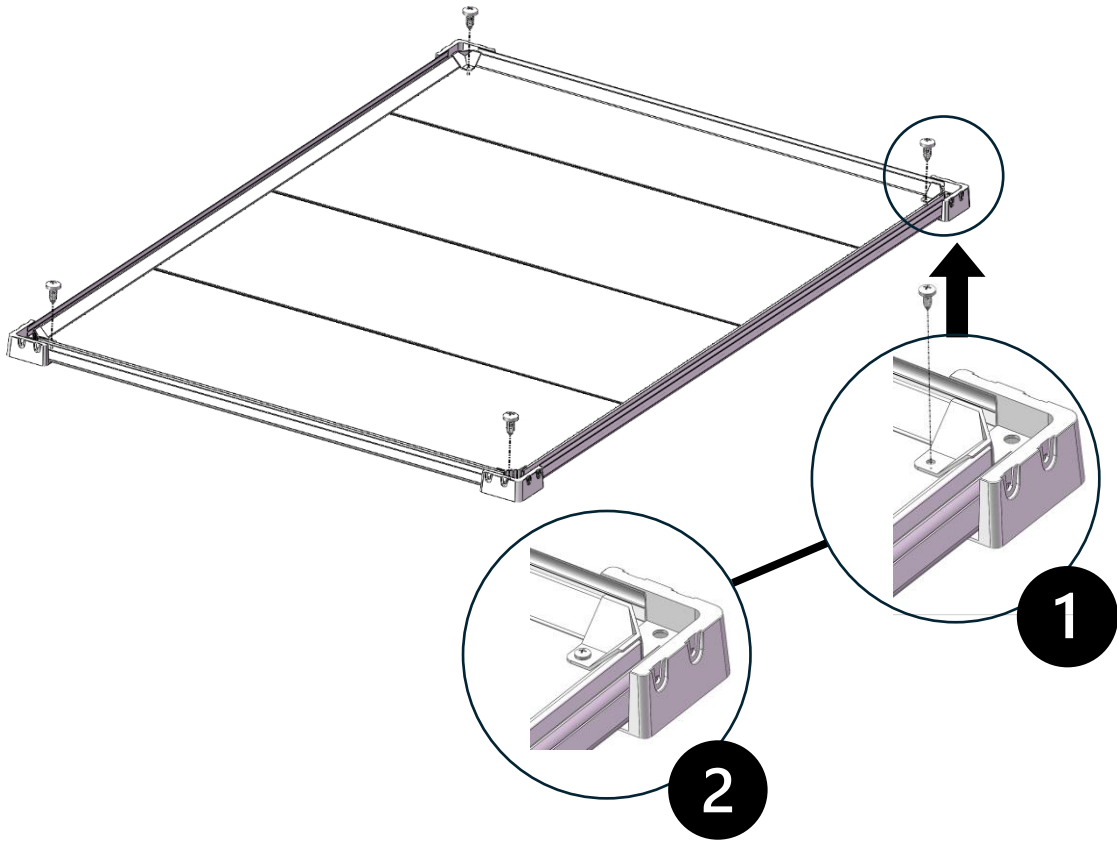
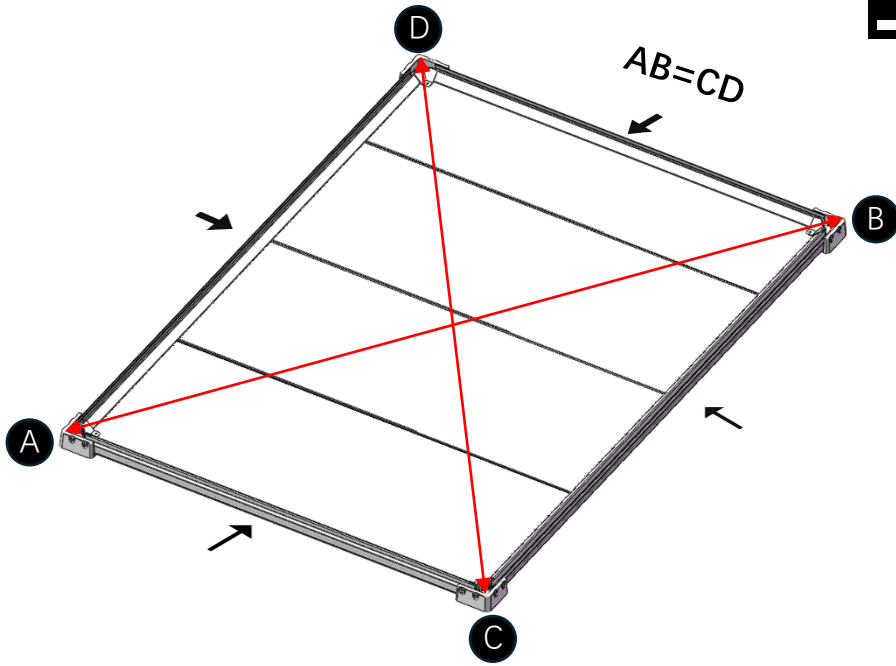

Step 7

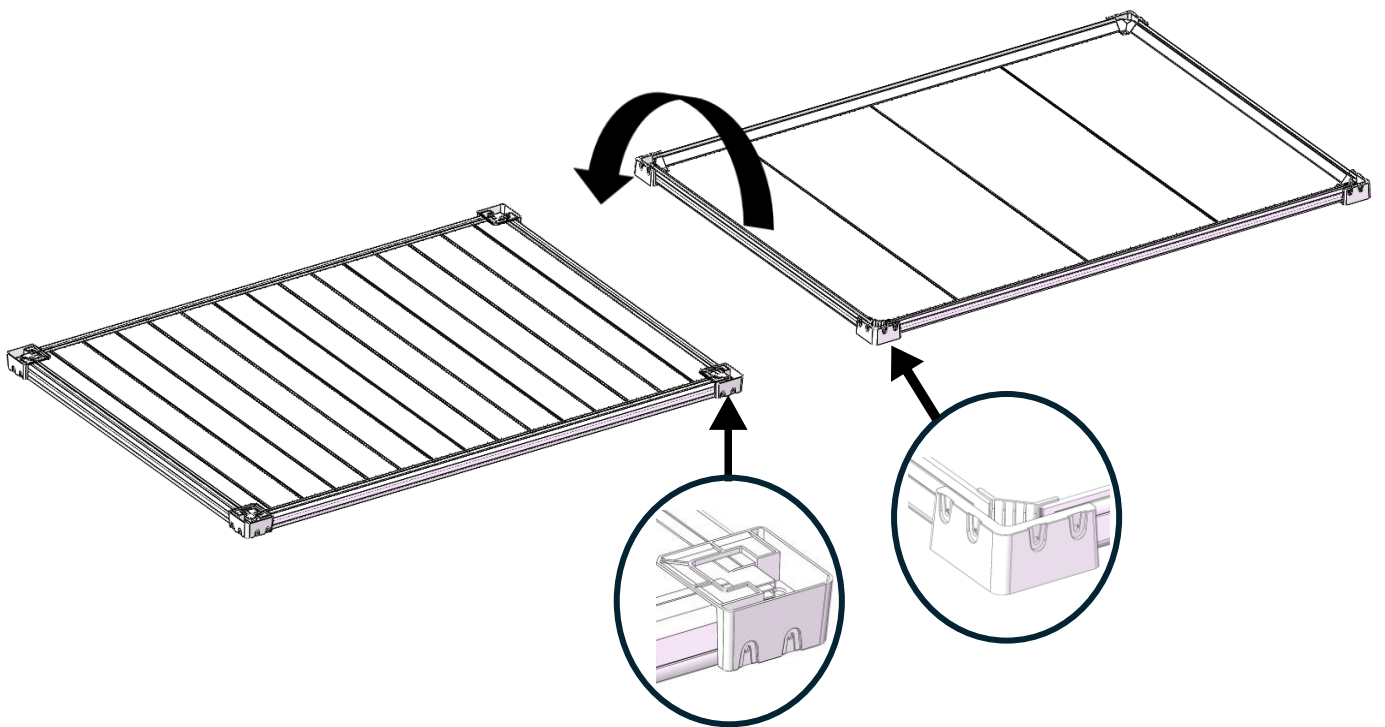

Step 8

12pc



ST4.2*20

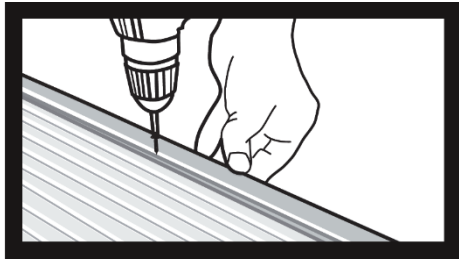

Fix the screws on the profile along the marking line

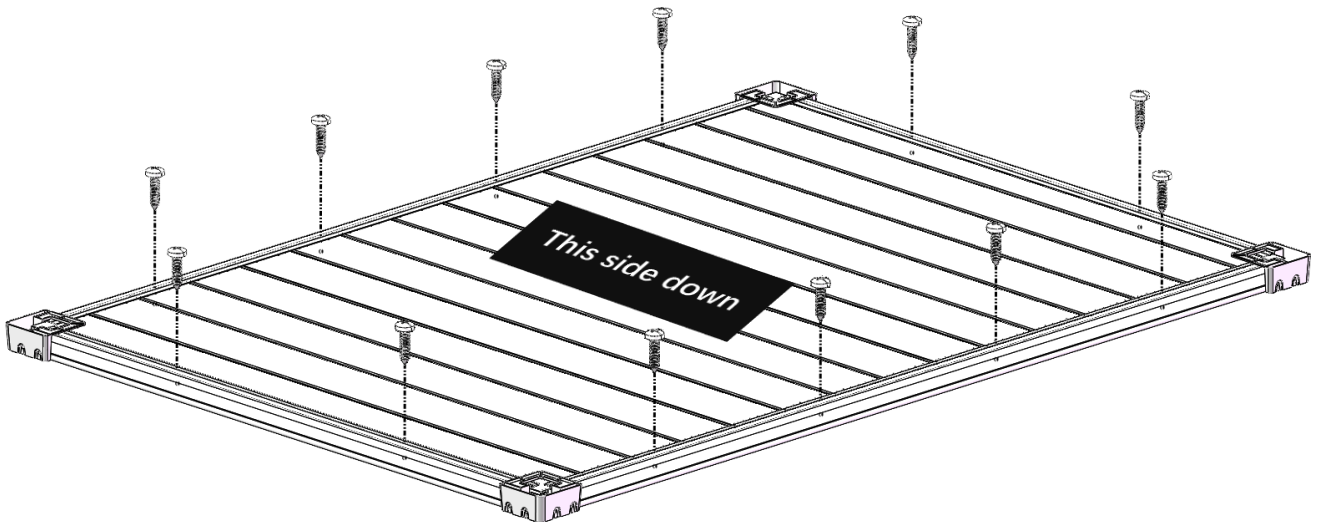

Step 9

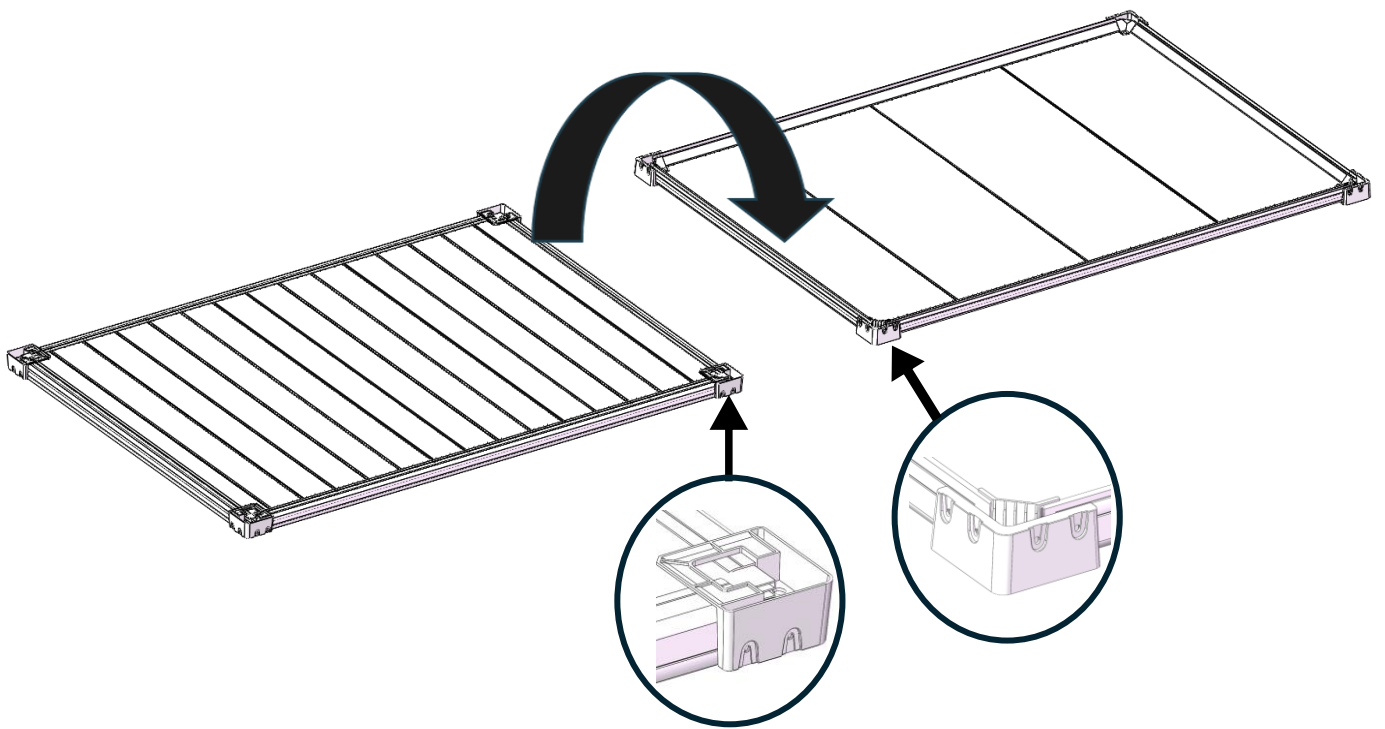

Wall installation

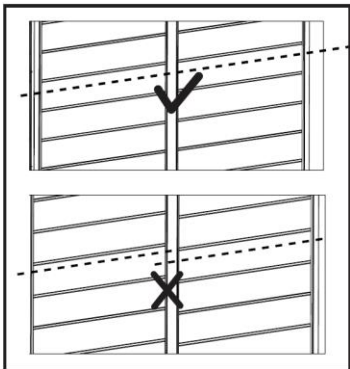
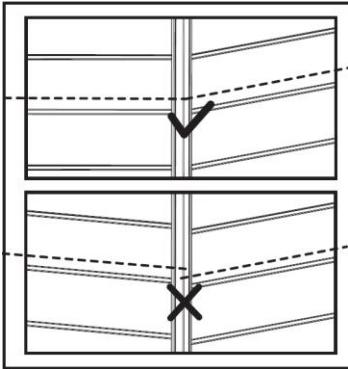
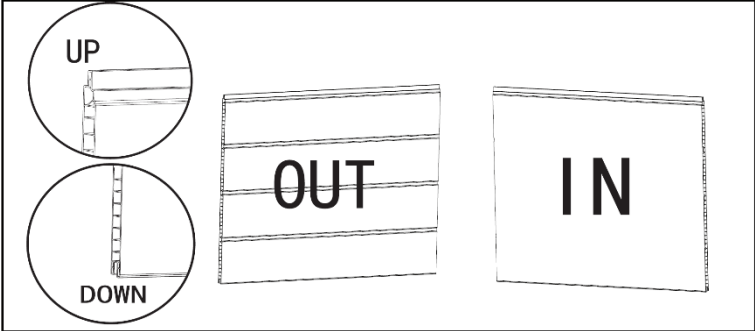
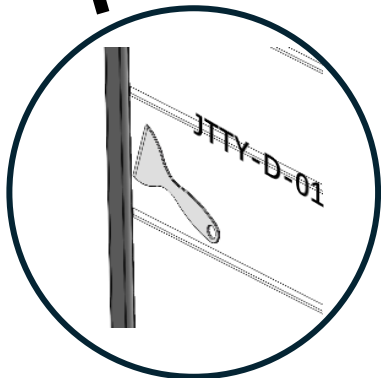
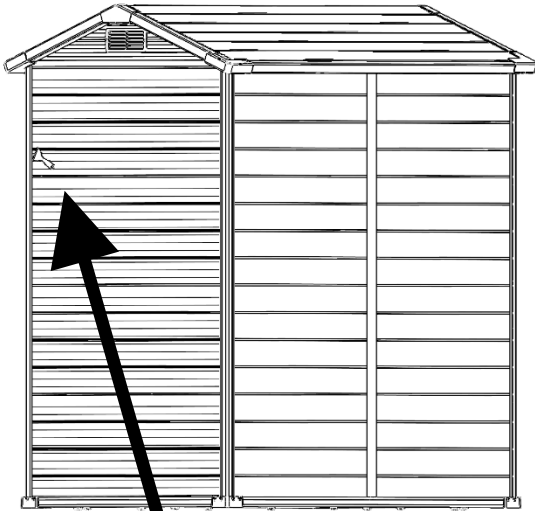

Use a spatula to make it easier to insert the

Step 10

1c

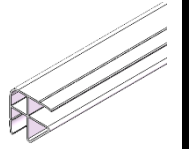

WB-01

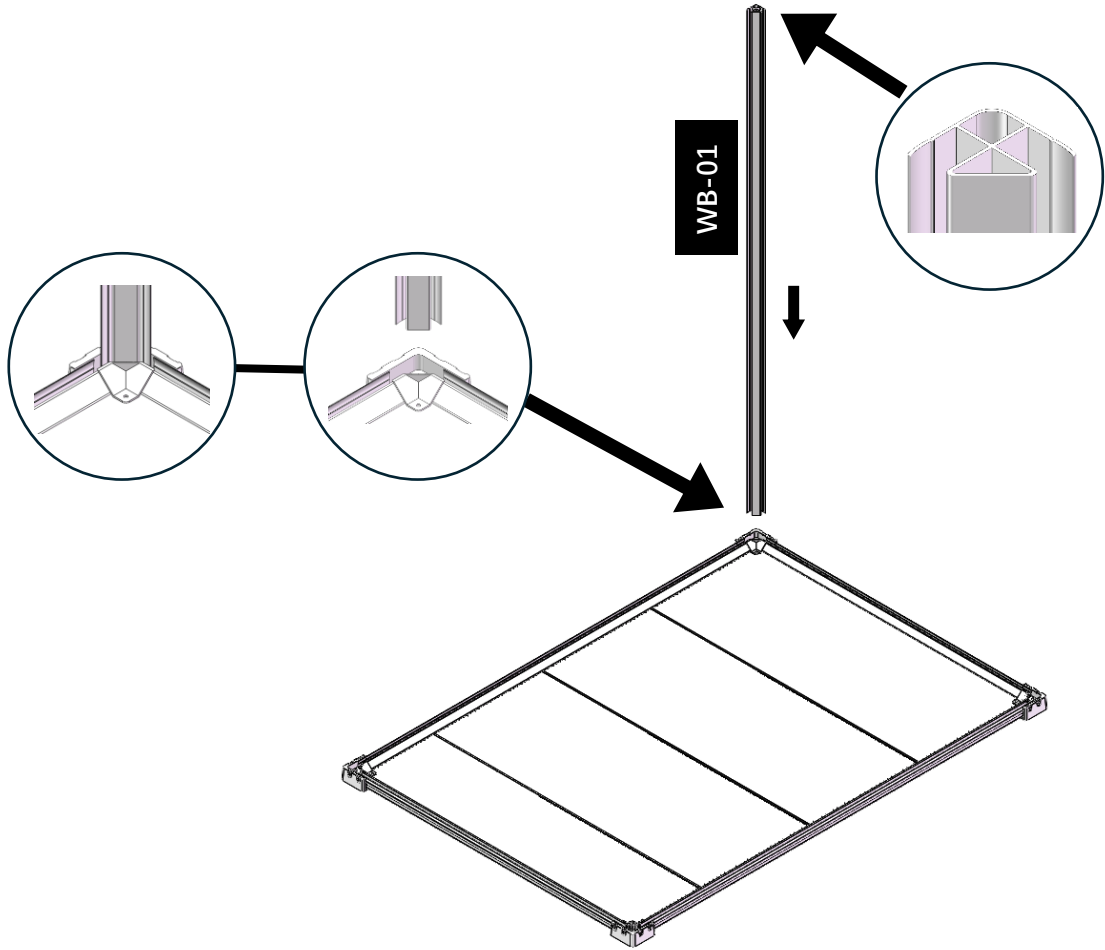

Step 11

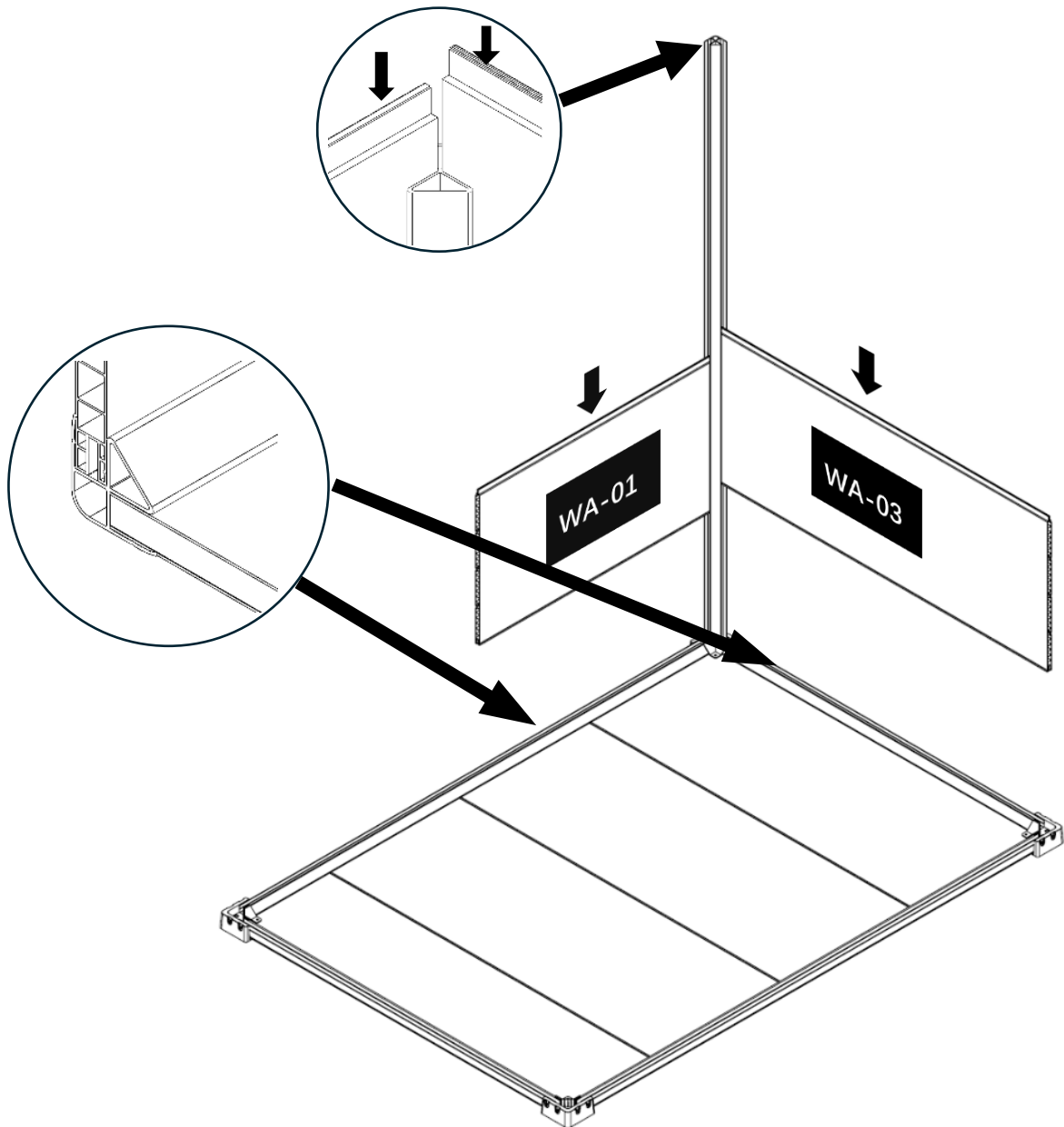
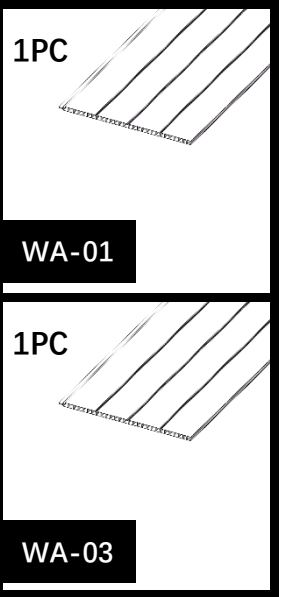

Step 12

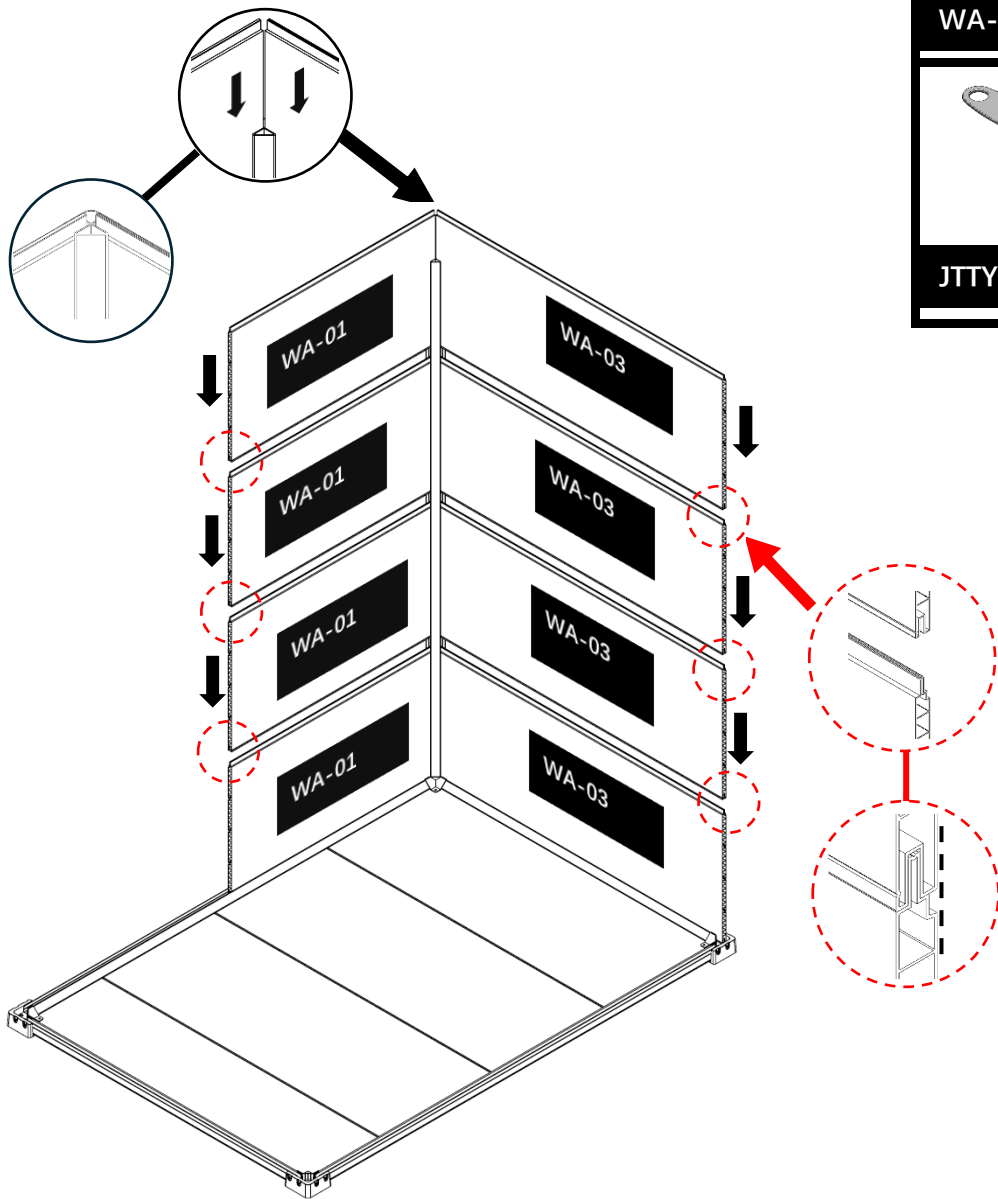

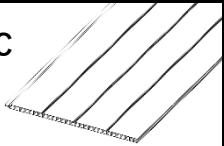
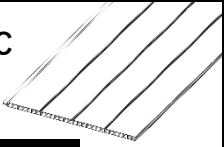
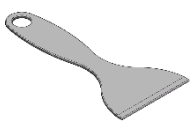
3PC	
WA-01	
3PC	
WA-03	
	
JTTY-D-01	

Step 13

4pc

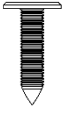

ST4.2*20

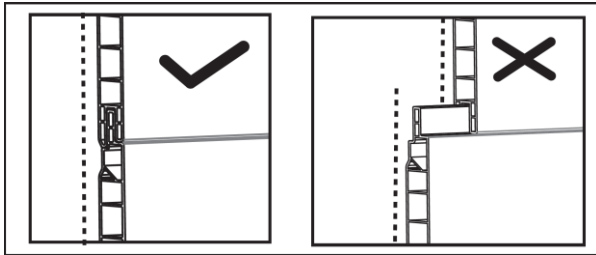
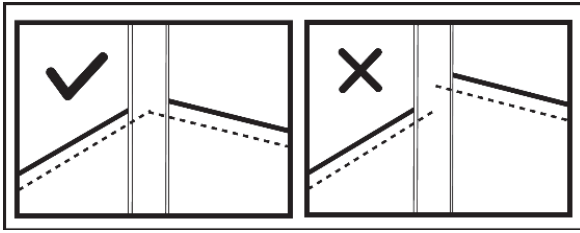

The panels must be aligned when they are installed

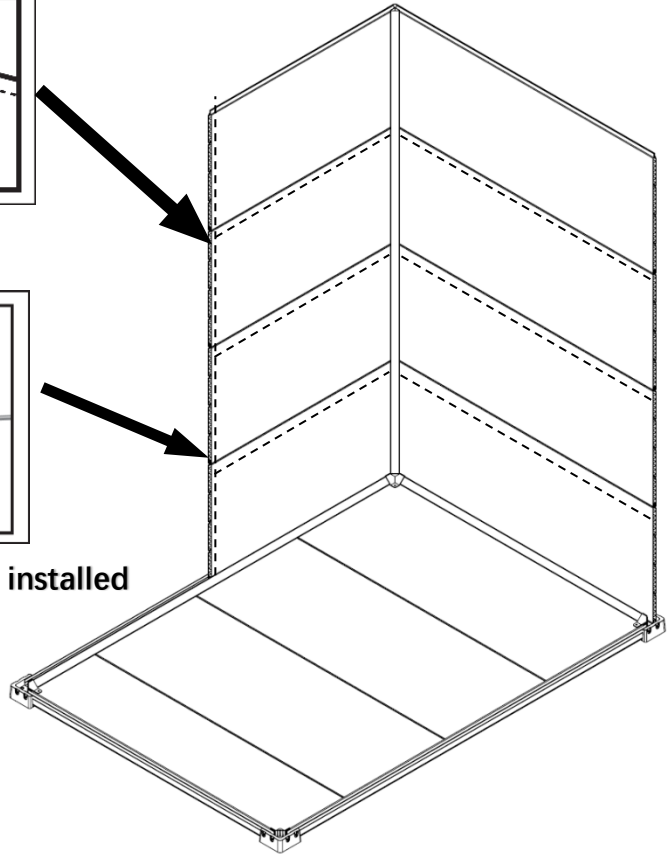

Step 14

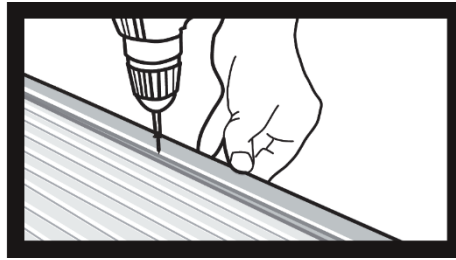

12pc



ST4.2*20

Fix the screws on the profile along the marking line

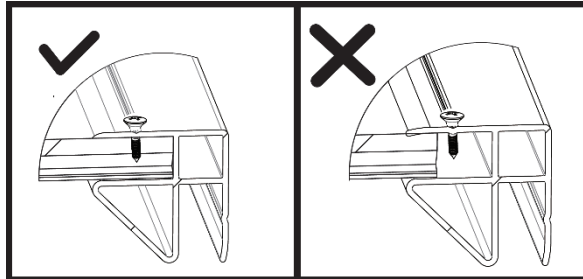

The sheet is fully inserted into the profile to fix the

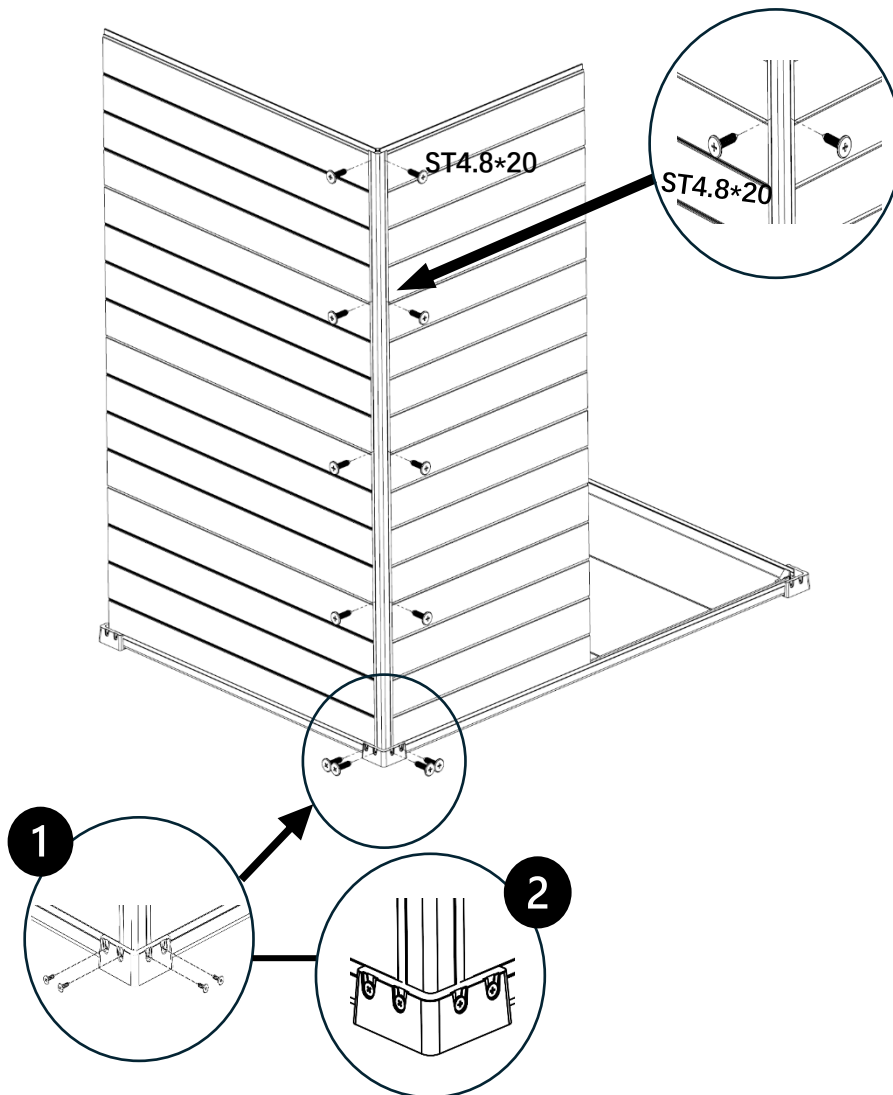

Step 15

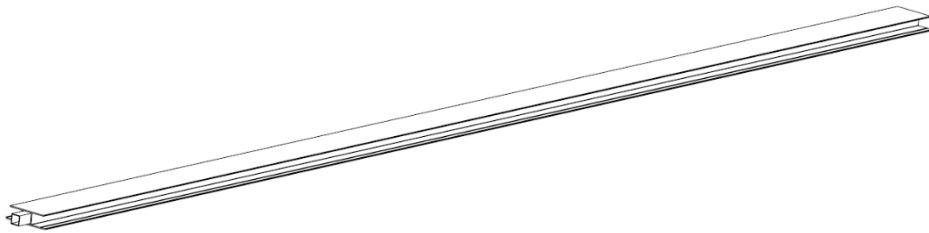
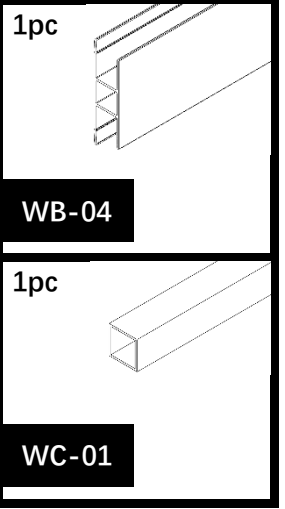
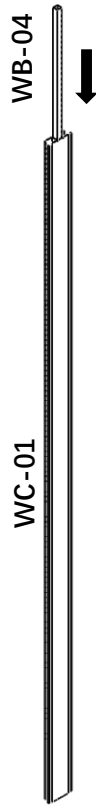

Step 16

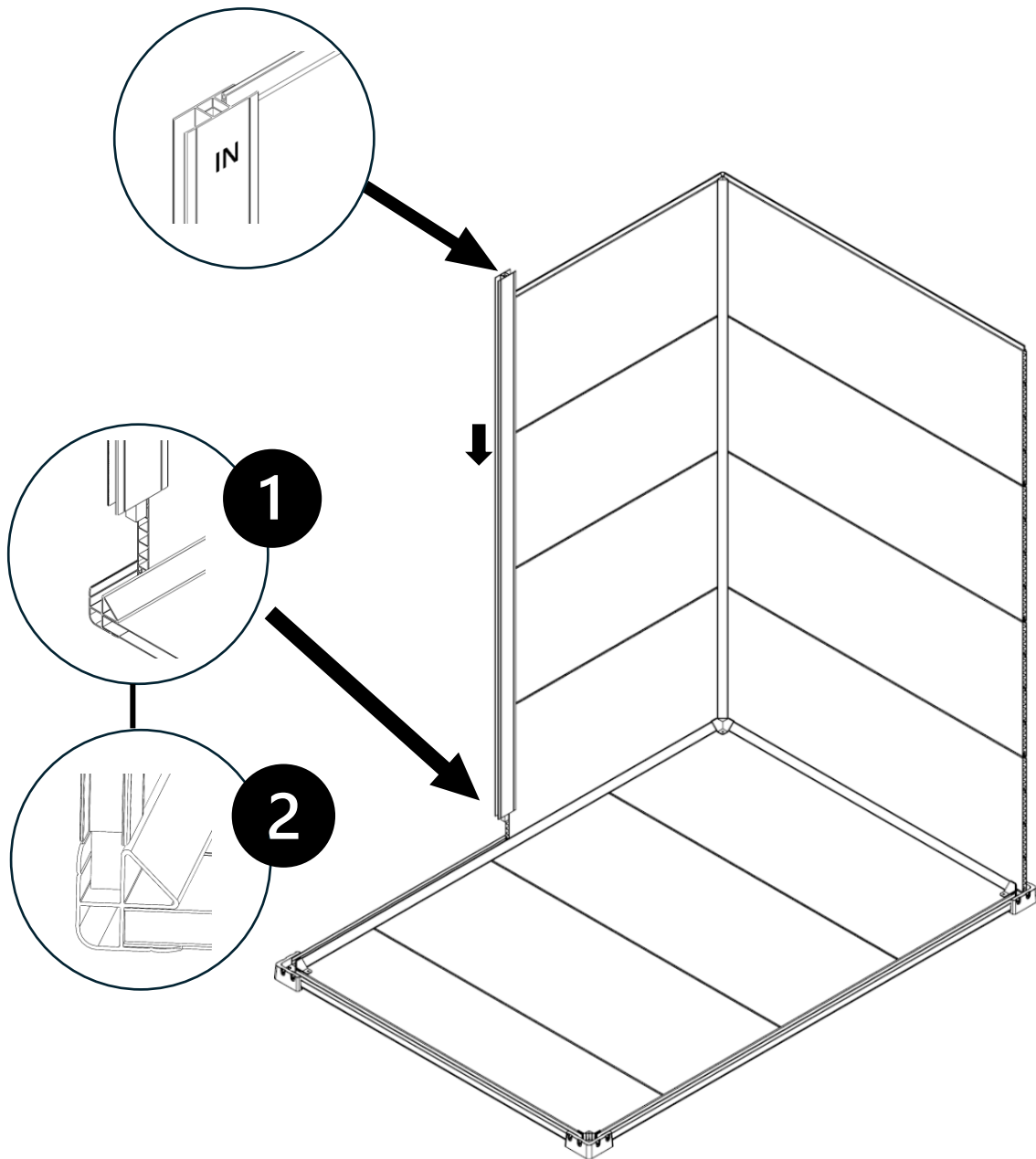
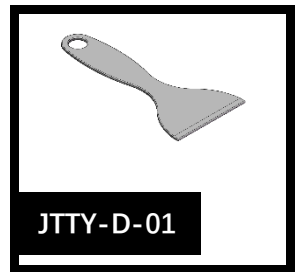
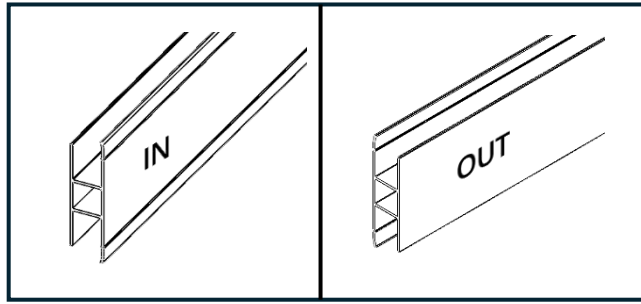

Step 17

4PC

WA-01

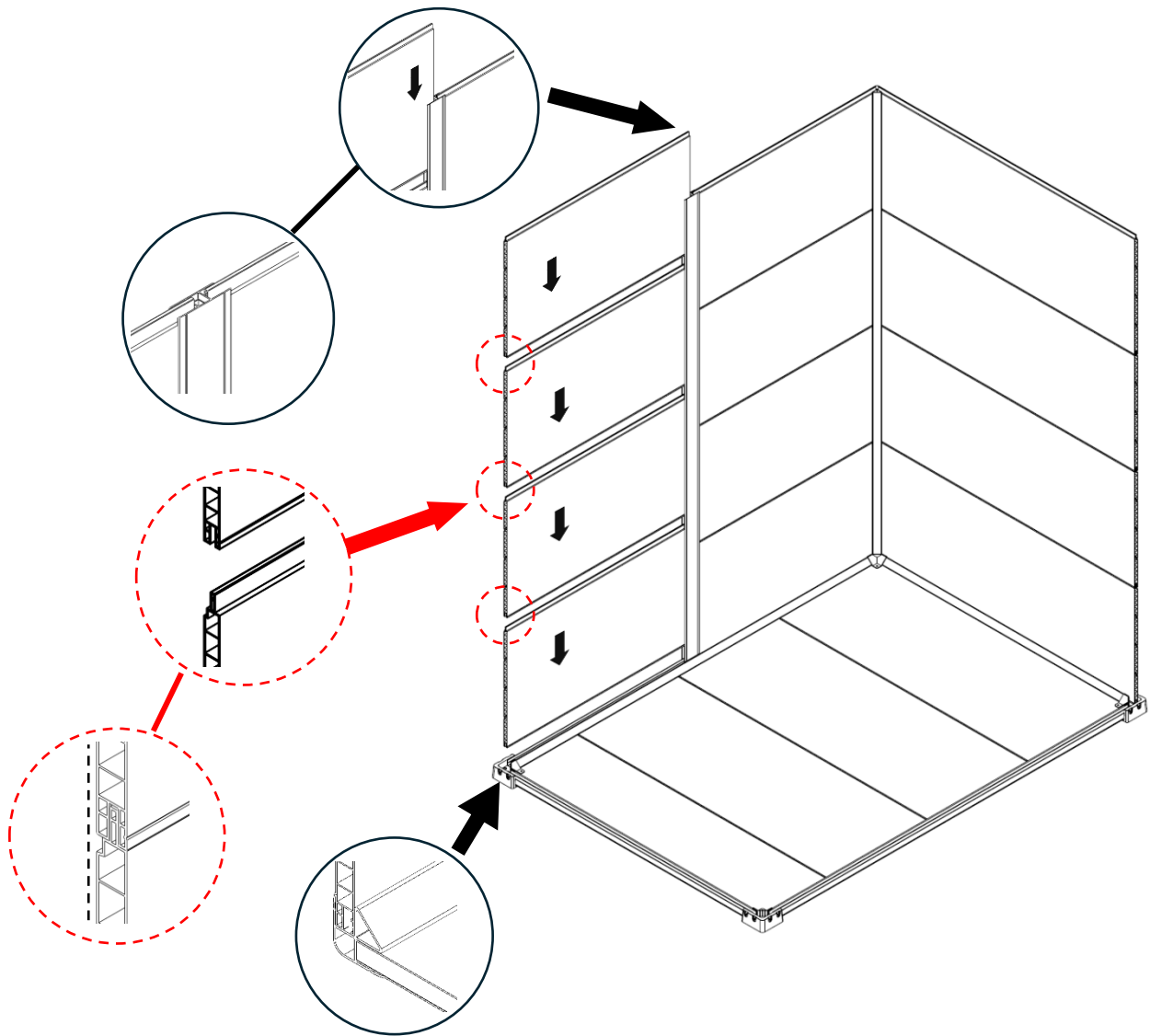

Step 18

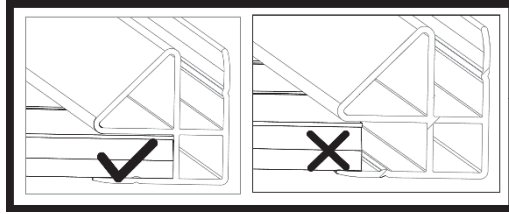

The panel fits perfectly inside the profile

1c

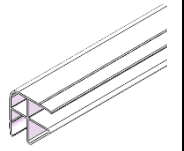

WB-01

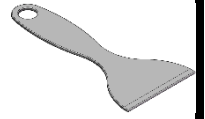

JTTY-D-01

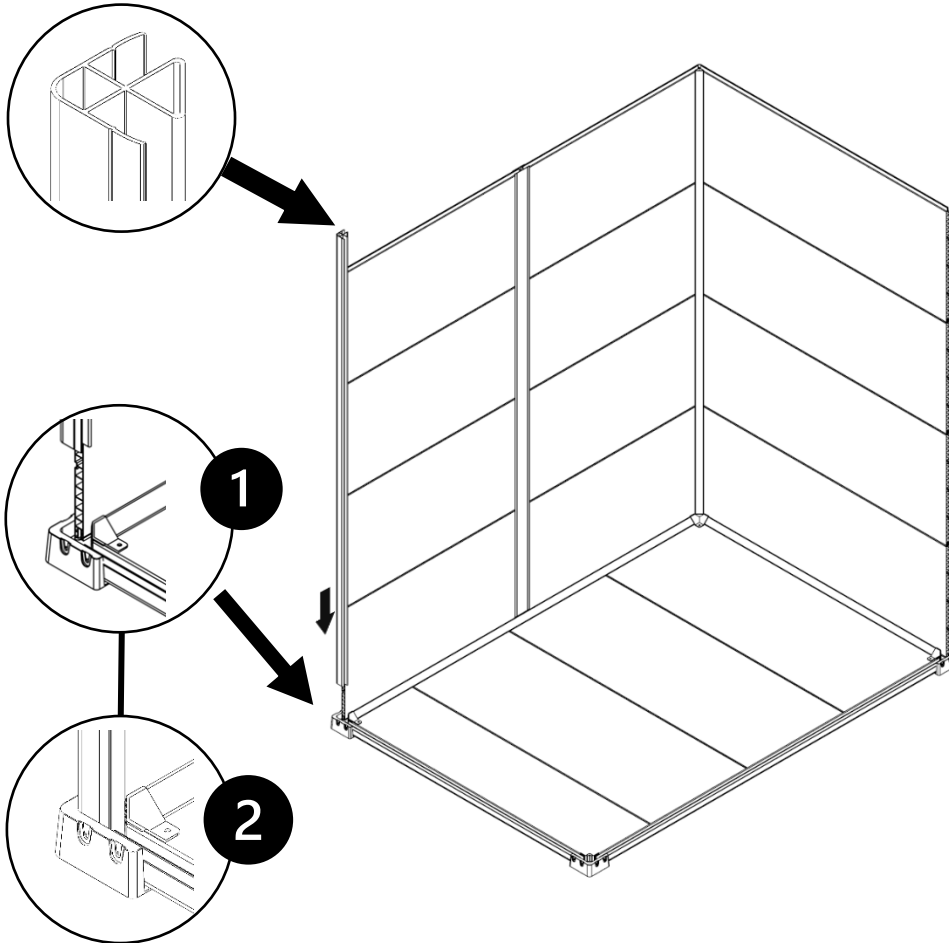

Step 19

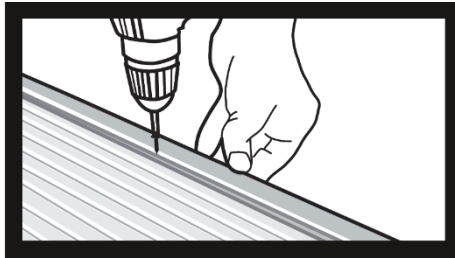

6PC



ST4.2*20

Fix the screws on the profile along the marking line

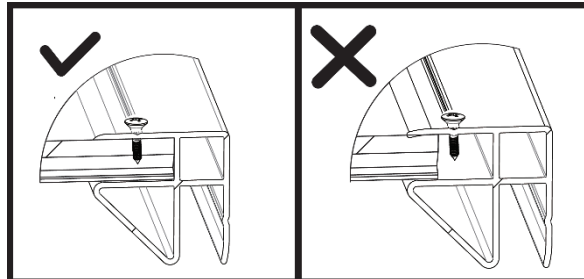

The sheet is fully inserted into the profile to fix the

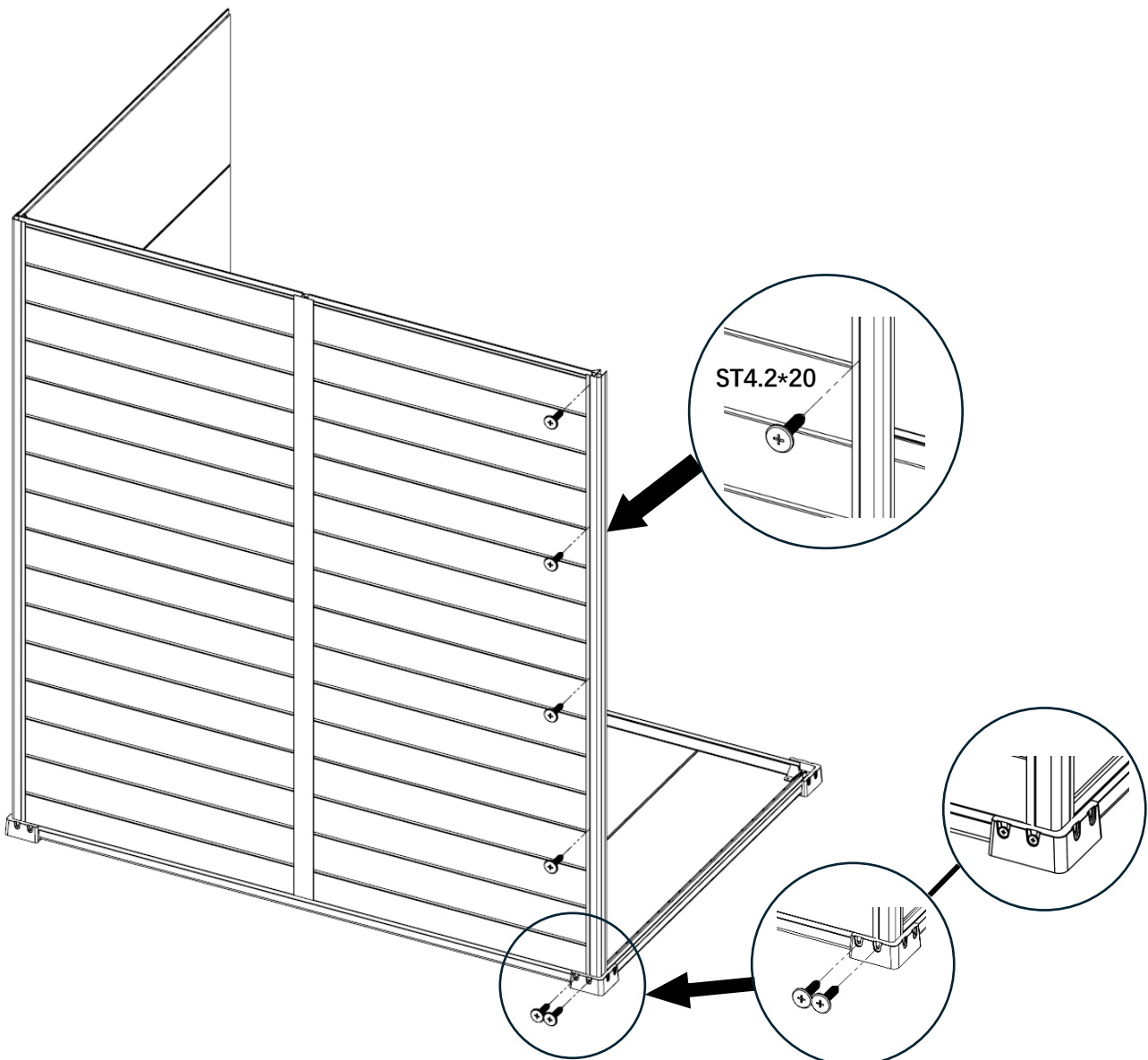

Step 20

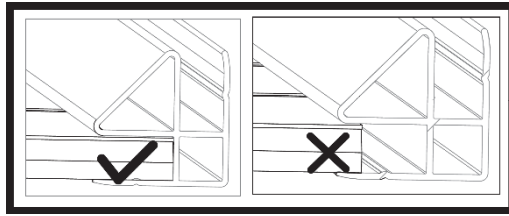

The panel fits perfectly inside the profile

1c

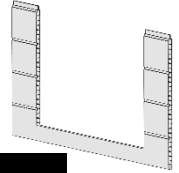

WA-06

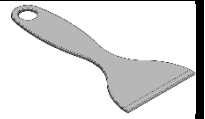

JTTY-D-01

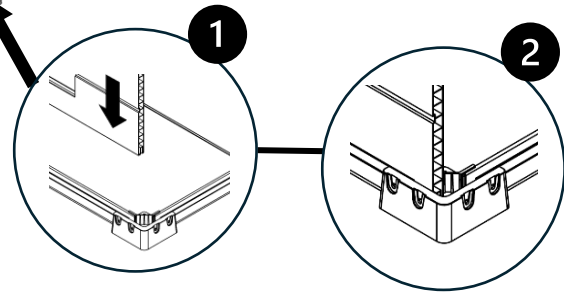
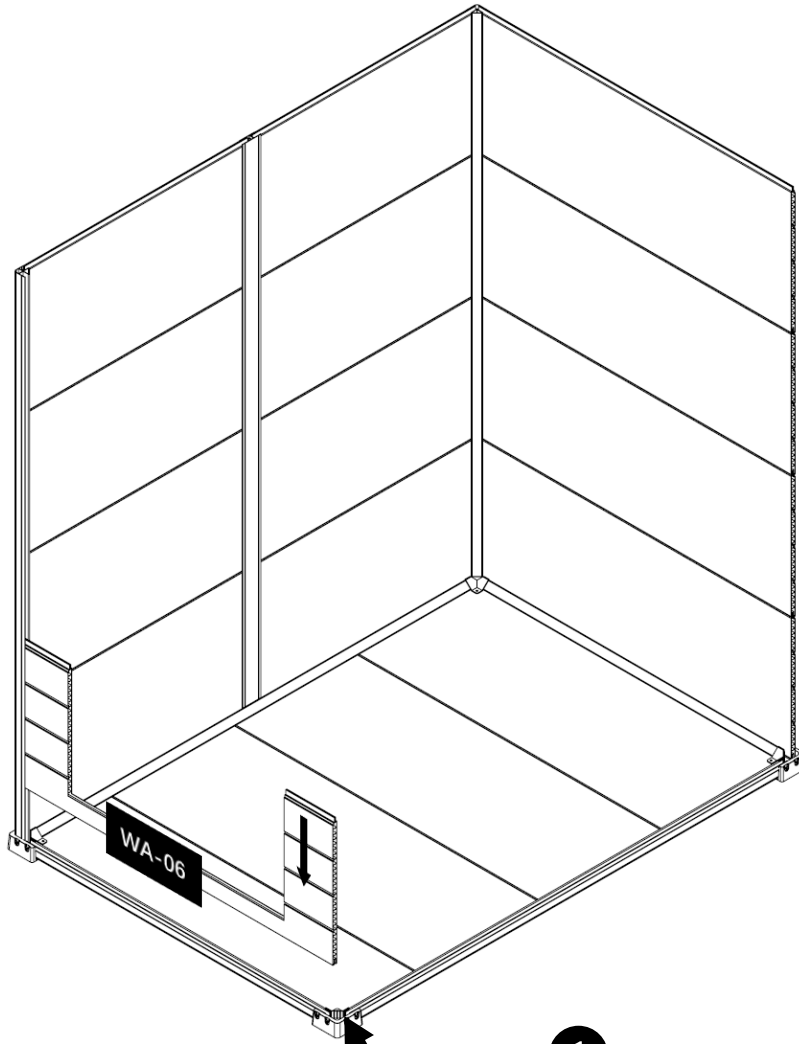

Step 21

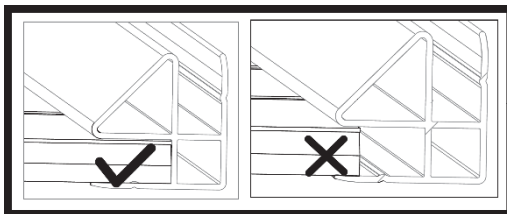

The panel fits perfectly inside the profile

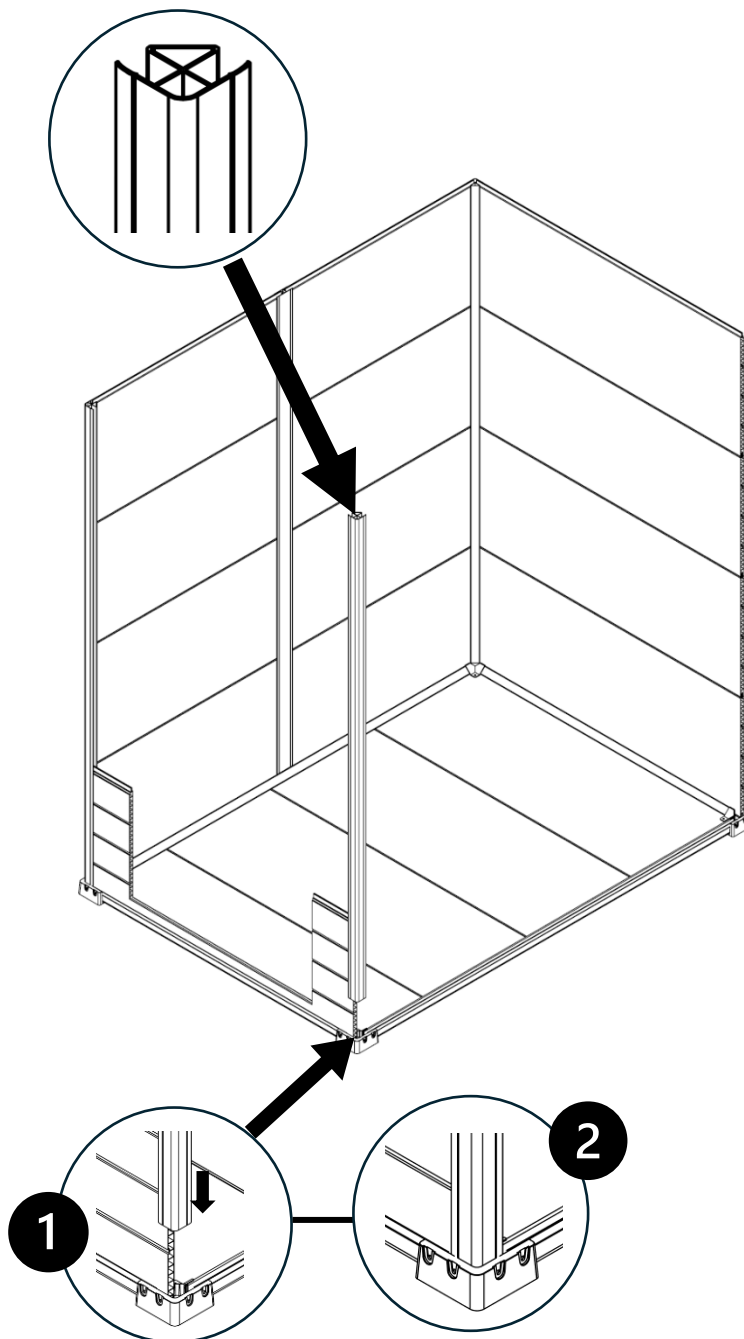

1c

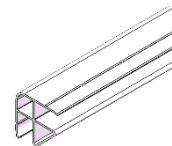

WB-01

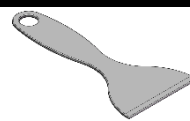

JTTY-D-01

Step 22

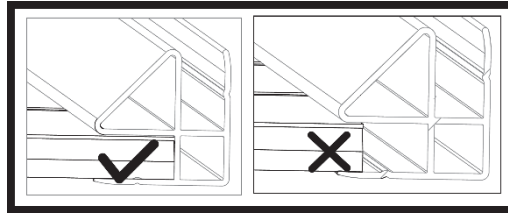

The panel fits perfectly inside the profile

4c

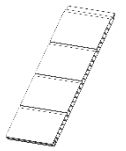

WA-09

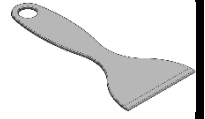

JTTY-D-01

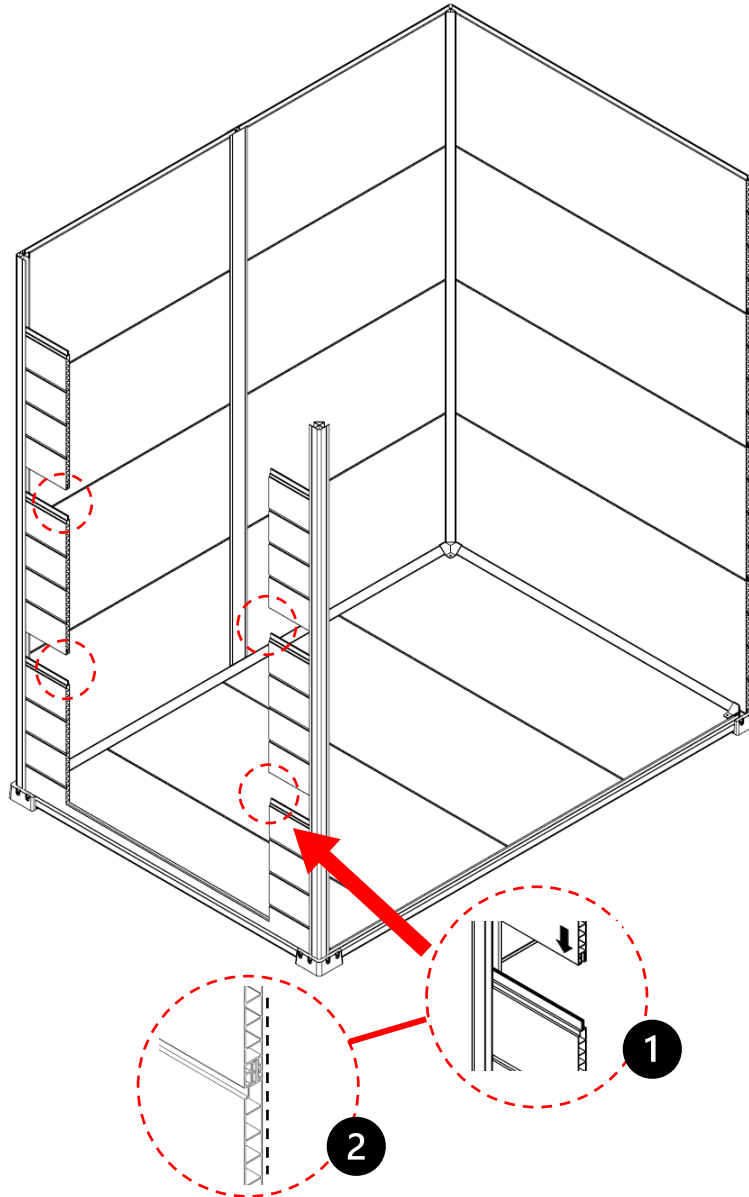

Step 23

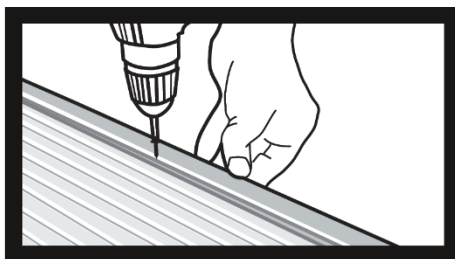

8PC



ST4.2*20

Fix the screws on the profile along the marking line

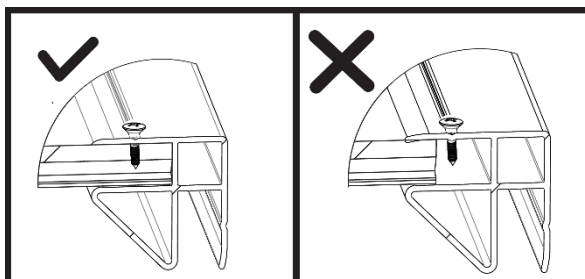

The sheet is fully inserted into the profile to fix the

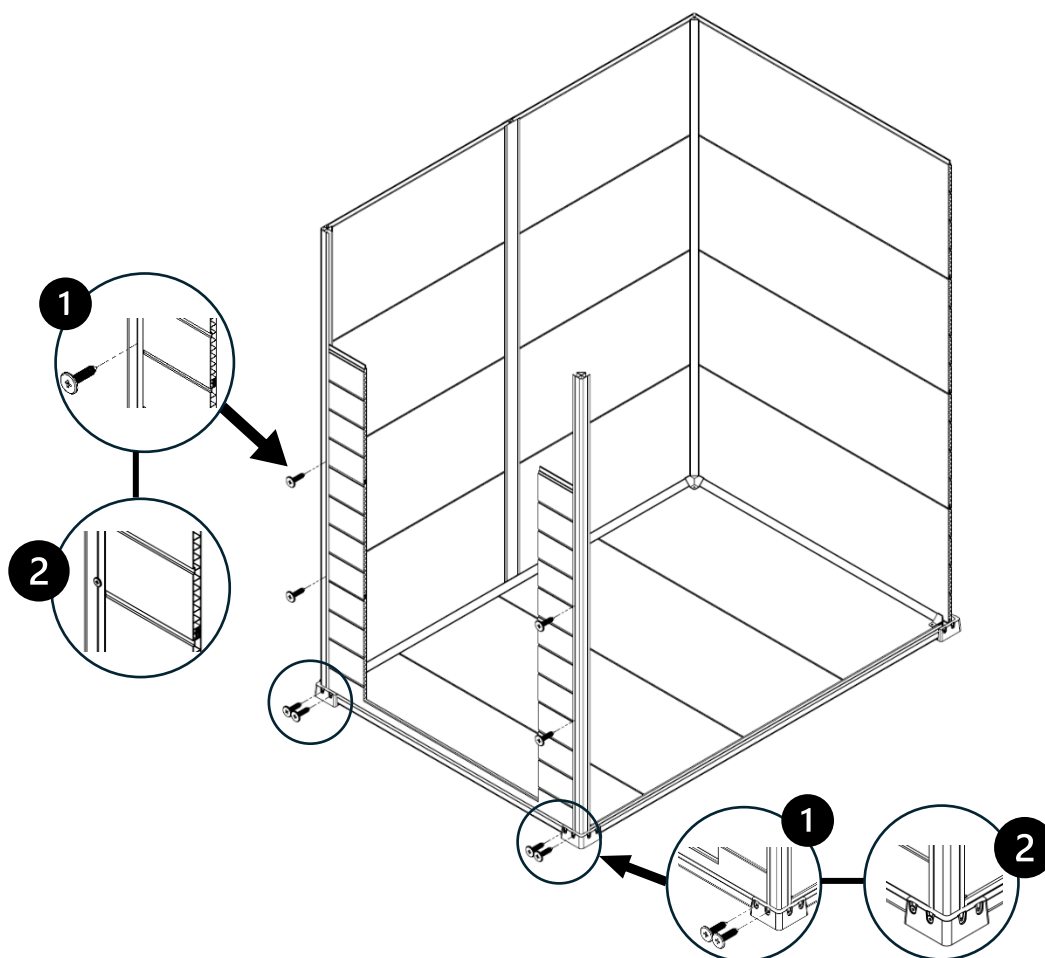

*

Step 24

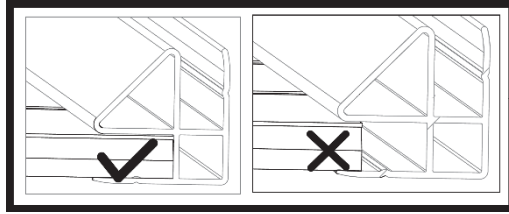

The panel fits perfectly inside the profile

4PC



WA-01

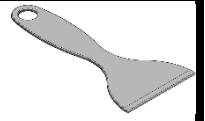

JTTY-D-01

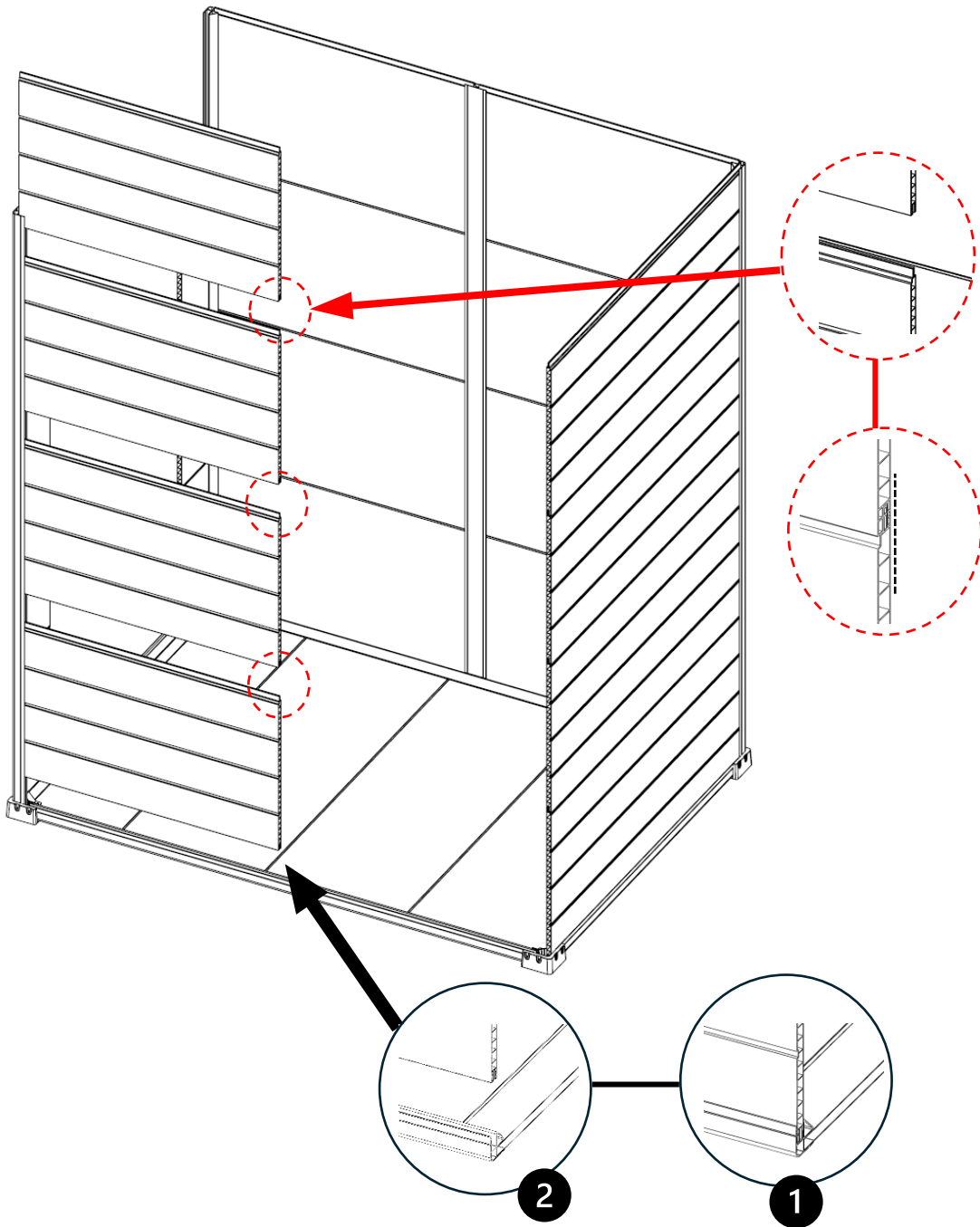

Step 25

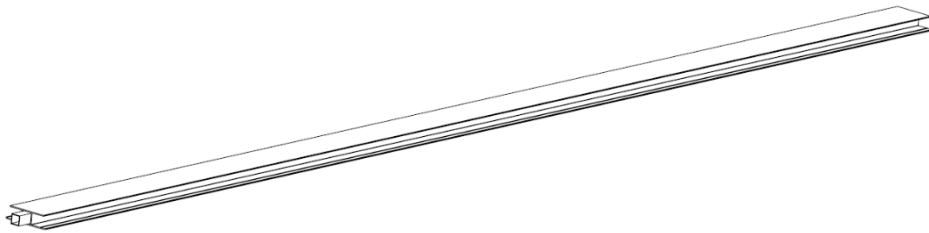
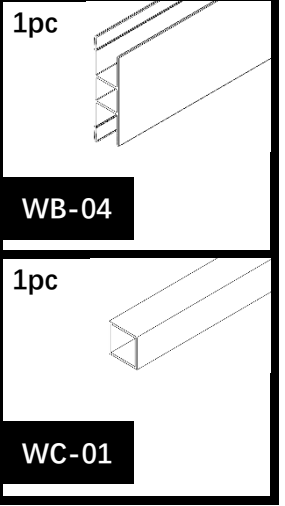
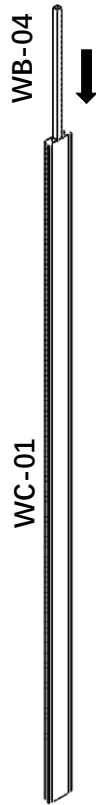

Step 26

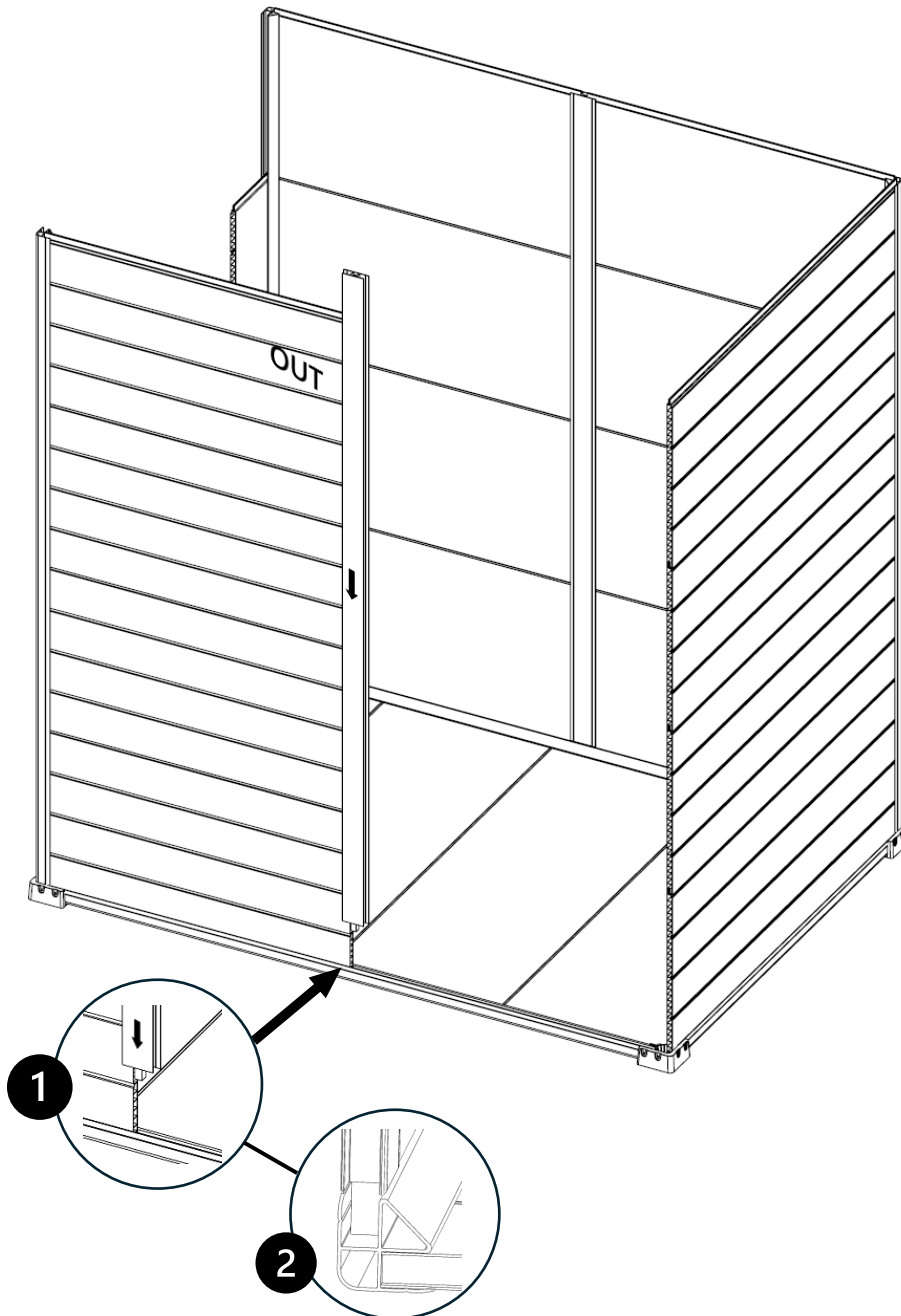
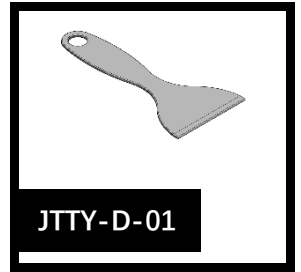
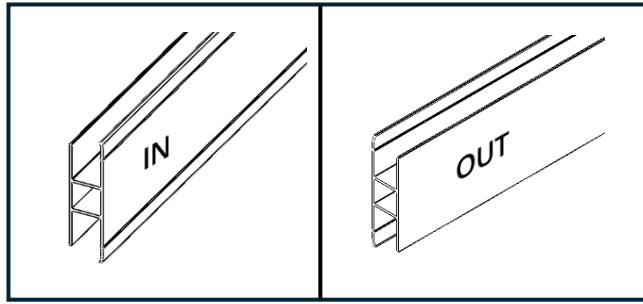

Step 27

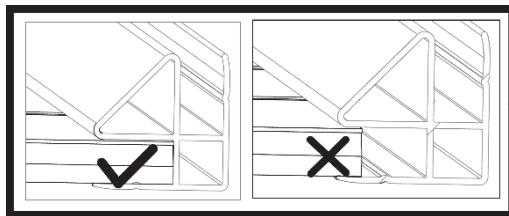

The panel fits perfectly inside the profile

1c

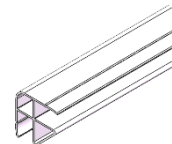

WB-01

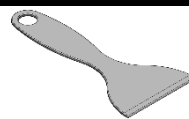

JTTY-D-01

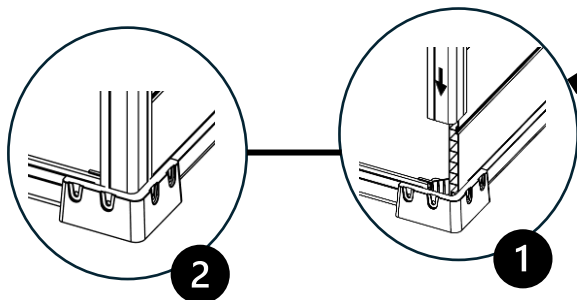
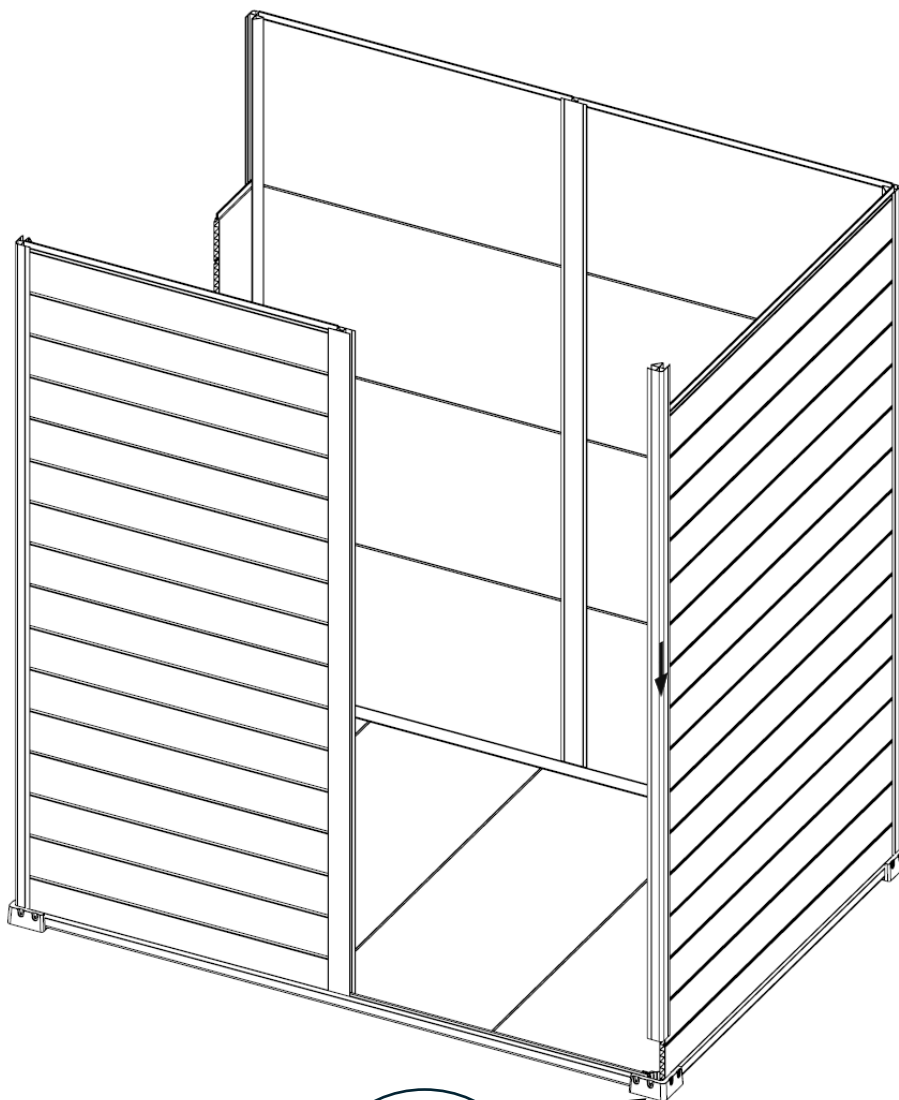

Step 28

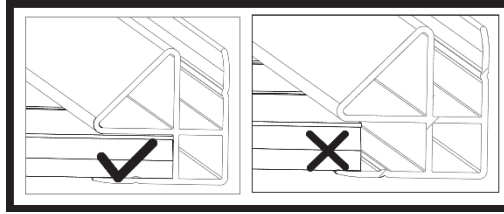

The panel fits perfectly inside the profile

3PC



WA-01

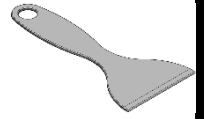

JTTY-D-01

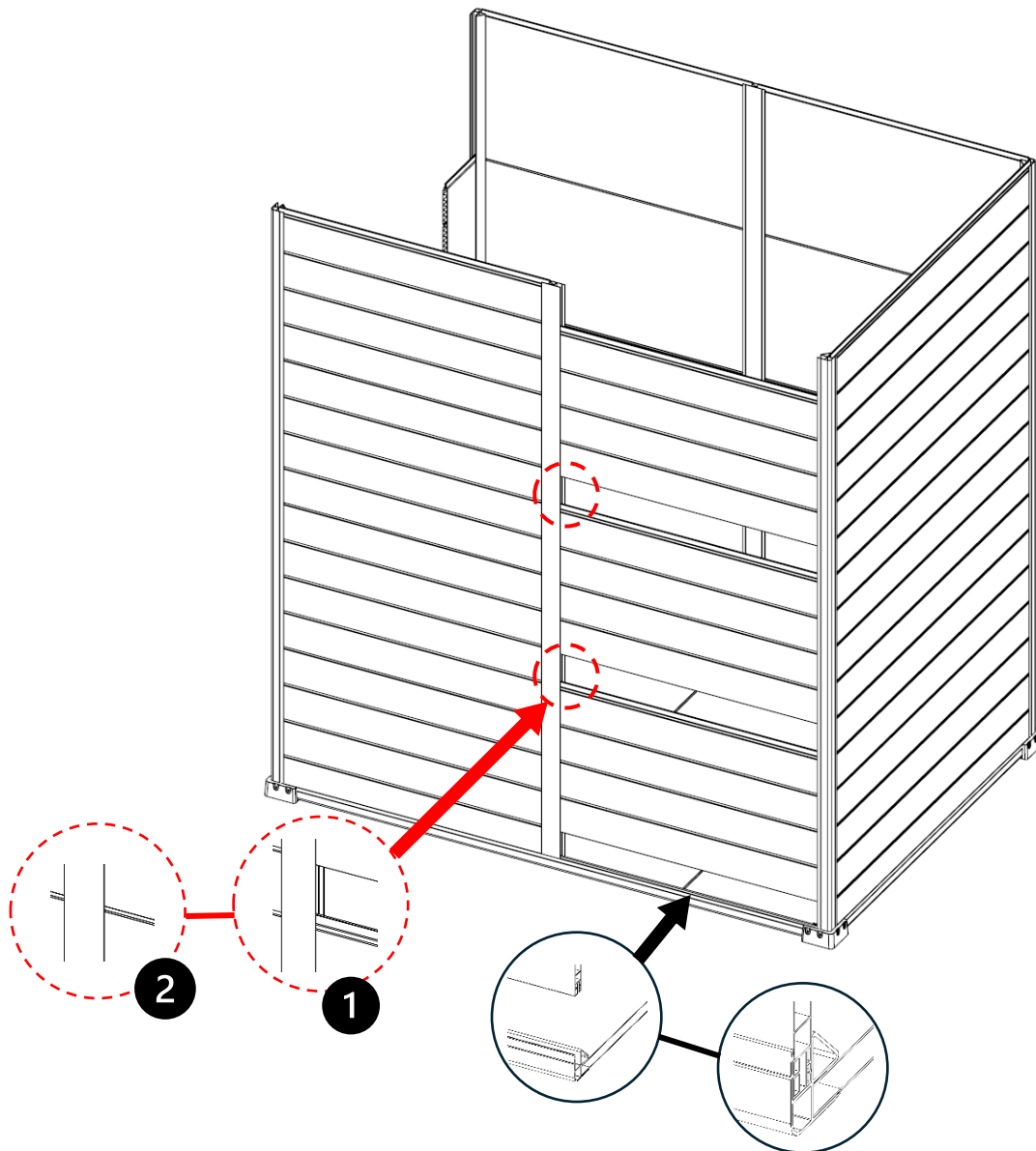

Step 29

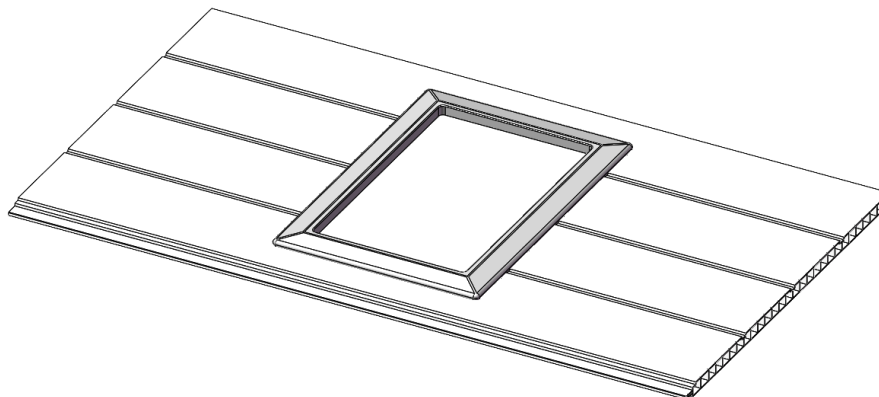
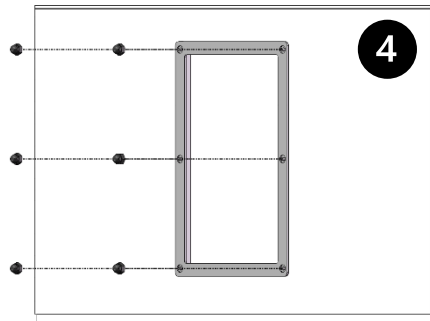
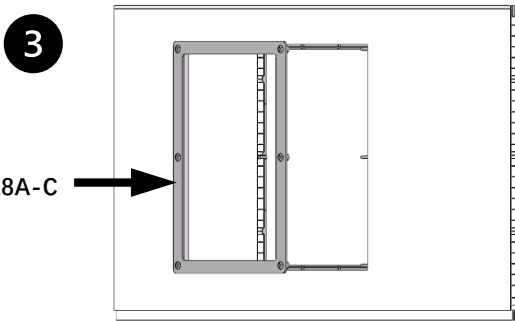
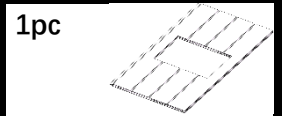
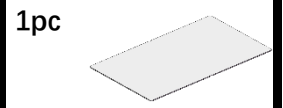
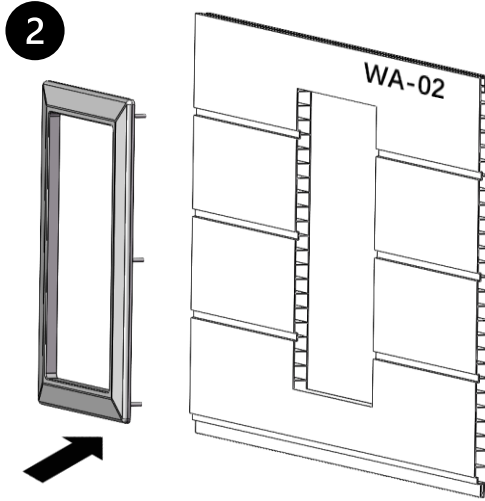
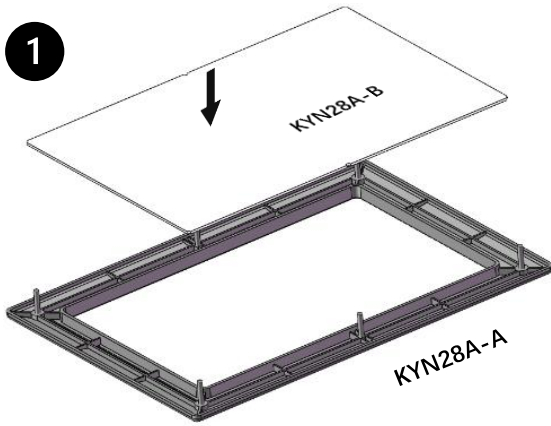

Step 30

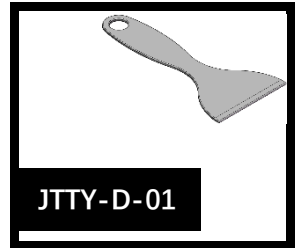
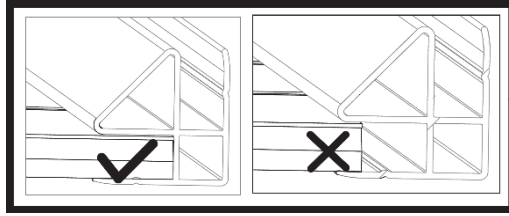

The panel fits perfectly inside the profile

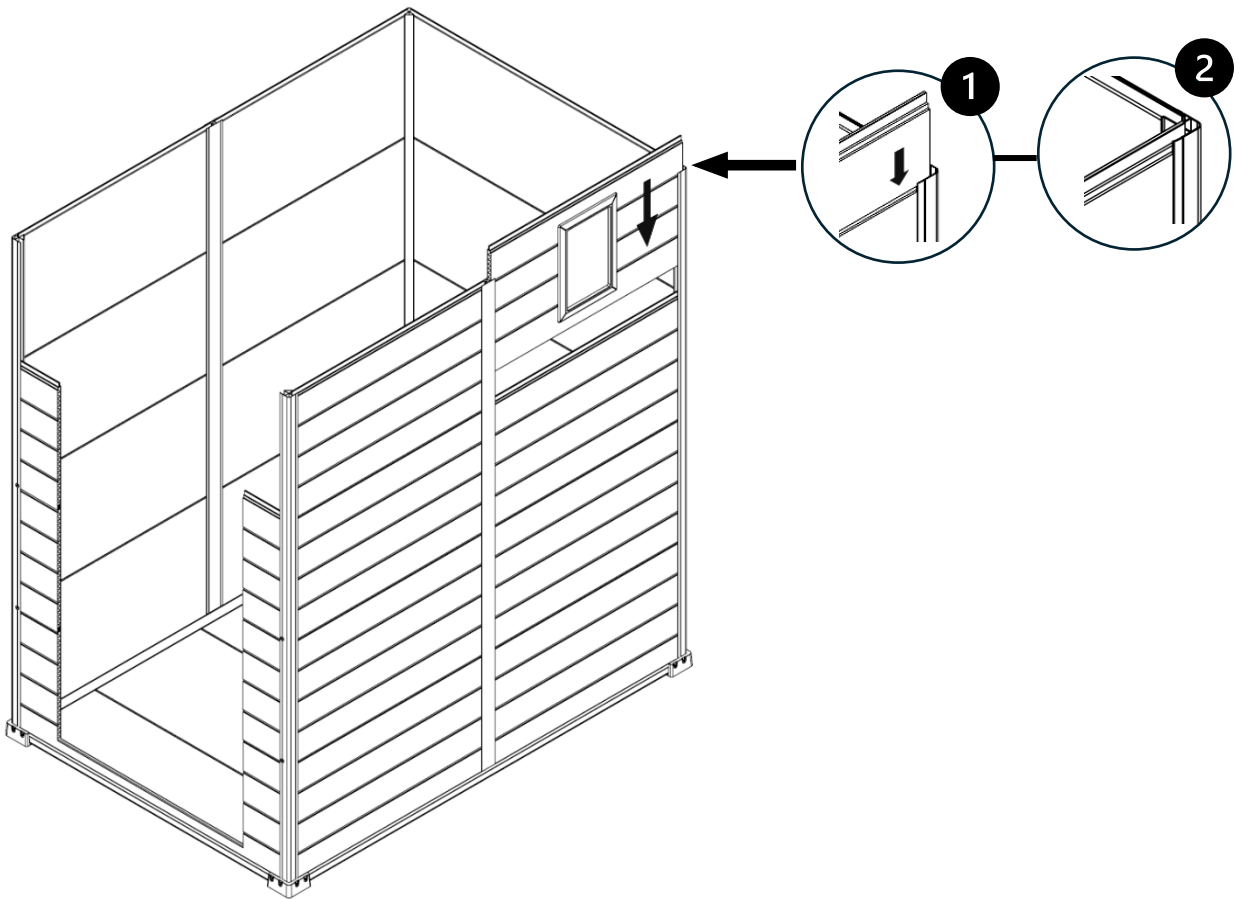

Step 31

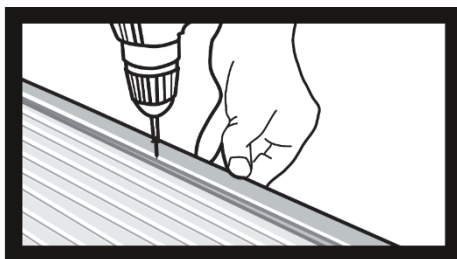

6pc



ST4.2*20

Fix the screws on the profile along the marking line

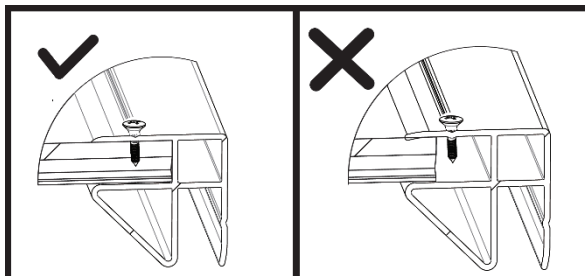

The sheet is fully inserted into the profile to fix the

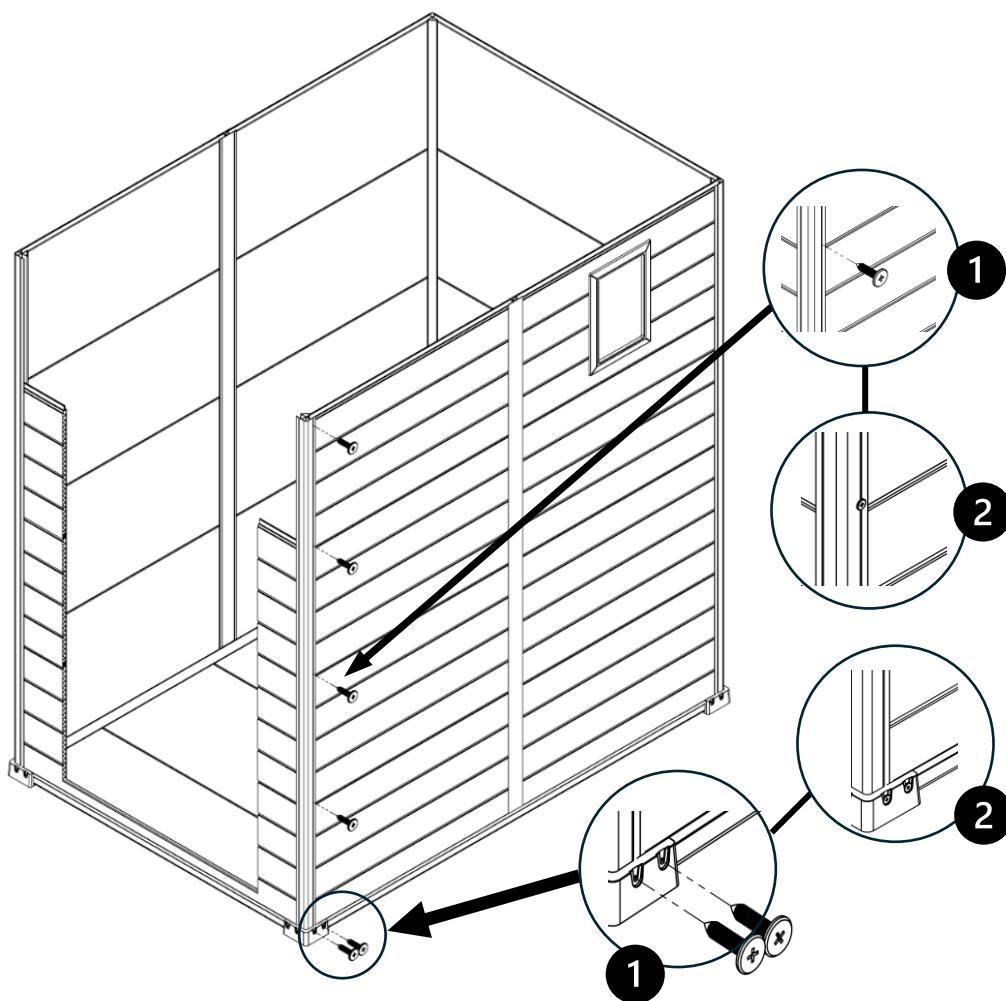

Step 32

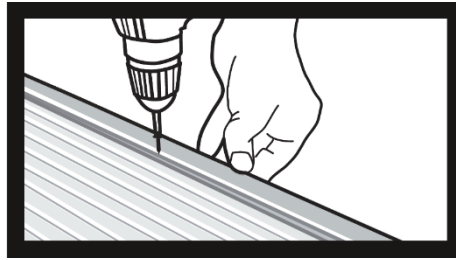

12pc



ST4.2*20

Fix the screws on the profile along the marking line

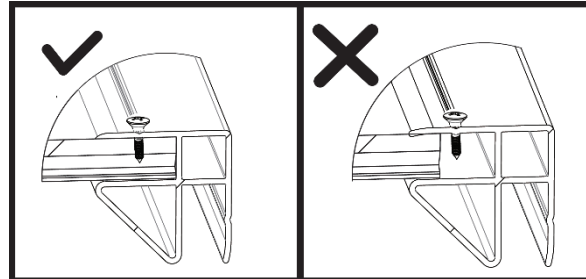

The sheet is fully inserted into the profile to fix the

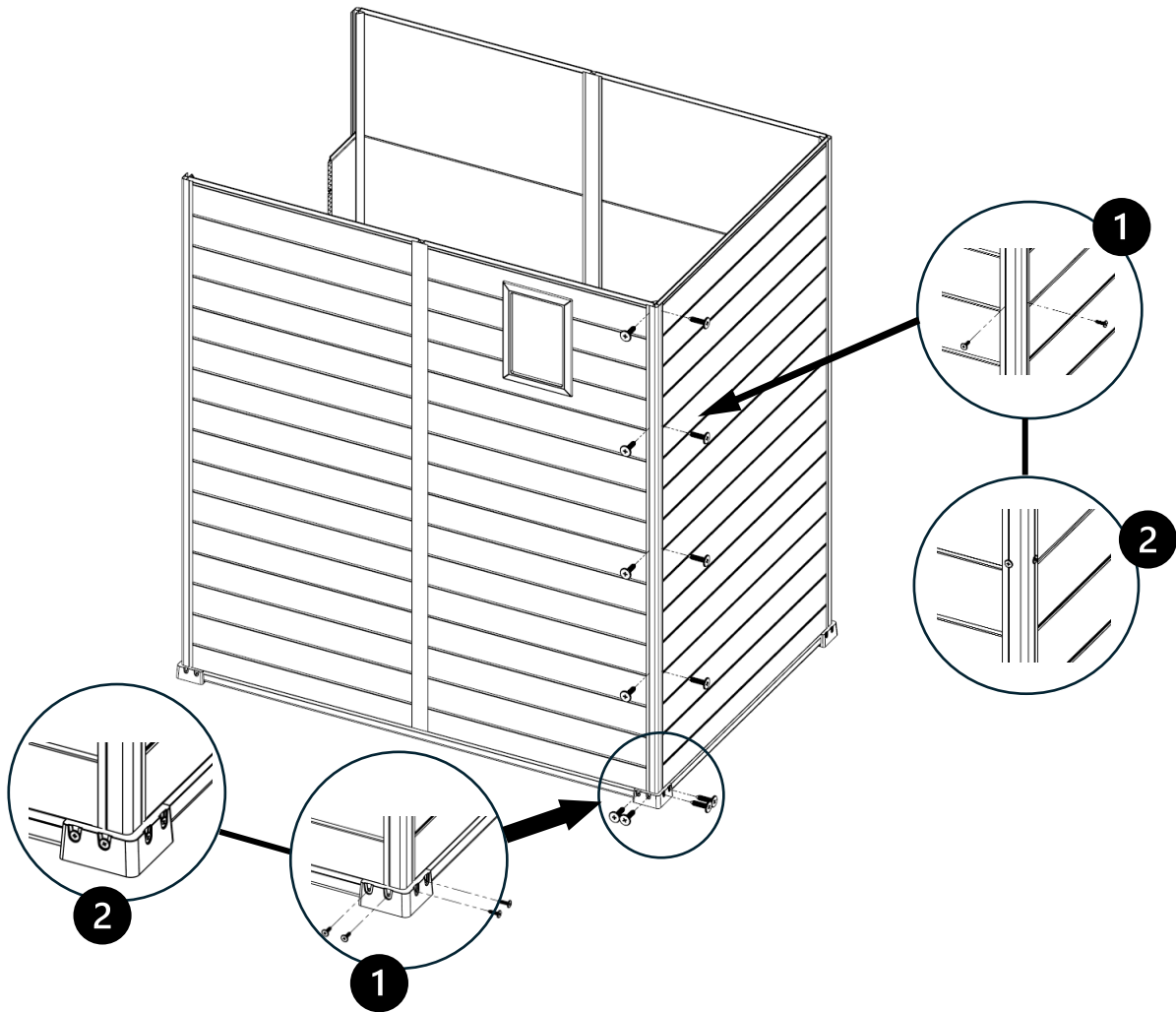

Step 33

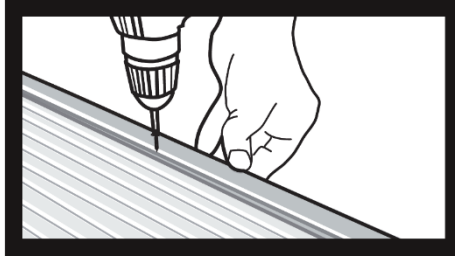

Fix the screws on the profile along the marking line

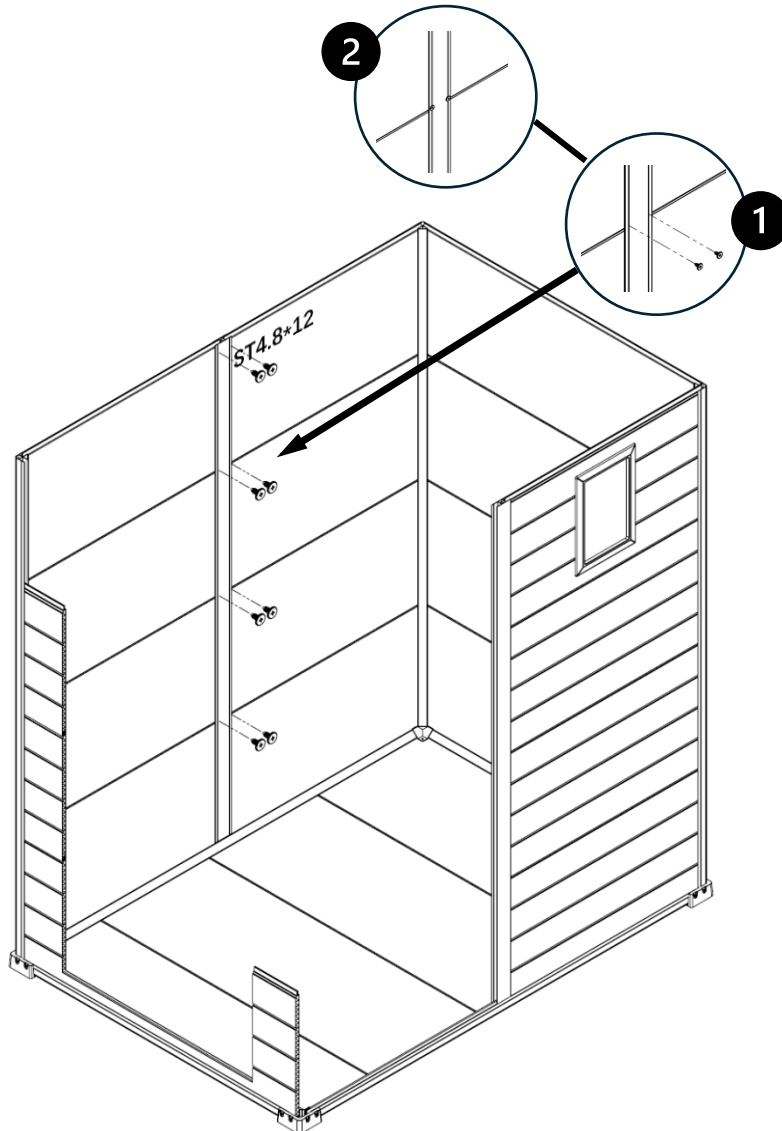

Step 34

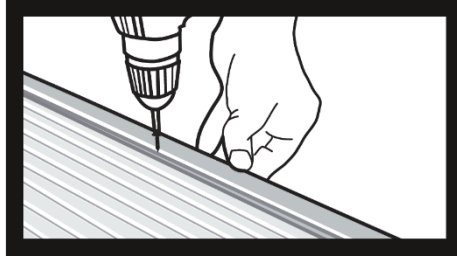

8pc



ST4.2*12

Fix the screws on the profile along the marking line

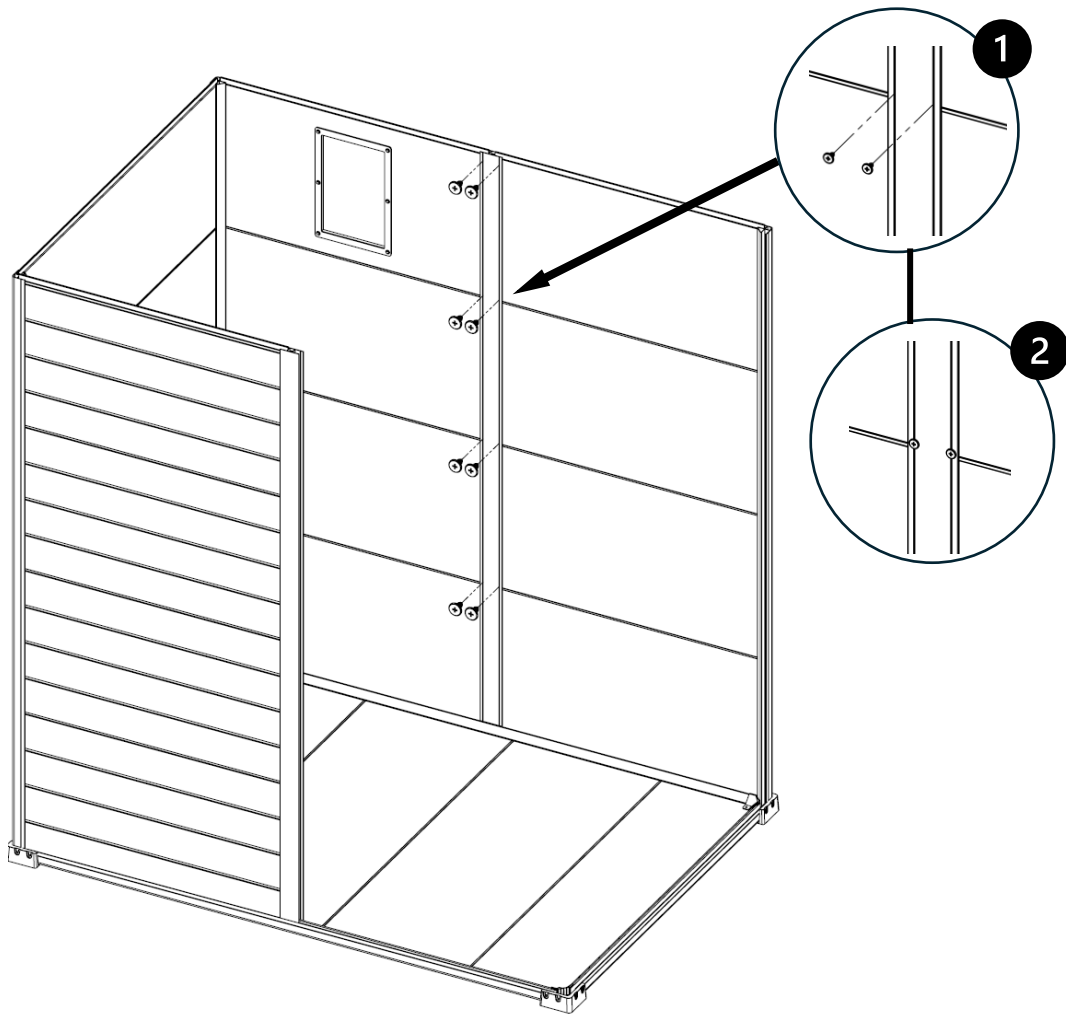

Step 35

1pc

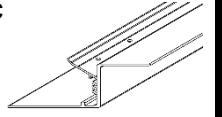

JTMK-WC-02

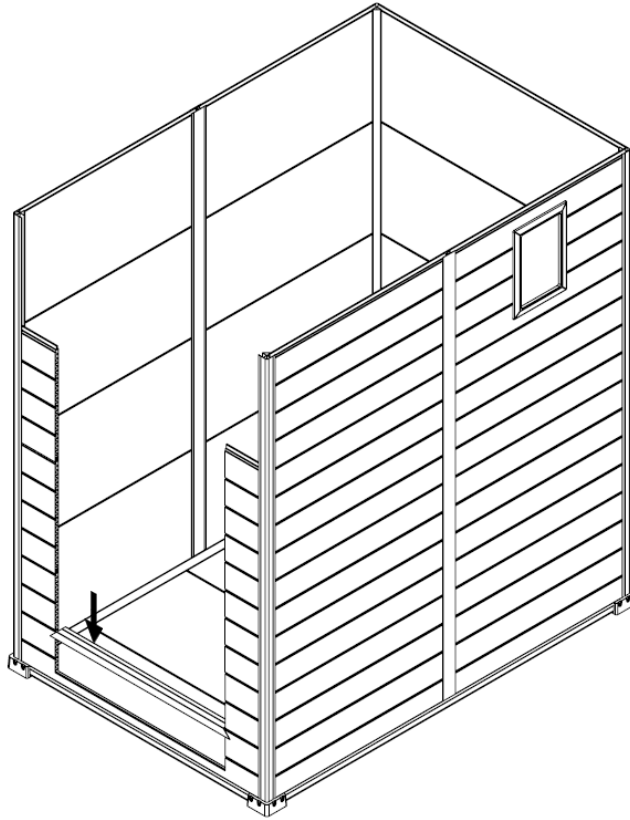

Step 36

1pc

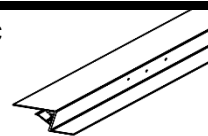

JTMK-WC-01

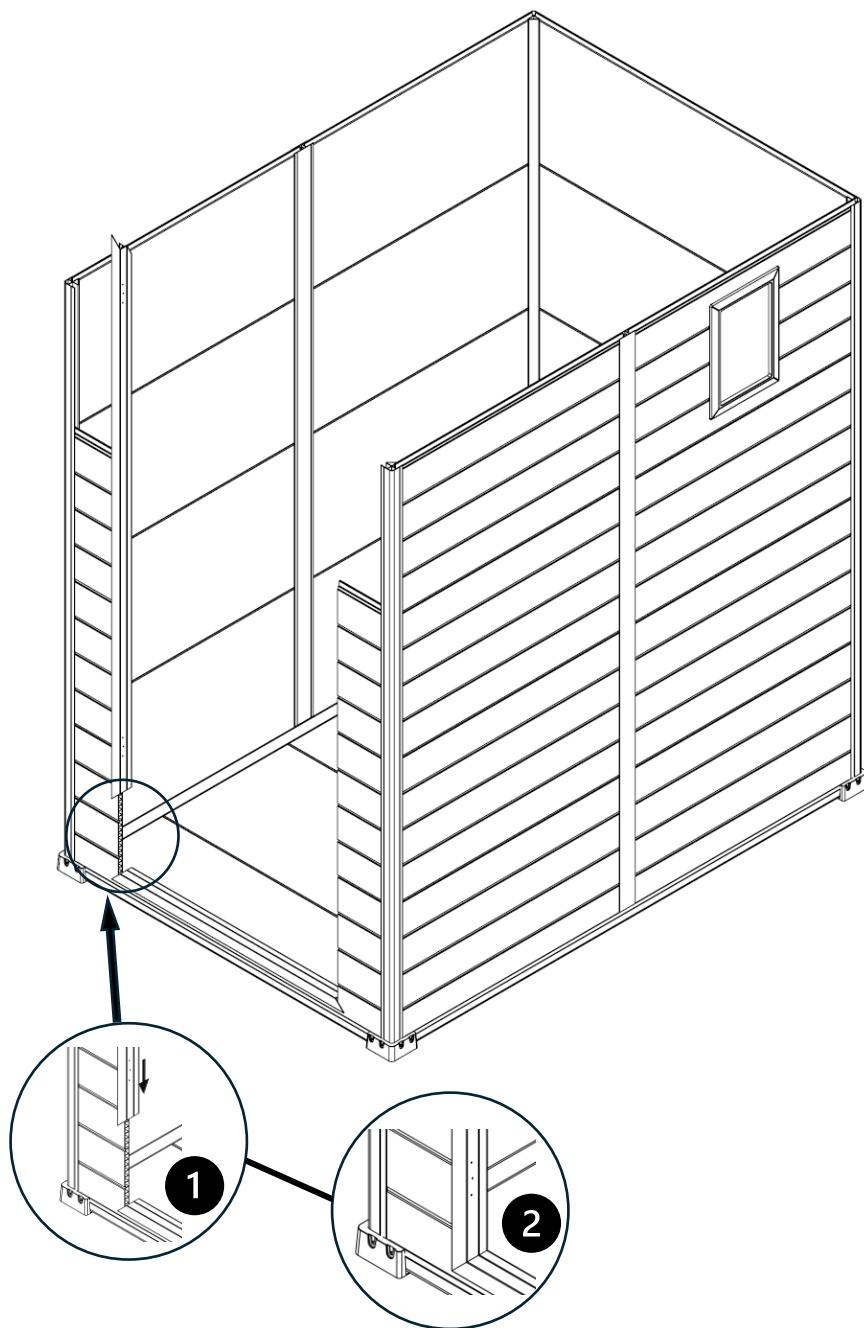

Step 37

1pc

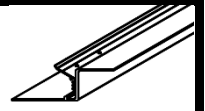

JTMK-WC-03

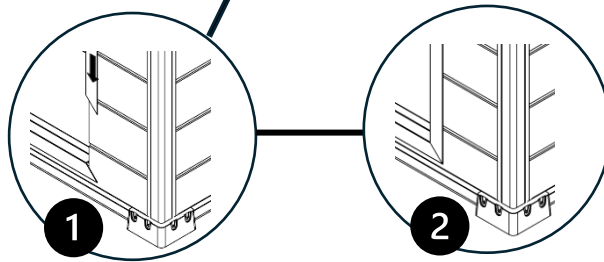
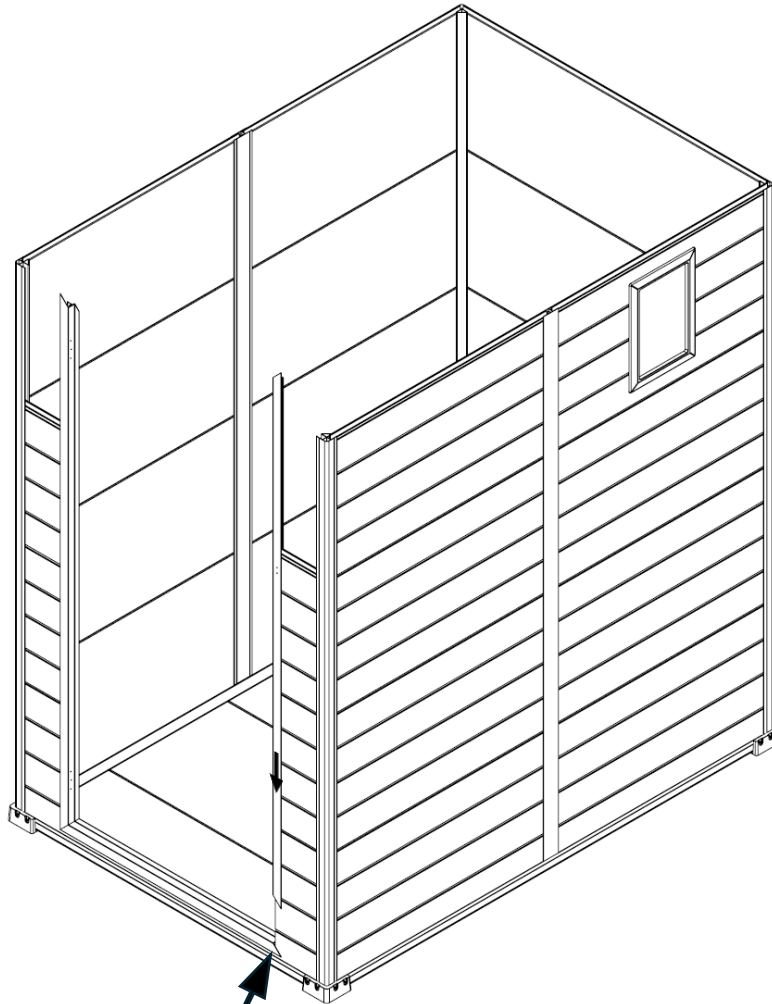

Step 38

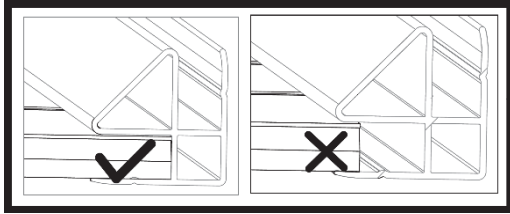
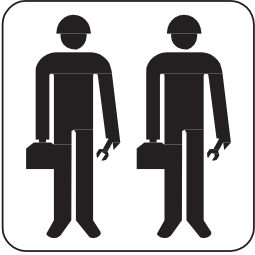

The panel fits perfectly inside the profile

1PC	
JTMK-WC-02	
1PC	
WA-04	
JTTY-D-01	

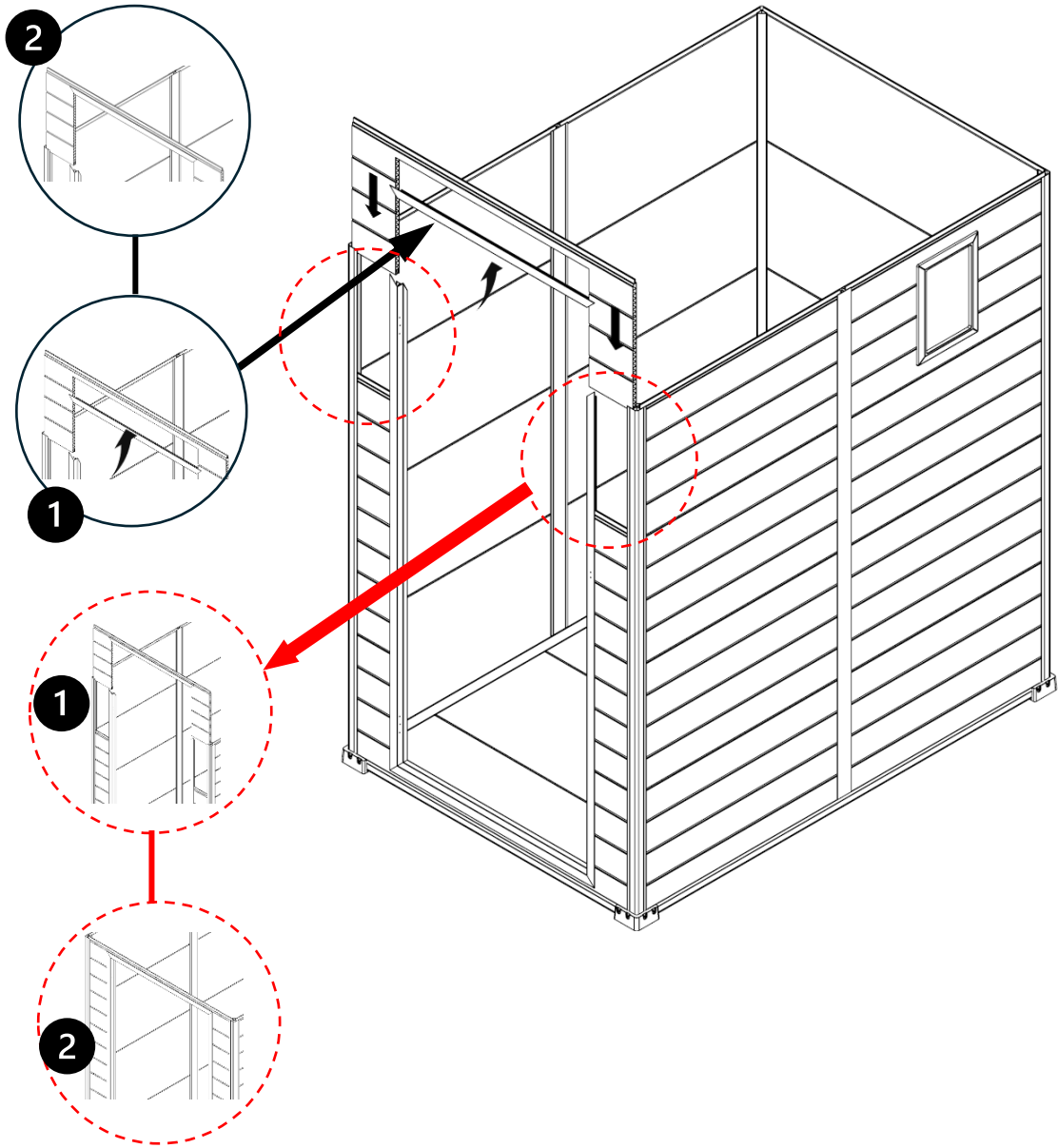

Step 39

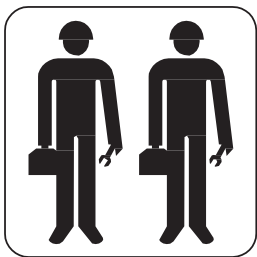

$AB=CD$

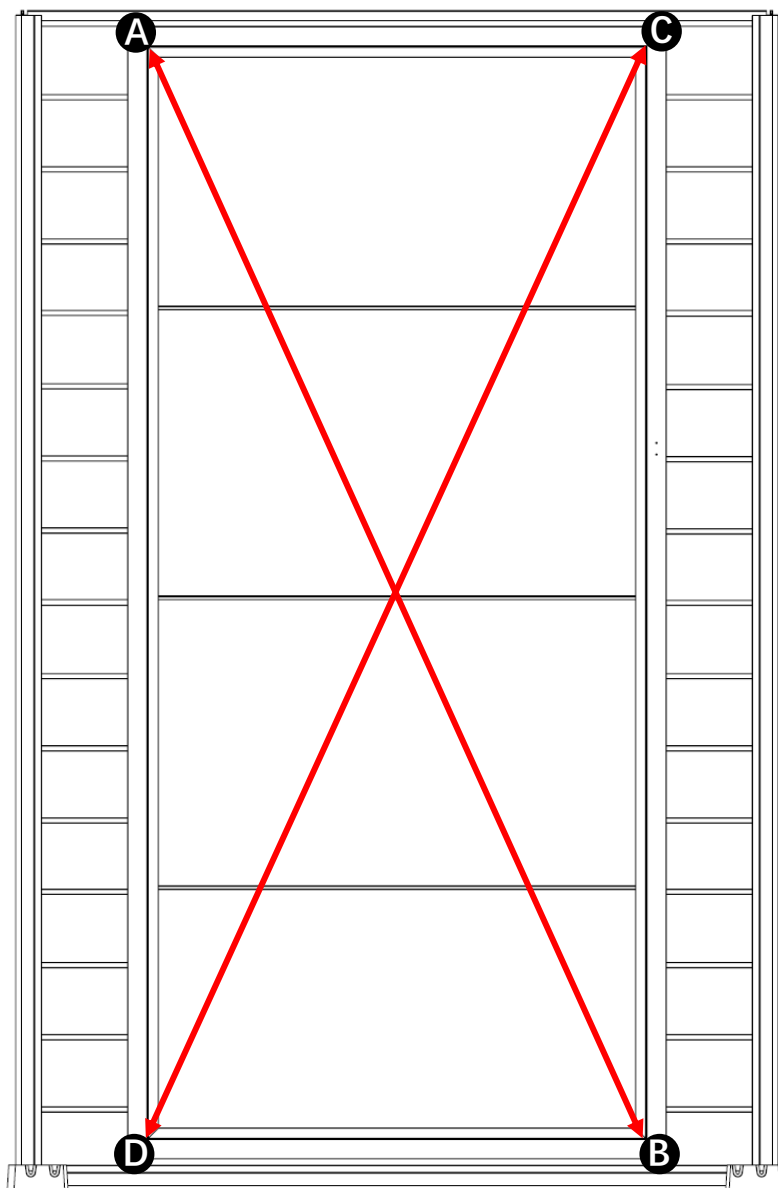

Step 40

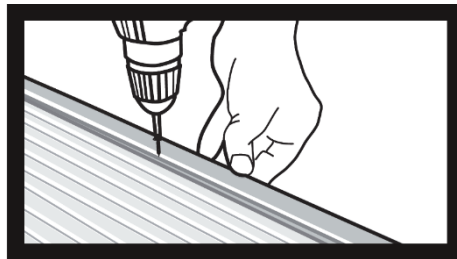

2PC



ST4.8*20

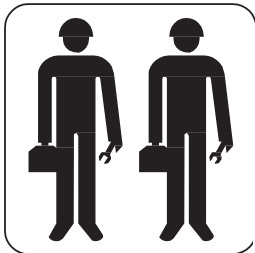

Fix the screws on the profile along the marking line

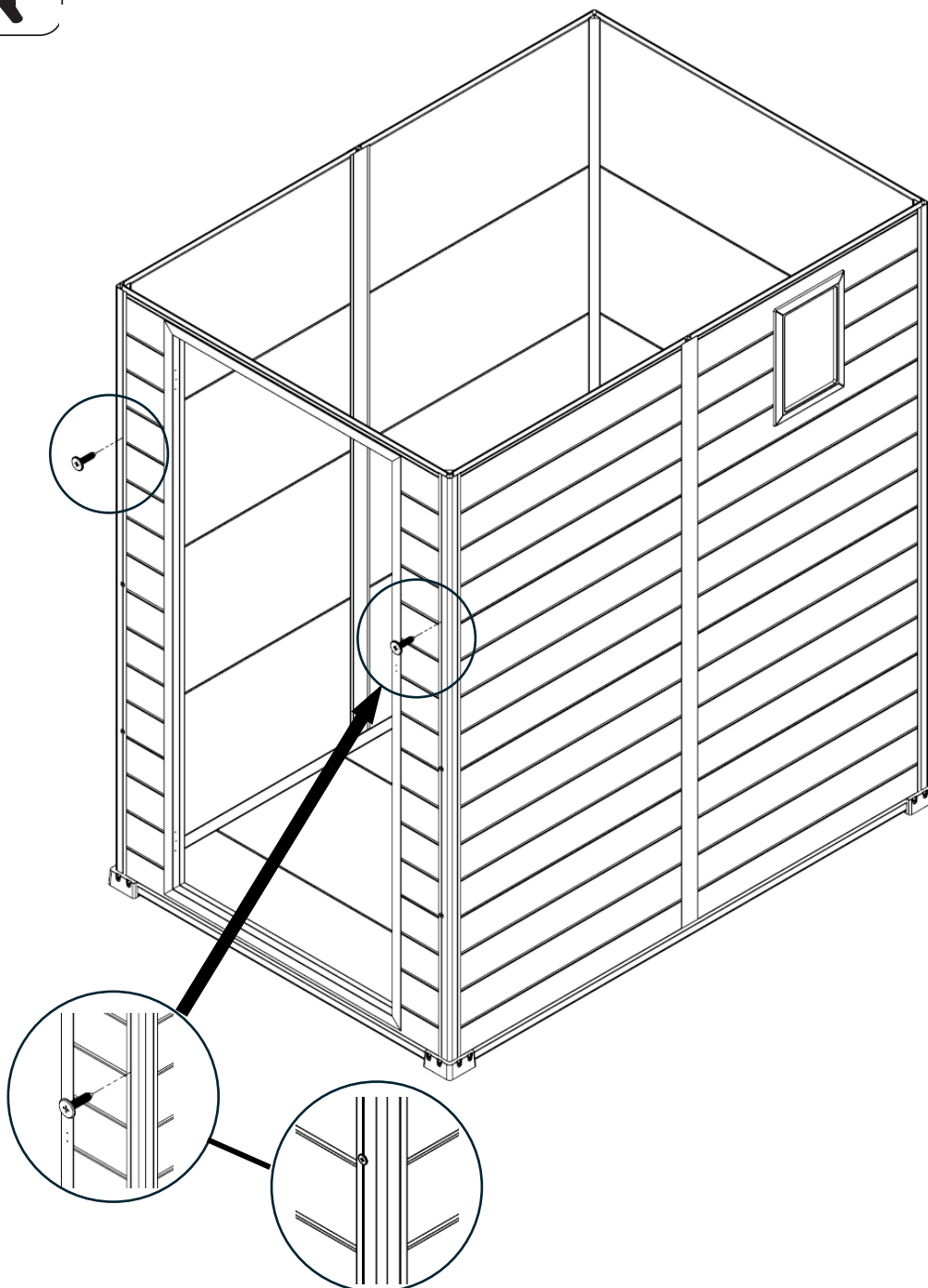

Step 41

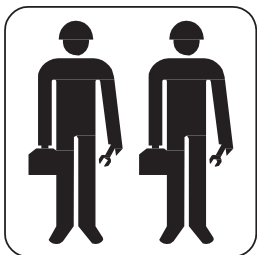

16PC

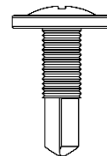

STYW4.2*12

4PC

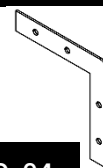

JTMK-WC-04

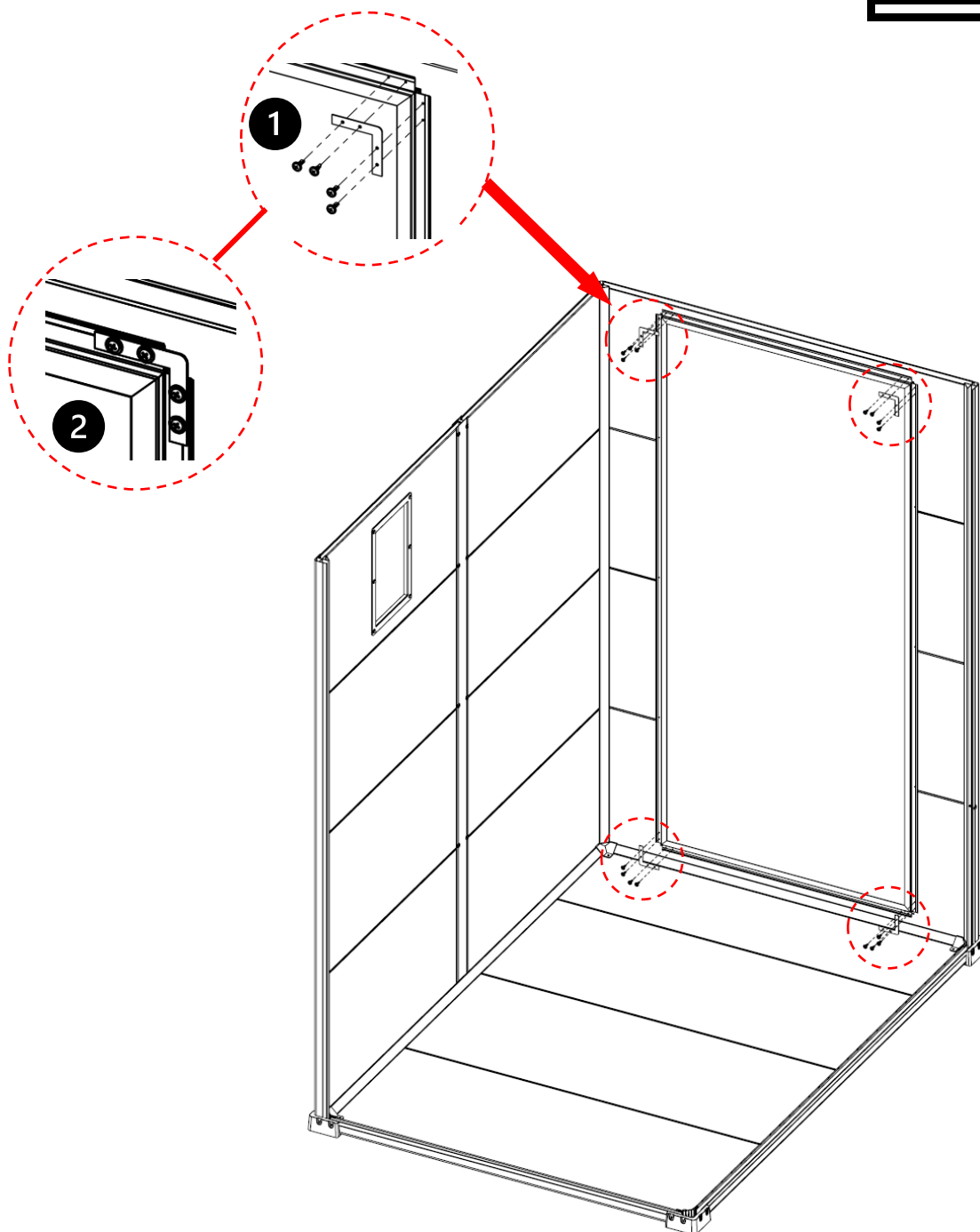

Step 42

6PC

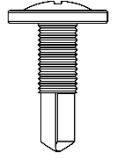

STYW4.2*12

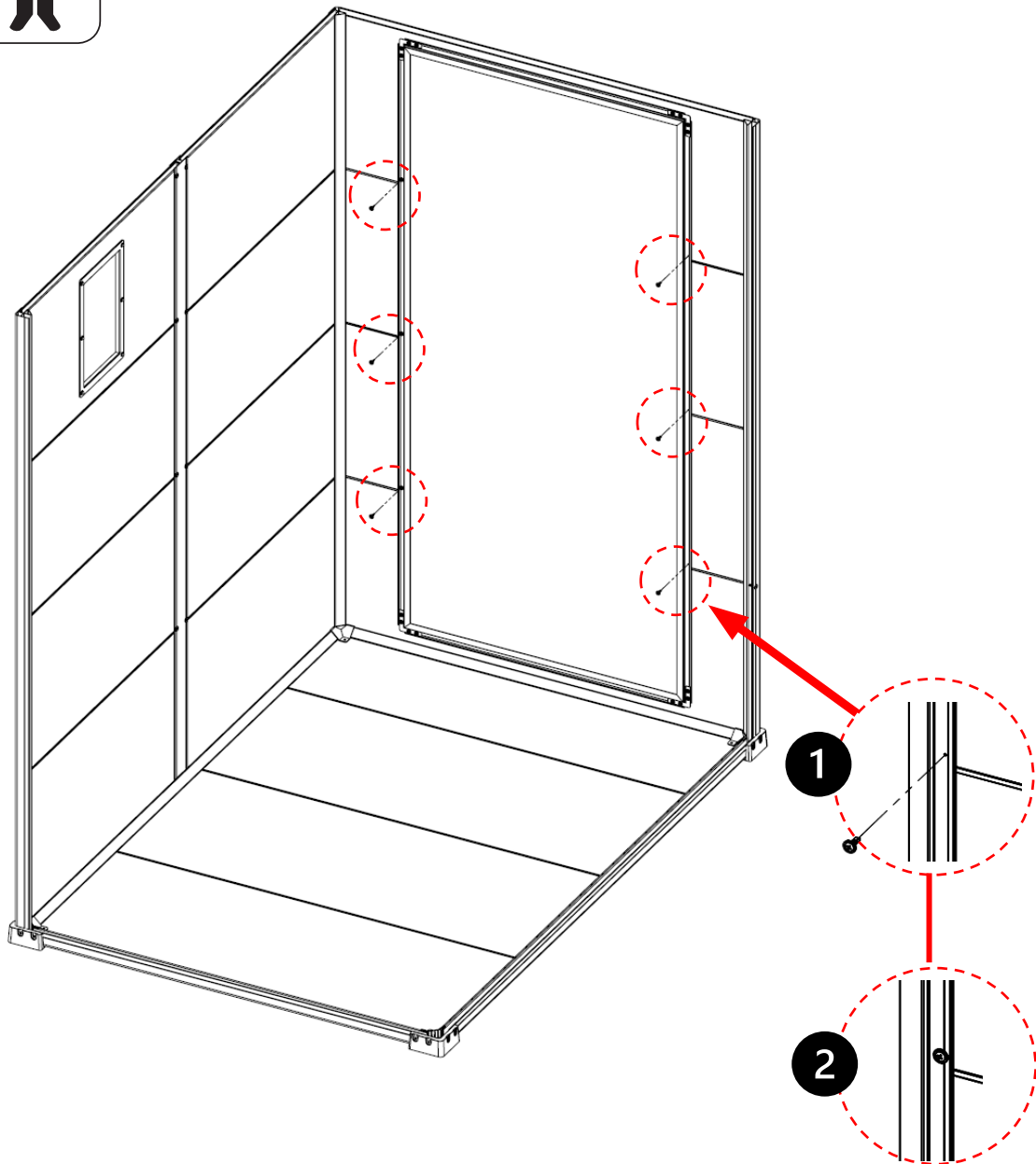
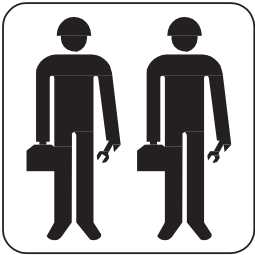

Step 43

2PC

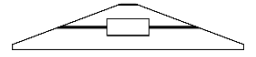

WA-08

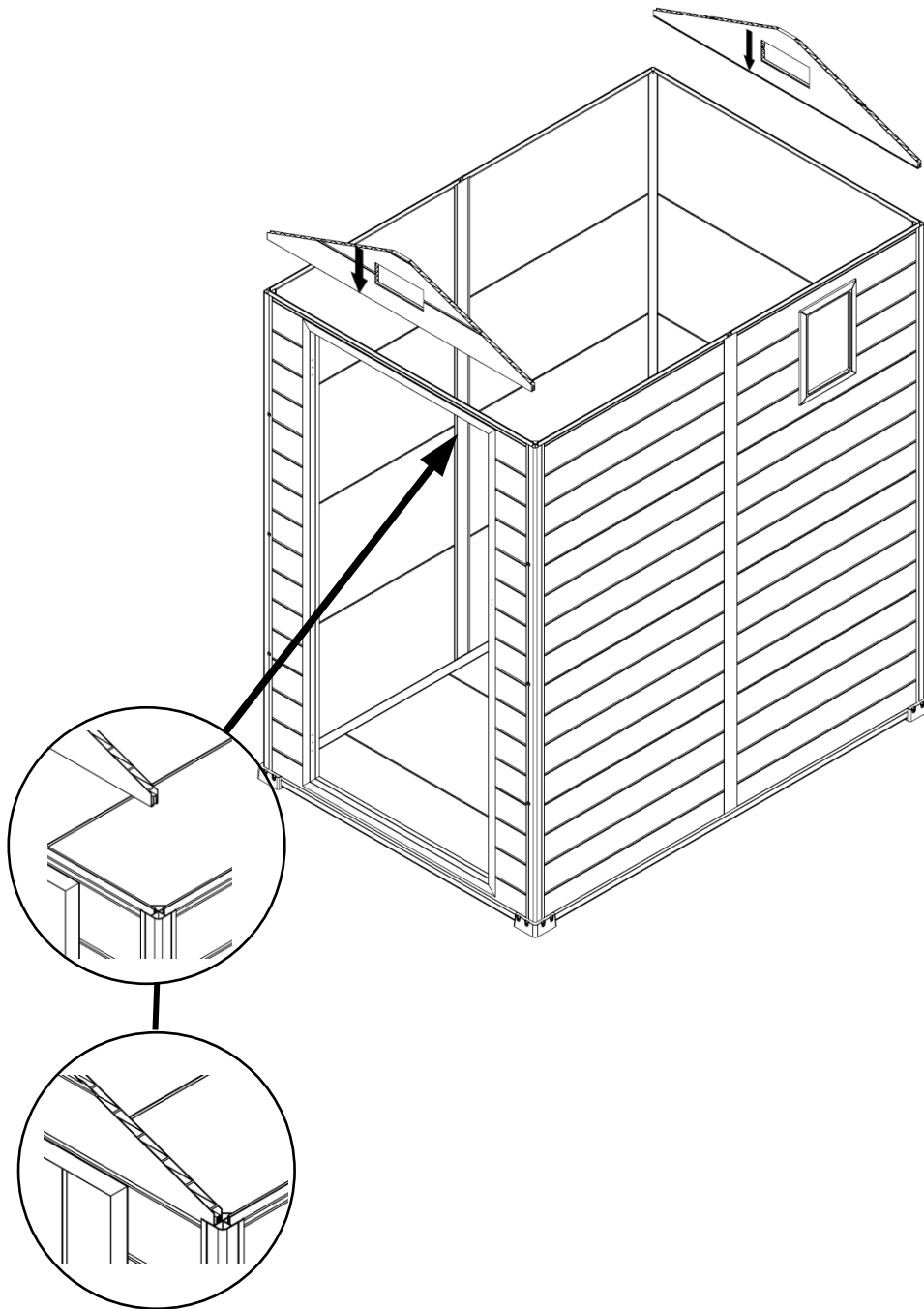

Step 44

6PC



STYW4.2*12

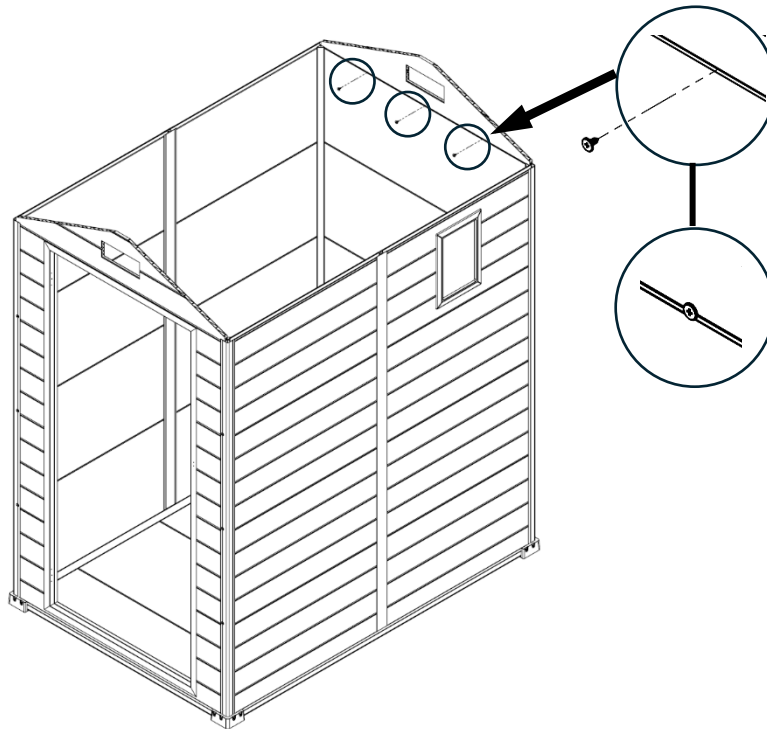

Step 45

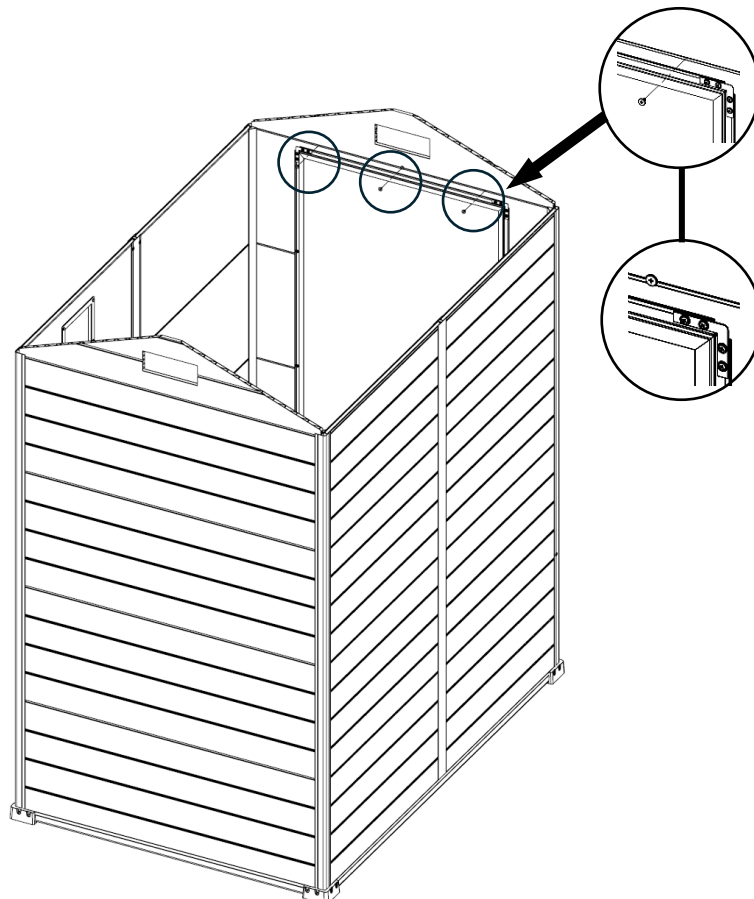

Roof parts

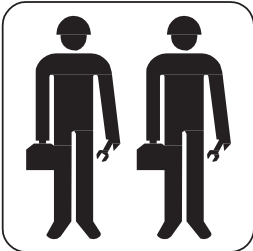

Note: The roof stripes are facing upwards

Use a spatula to make it easier to insert the panel

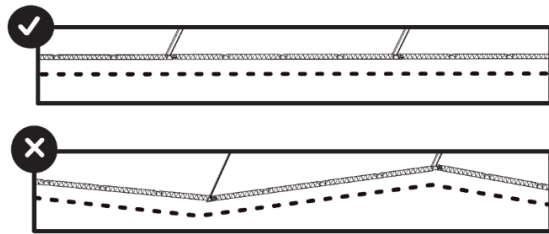
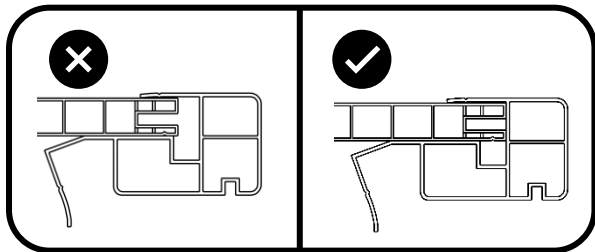
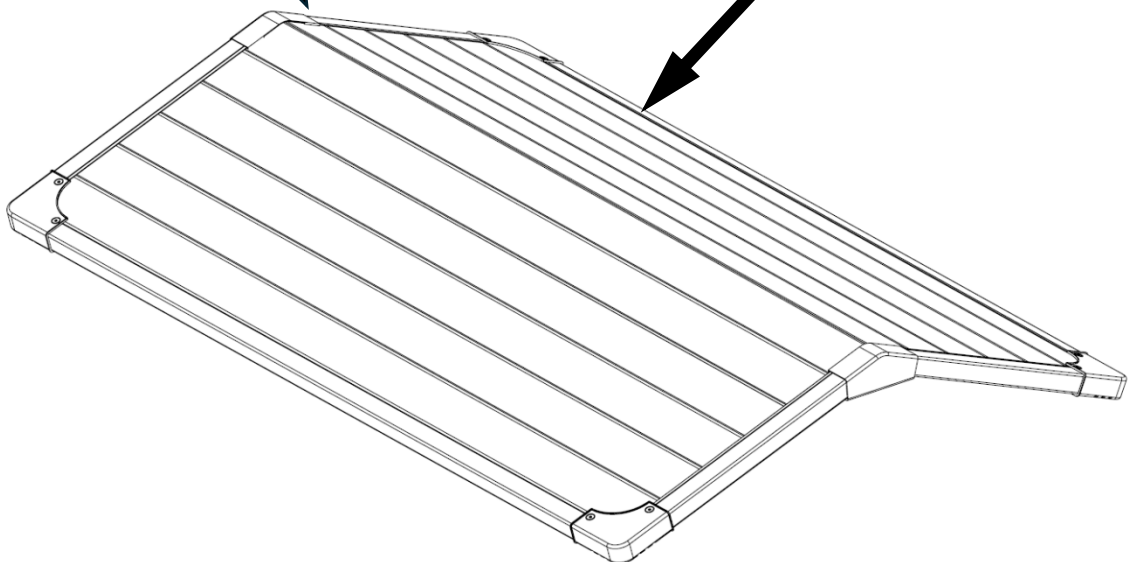
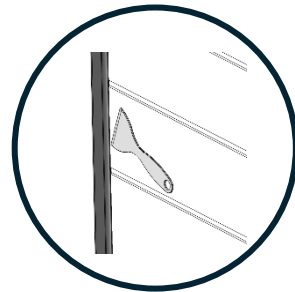
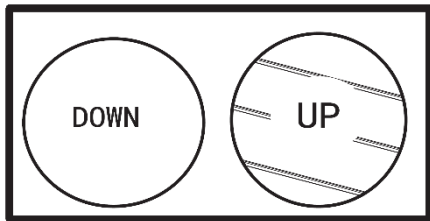

During installation, the plate remains vertical and cannot

Step 46

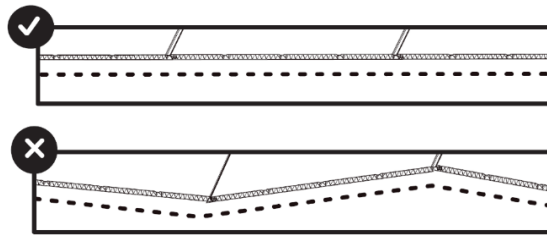

During installation, the plate remains vertical and cannot

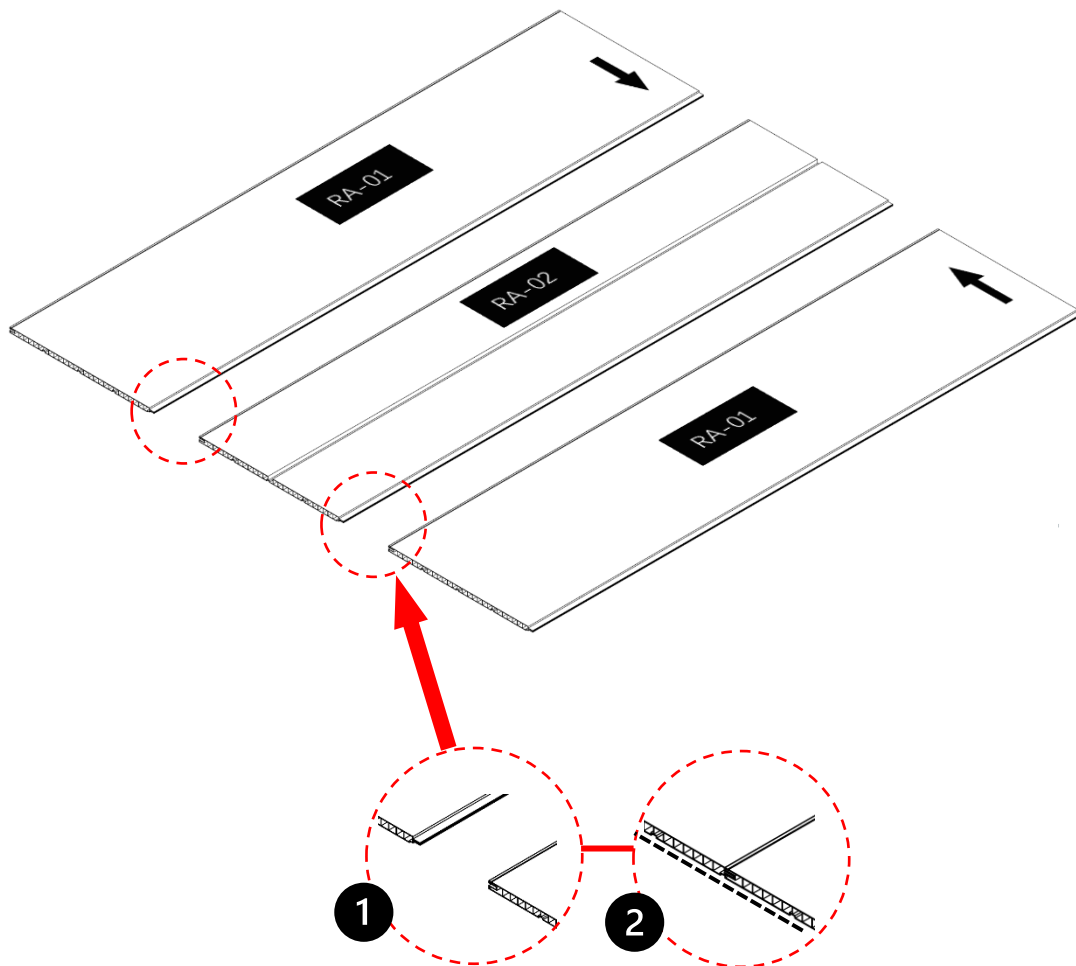
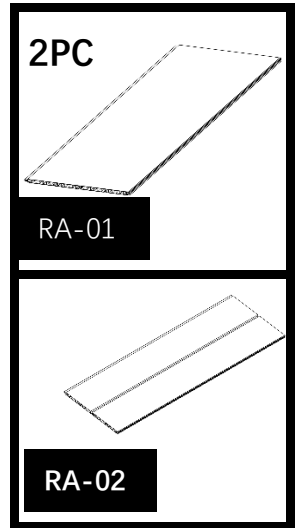

Step 47

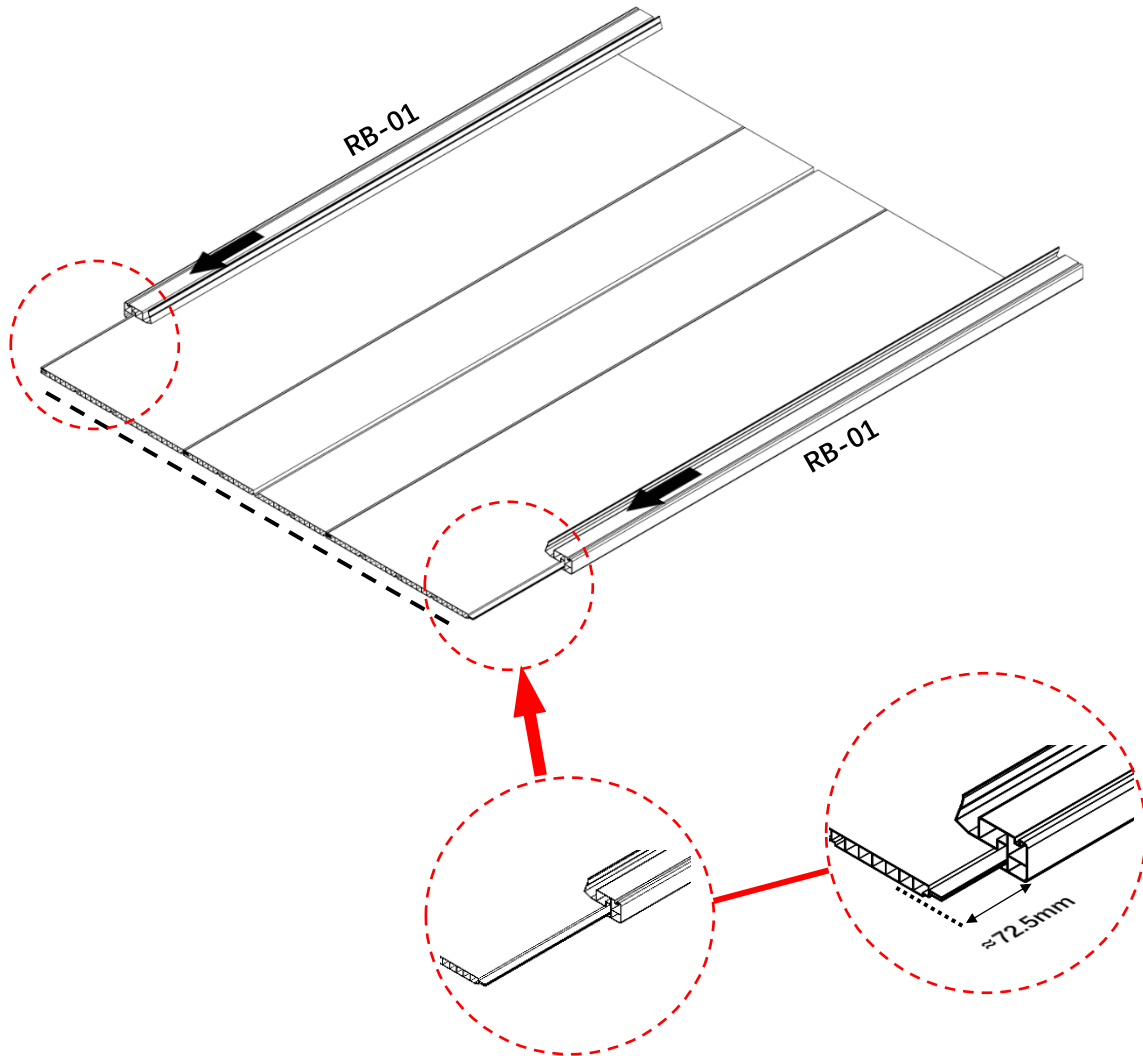
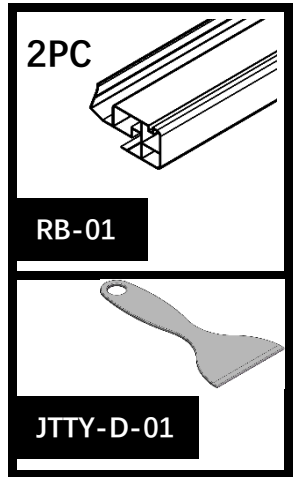
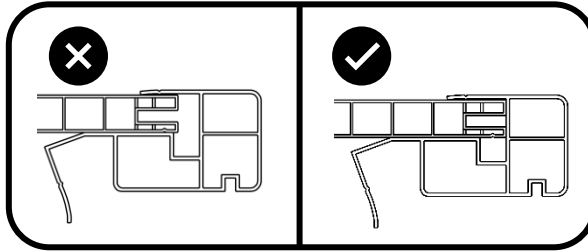
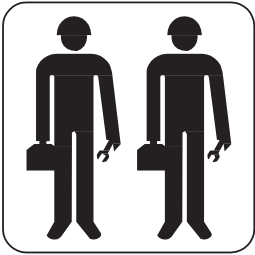

Step 48

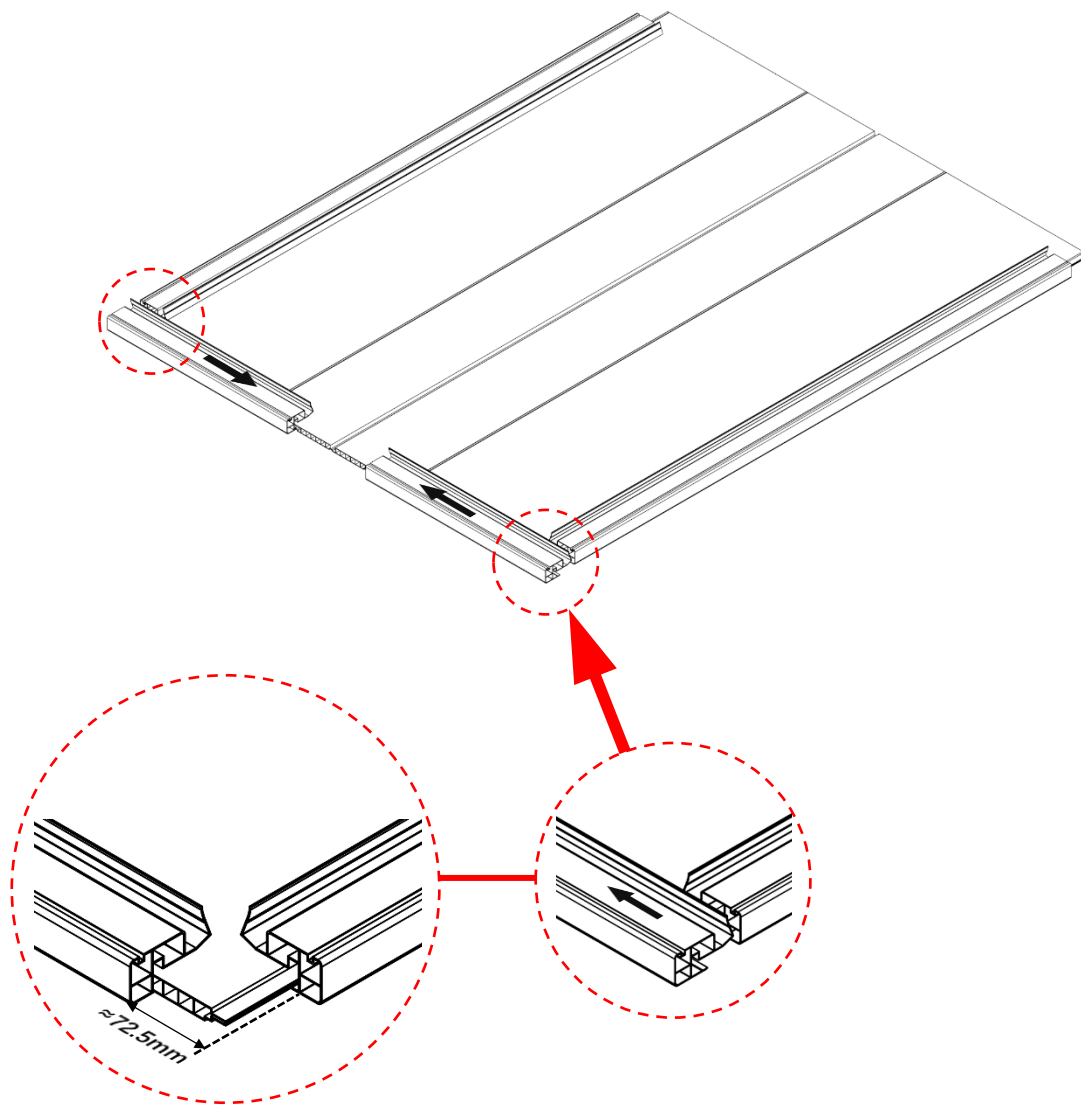
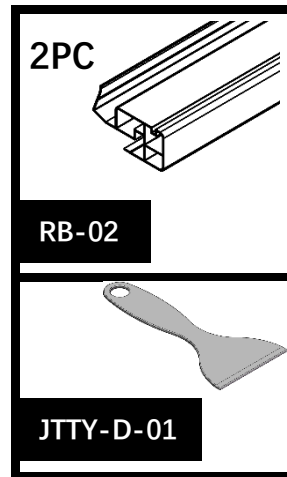
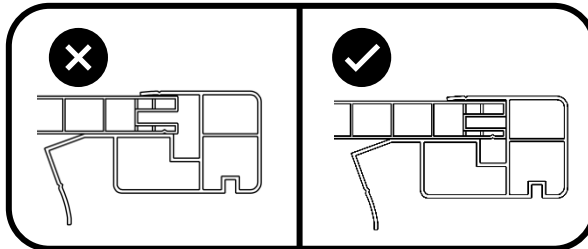
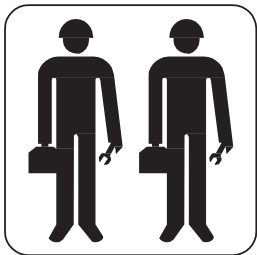

Step 49

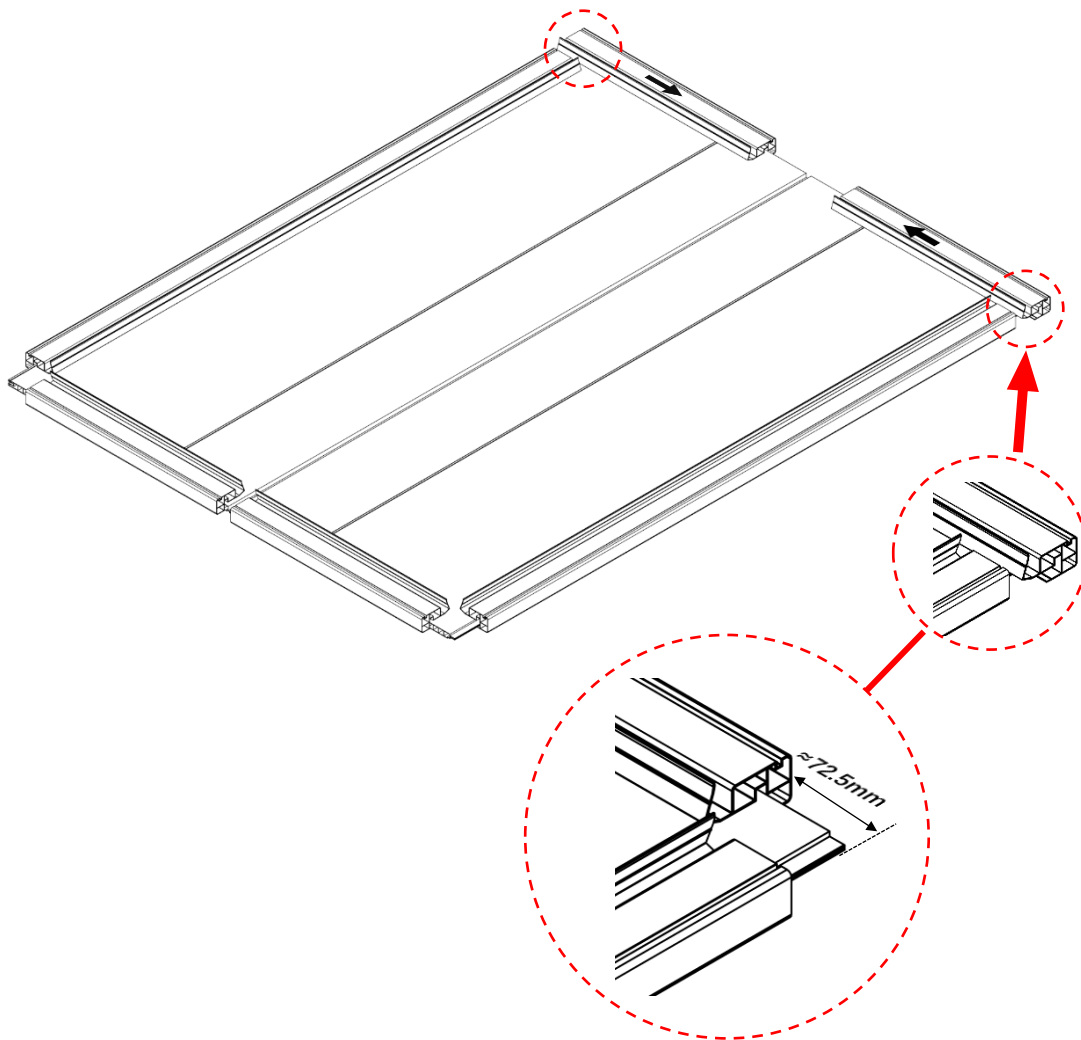
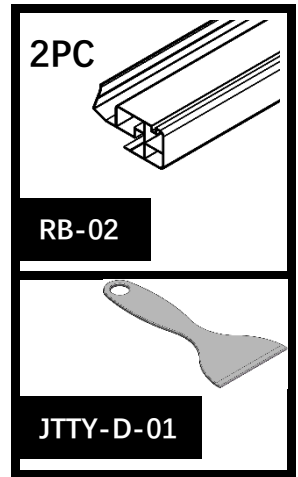
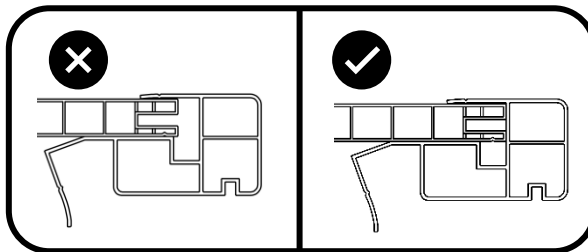
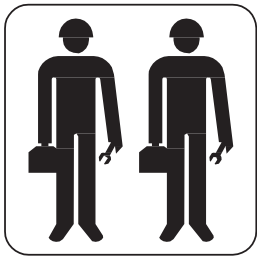

Step 50

4PC

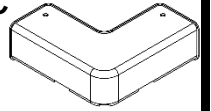

JTRB-02

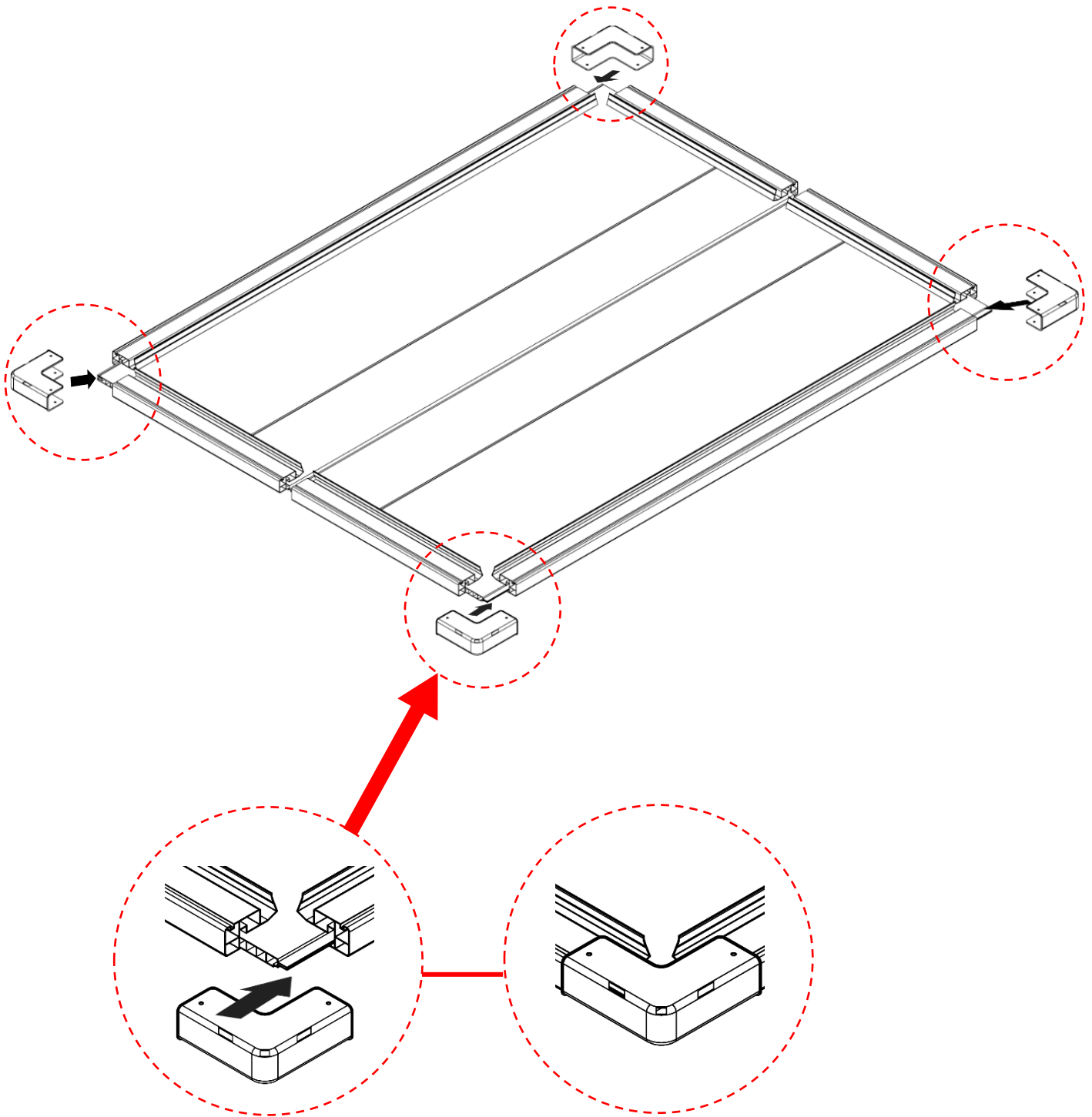

Step 51

8PC

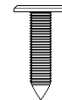

ST4.2*20

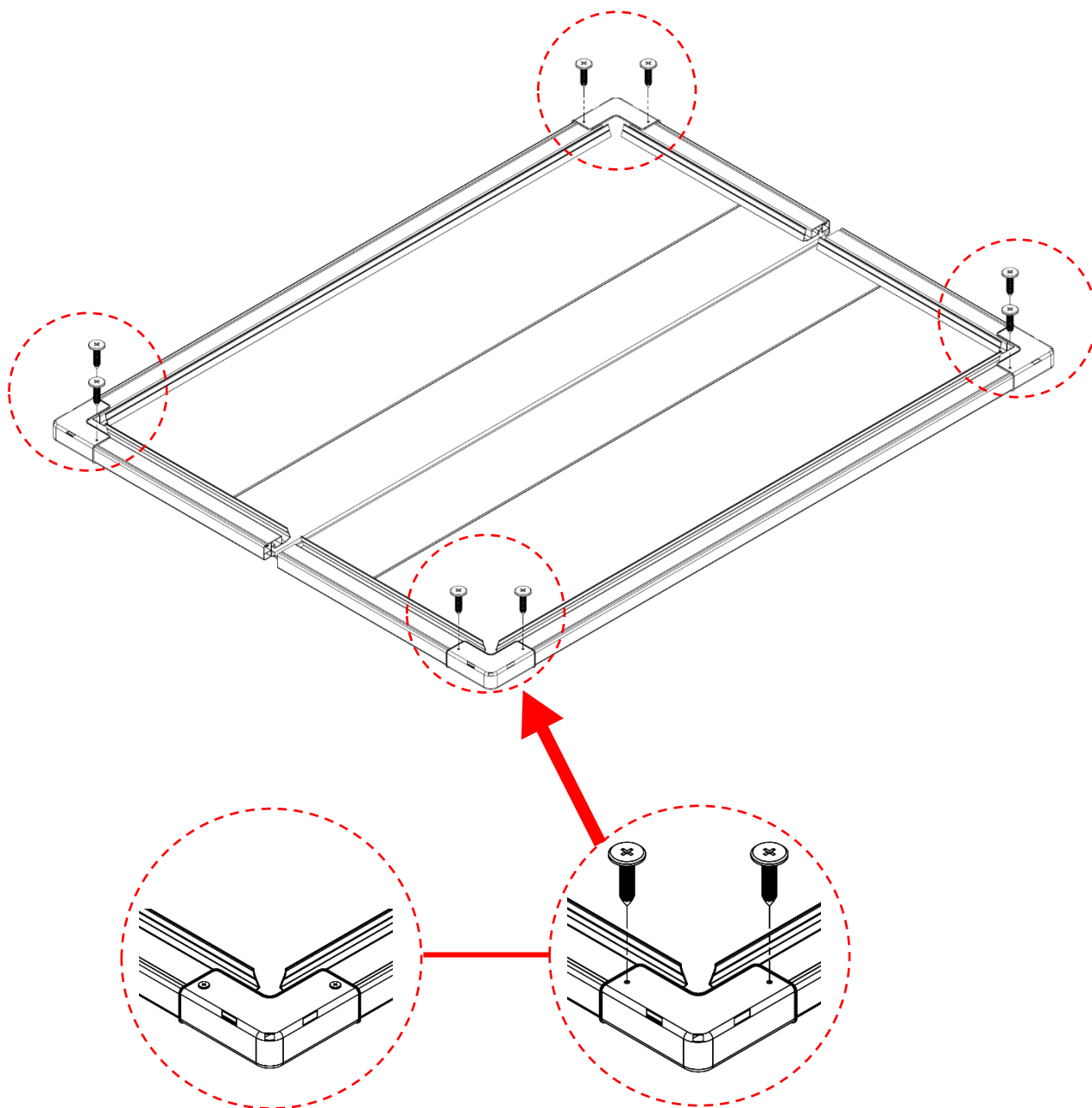

Step 52

Note: The roof stripes are facing upwards

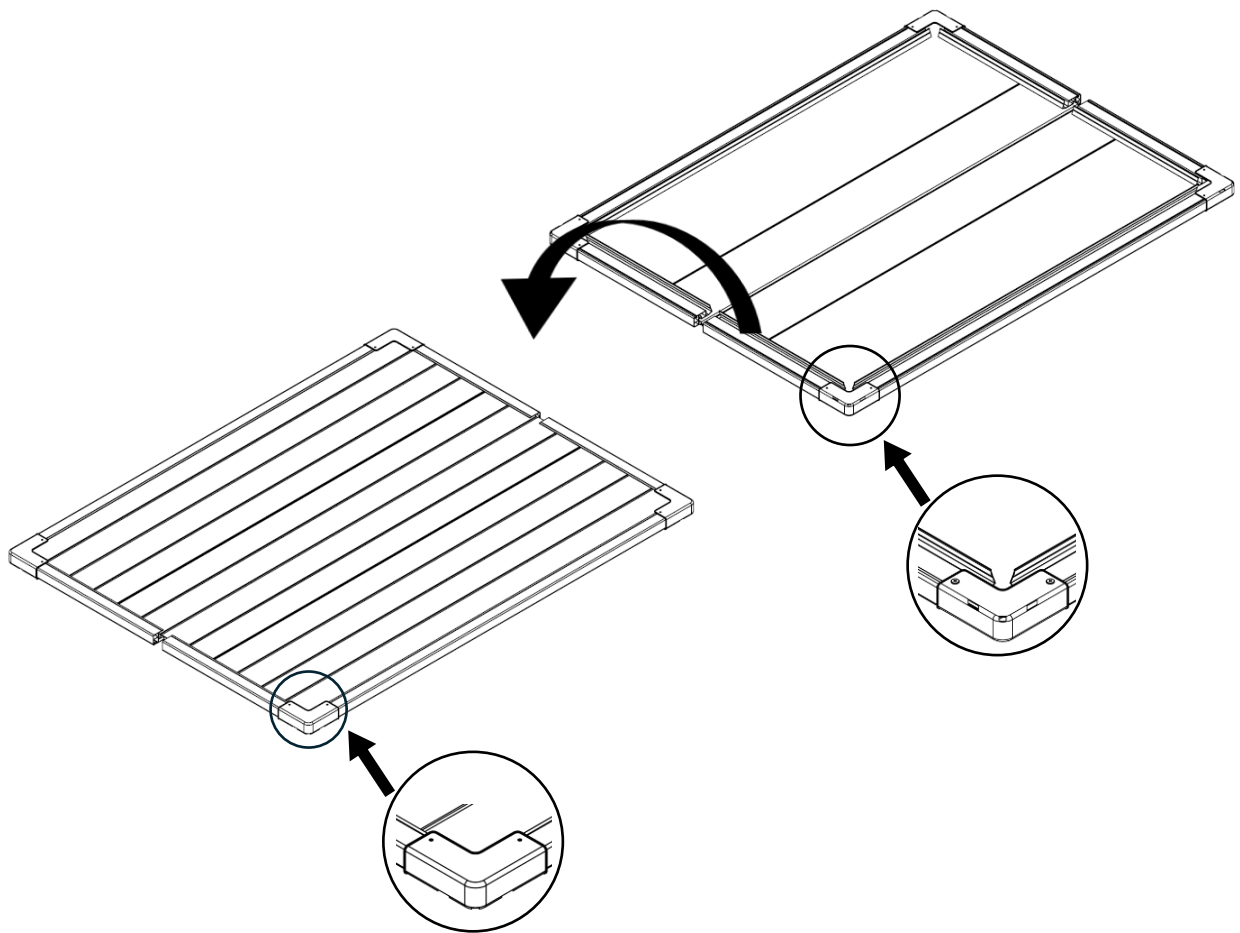
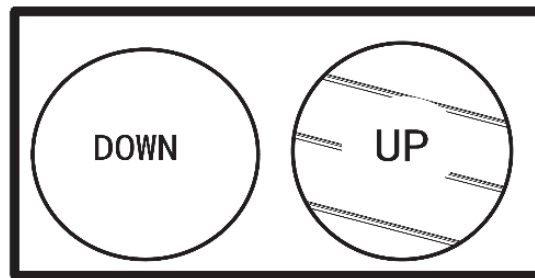

Step 53

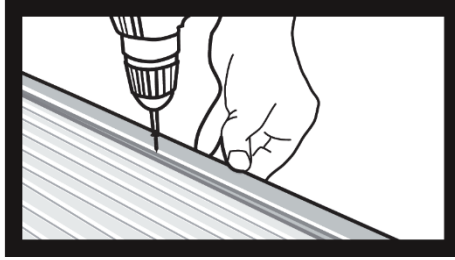

18PC



ST4.2*20

Fix the screws on the profile along the marking line

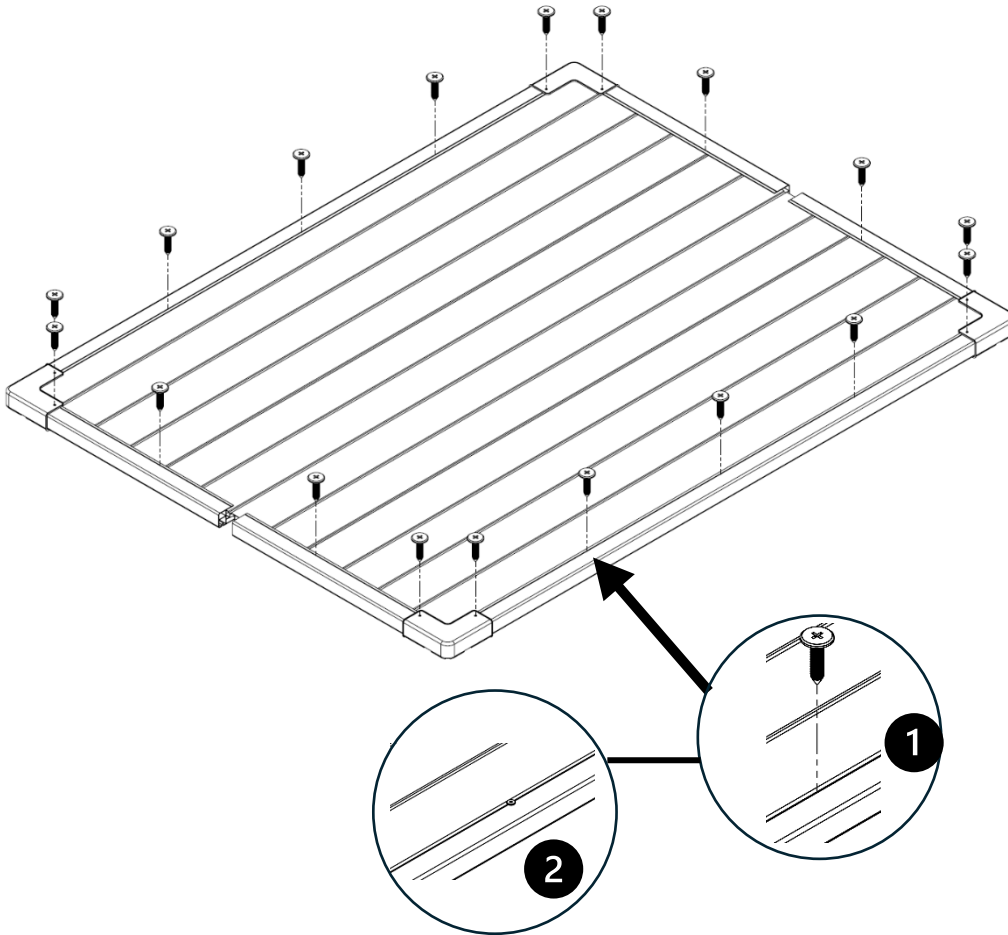

Step 54

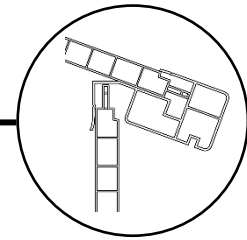
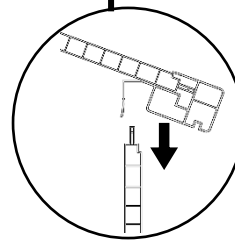
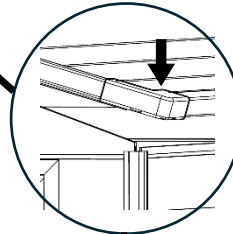
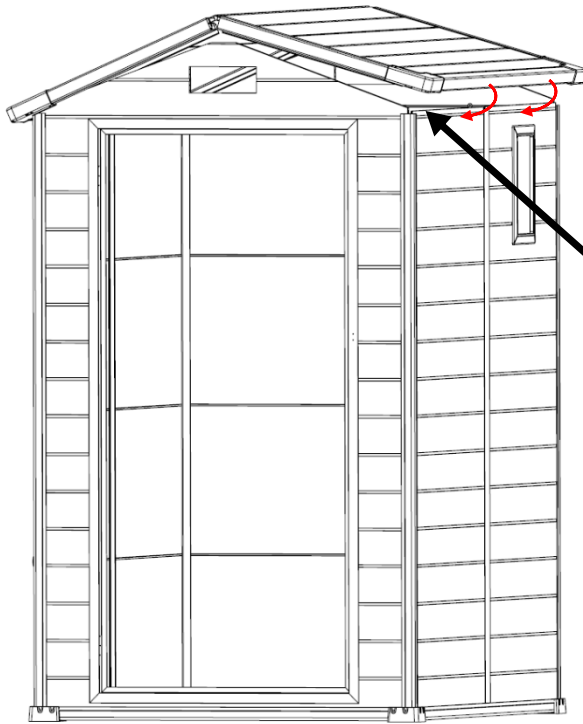
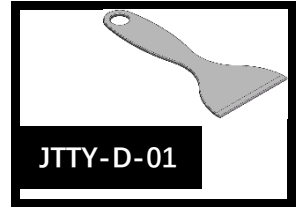
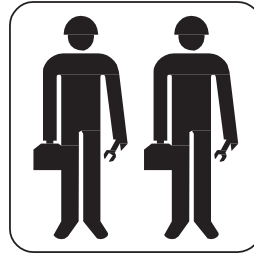

The panels fit perfectly in the profile

Step 55

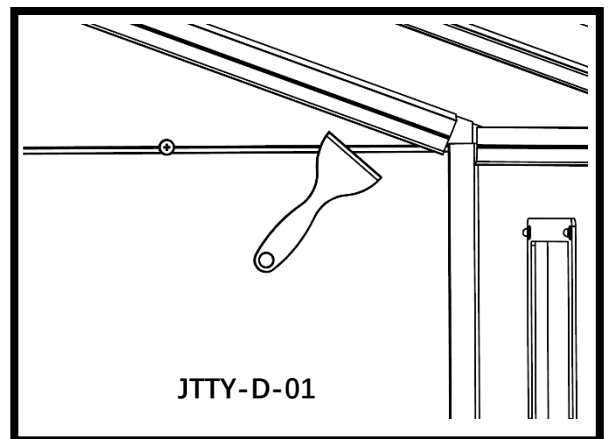
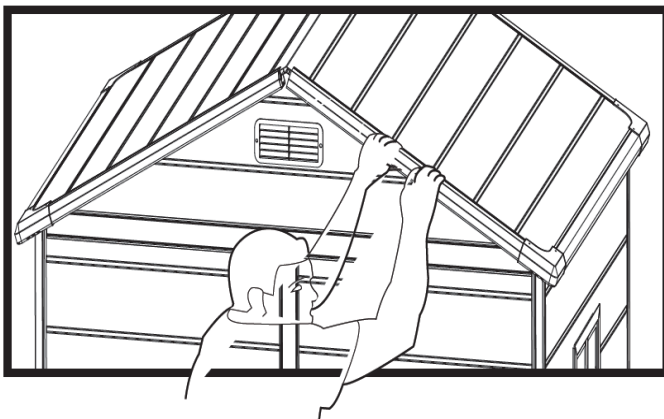
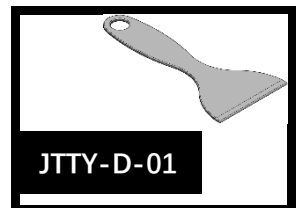
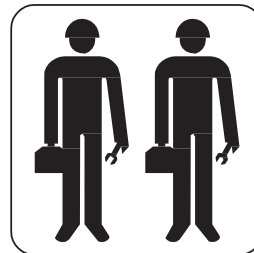

The roof profile fits perfectly to the panel

Step 56

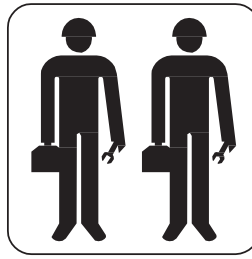

16pc

ST4.2*26

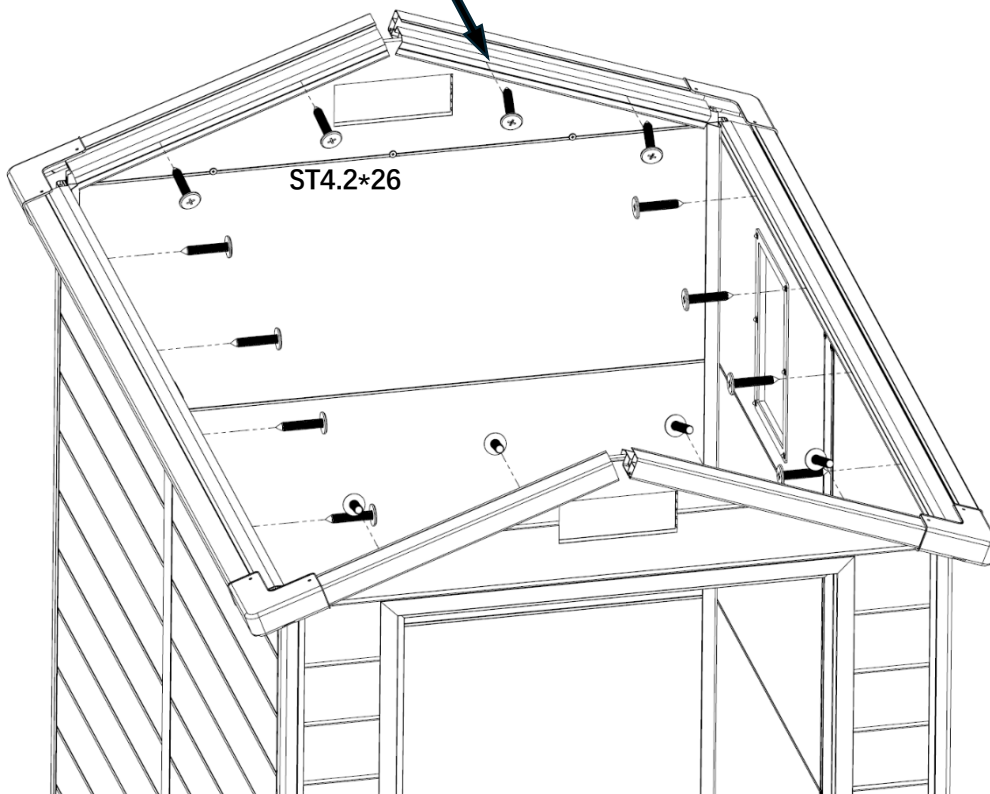
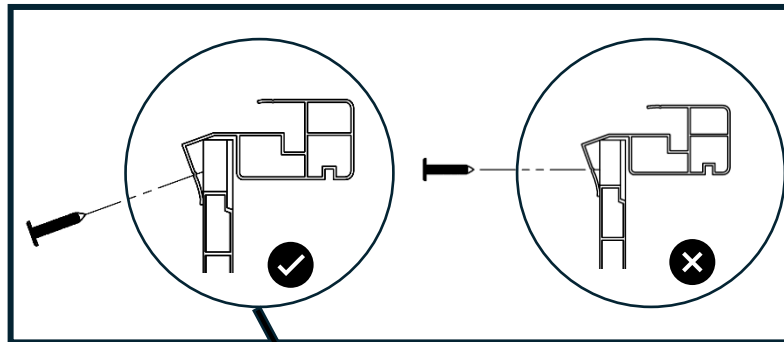

Step 57

16PC

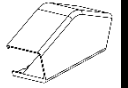

ST4.2*26

4PC

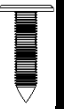

ST4.2*26

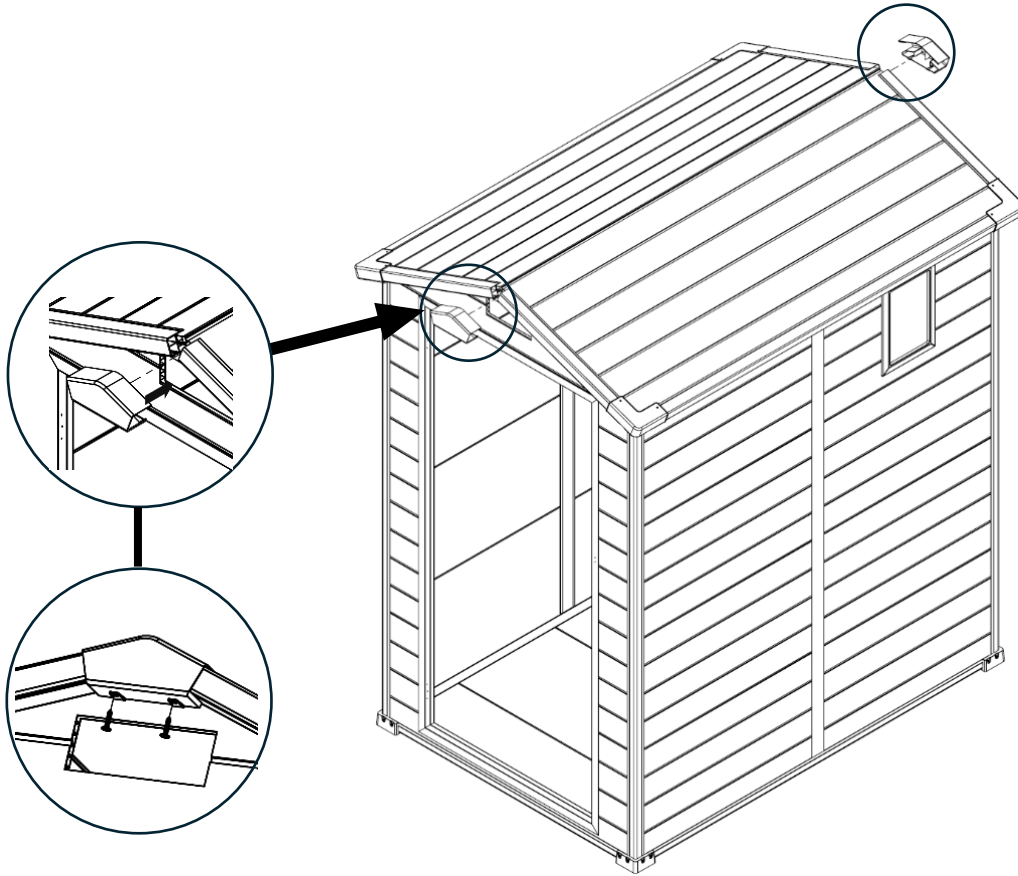

Door parts

Note: The roof stripes are facing upwards

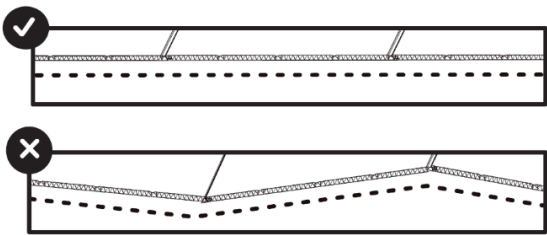
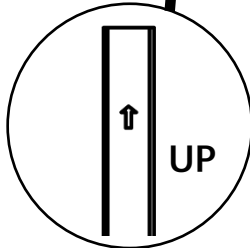
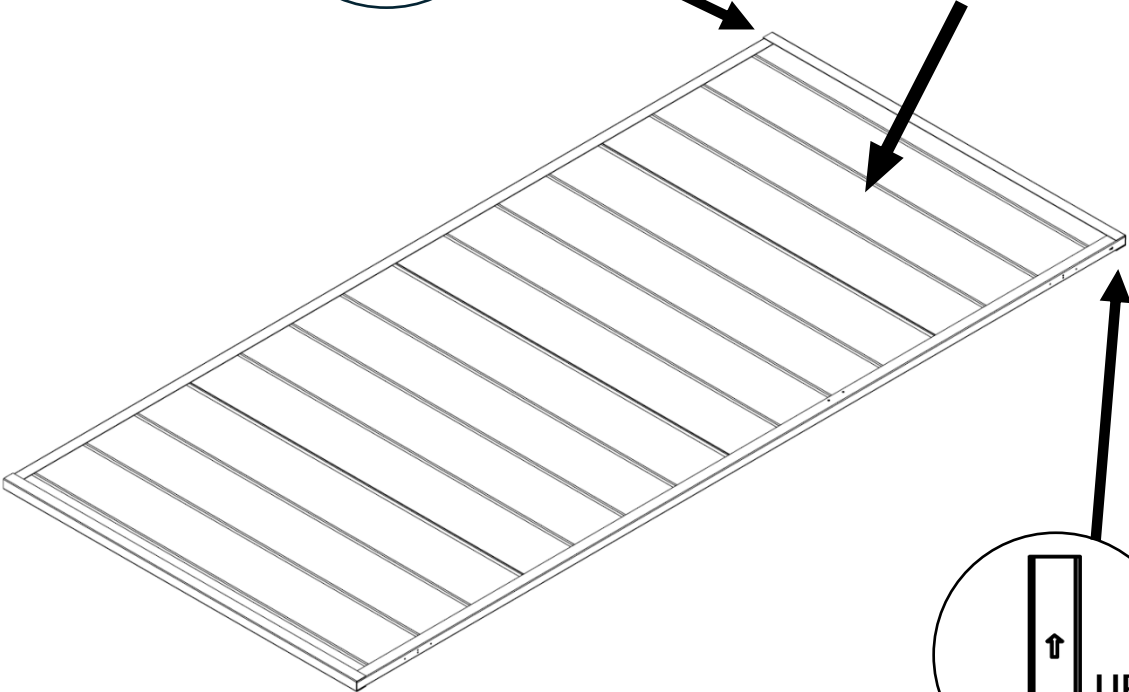
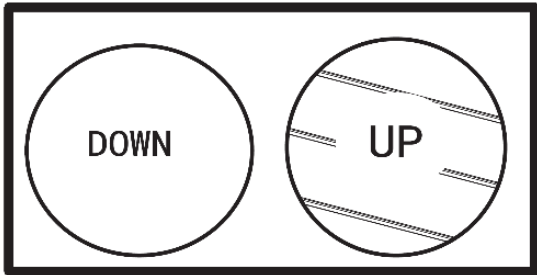
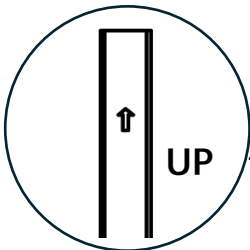

During installation, the plate remains vertical and cannot

Step 58

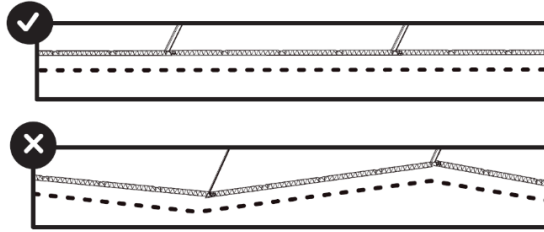

During installation, the plate remains vertical and cannot

1PC



JTMB-WA-01

2PC



JTMB-WA-01

1PC



ST4.2*26

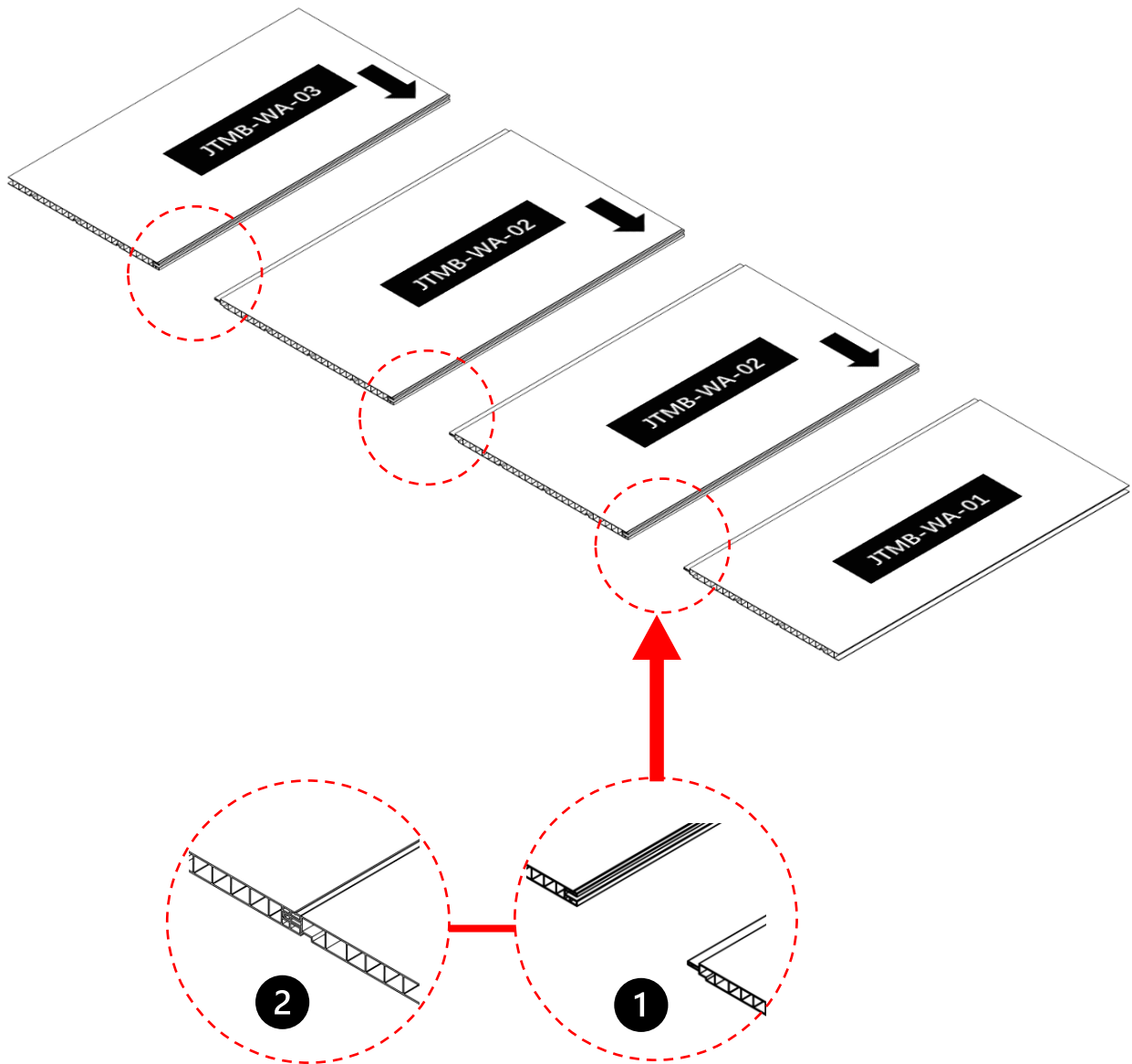

Step 59

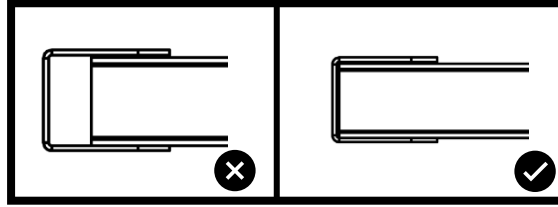

1PC



JTMB-WC-01

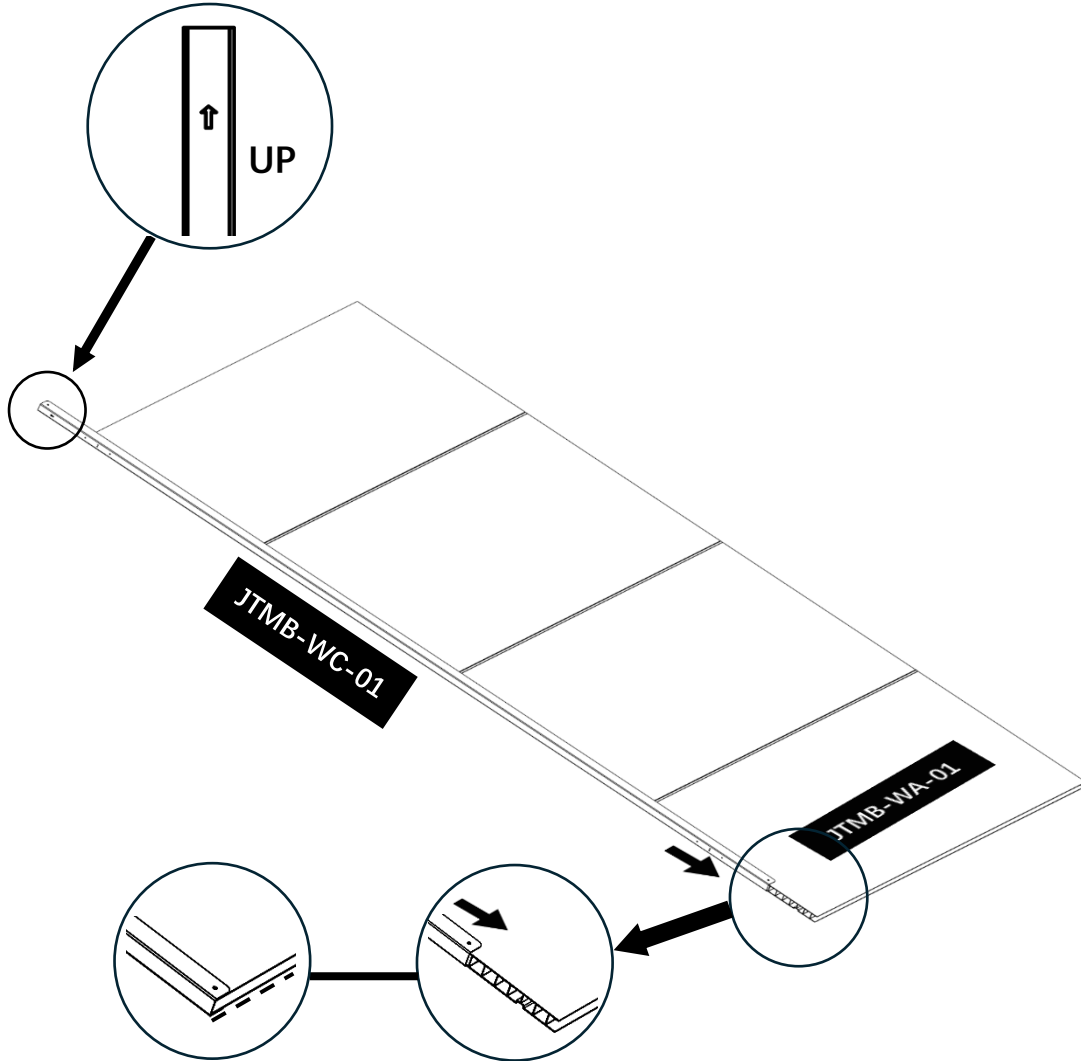

Step 60

1PC



JTMB-WC-02

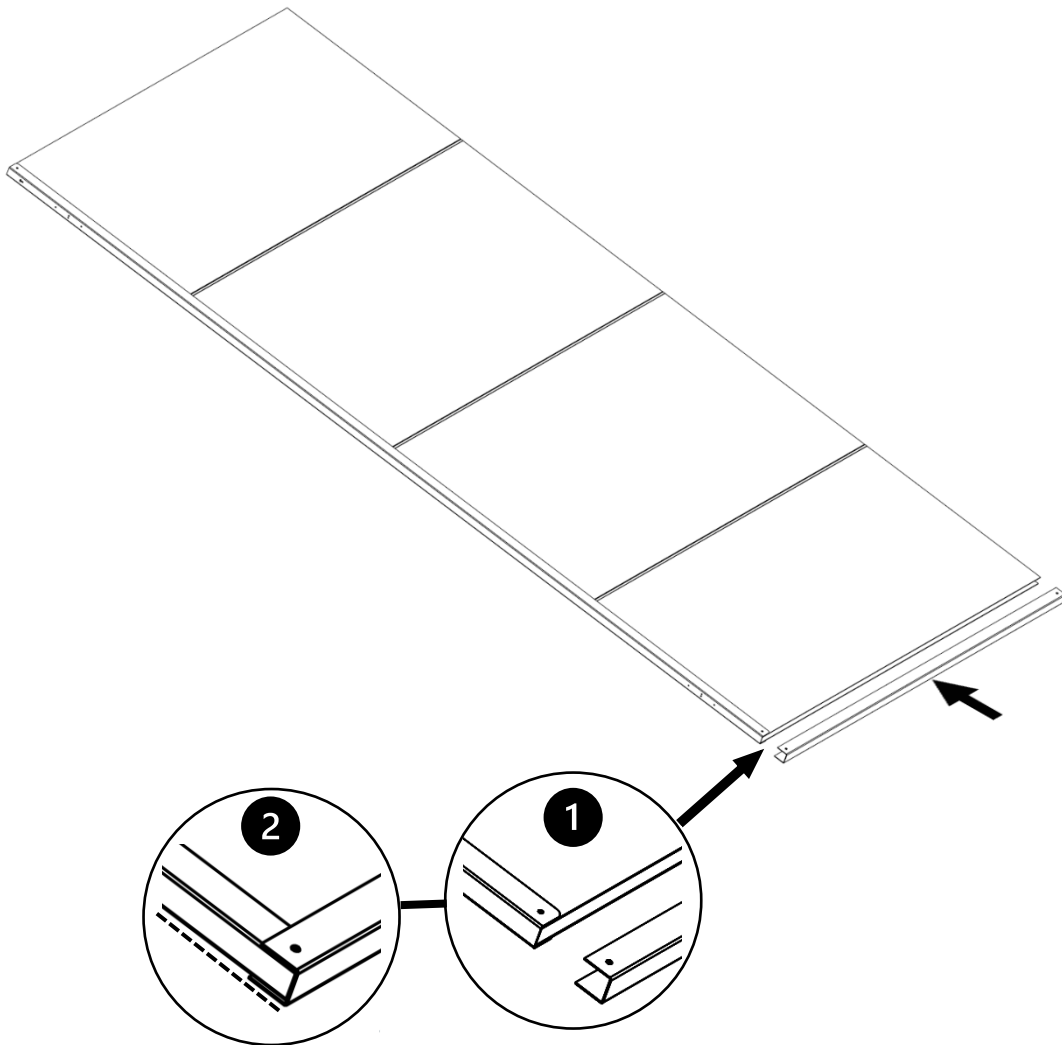

Step 61

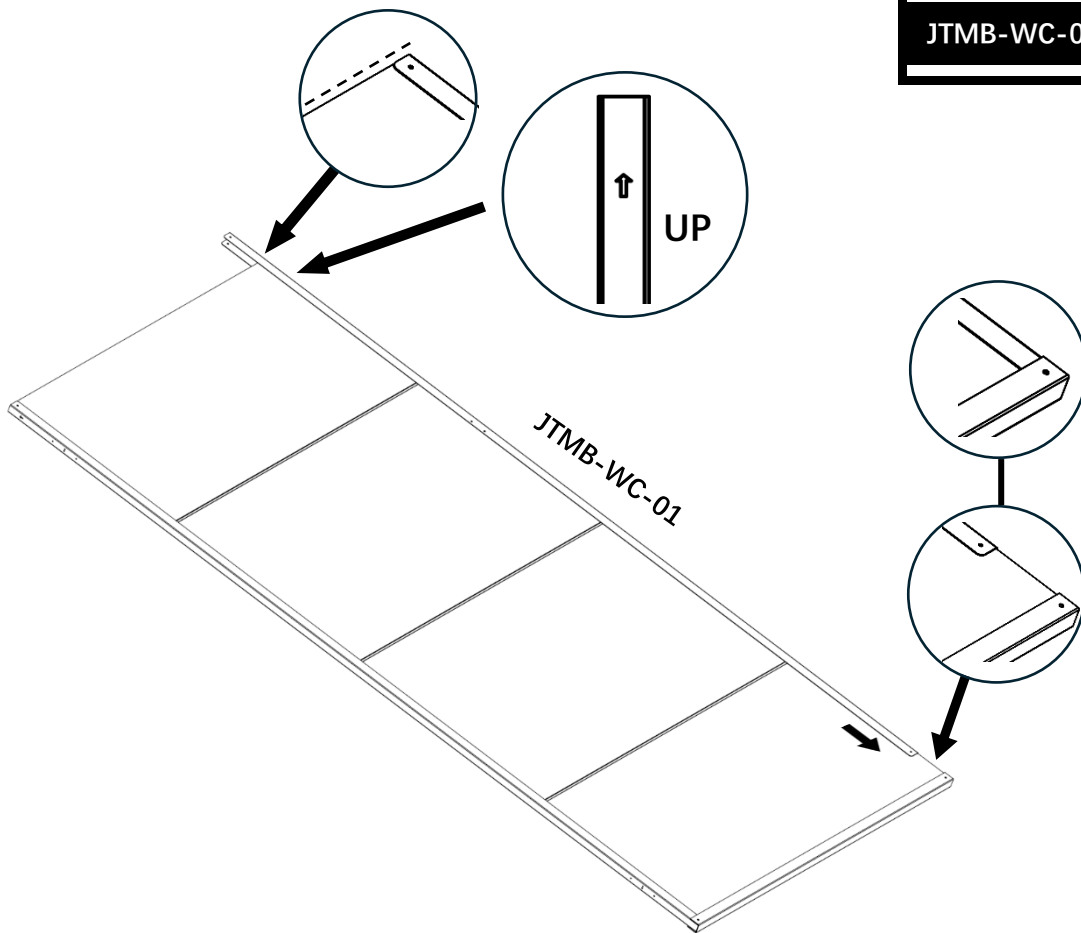

Step 62

1PC

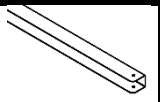

JTMB-WC-02

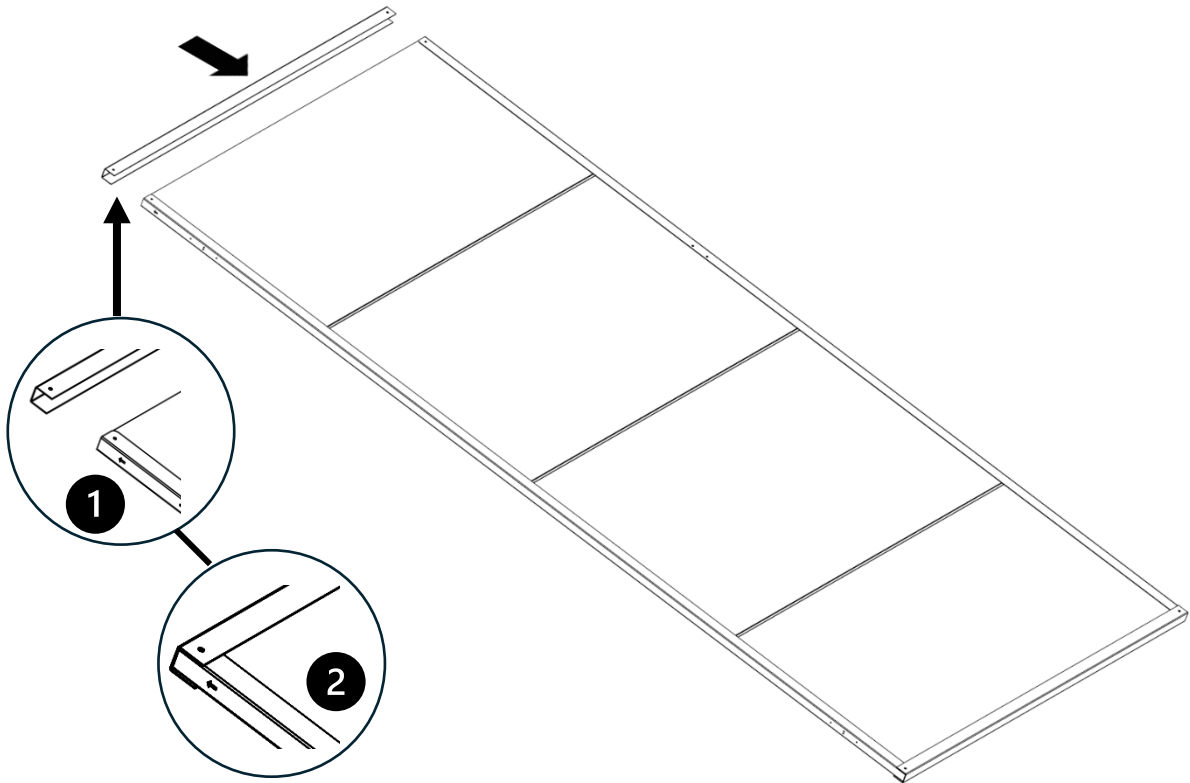

Step 63

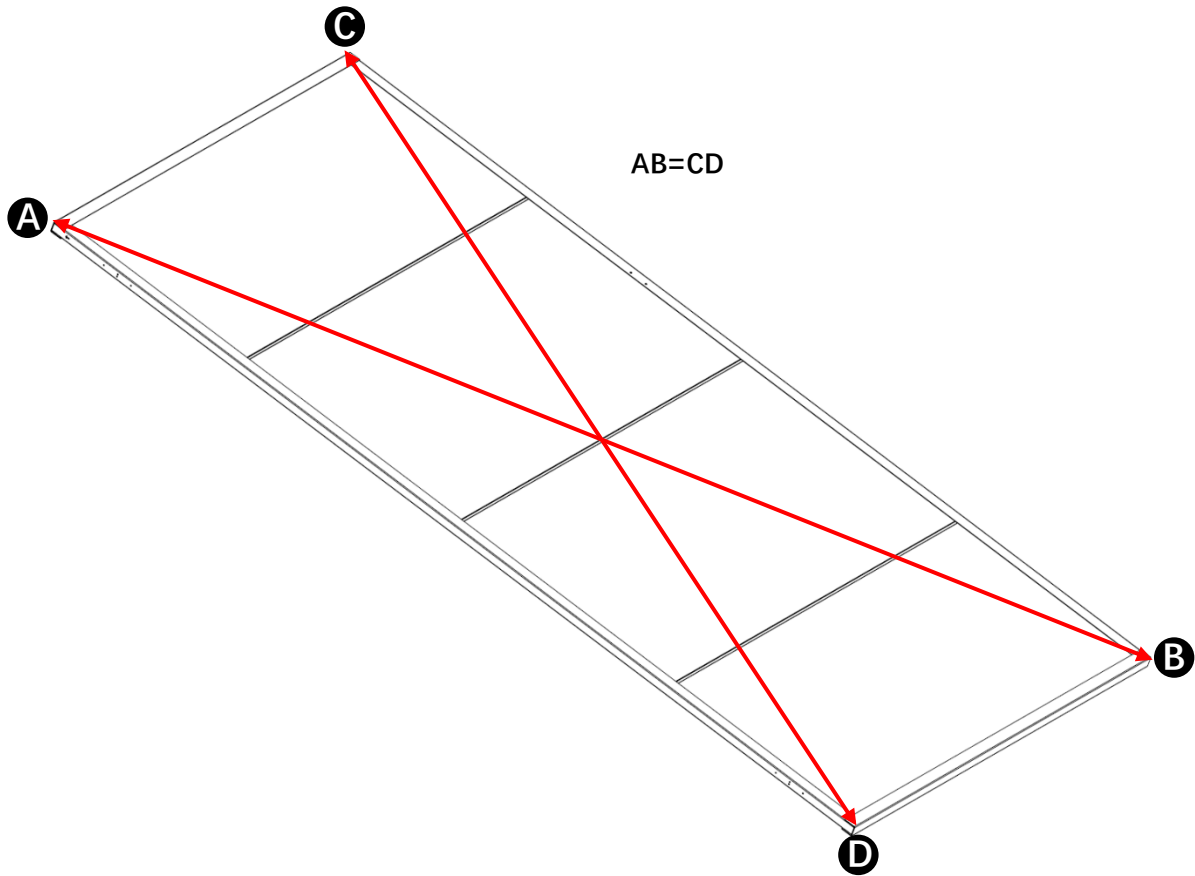
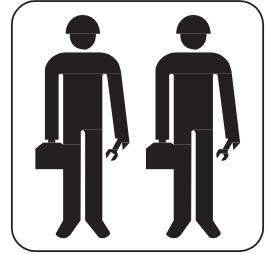

Step 64

10PC

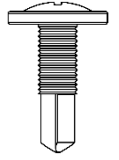

STYW4.2*12

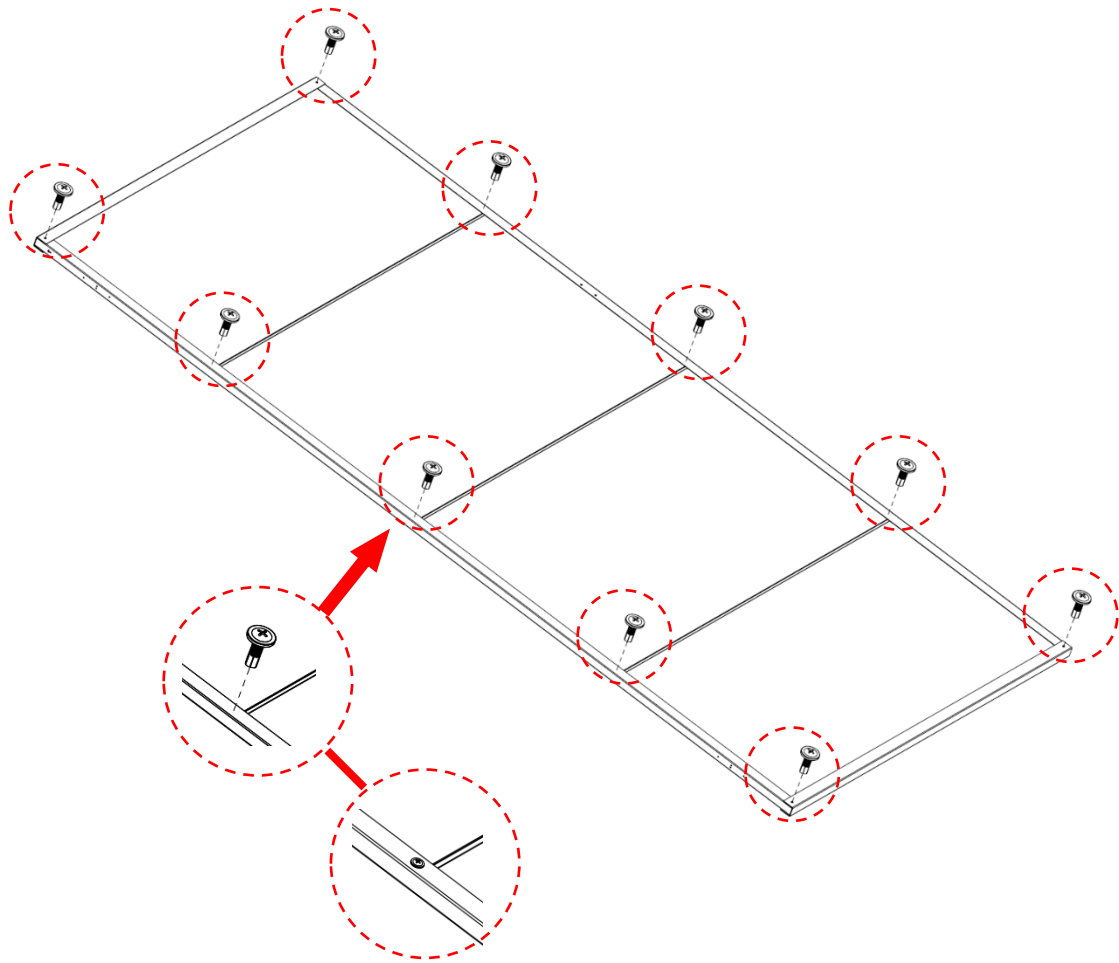

Step 65

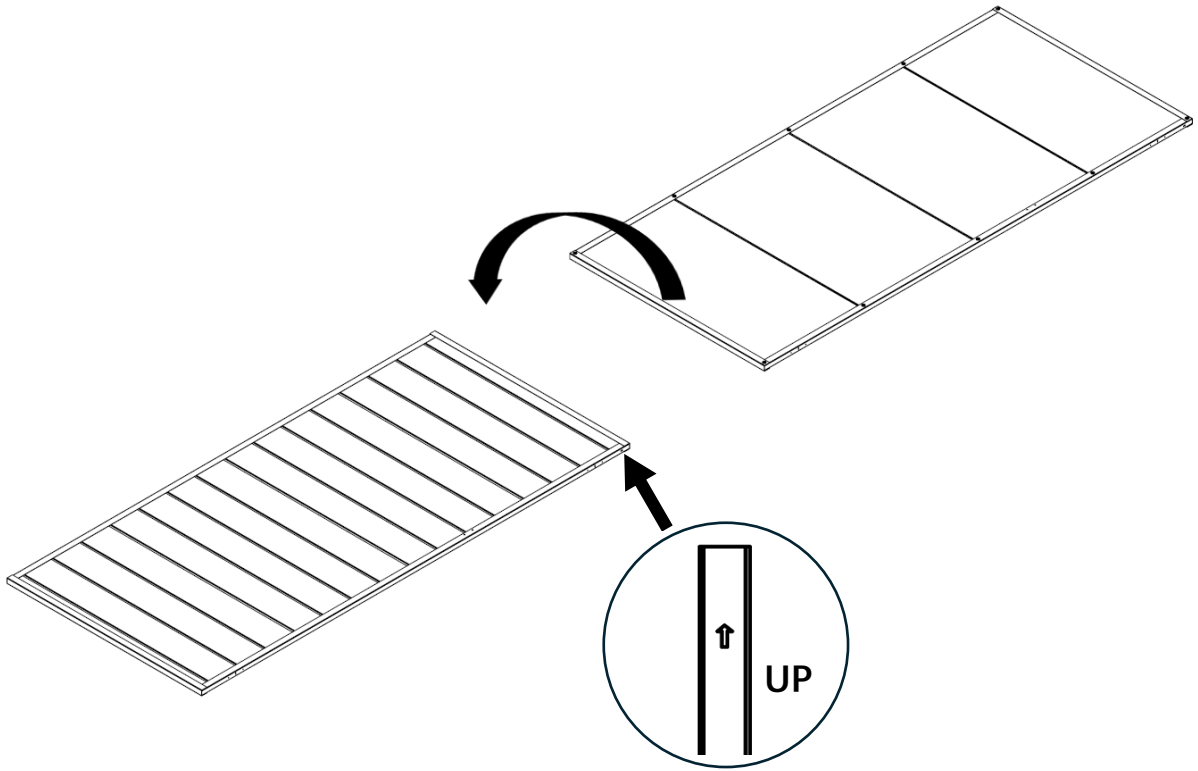

Step 66

6PC



ST4.2*12

2PC

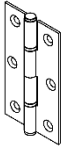

WD-01

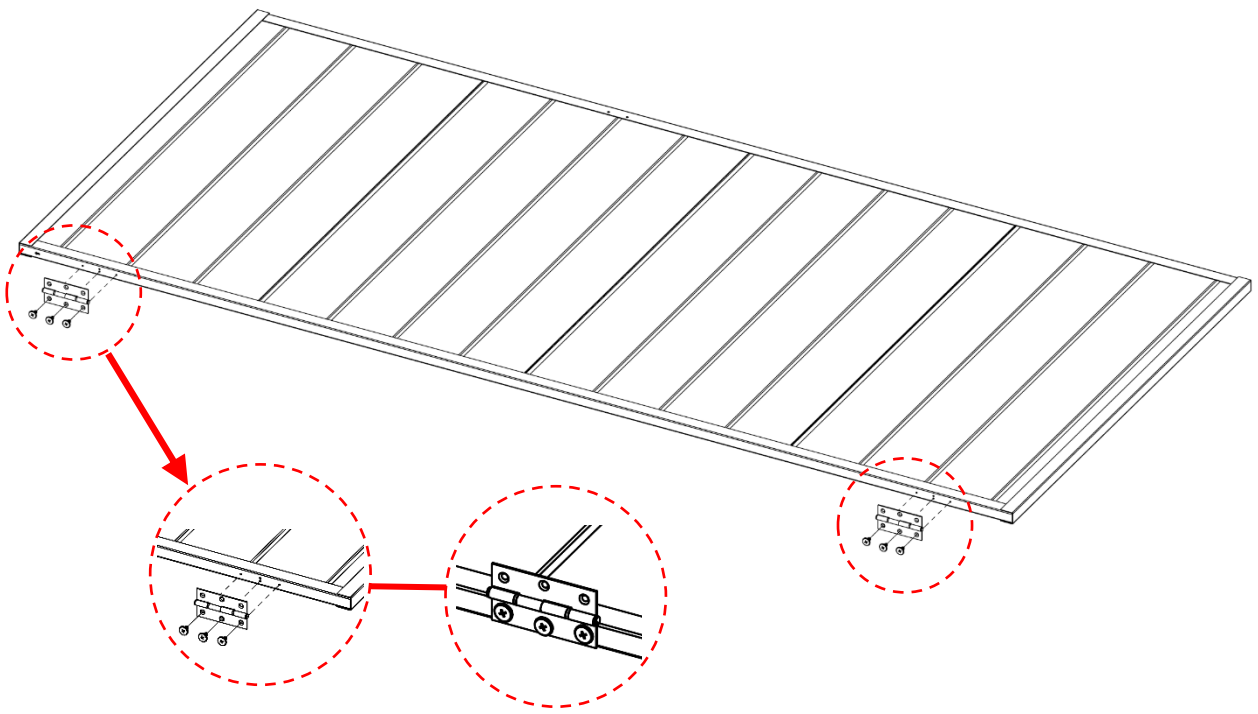

Step 67

6PC



ST4.2*12

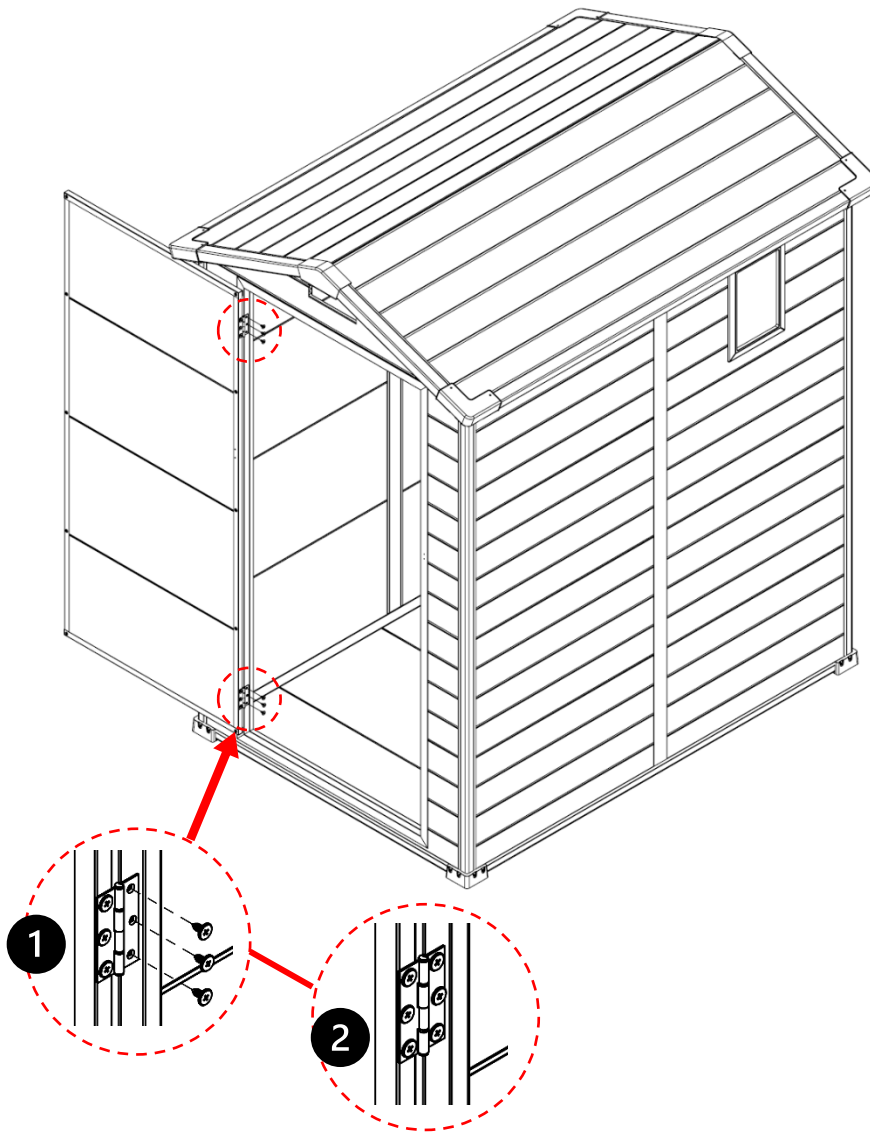

Step 68

4PC

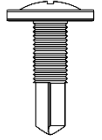

STYW4.2*12

1PC



WD-02

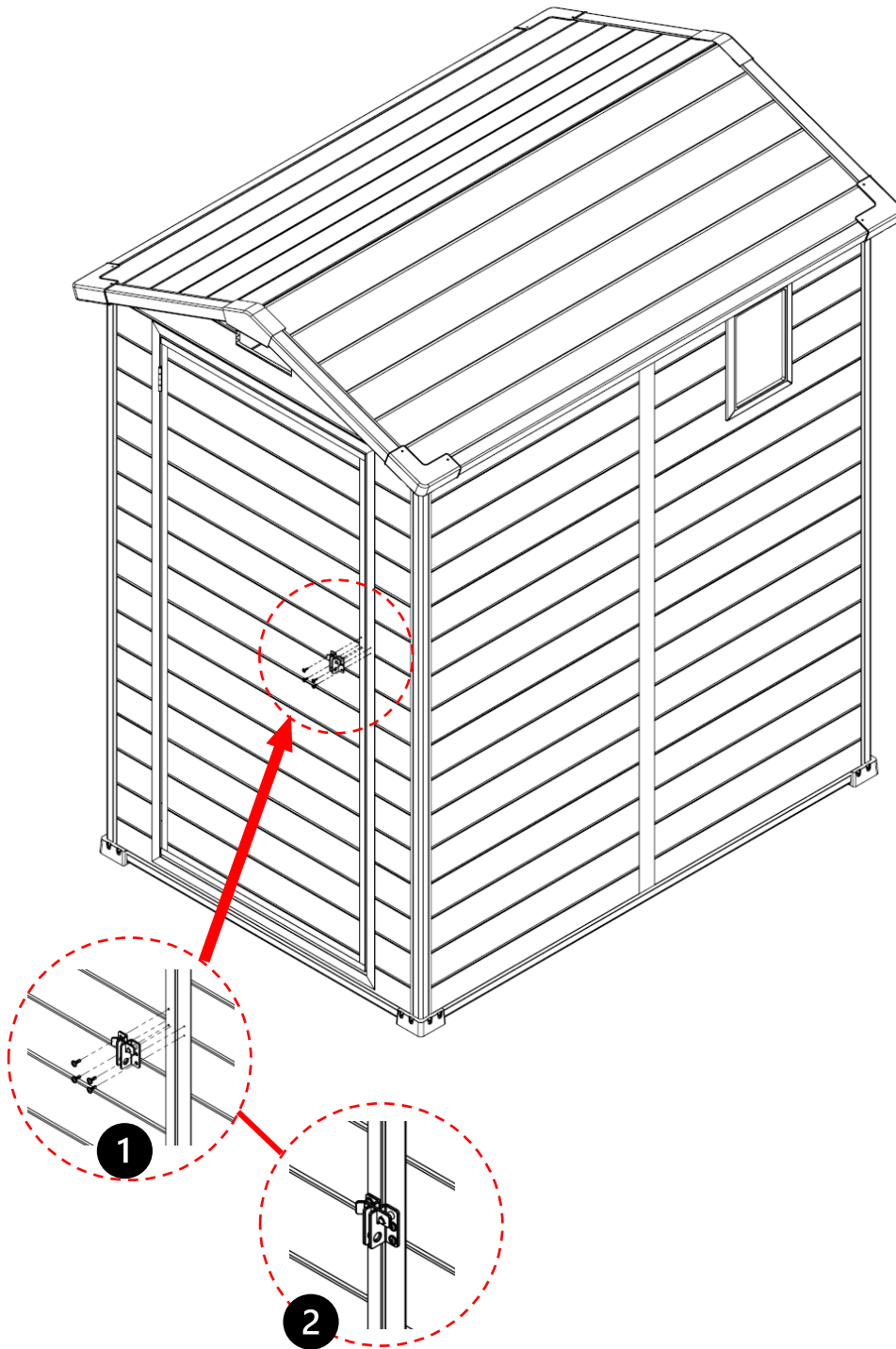

Step 69

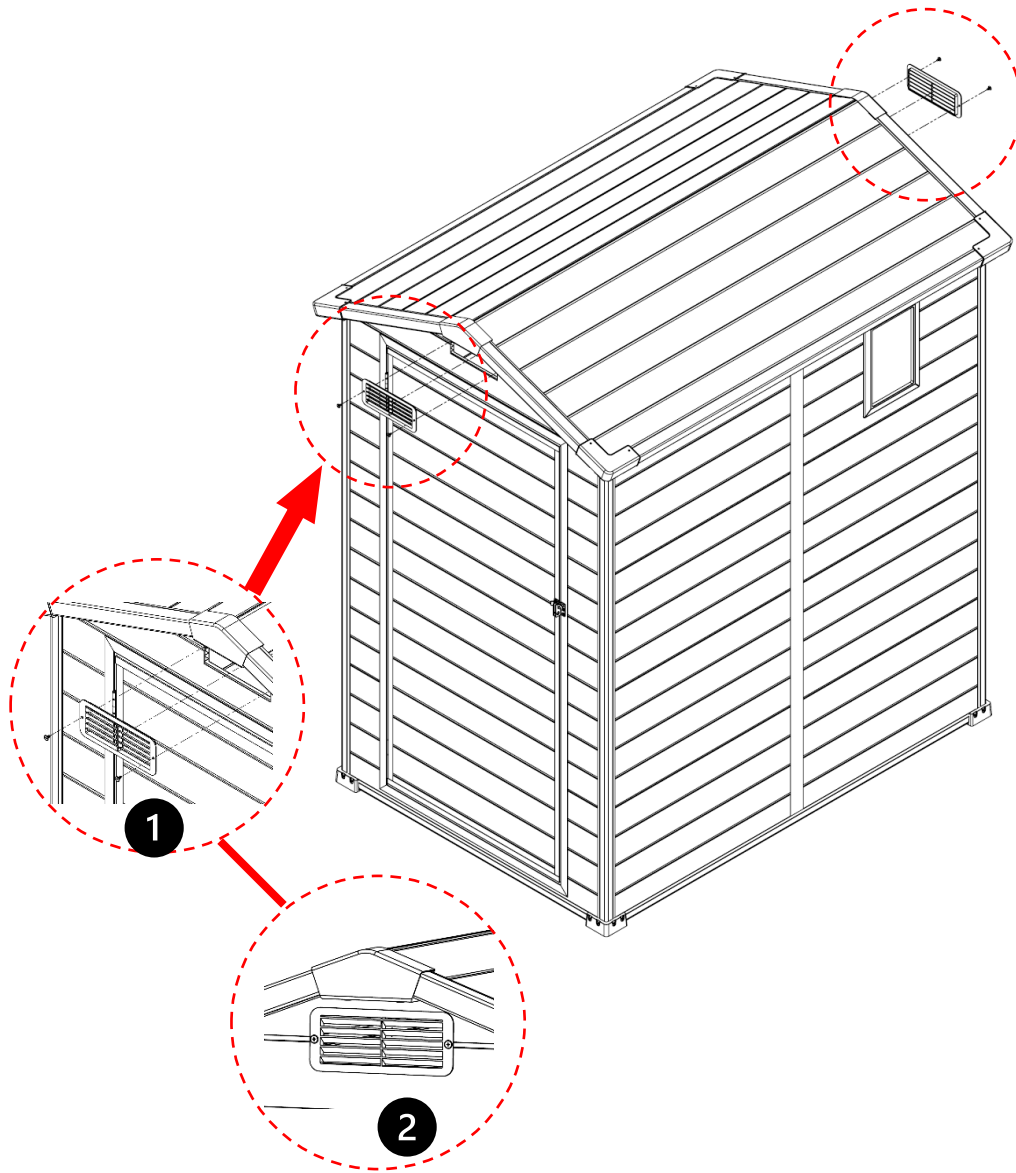

4PC



ST4.2*12

1PC

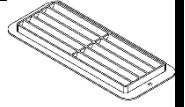

WD-02