

# ASSEMBLY INSTRUCTIONS

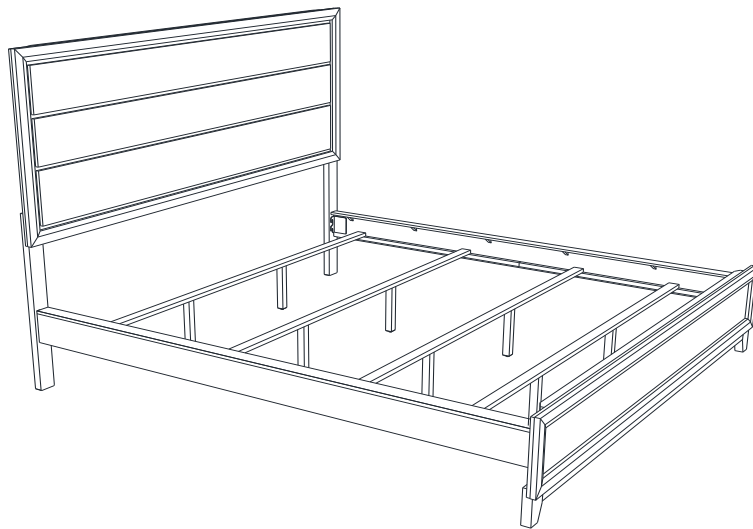

*Fine Furniture for every stage of life*

**California King Bed**

REVISION 0 : 01/18/2021  
REVISION 1 : 07/12/2023

**PAGE 1 OF 4**

# ASSEMBLY INSTRUCTIONS

## ASSEMBLY TIPS:

1. Remove hardware from box and sort by size.
2. Please check to see that all hardware and parts are present prior to start of assembly.
3. Please follow attached instructions in the same sequence as numbered to assure fast & easy assembly.



### WARNING!

1. Don't attempt to repair or modify parts that are broken or defective. Please contact the store immediately.
2. This product is for home use only and not intended for commercial establishments.









**ASSEMBLY TIME**



**20 MINUTES**

## PARTS IDENTIFICATION

### B1 (BOX 1)



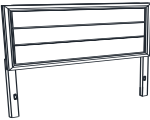

A	HEADBOARD PANEL		1PC	D	LEFT HEADBOARD LEG		1PC
B	FOOTBOARD		1PC	E	BED SLAT		4PCS
C	RIGHT HEADBOARD LEG		1PC	F	BED SLAT SUPPORT WITH LEVELER		8PCS

### B2 (BOX 2)

G	BED RAIL		2PCS				
HB	HEADBOARD COMPLETE		1PC	B	FOOTBOARD		1PC

## HARDWARE IDENTIFICATION

### Z-B1 (BOX 1) - HARDWARE PACK IS LOCATED

1	BOLT (M6 x 30mm - BLK)		6PCS	4	SMALL ALLEN WRENCH (M4 x 60mm - BLK)		1PC
2	LOCK WASHER (1/4" - BLK)		6PCS	5	BIG ALLEN WRENCH (M5 x 65mm - BLK)		1PC
3	FLAT WASHER (1/4"ID x 13mm - BLK)		6PCS				

### Z-B2 (BOX 2) - HARDWARE PACK IS LOCATED

6	PAN HEAD SCREW (M3.5 x 16mm - BLK)		16PCS	7	L-BRACKET		8PCS
---	---------------------------------------	---	-------	---	-----------	---	------

### NOTE:

Phillips head screw driver is required in the assembly process; however, manufacturer does not provide this item.

# ASSEMBLY INSTRUCTIONS

## STEP 1

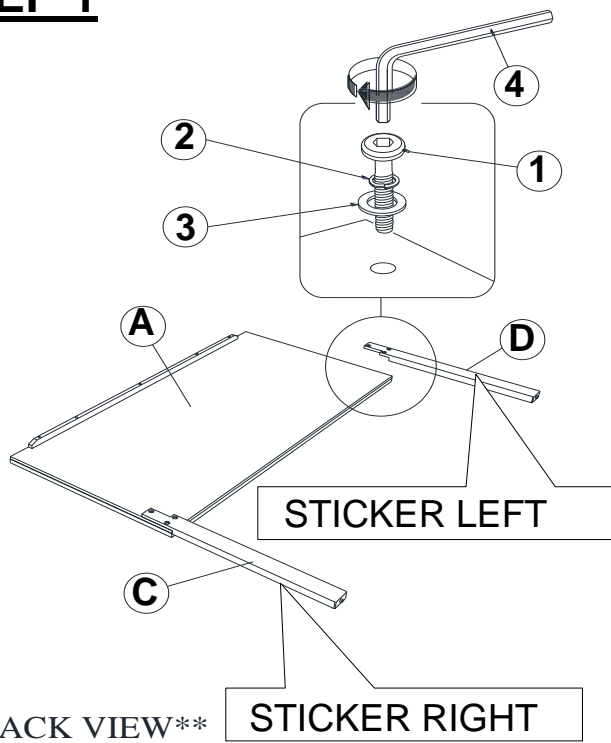

Note: Please take note of the marking sticker (L & R) on the headboard legs.

## STEP 2

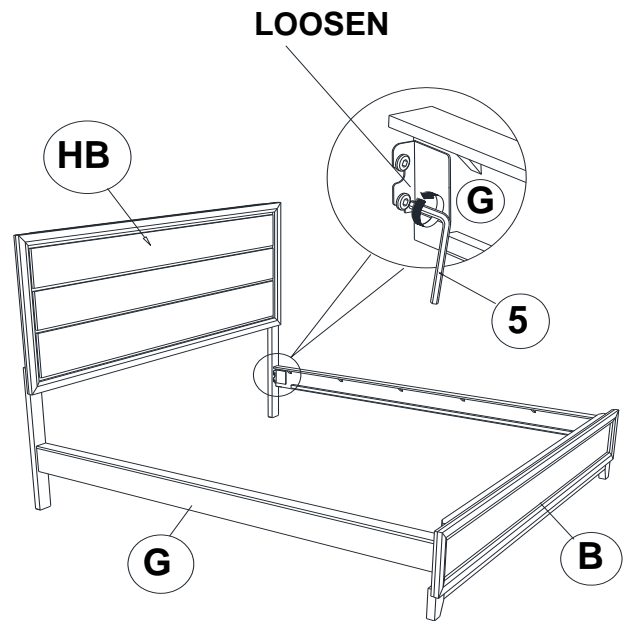

## STEP 3

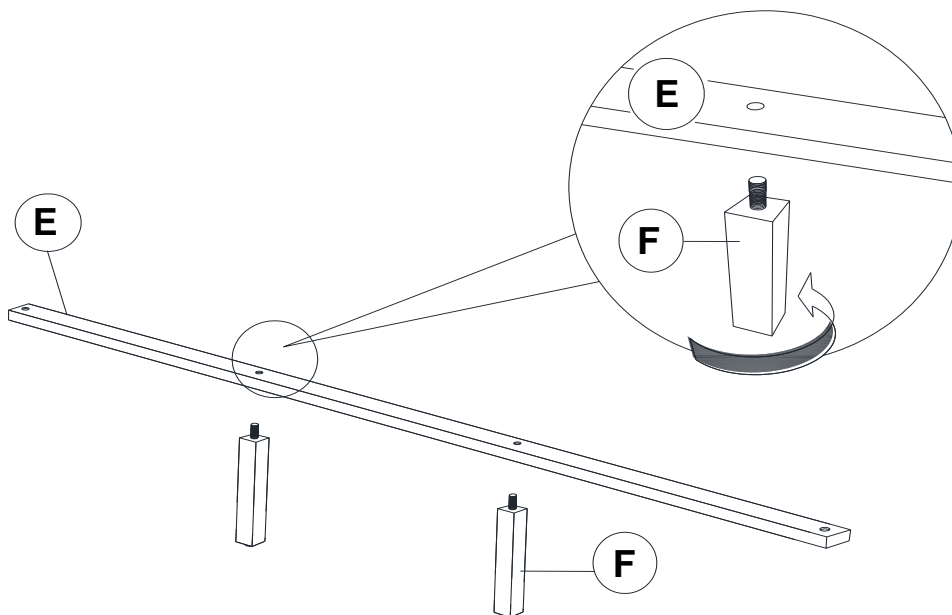

# ASSEMBLY INSTRUCTIONS

## STEP 4

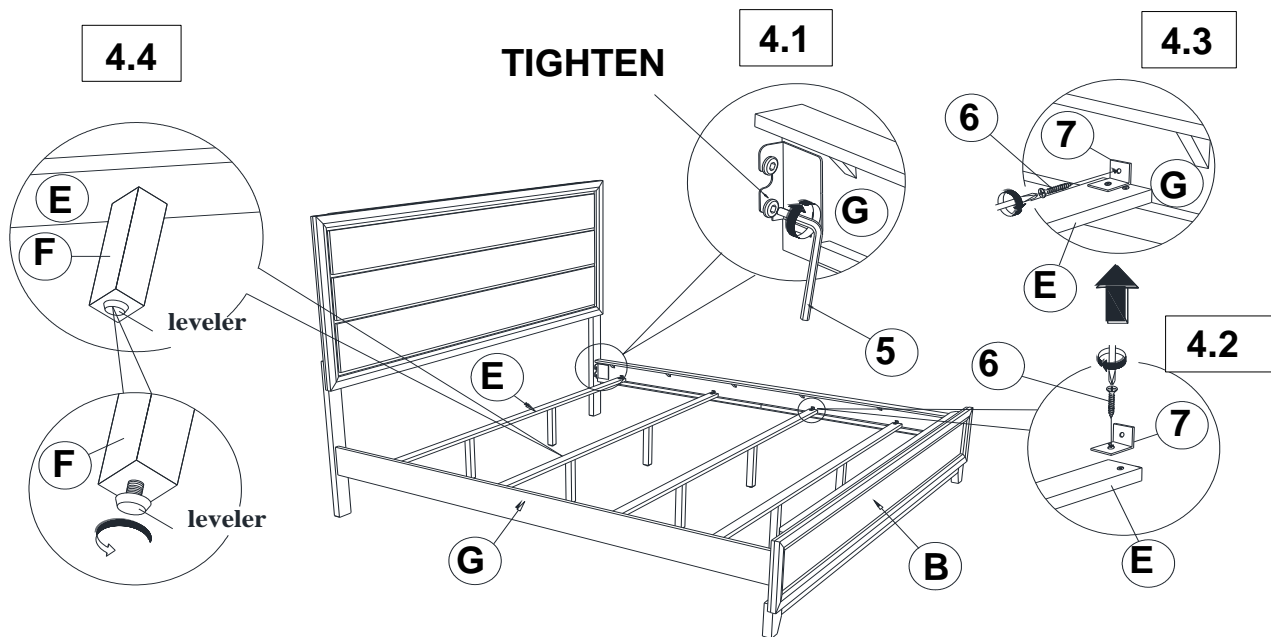

## STEP 5 COMPLETE

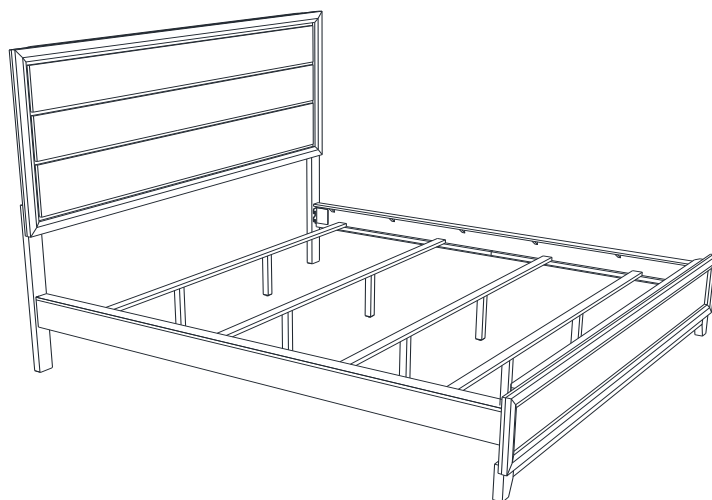

Inner Size : 76.75"W X 86.00"D

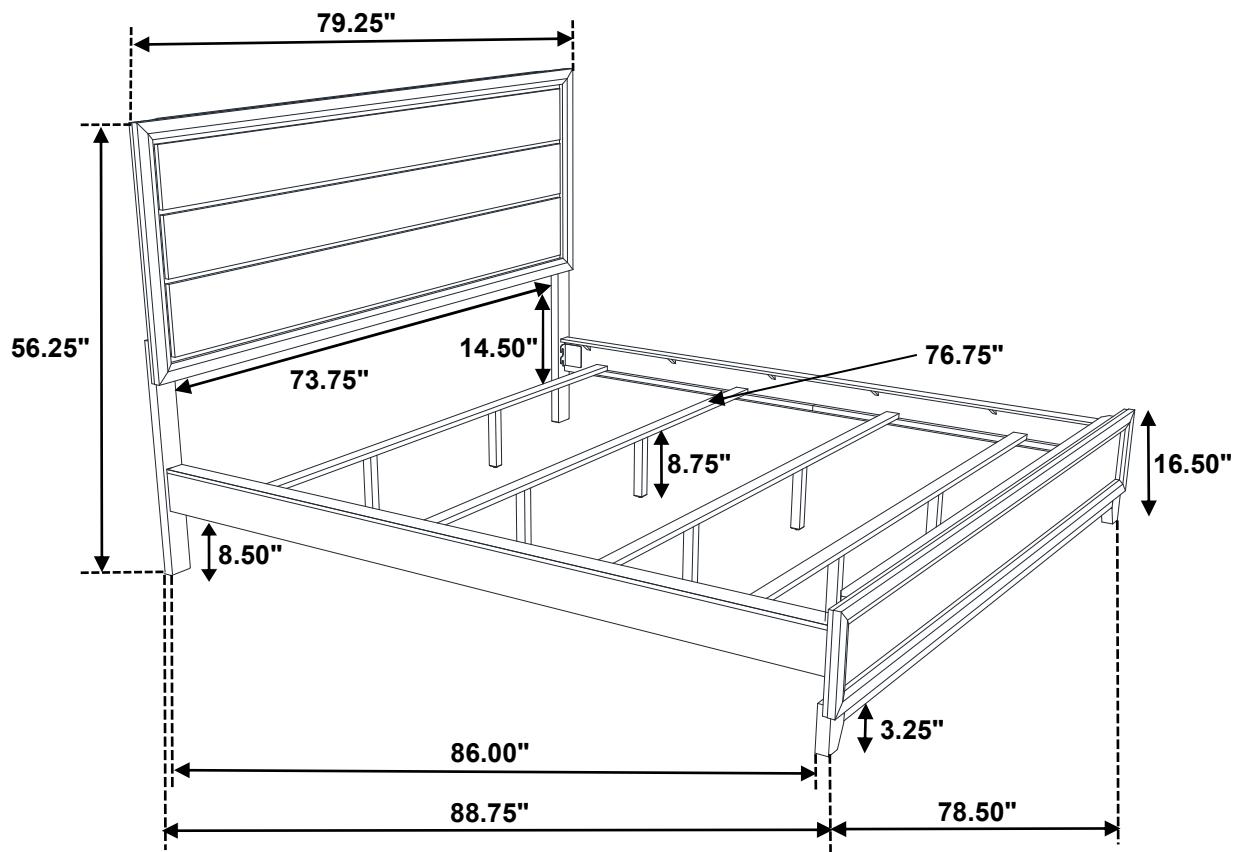

Note : Dimension tolerance  $\pm 5\%$

# ASSEMBLY INSTRUCTIONS



*Fine Furniture for every stage of life*

**Nightstand**

REVISION 0 : 10/16/2017  
REVISION 1 : 12/26/2017  
REVISION 2 : 08/09/2018  
REVISION 3 : 01/02/2019  
REVISION 4 : 12/13/2019

# ASSEMBLY INSTRUCTIONS

## ASSEMBLY TIPS:

1. Remove hardware from box and sort by size.
2. Please check to see that all hardware and parts are present prior to start of assembly.
3. Please follow attached instructions in the same sequence as numbered to assure fast & easy assembly.



### WARNING!

1. Don't attempt to repair or modify parts that are broken or defective. Please contact the store immediately.
2. This product is for home use only and not intended for commercial establishments.



ASSEMBLY TIME

5 MINUTES

## PARTS IDENTIFICATION

A NIGHTSTAND

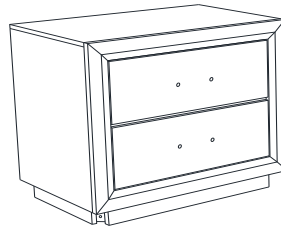

1PC

B LEG



4PCS

## HARDWARE IDENTIFICATION

1 BOLT  
(M6 x 50mm - BLK)



4PCS

2 LOCK WASHER  
(1/4" - BLK)



4PCS

3 FLAT WASHER  
(1/4" ID x 19mm - BLK)



4PCS

4 ALLEN WRENCH  
(M4 x 60mm - BLK)



1PC

### NOTE:

Phillips head screw driver is required in the assembly process; however, manufacturer does not provide this item.

# ASSEMBLY INSTRUCTIONS

## STEP 1

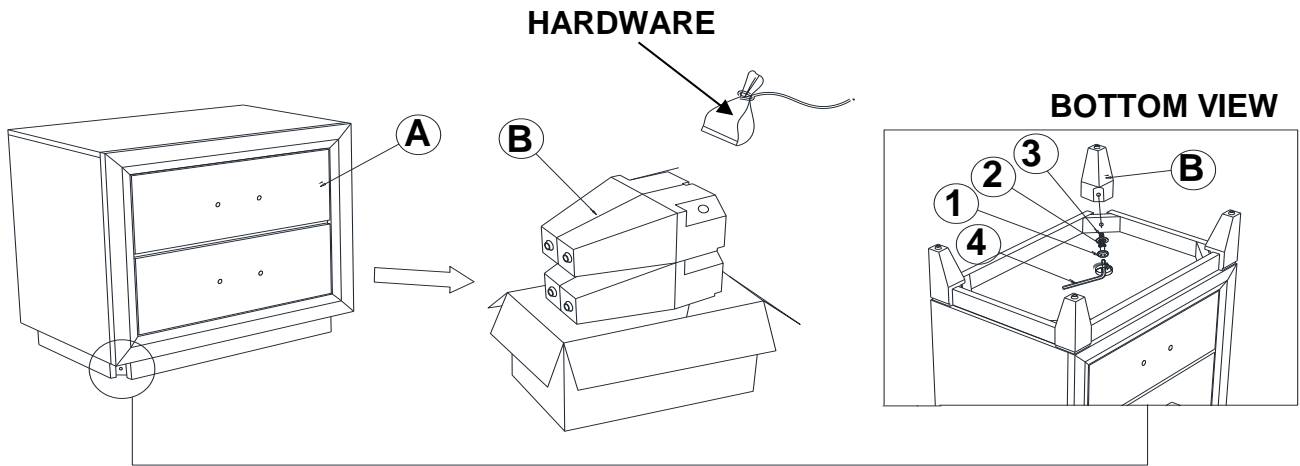

## STEP 2

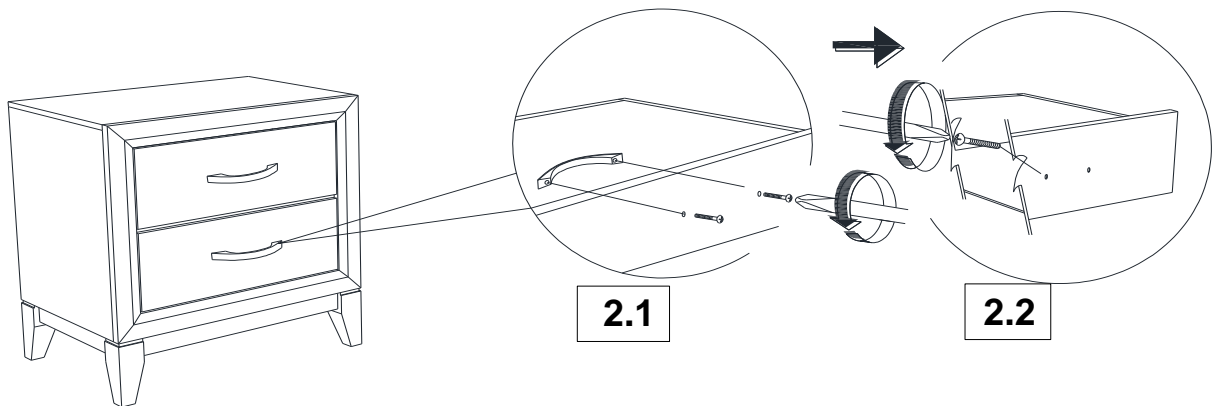

## STEP 3 **COMPLETE**

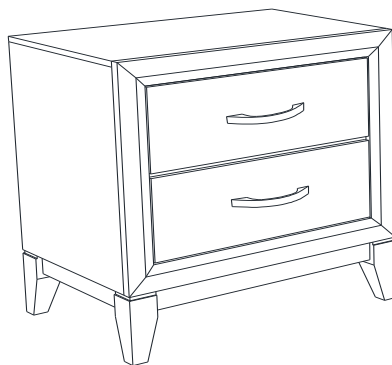

**Inner Size of Drawer : 17.00"W x 12.50"D x 4.00"H x 0.25"T**

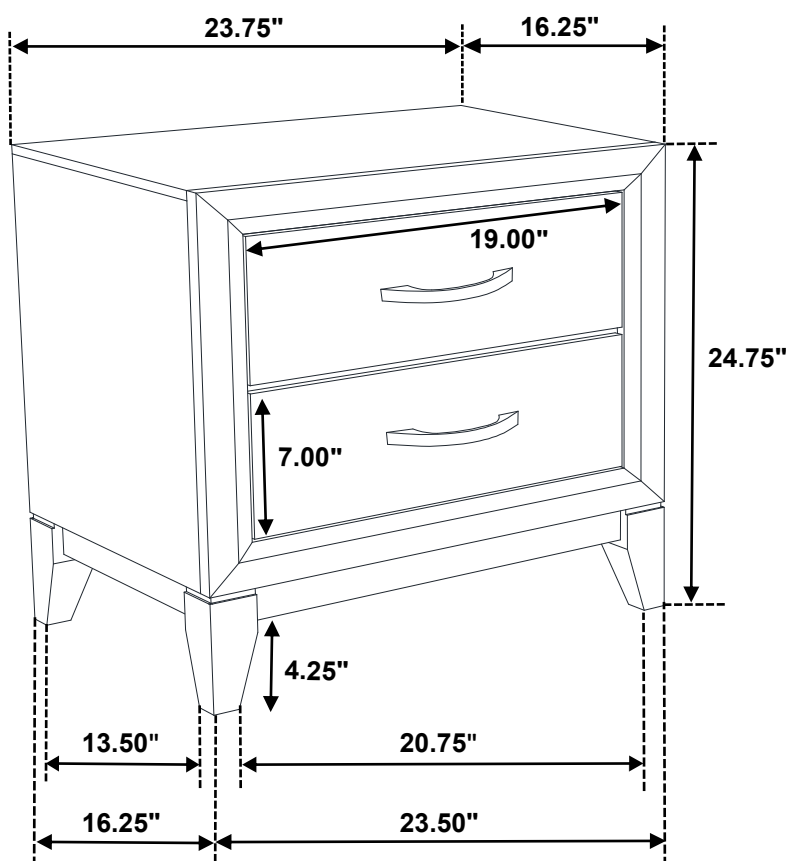

**Note : Dimension tolerance  $\pm 5\%$**

# ASSEMBLY INSTRUCTIONS



*Fine Furniture for every stage of life*

**Dresser**

REVISION 0 : 10/16/2017  
REVISION 1 : 12/26/2017  
REVISION 2 : 08/09/2018  
REVISION 3 : 01/02/2019  
REVISION 4 : 12/13/2019

# ASSEMBLY INSTRUCTIONS

## ASSEMBLY TIPS:

1. Remove hardware from box and sort by size.
2. Please check to see that all hardware and parts are present prior to start of assembly.
3. Please follow attached instructions in the same sequence as numbered to assure fast & easy assembly.



### WARNING!

1. Don't attempt to repair or modify parts that are broken or defective. Please contact the store immediately.
2. This product is for home use only and not intended for commercial establishments.



ASSEMBLY TIME

5 MINUTES

## PARTS IDENTIFICATION

A DRESSER 1PC

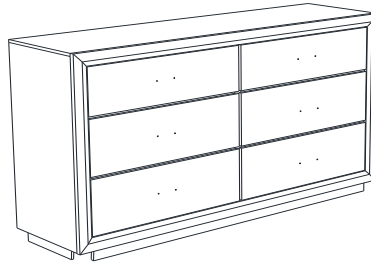

B LEG 4PCS



C CENTER SUPPORT LEG WITH LEVELER 1PC



## HARDWARE IDENTIFICATION

1 BOLT (M6 x 50mm - BLK) 4PCS

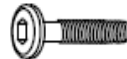

2 LOCK WASHER (1/4" - BLK) 4PCS



3 FLAT WASHER (1/4" ID x 19mm - BLK) 4PCS



4 ALLEN WRENCH (M4 x 60mm - BLK) 1PC



### NOTE:

Phillips head screw driver is required in the assembly process; however, manufacturer does not provide this item.

# ASSEMBLY INSTRUCTIONS

## STEP 1

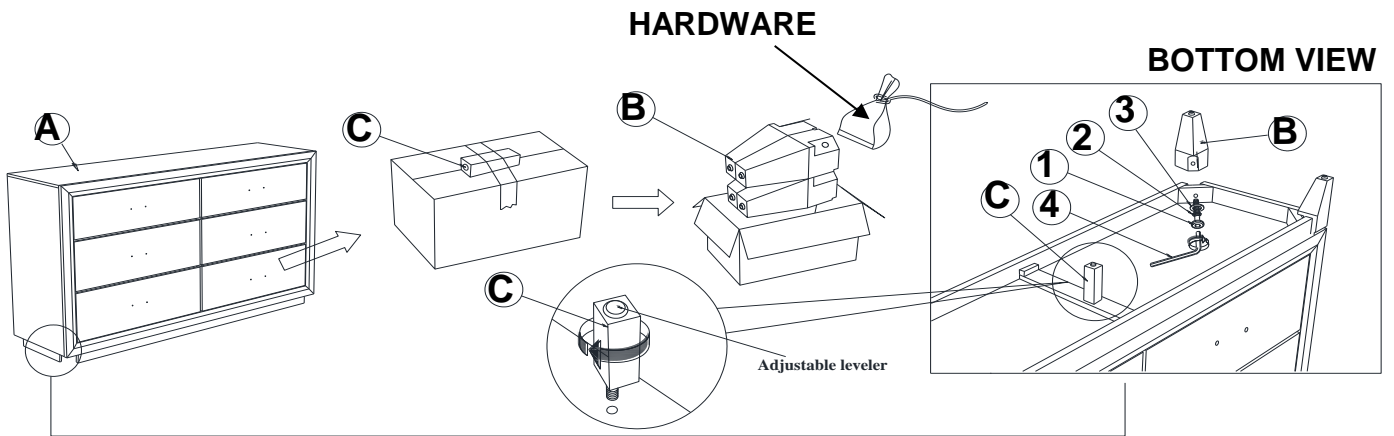

## STEP 2

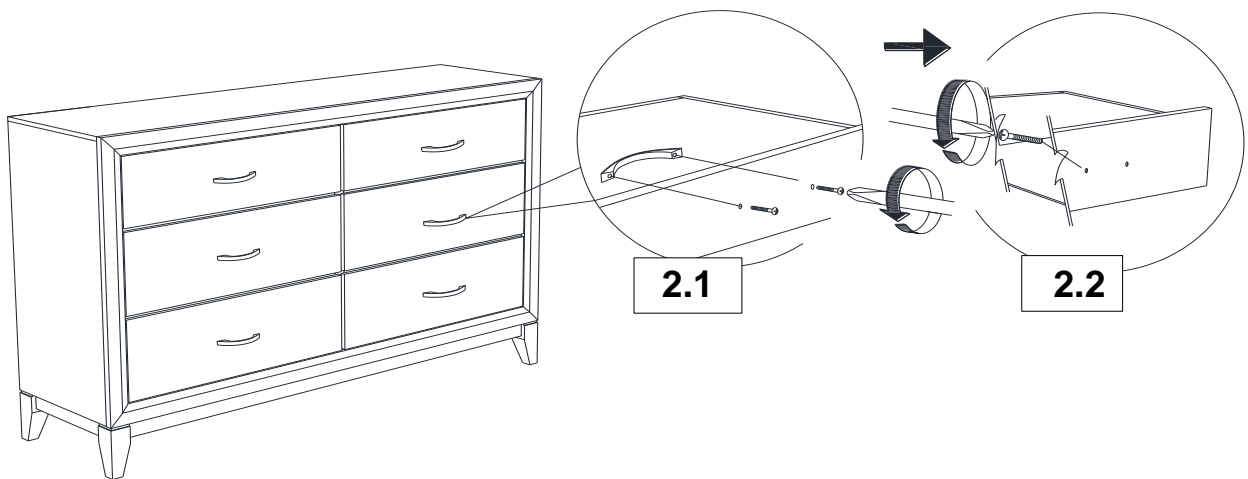

## STEP 3 **COMPLETE**



**Inner Size of Drawer : 23.25"W x 12.50"D x 5.00"H x 0.25"H**

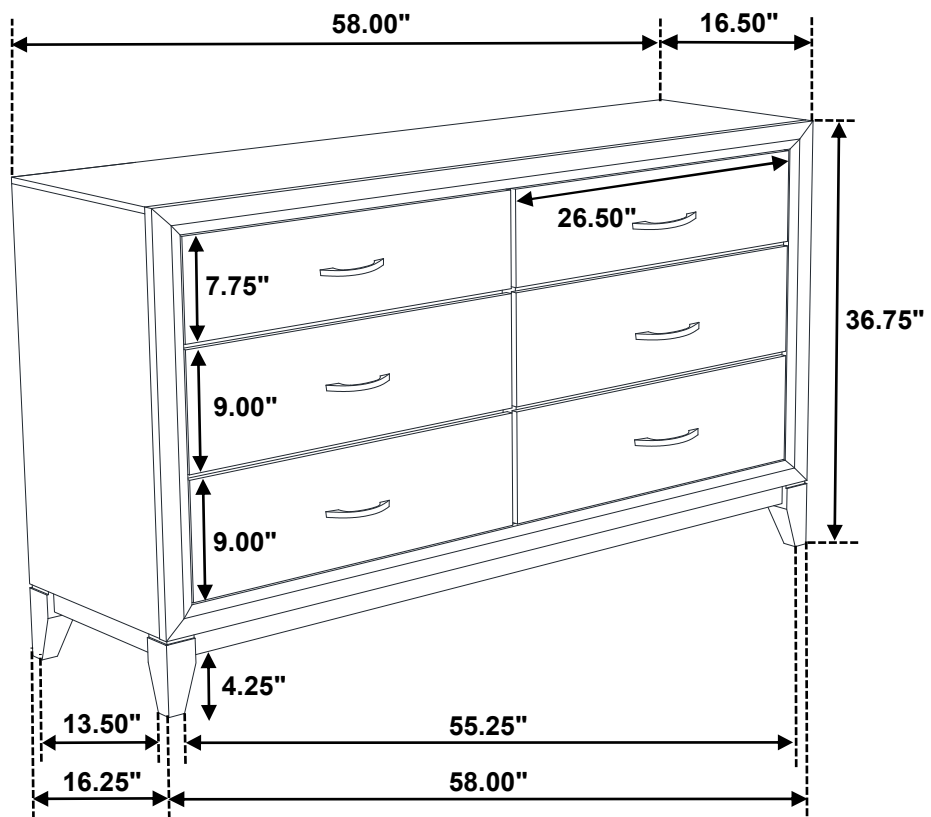

**Note : Dimension tolerance  $\pm 5\%$**

# ASSEMBLY INSTRUCTIONS



*Fine Furniture for every stage of life*

**Mirror**

REVISION 0 : 10/16/2017  
REVISION 1 : 08/09/2018  
REVISION 2 : 08/29/2018  
REVISION 3 : 01/02/2019  
REVISION 4 : 12/13/2019

# ASSEMBLY INSTRUCTIONS

## ASSEMBLY TIPS:

1. Remove hardware from box and sort by size.
2. Please check to see that all hardware and parts are present prior to start of assembly.
3. Please follow attached instructions in the same sequence as numbered to assure fast & easy assembly.



### WARNING!

1. Don't attempt to repair or modify parts that are broken or defective. Please contact the store immediately.
2. This product is for home use only and not intended for commercial establishments.



ASSEMBLY TIME

10 MINUTES

## PARTS IDENTIFICATION

A MIRROR

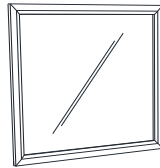

1PC

B DRESSER

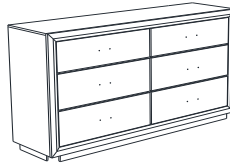

1PC

C MIRROR SUPPORT  
(PACK WITH MIRROR)

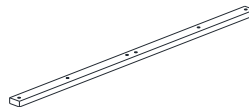

2PCS

## HARDWARE IDENTIFICATION

1 FLAT HEAD SCREW  
(M4 x 32mm - RBW)



12PCS

### NOTE:

Phillips head screw driver is required in the assembly process; however, manufacturer does not provide this item.



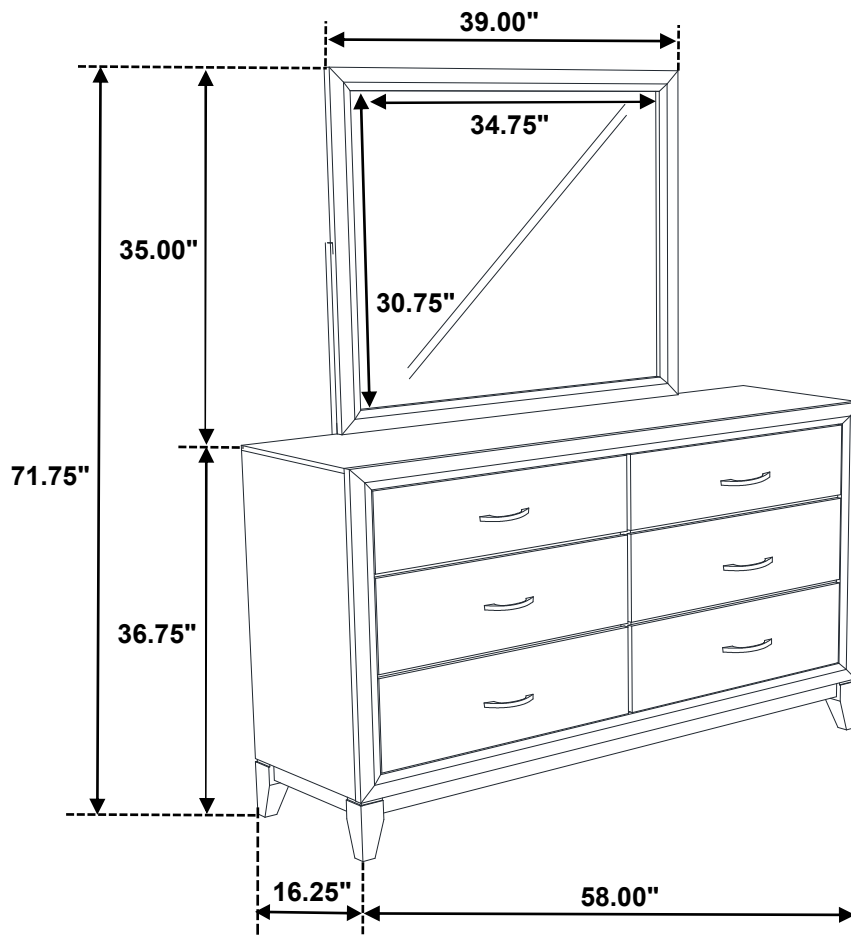

**Note : Dimension tolerance  $\pm 5\%$**