

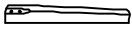

**Do not tighten screws until completely assembled**



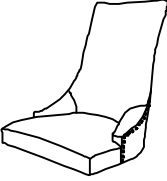

# ASSEMBLY INSTRUCTION

Chair

## Parts

NO.	Picture	Description	Side QTY	QTY
A		FRONT LEG	40*40*410mm	2
B		REAR LEG	40*30*410mm	2
C		CHAIR BODY	22.25"W * 26"D * 25.25"H	1

## Hardware

NO.	Picture	Description	Side QTY	QTY
D		Allen Key	Ø5/16*65mm	1
E		Bolt	Ø5/16*50mm	8
F		Flat Washer	Ø5/16*22mm	8
G		Spring Washer	Ø5/16*12mm	8

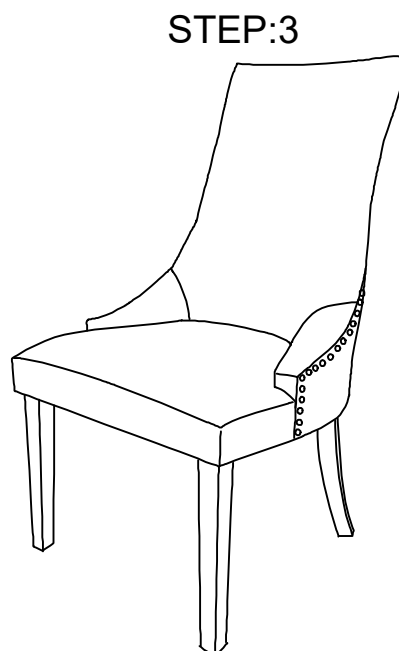
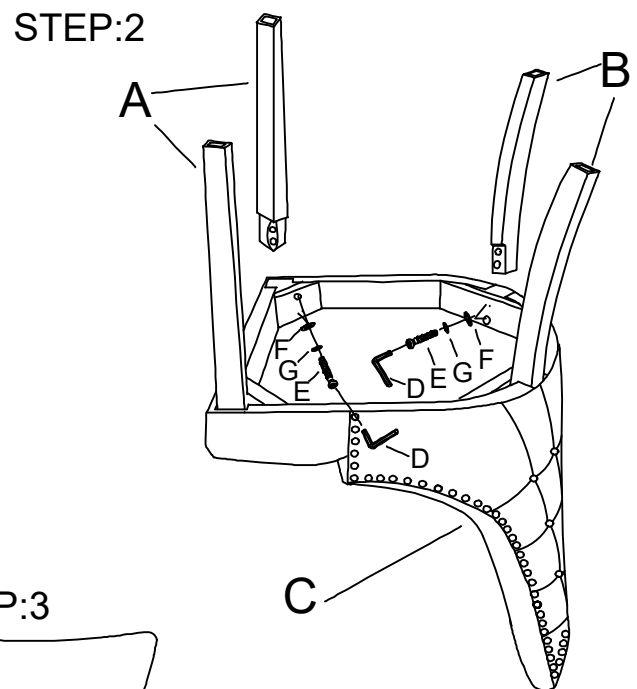
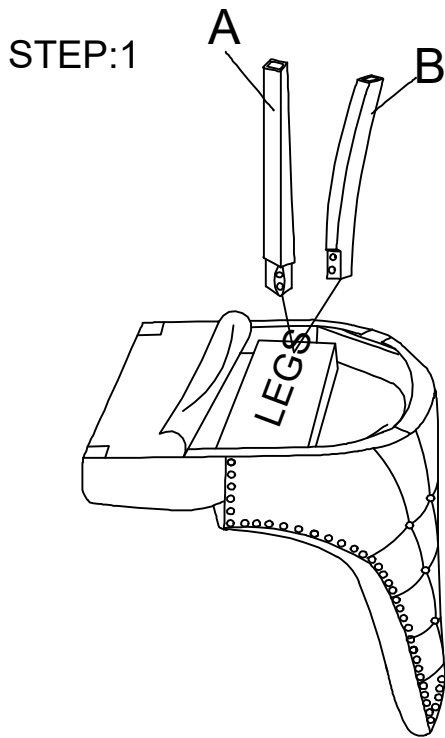

Overall Size: 22.25"W\*26"D\*39"H

**Do not tighten screws until completely assembled**