

ASSEMBLY INSTRUCTIONS

IMPORTANT NOTE

****PLACE ALL PARTS ON A CLEAN AND SMOOTH SURFACE SUCH AS A RUG OR CARPET TO AVOID THE PARTS FROM BEING SCRATCHED**

****BEFORE YOU BEGIN, KINDLY FOLLOW THE ASSEMBLY INSTRUCTIONS STEP BY STEP**



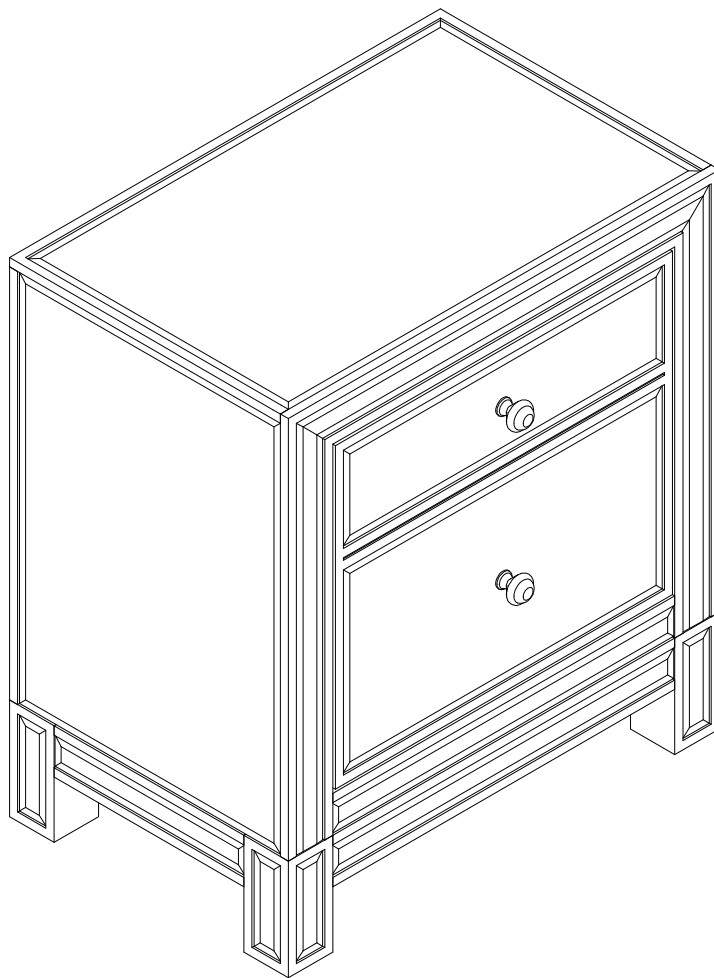

****DO NOT TIGHTEN ALL SCREWS AND BOLTS UNTIL THE CABINET IS FULLY SET-UP**

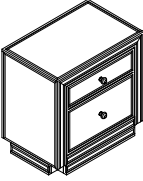

PLEASE DO NOT RETURN PRODUCT TO THE STORE

ASSEMBLY INSTRUCTIONS

CARTONS ONLY ONE / HARDWARE LIST

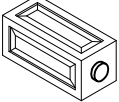
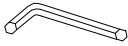
PART LISTS				HARDWARE LIST			
NO	DESCRIPTION	SKETCH	QTY	NO	DESCRIPTION	SKETCH	QTY
A	NIGHTSTAND		1 PC	1	BOLT Ø1/4*1-1/2"L		8 PCS
				2	WASHER Ø1/4*19mm		8 PCS
				3	SPRING WASHER Ø1/4*11		8 PCS
B	LEGS		4 PCS	4	ALLEN KEY M4*65mm		1 PC

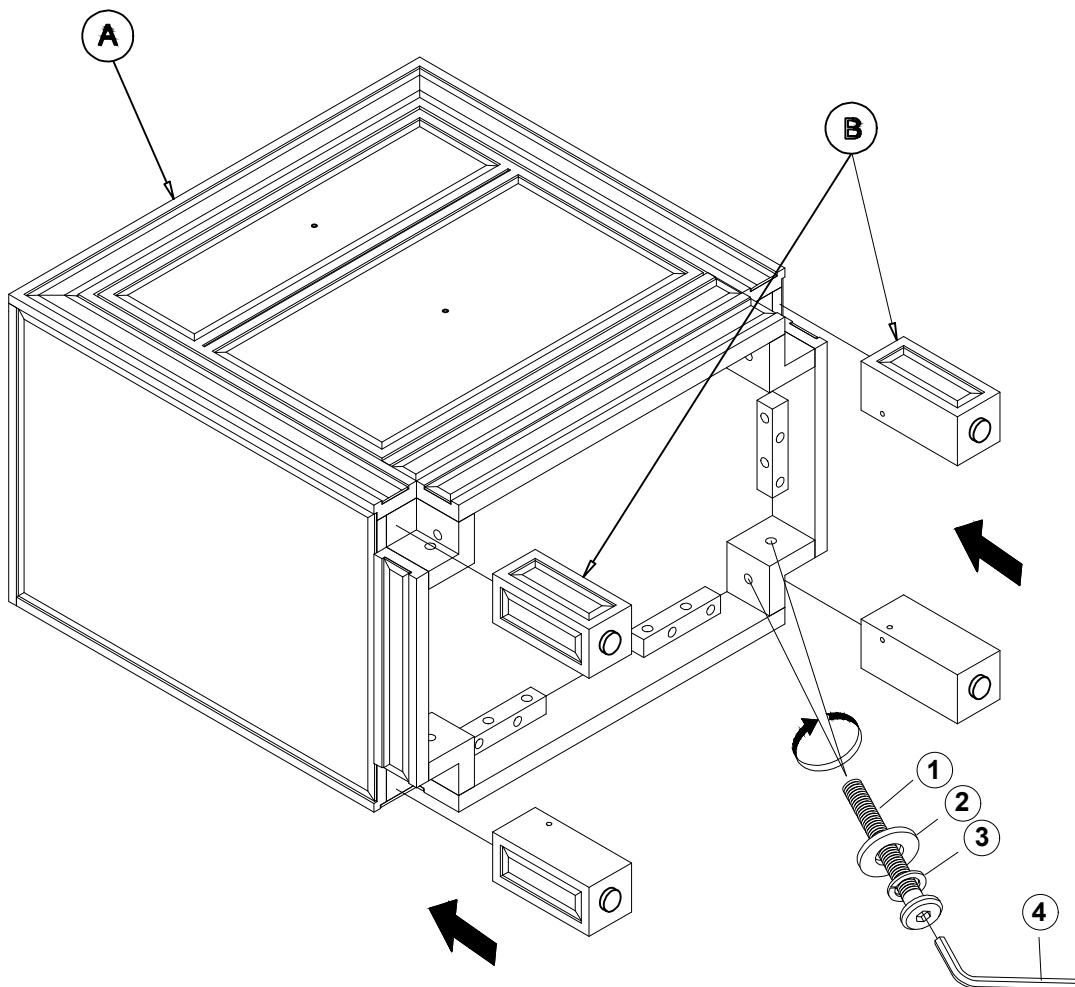

ASSEMBLY INSTRUCTIONS

