

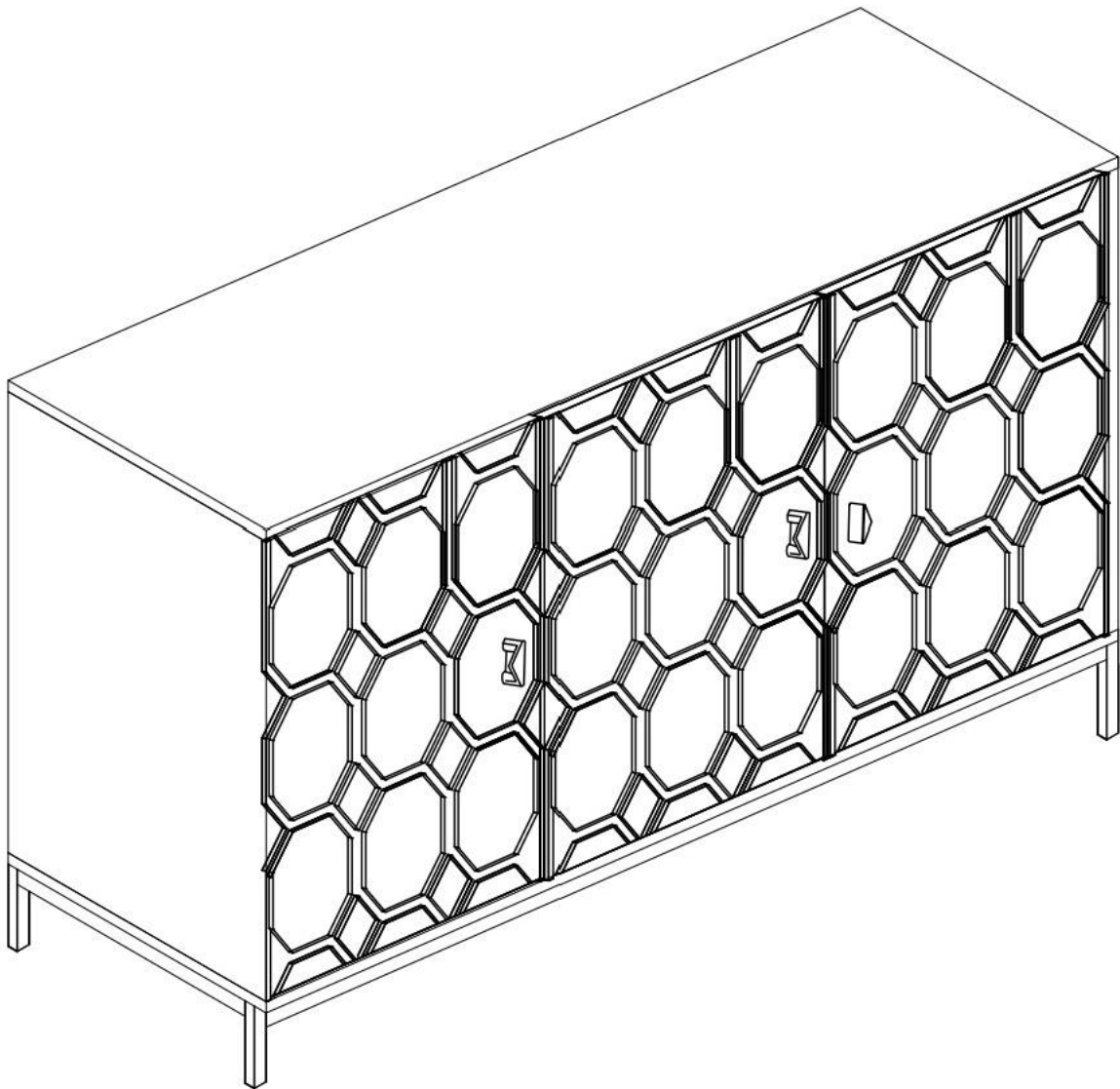

ASSEMBLY INSTRUCTIONS

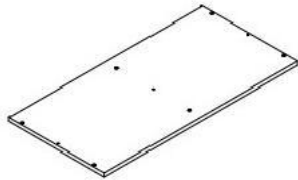

ASSEMBLY INSTRUCTIONS

Part List:

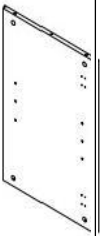
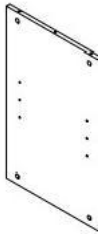
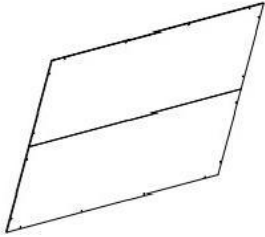



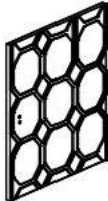
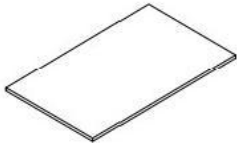
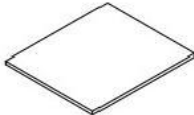
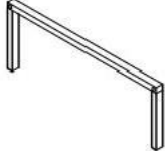
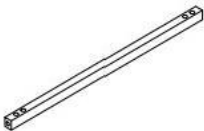



ITEM	DESCRIPTION	PART	QTY
1	Top panel		1
2	Bottom panel		1
3	Left side pane		1
4	Right side pane]		1
5	Middle side plate		1
6	Back panel		1

Part List:









ITEM	DESCRIPTION	PART	QTY
7	Left door		2
8	Right door		1
9	Adjustable movable plate (long)		
10	Adjustable movable plate (short)		1
11	Leg		2
12	Leg		2

ASSEMBLY INSTRUCTION

Hardware List:

ITEM	DESCRIPTION	PART	QTY
A	Camlock bolt		12
B	Camlock		12
C	Wooden dowel	 $\phi 6*30\text{mm}$	6
D	Bolt	 $\frac{1}{4}''*1\frac{1}{5}''$	10
E	Allen wrench		1
F	Bolt	 $\phi 1\frac{1}{4}''*1\frac{1}{2}''$	4
G	Handle		3
H	Machine screw	 $\phi 5\frac{3}{32}''*4\frac{1}{5}''$	6
I	Door hinge (big bend)		4

Hardware List:

ITEM	DESCRIPTION	PART	QTY
J	Round head screw	 $\phi 4*12\text{mm}$	36
K	Back screw	 $\phi 3*12\text{mm}$	20
L	Shelf support		8
M	Safety wall strap		2
N	Plastic anchor		2
O	Mounting screw	 $\phi 4*38\text{mm}$	2
P	Washer		2
Q	Door hinge (middle bend)		2

- *Required screwdriver & mallet, not included.
- *Before discarding packing materials, please check to make sure that all parts and hardware is present
- *Two people needed for assembly
- *Please follow the instructions closely; do not over tighten screws or bolts unless instructed.
- *After a few days from initial assembly, the product may have acclimated to the new environment. Please retighten the hardware.

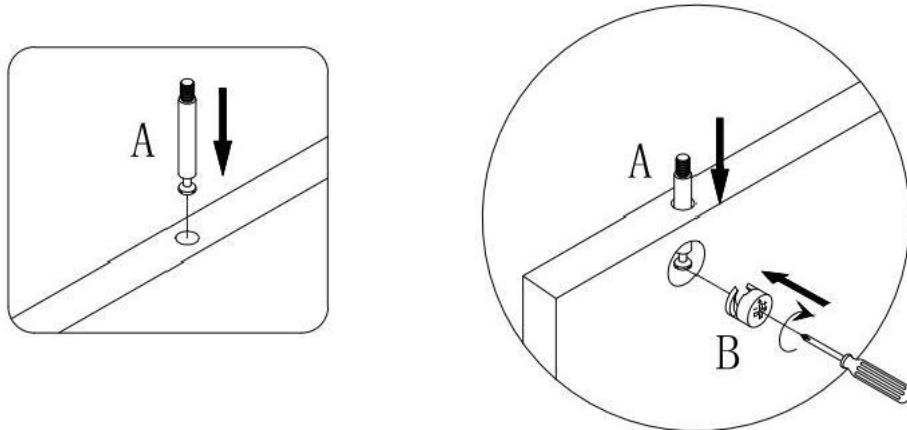

Guideline For Assembling of Cam Lock (A & B)



Screw camlock bolt (A) to wood part
 Do not assemble camlock (B) unless instructed
 To assemble camlock (B), ensure long side of the + is facing the bolt (A)
 before inserting into hole.

ASSEMBLY INSTRUCTION

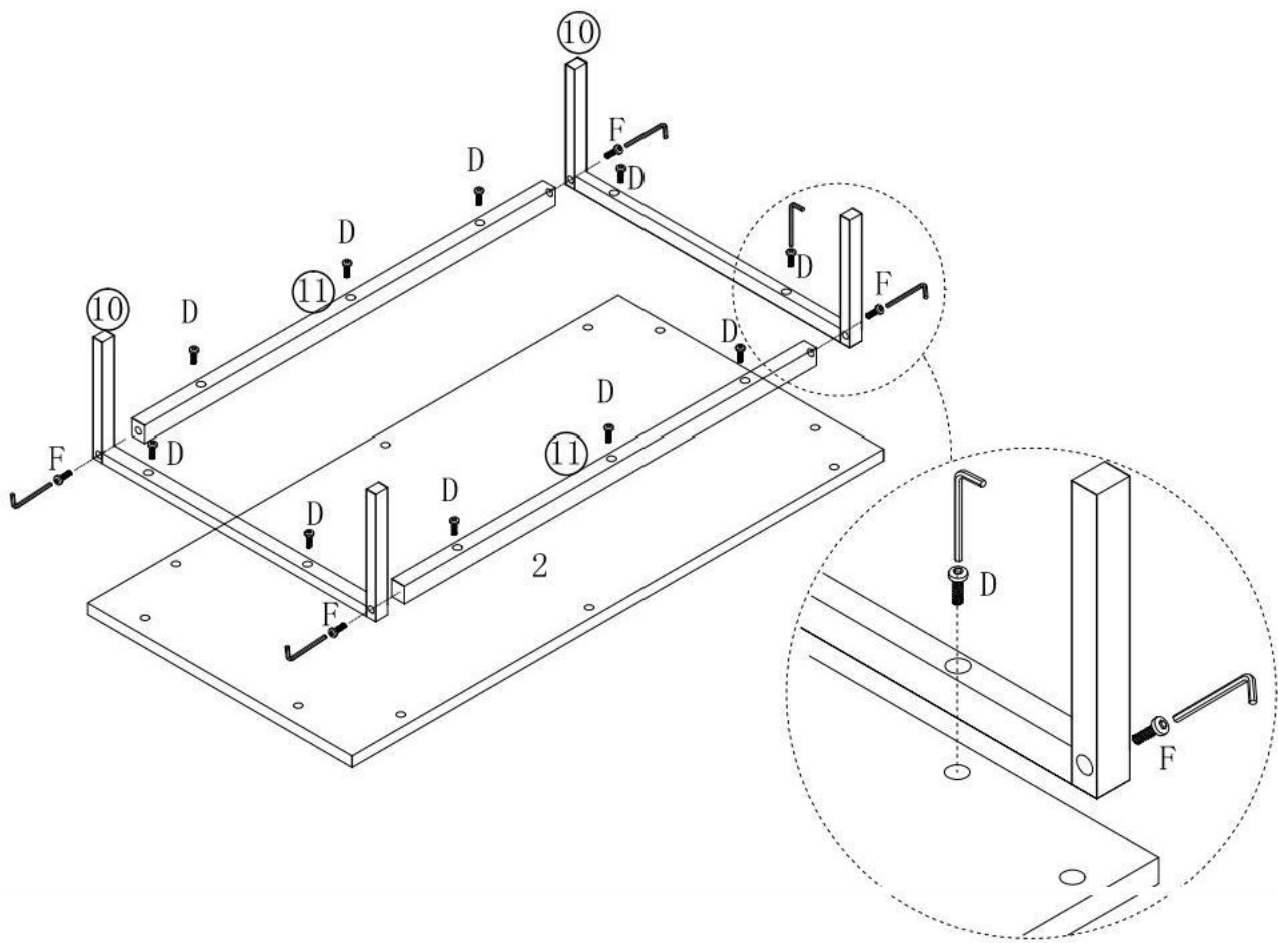

STEP 1

D:		10PCS
E:		1PC
F:		4PCS



ASSEMBLY INSTRUCTION

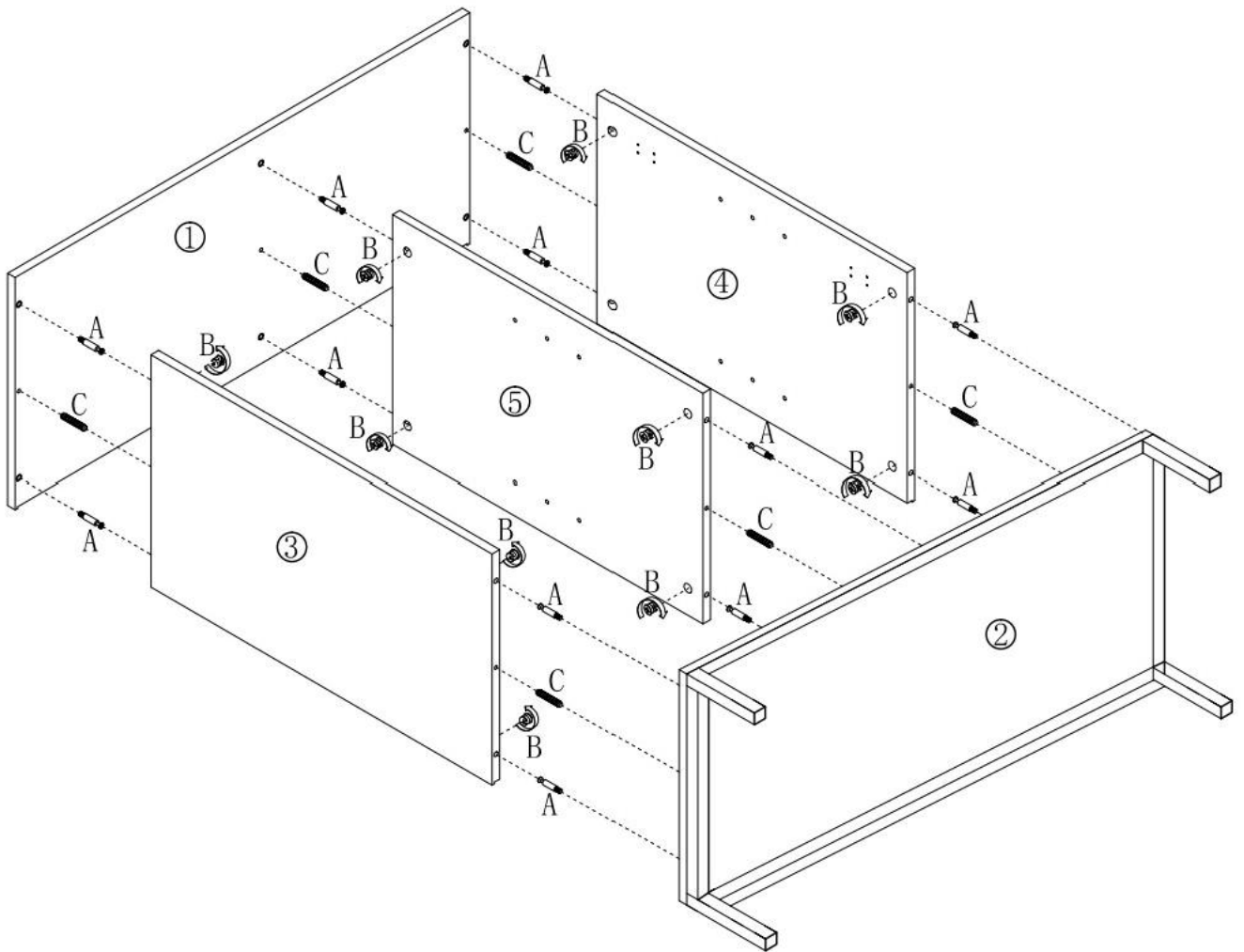

STEP 2

A:		12PCS
B:		12PCS
C:		6PCS





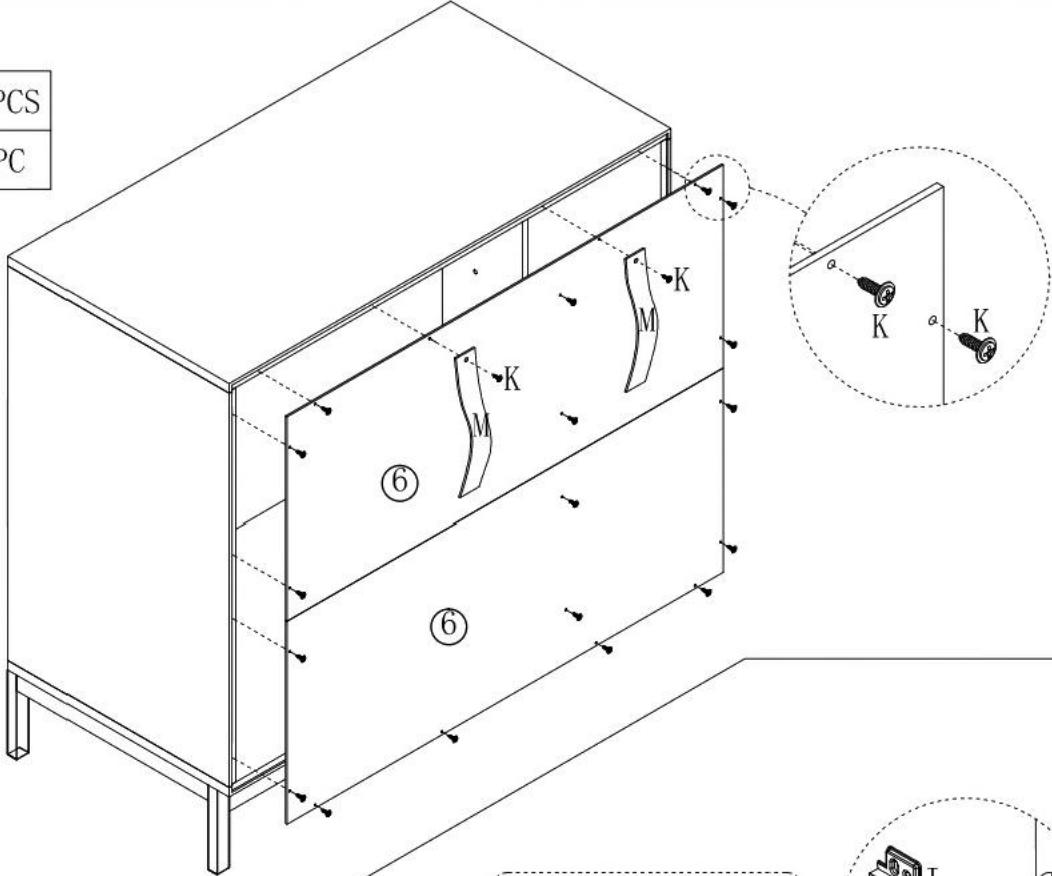

ASSEMBLY INSTRUCTION

STEP 3

K:		20PCS
M:		2PC



STEP 4

G:		3PCS
H:		6PCS
I:		4PCS
Q:		2PCS
J:		8PCS

Tip: Please note that the hinges of this door panel are mid-curved

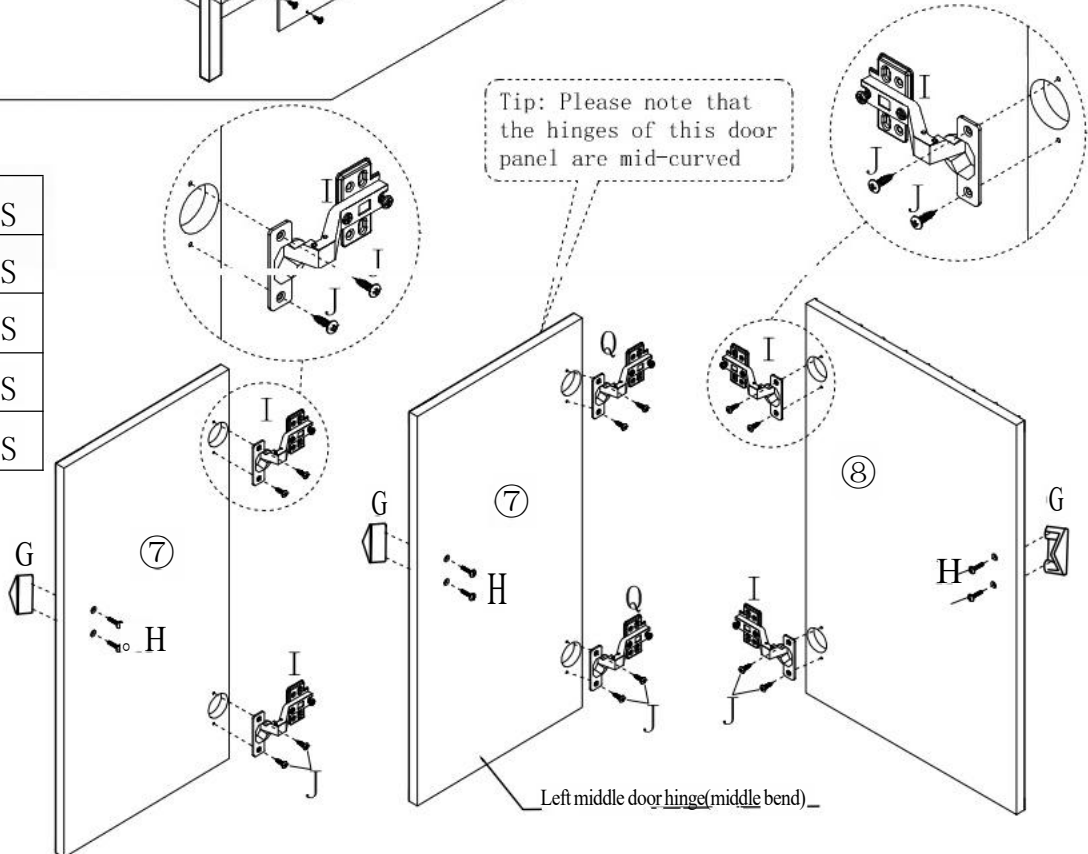

ASSEMBLY INSTRUCTION

STEP 5

J:  16PCS

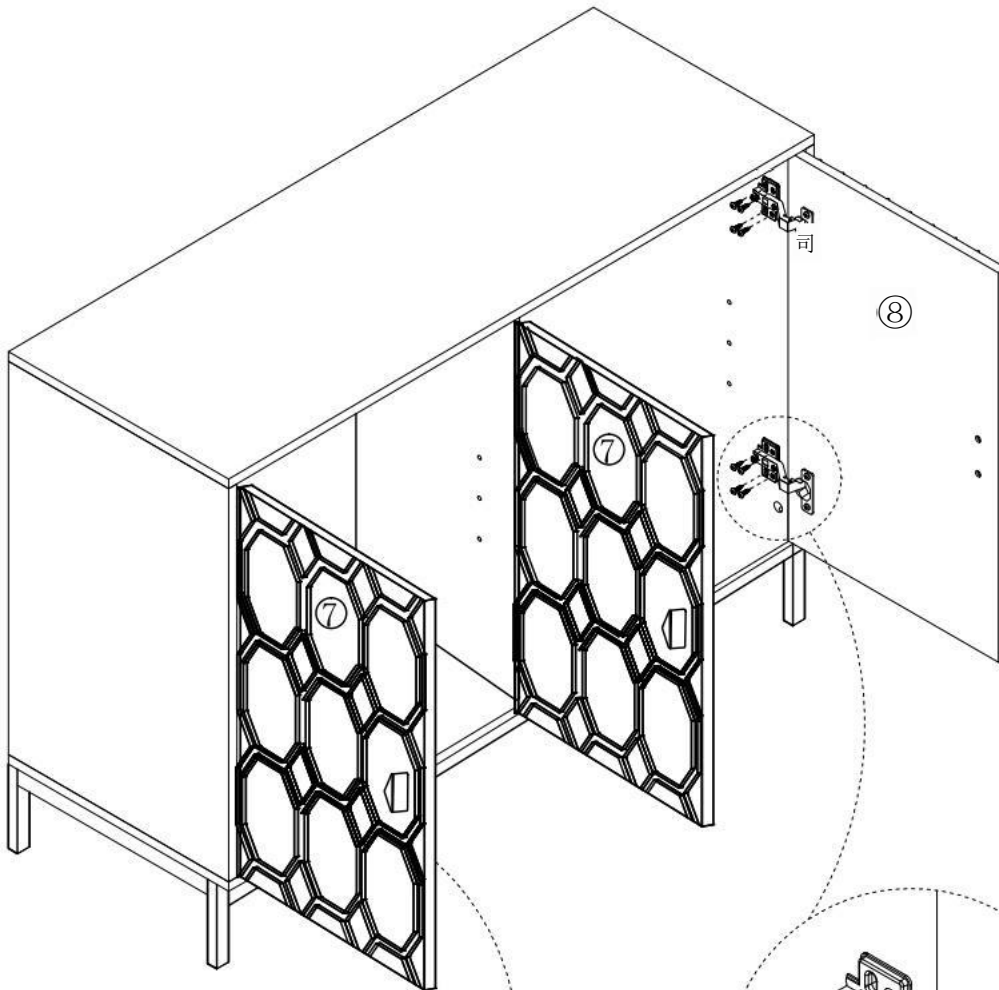

DOOR FITTING

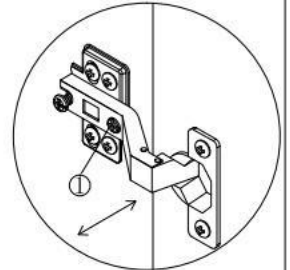

To adjust in width

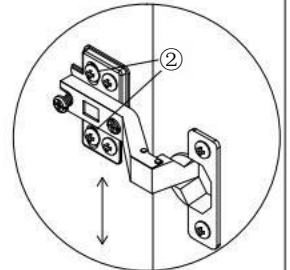

To adjust in height

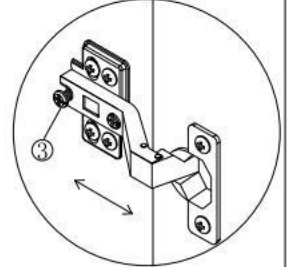

To adjust in depth

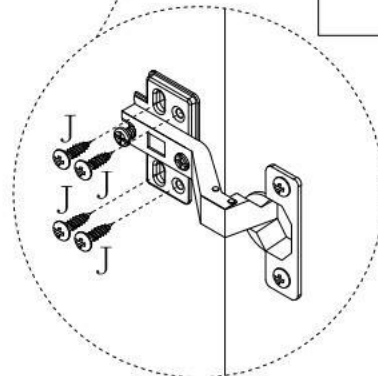
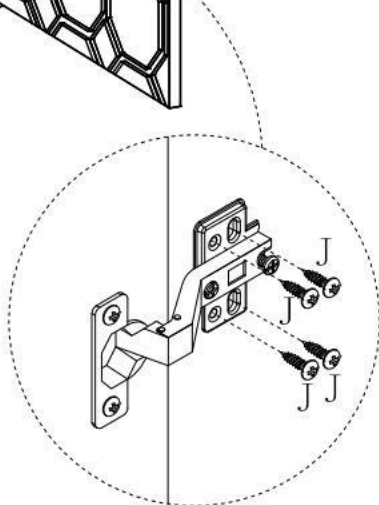

ASSEMBLY INSTRUCTION

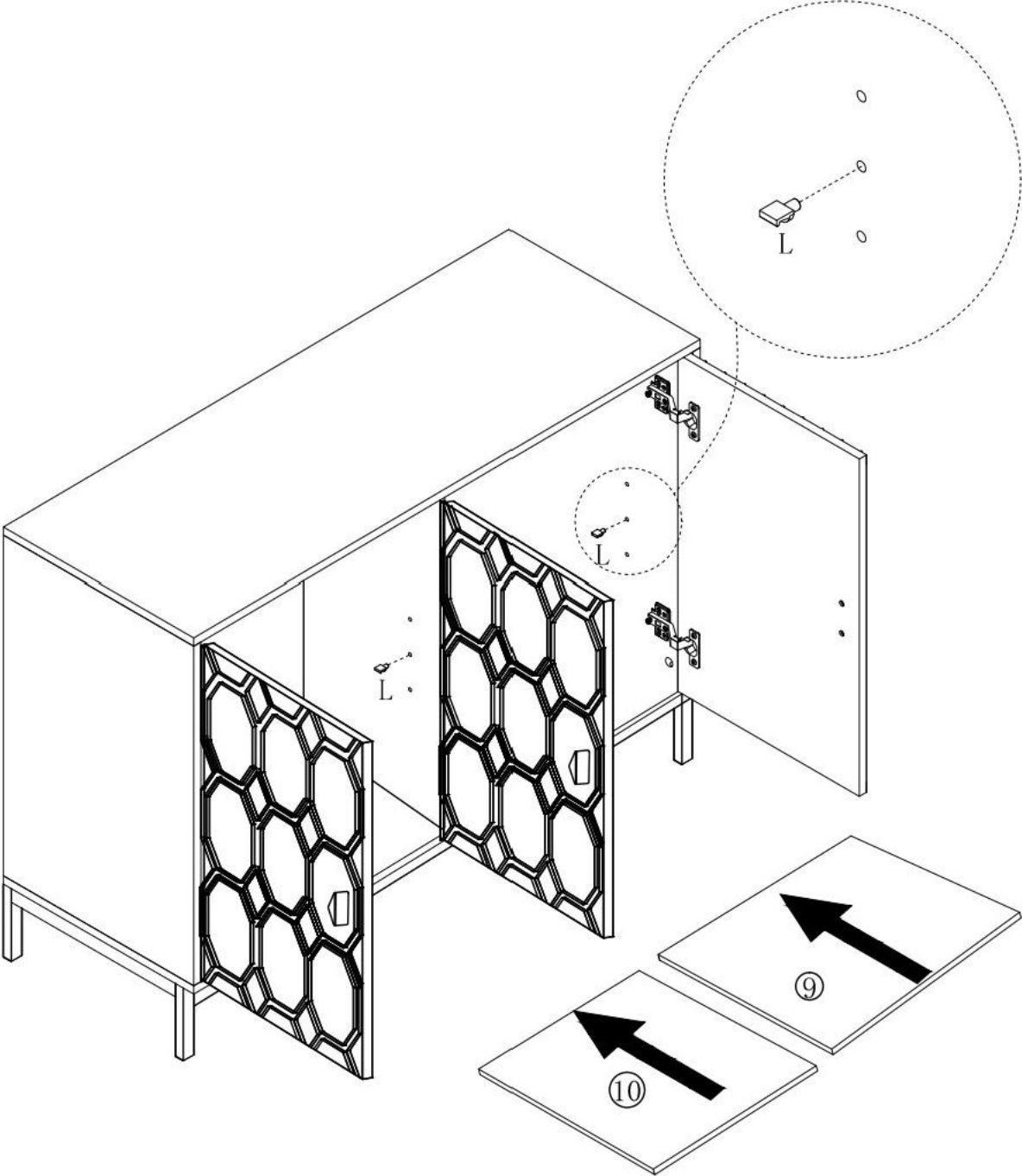

STEP 6

L:  8PCS



ASSEMBLY INSTRUCTION

STEP 7

N:		2PC
O:		2PC
P:		2PC

