

ASSEMBLY INSTRUCTIONS

PLEASE KEEP THIS FOR FUTURE REFERENCE

COMPUTER DESK

1.0 hr

APPROXIMATE ASSEMBLY TIME

1 PERSON ASSEMBLY



FLOOR AREA
2.0M X2.0M

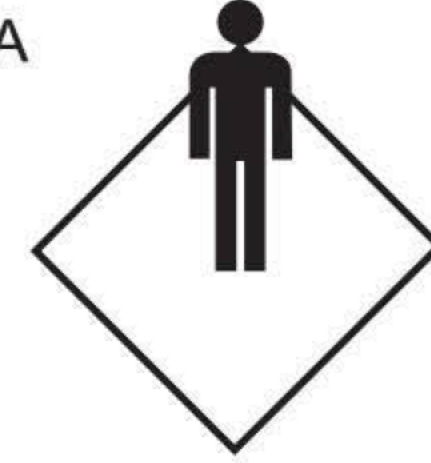

REQUIRED ASSEMBLY SPACE

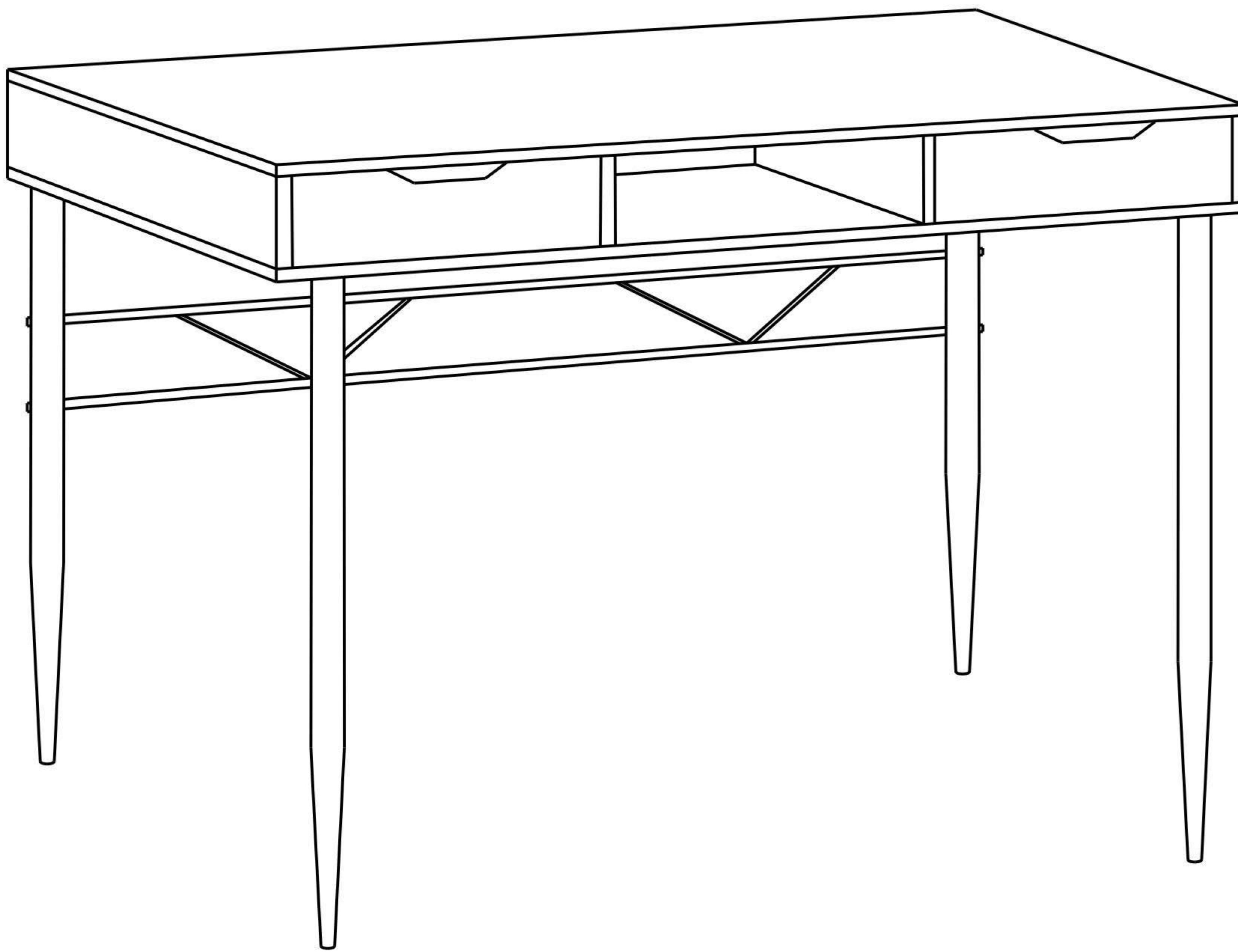

Top Tips before you start!

1. Please check that all parts are present before you start the assembly of your furniture.
2. For ease and speed of assembly, we recommend that before you commence each step of the assembly, that you identify all the parts required for that step.
3. For larger items, please ensure that you have sufficient space and people (as indicated on page 1) to assemble your product safely
4. We recommend that, where possible, all items are assembled near to the area in which they will be placed in use, to avoid moving the product unnecessarily once assembled.
5. For the protection of your furniture, particularly items of high gloss finish, we recommend that the product is placed on a protected surface during assembly to prevent any damage.
6. During assembly please take care not to over-tighten any fittings, as this may damage the product.
7. Do not use power tools to assemble any part of this item. Doing so can cause irreparable damage and invalidate the manufacturers warranty.

Care and Maintenance of your Furniture

- Please periodically check all fittings and re-tighten as necessary.
- Please do not sit or stand on this item.
- Never allow any kind of liquid to remain on your furniture, Absorption can cause wood to warp or finishes to de-laminate
- Please do not drag and pull your furniture.
- If the glass is chipped or broken, stop using the product and consult the manufacturer or supplier.
- Please do not place very hot or very cold items on the glass surface, unless adequately thick table mats are used to prevent such items from coming into contact with the glass.
- Please do not use the glass as a chopping surface. Do not strike the glass with hard or pointed items.
- When cleaning glass panels use a damp cloth or chamois leather with washing up liquid or soft soap, do not use washing powders or any other substances containing abrasives as these substances will scratch the glass.
- The glass used in this product is toughened and complies with BS EN 12150-1:2000, clauses 8.3 & 8.4

Never use furniture polish on this unit.

Clean with a damp cloth & warm soapy water - never use scourers or abrasive cleaners.

PARTS LIST

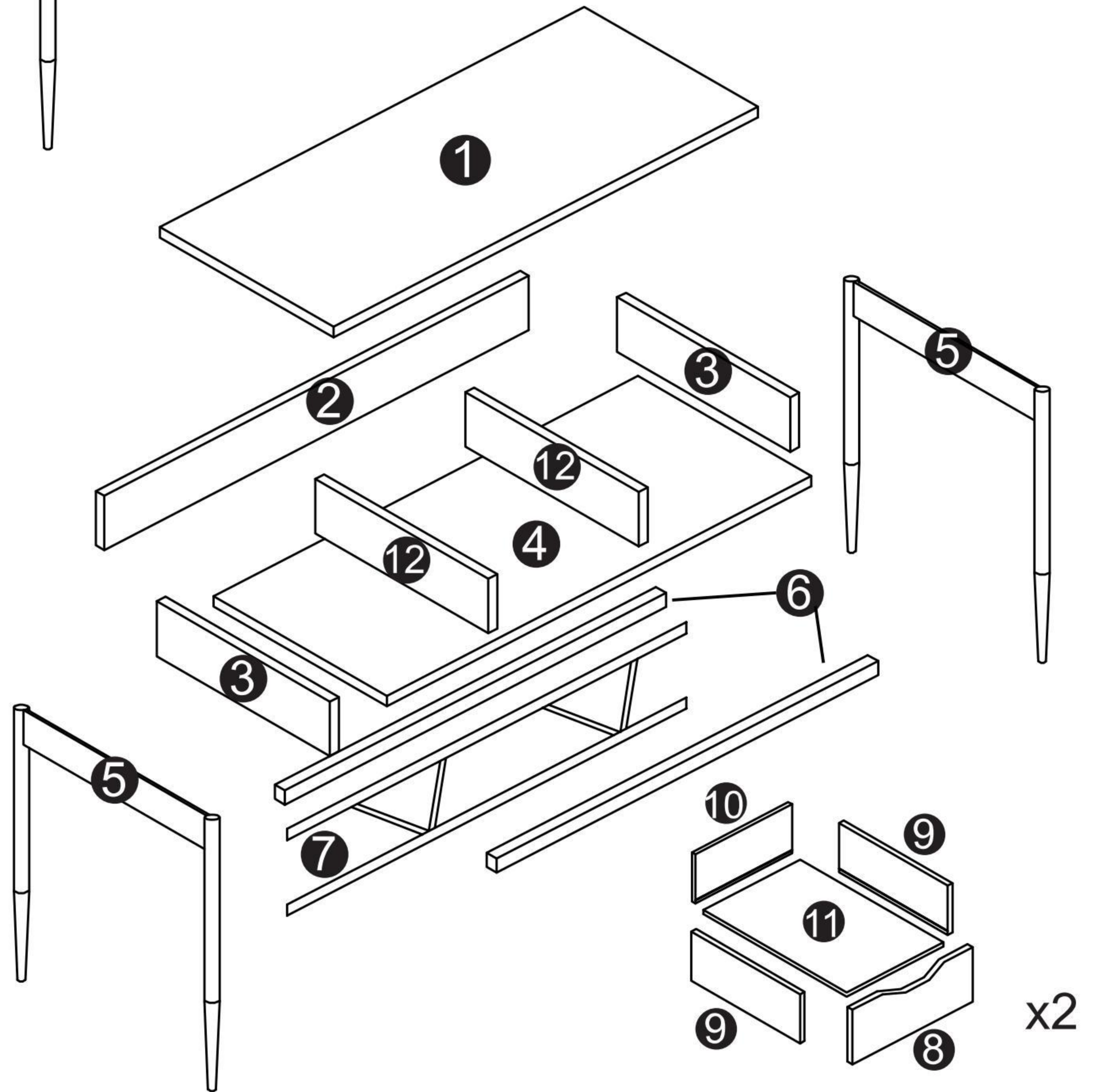
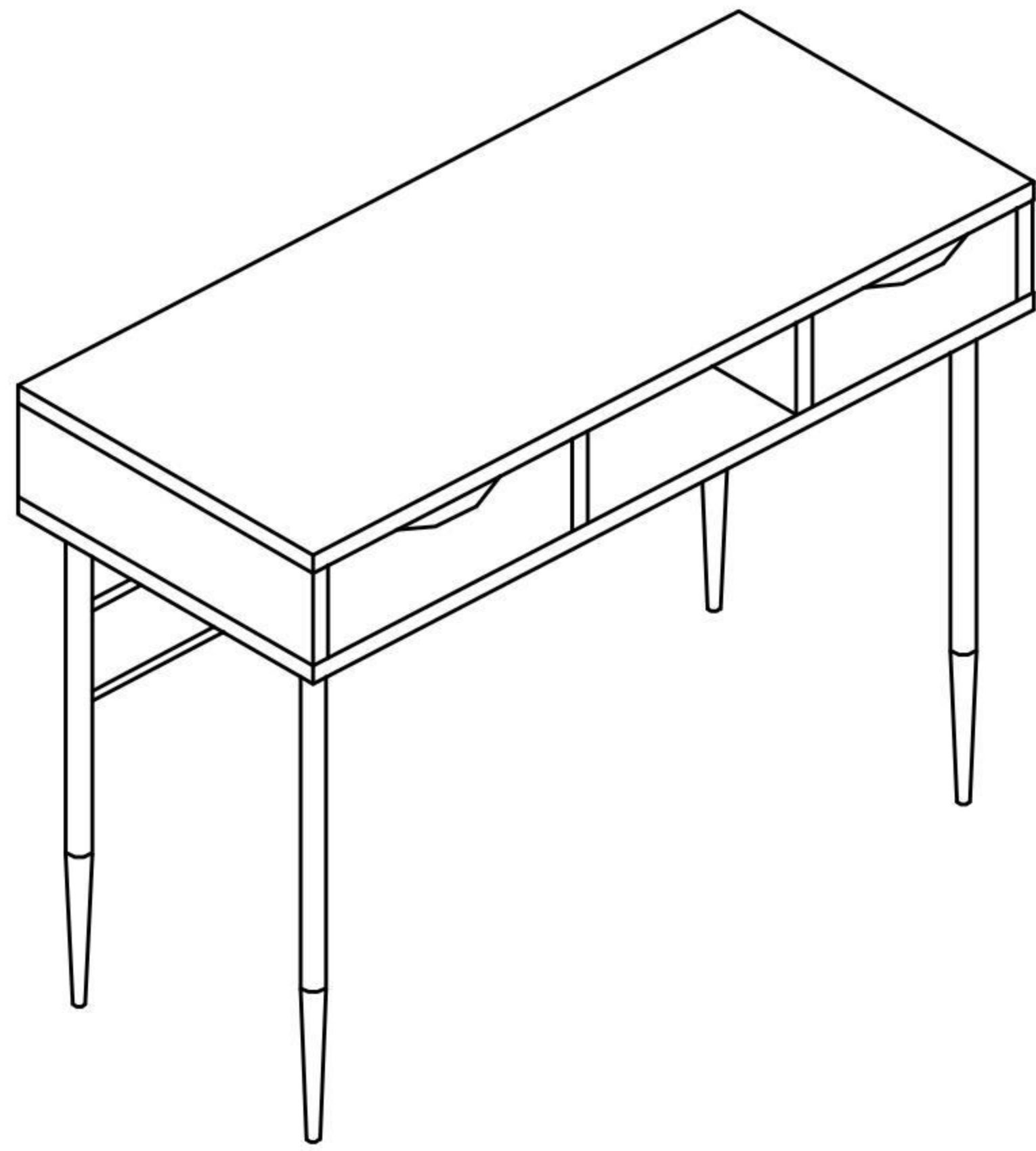

- (1) Top Panel x1
- (2) Back Panel x1
- (3) Outer Side Panel x2
- (4) Base Panel x1
- (5) Leg Frame x2
- (6) Metal Brace x2
- (7) Rear Frame x1
- (8) Drawer Front x2
- (9) Drawer Side x4
- (10) Drawer Back x2
- (11) Drawer Base x2
- (12) Inner Panel x2

HARDWARE LIST

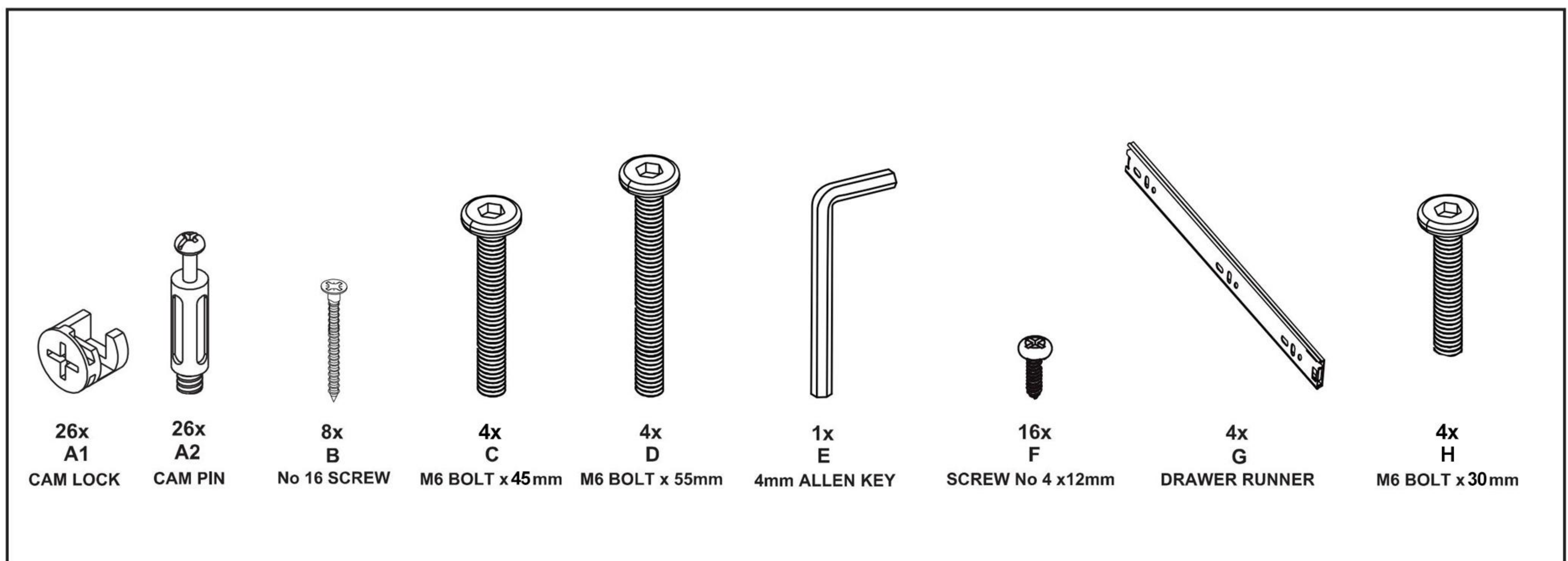

STEP 1

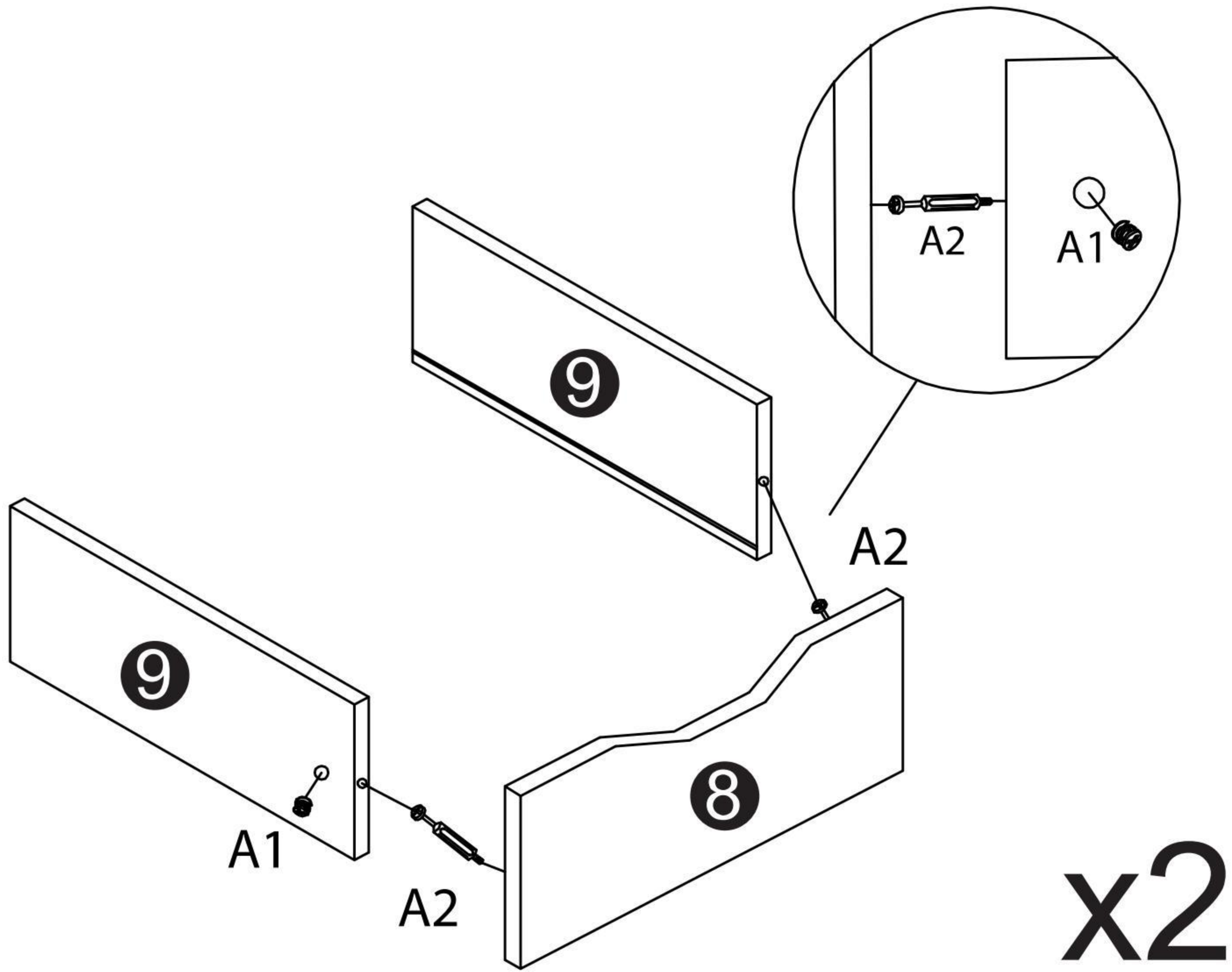

STEP 2

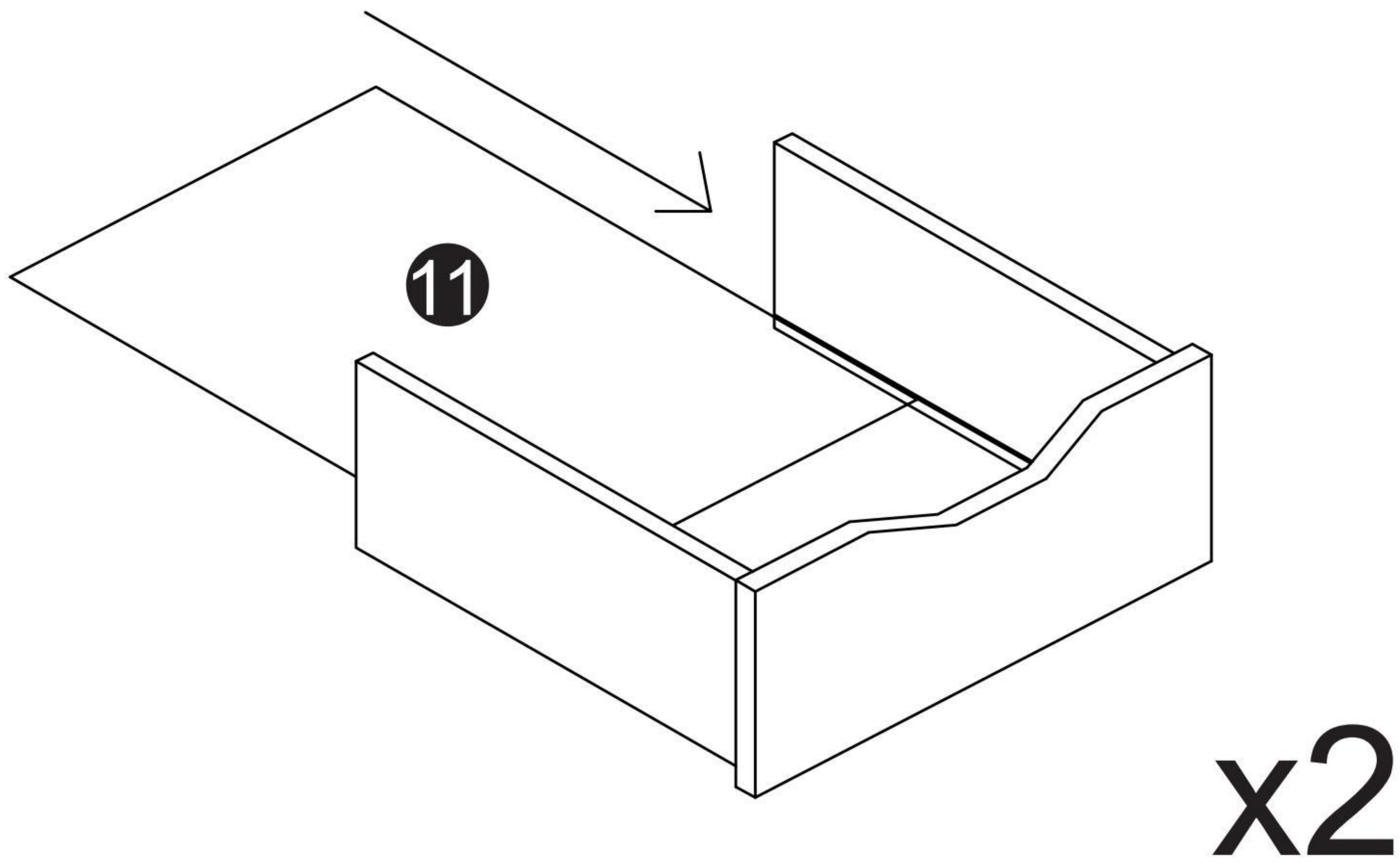

STEP 3

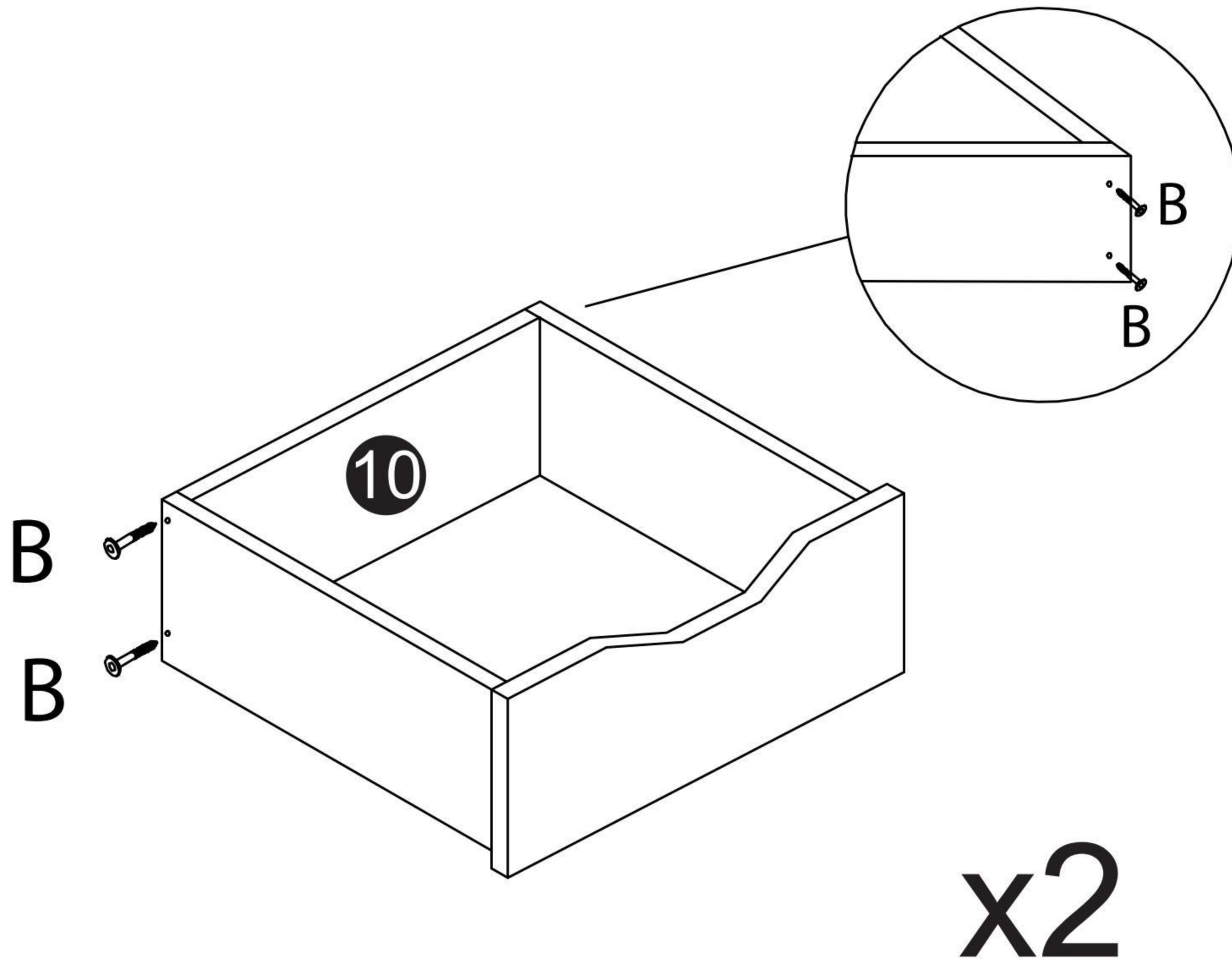

STEP 4

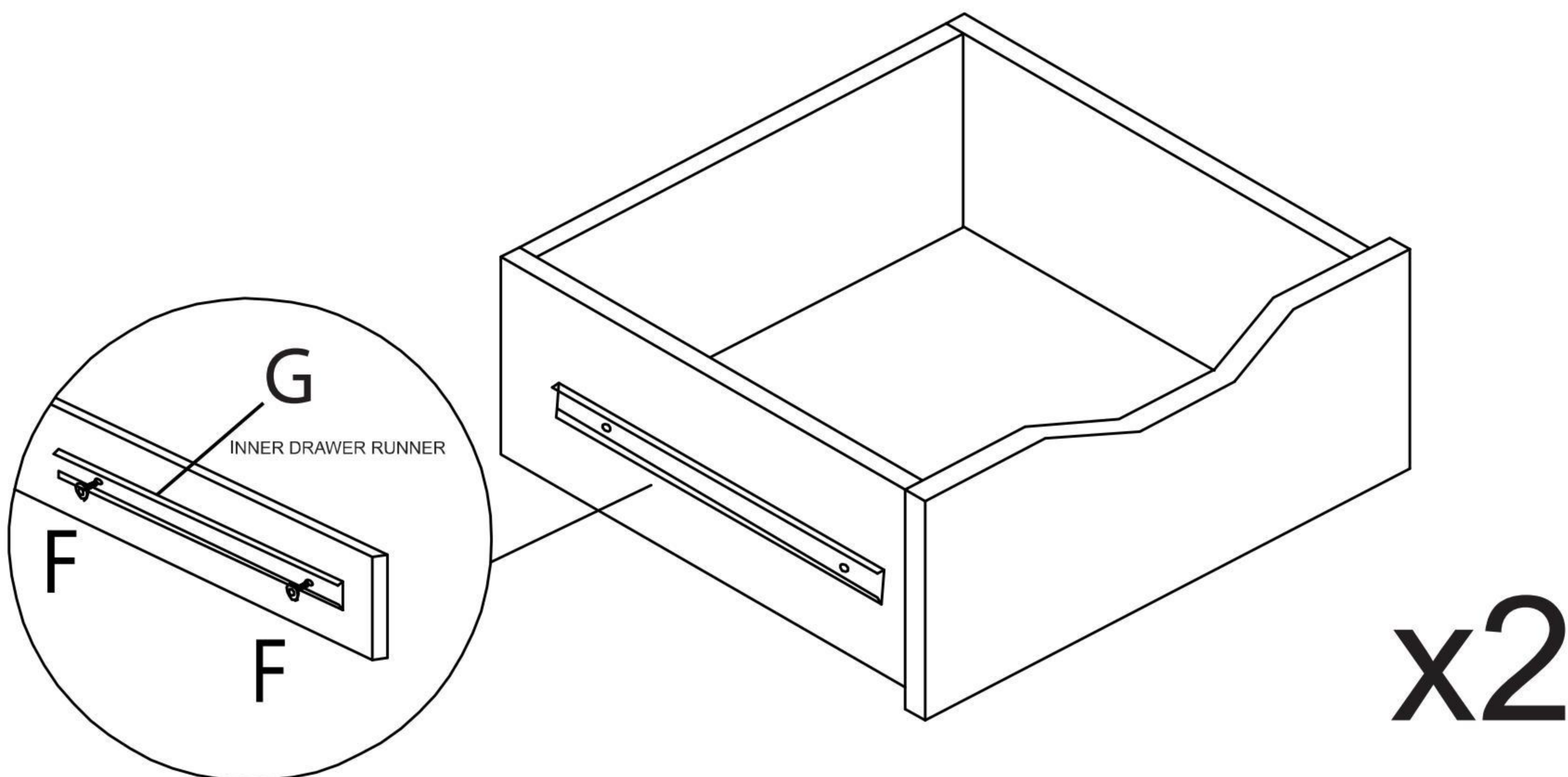
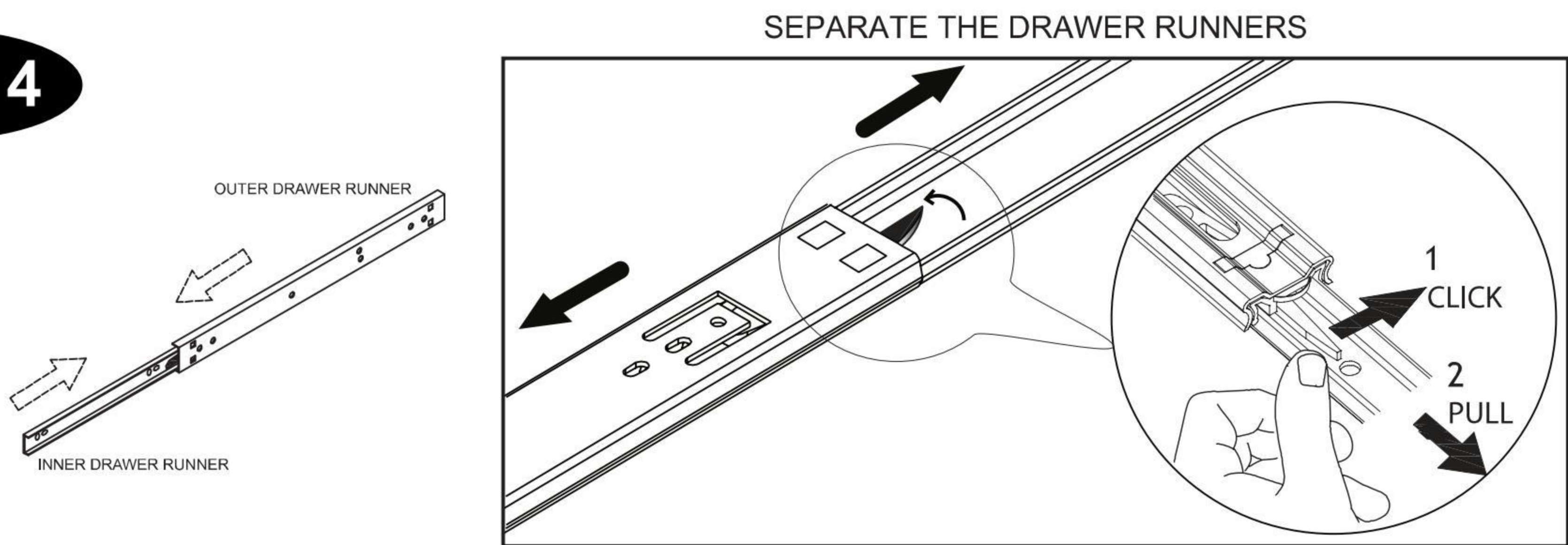

STEP 5

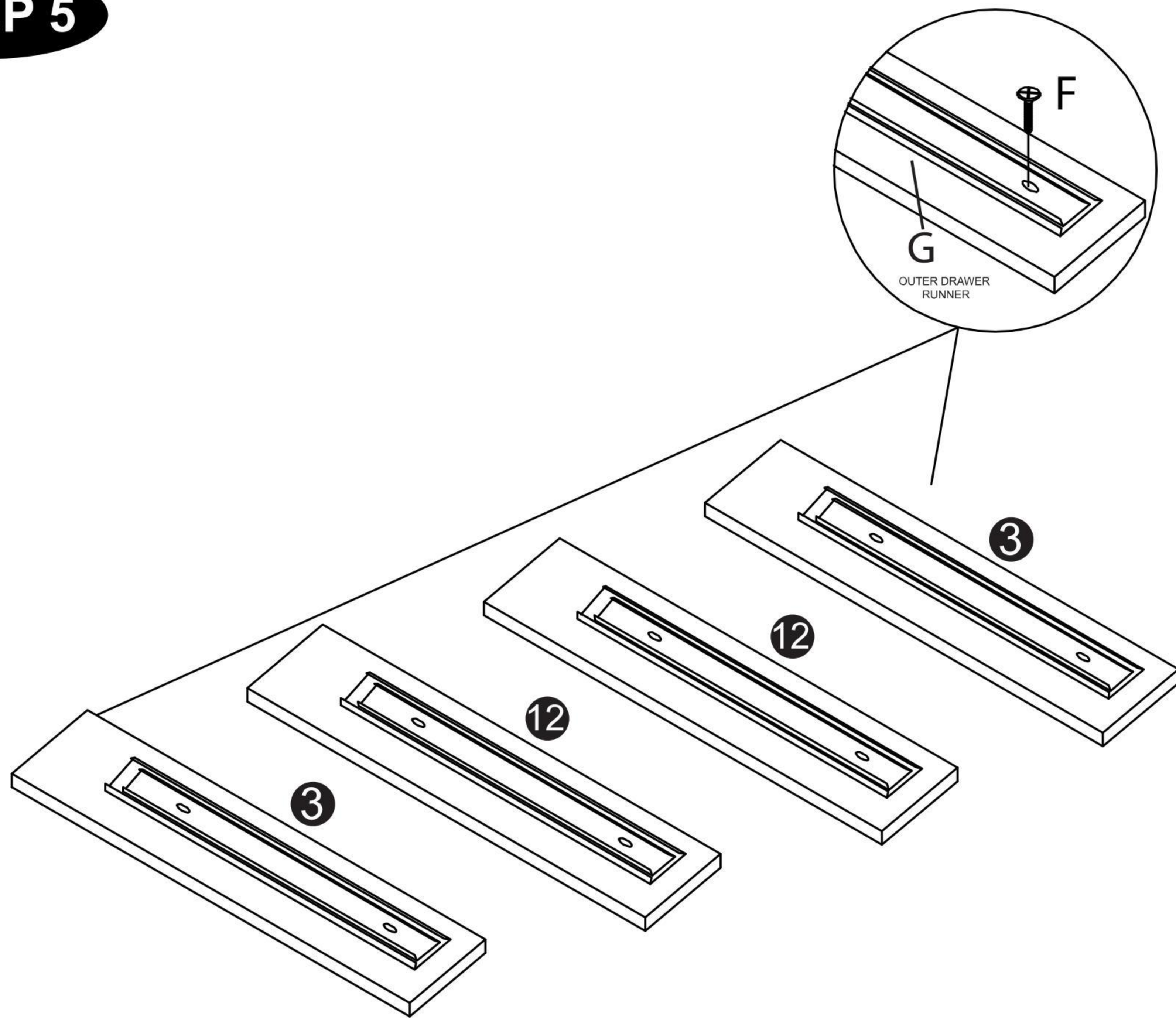

STEP 6

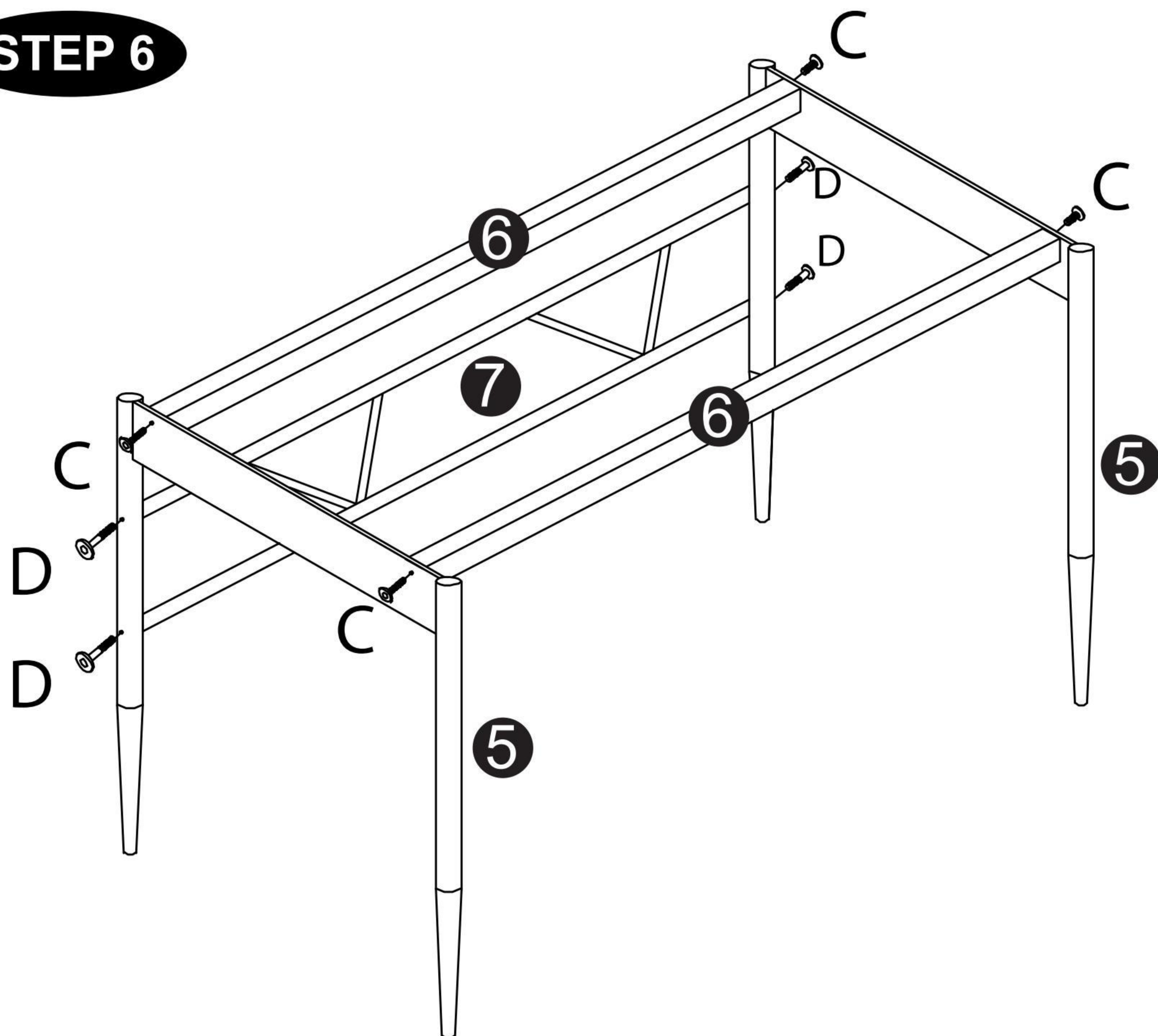

STEP 7

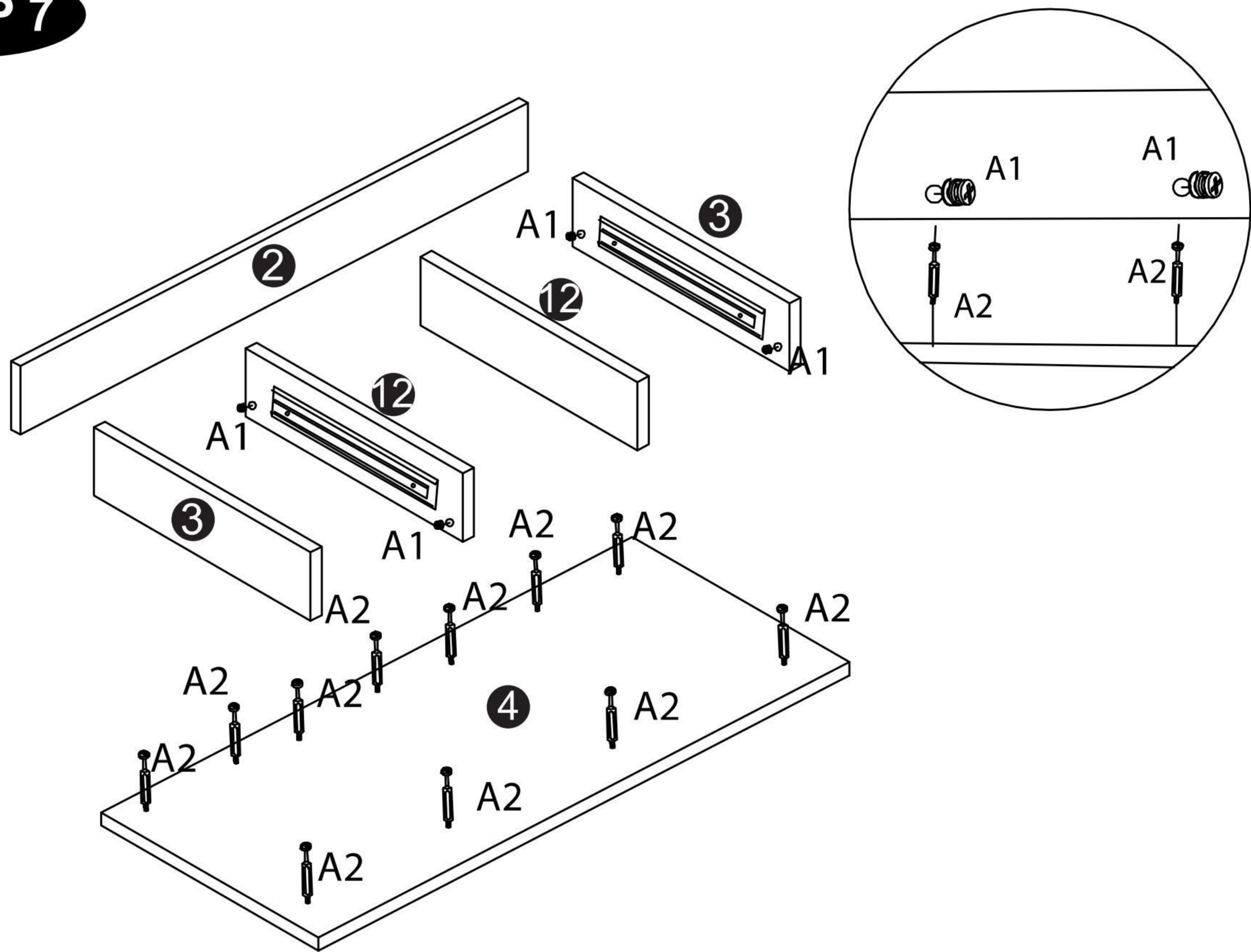

STEP 8

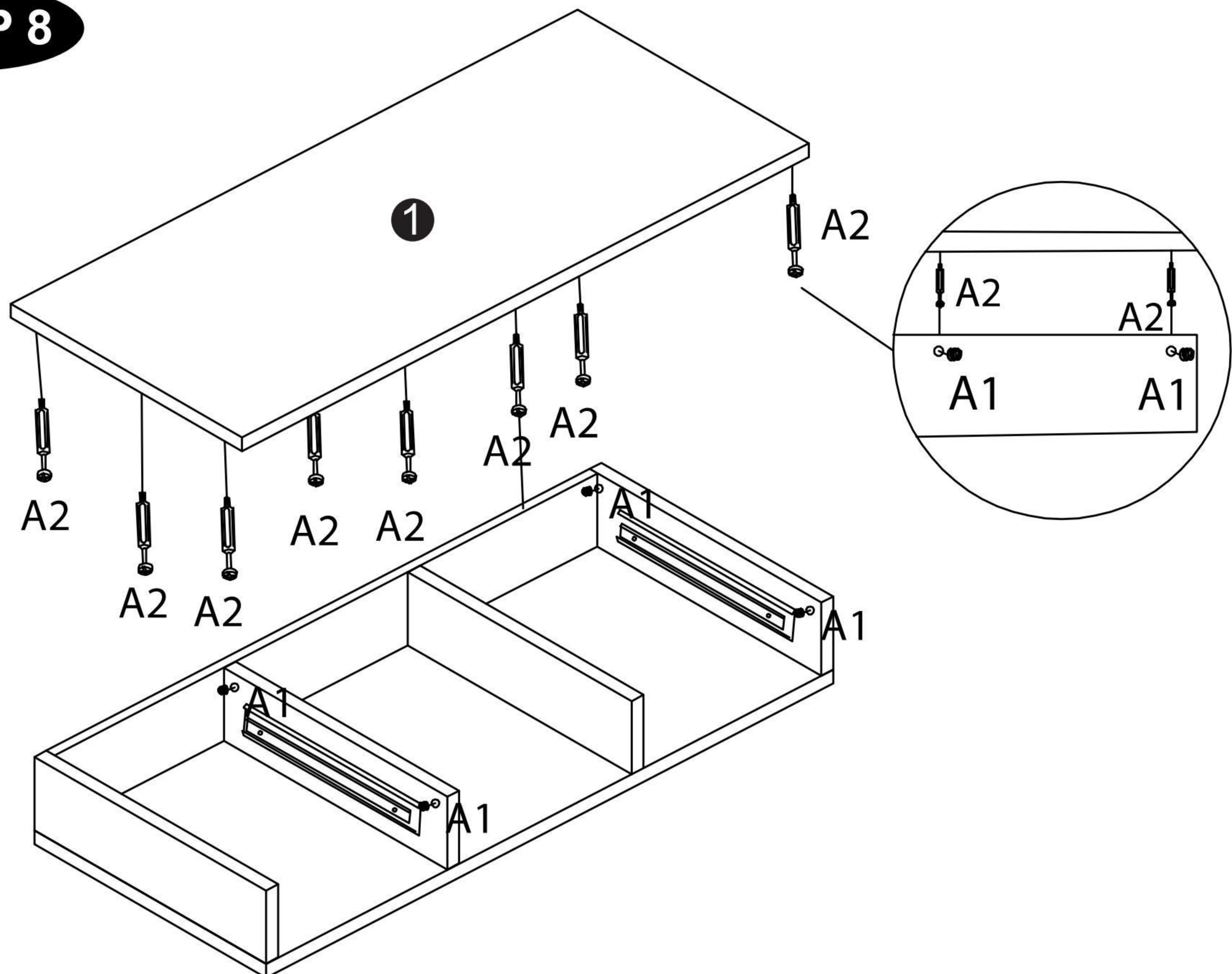

STEP 9

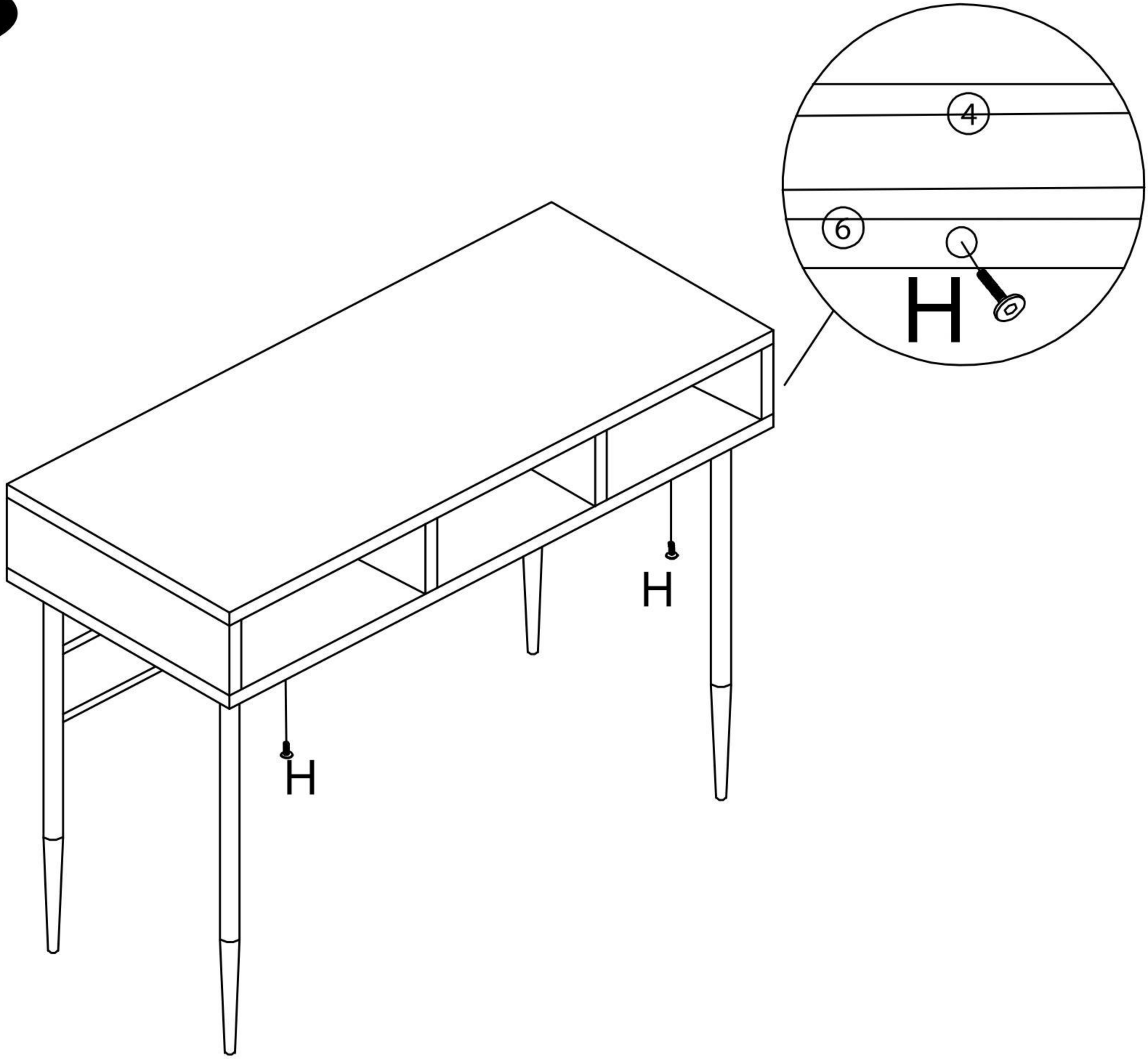

STEP 10

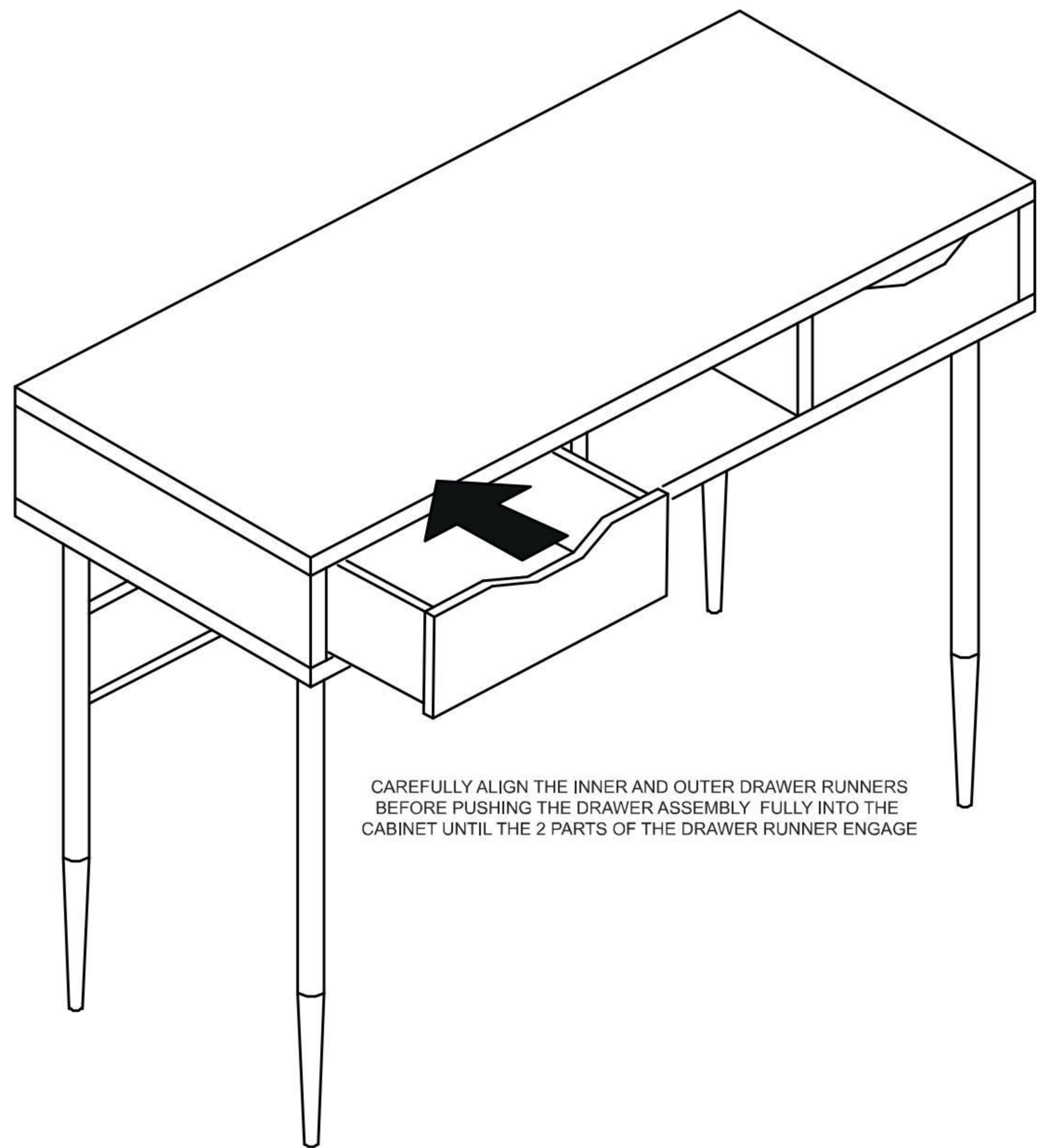

CAREFULLY ALIGN THE INNER AND OUTER DRAWER RUNNERS BEFORE PUSHING THE DRAWER ASSEMBLY FULLY INTO THE CABINET UNTIL THE 2 PARTS OF THE DRAWER RUNNER ENGAGE