

# ASSEMBLY INSTRUCTIONS



## TOOLS REQUIRED



Allen Wrench

(Included)



Phillips  
Screwdriver

(Not Included)



**2 - People  
Recommended**

## ASSEMBLY RATING



EASY —————> DIFFICULT

The Assembly Rating is a 5-point system showing the level of effort needed to assemble a specific product.



## **CHECK BEFORE STARTING**

- |   |  |
|---|--|
| <input type="checkbox"/> <b>Are you missing anything?</b><br>Double-check all parts, hardware and accessories listed are all accounted for.       | <input type="checkbox"/> <b>Check out our Quick Tips!</b><br>We recommend reviewing the pre-assembly handouts. Even experts need a refresher now and then! |
| <input type="checkbox"/> <b>Should we send any replacements?</b><br>Are there any irregularities or flaws in the parts? We can send replacements! | <input type="checkbox"/> <b>Prep Time!</b><br>Please review the assembly instructions and all diagrams prior to assembling.                                |

# PRE ASSEMBLY INTRODUCTION

We understand building ready-to-assemble furniture can be a challenging experience for some. To help avoid confusion, we have provided some helpful tips that may speed up the process.

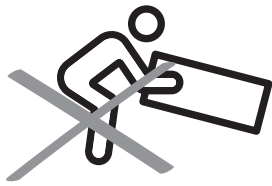

## Teamwork

ALWAYS have at least two people to help with transporting and assembling the product to avoid potential injury and/or damage.

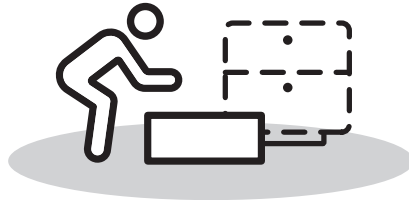
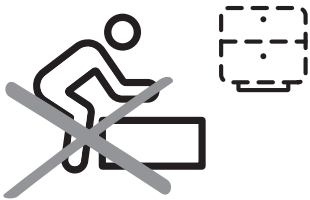

## Suitable Location

Assembling near the area of the intended location is highly recommended.



## Sufficient Space

Make sure you have enough space to move around during the assembly.



## Avoid Scratches

Use cardboard, blankets or a carpeted area while assembling furniture to prevent to prevent scratches and damages.

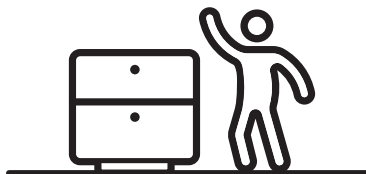
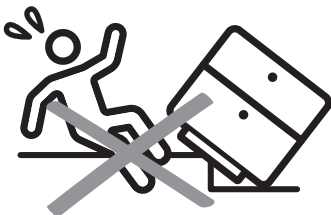

## Flat Surface

Make sure the furniture rests on a flat and level surface with each leg evenly touching the floor.

# ASSEMBLY AND CARE ADVICE



**FAILURE TO FOLLOW THE GUIDELINES BELOW MAY RESULT IN INJURY AND/OR PROPERTY DAMAGE.**



Position each part correctly and insert screws or bolts into their respective holes.



Turn clockwise to tighten and only tighten when step is completed or when instructed to do so.



Use the appropriate hand tools or power tools for assembly. Select steps, such as tightening screws and/or bolts, may require hand tools to avoid causing damage during assembly.



Save the instructions and store any supplied tools for later maintenance.



After two weeks, check and tighten any loose hardware and repeat again every six months thereafter.

**IT IS THE USER'S RESPONSIBILITY TO MAINTAIN THE FURNITURE. THE HARDWARE MAY LOOSEN OVER TIME AND MAY CAUSE THE FURNITURE TO BE WOBBLY AND UNABLE TO SUPPORT ITS INTENDED WEIGHT CAPACITY. THIS MAY LEAD TO COLLAPSE AND MAY CAUSE SERIOUS INJURY.**

# COMPUTER DESK



- Please keep instructions for future reference.
- Check the quantity and irregularity of parts and hardware before you start.

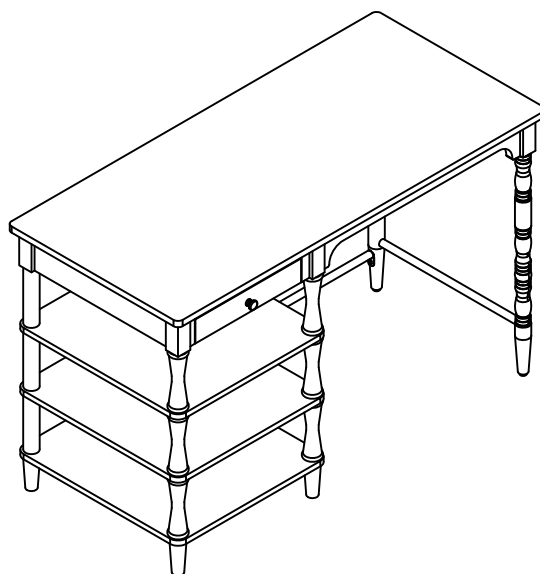

## PARTS

#1 1pc

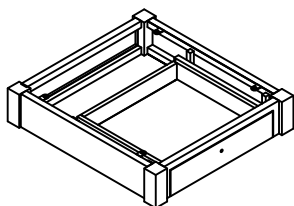

Drawer Frame

#2 1pc

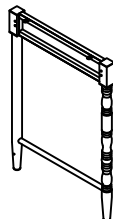

Left Frame

#3 1pc

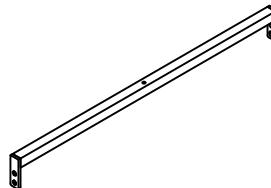

Upper Back Brace

#4 1pc

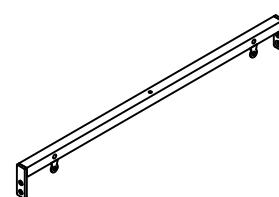

Upper Front Brace

#5 1pc

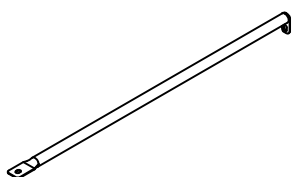

Bottom Cross Bar

#6 6pcs



Front Connected Post

#7 6pcs

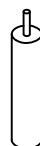

Back Connected Post

#8 4PCS



Support Leg Post

#9 1pc

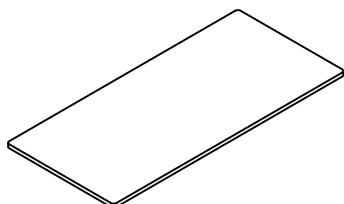

Desk Top

#10 3pcs

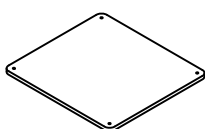

Shlef Board

#11 1pc

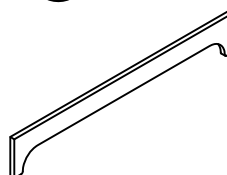

Front Board

#12 1pc

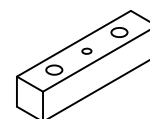

Block

## HARDWARE

#A 7pcs



Bolt  $\phi 1/4$ "x $1/2$ "  
(White)

#B 2pcs



Bolt  $\phi 1/4$ "x $1-1/4$ "  
(White)

#C 3pcs



Bolt  $\phi 3/16$ "x $3/8$ "  
(White)

#D 4pcs



Bolt  $\phi 3/16$ "x $1-1/8$ "  
(White)

#E 8pcs



Bolt  $\phi 1/4$ "x $5/8$ "  
(White)

#F 9pcs



Flat Washer  $\phi 1/4$ "  
(White)

#G 1pc

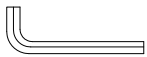

Allen Wrench  
4x22x60mm  
(White)

#H 1pc



Cover 55x24mm  
White

# ASSEMBLY INSTRUCTIONS

# 1

## ASSEMBLY

Do not fully tighten all bolts until assembly is complete. This will help all parts to assemble properly.

Part #9 x1pc

Part #12 x1pc

Hardware #D x2pcs

Hardware #C x1pc

Hardware #H x1pc

Align block (#12) to the hole of the desk top (#9), secure by using bolt (#D), then align cover (#H) to the middle hole of the block, secure by using bolt (#C).

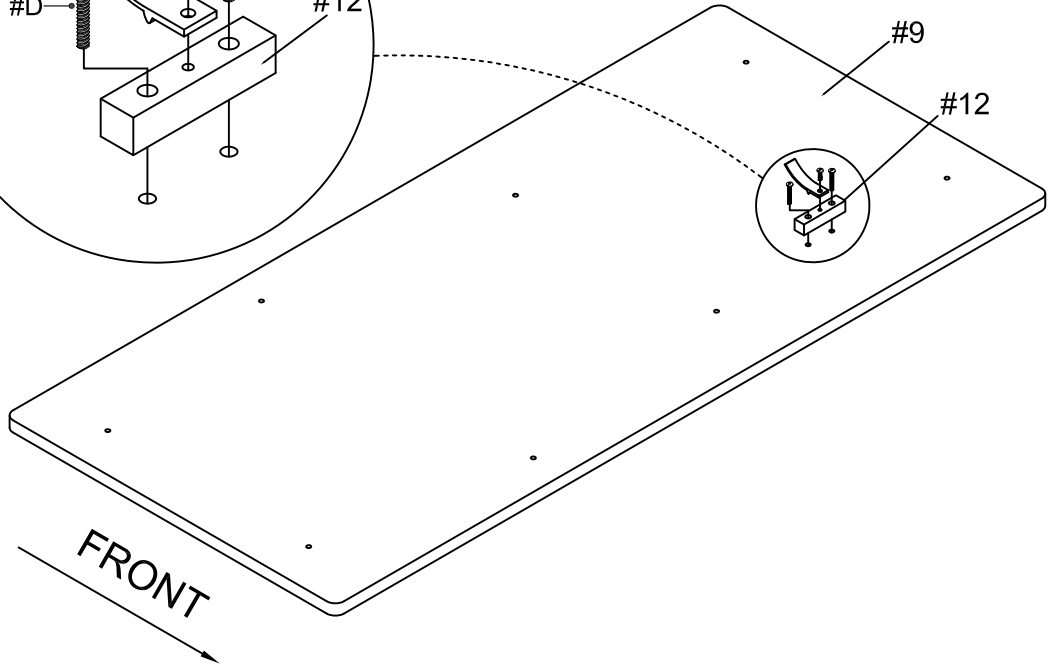
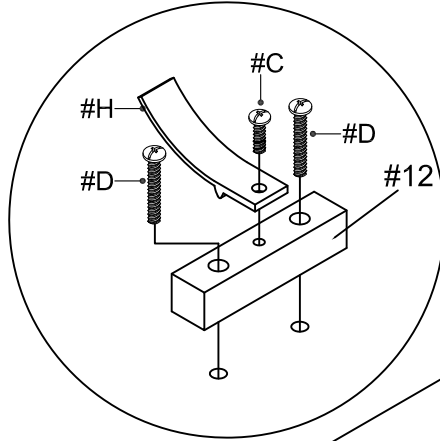

# 2

Part #1 x1pc

Please pull the drawer out of the frame (#1) completely as shown in the diagram.

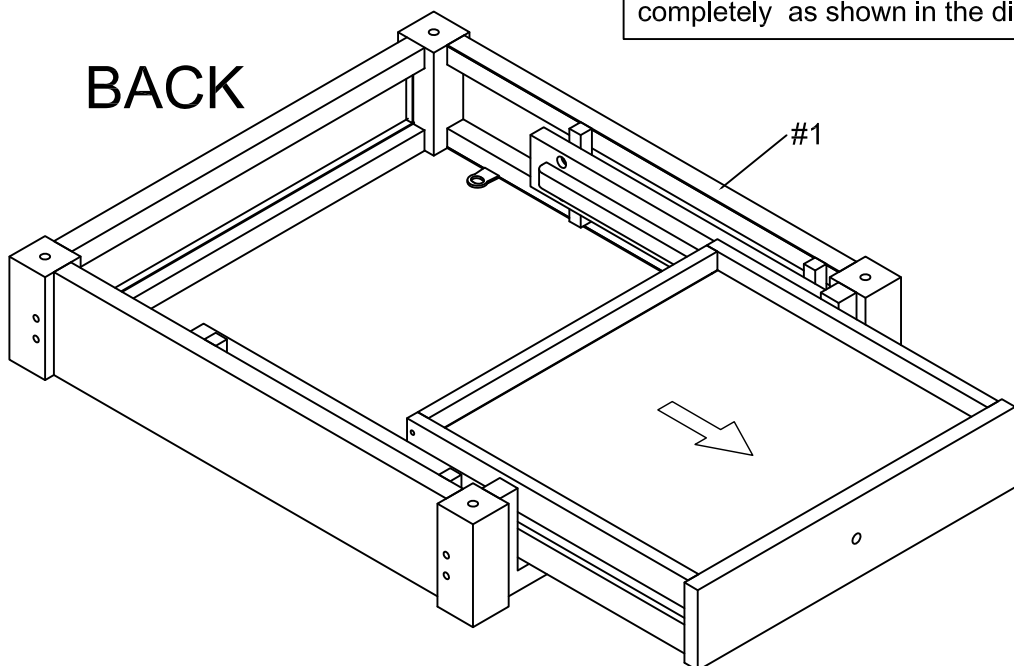

# ASSEMBLY INSTRUCTIONS

## 3

Hardware **#A** x4pcs

Hardware **#F** x4pcs

Hardware **#G** x1pc

Align drawer frame (#1) to the right holes of the desk top (#9), then secure by using bolt (#A) with washer (#F).

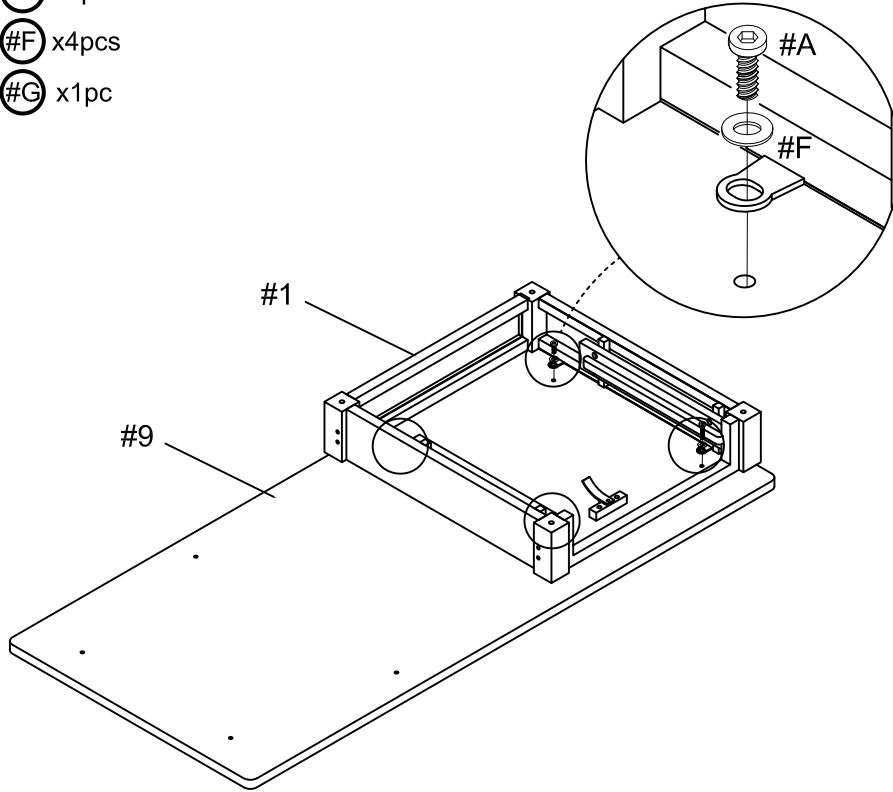

## 4

Part **#2** x1pc

Hardware **#A** x2pcs

Hardware **#F** x2pcs

Hardware **#G** x1pc

Align Left frame (#2) to the left holes of the desk top (#9), then secure by using bolt (#A) with washer (#F).

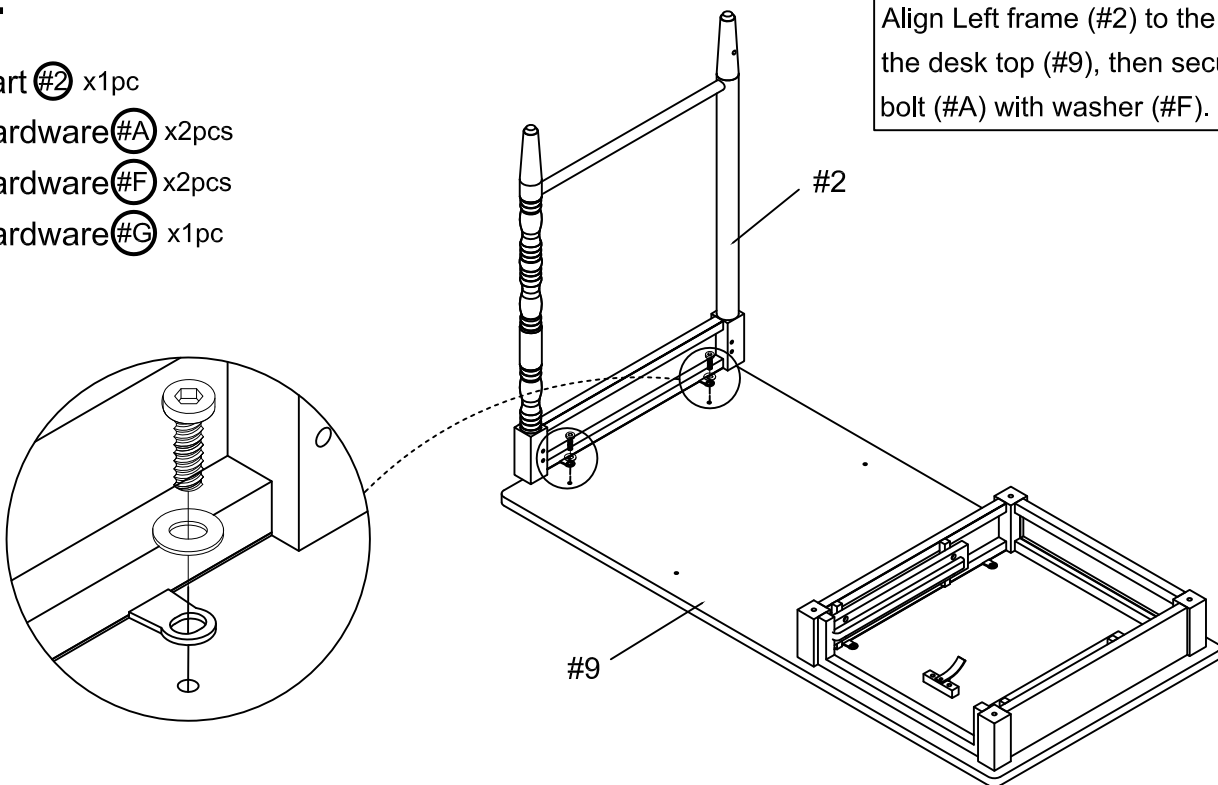

# ASSEMBLY INSTRUCTIONS

## 5

Part #3 x1pc

Part #4 x1pc

Hardware #B x2pcs

Hardware #E x8pcs

Hardware #F x2pcs

Hardware #G x1pc

Align upper braces (#3, #4) to left frame (#2) and drawer frame (#1), then secure by using bolts (#B, #E) with washer (#F).

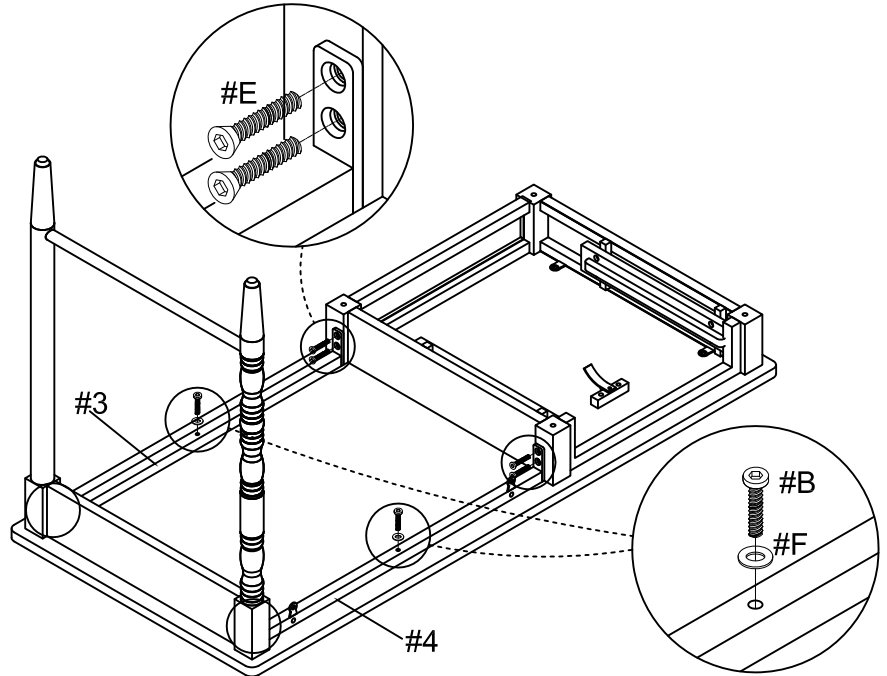

## 6

Part #11 x1pc

Hardware #C x2pcs

Hardware #D x2pcs

Align front board (#11) to upper front brace (#4), then secure by using bolts (#C, #D).

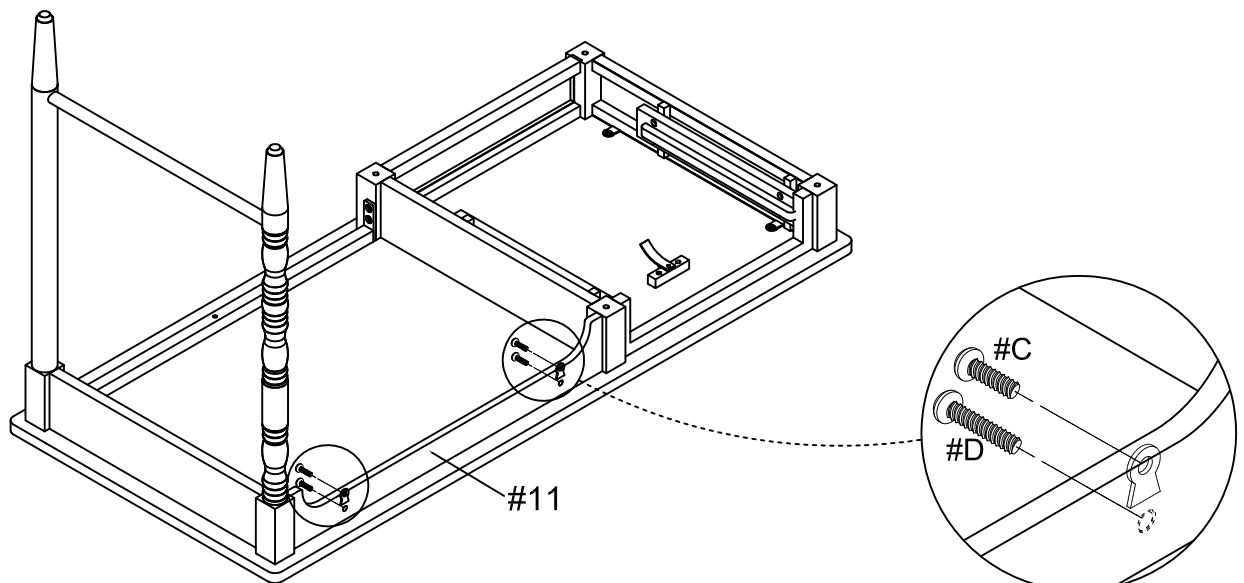

# ASSEMBLY INSTRUCTIONS

## 7

Part #6 x2pcs

Part #7 x2pcs

Align front connected post (#6) to the front hole of the drawer frame (#1), align back connected post (#7) to the back hole of the drawer frame (#1) as shown in the diagram.

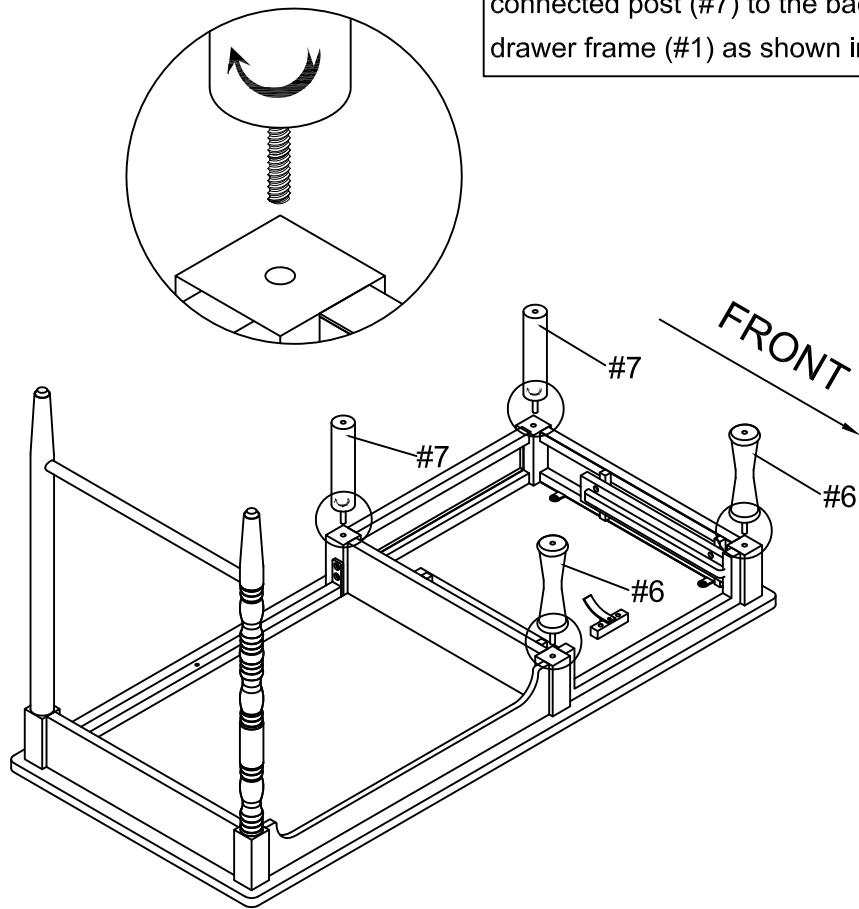

## 8

Part #6 x2pcs

Part #7 x2pcs

Part #10 x1pc

Put the shelf board (#10) on connected posts (#6, #7), then align connected post (#6, #7) to connected posts (#6, #7) through the hole of the shelf board (#10) as shown in the diagram.

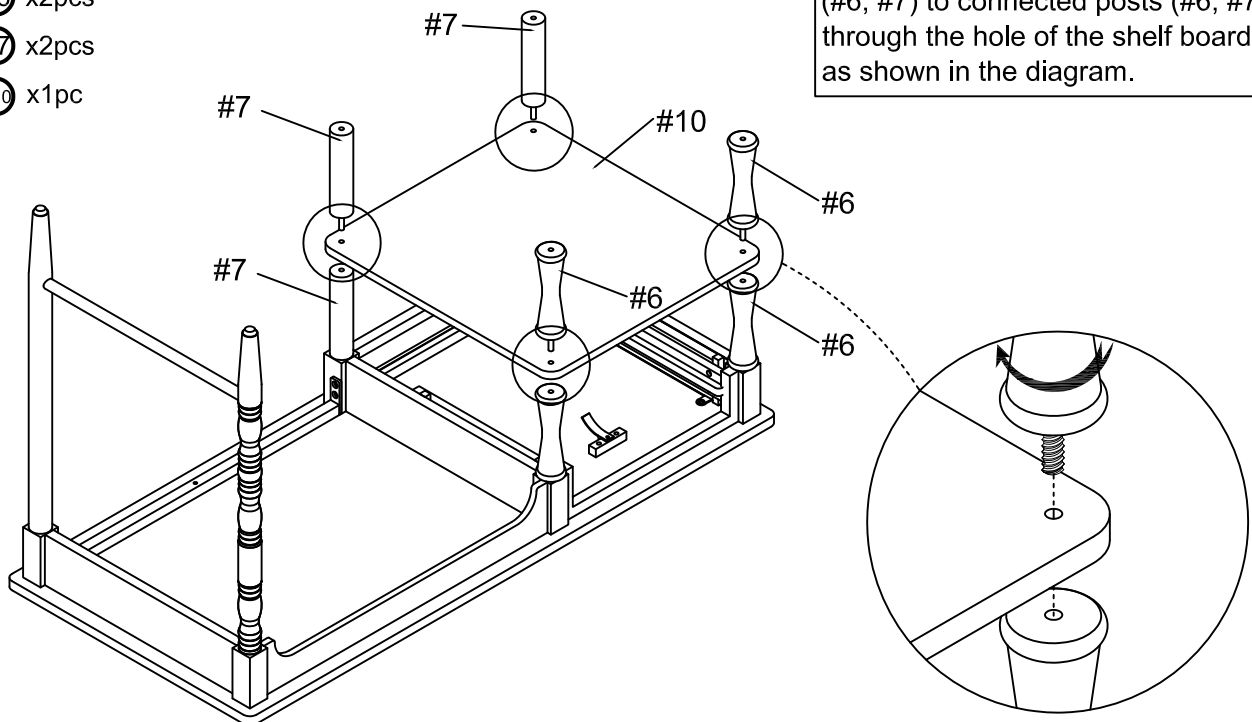

# ASSEMBLY INSTRUCTIONS

## 9

Part #6 x2pcs

Part #7 x2pcs

Part #10 x1pc

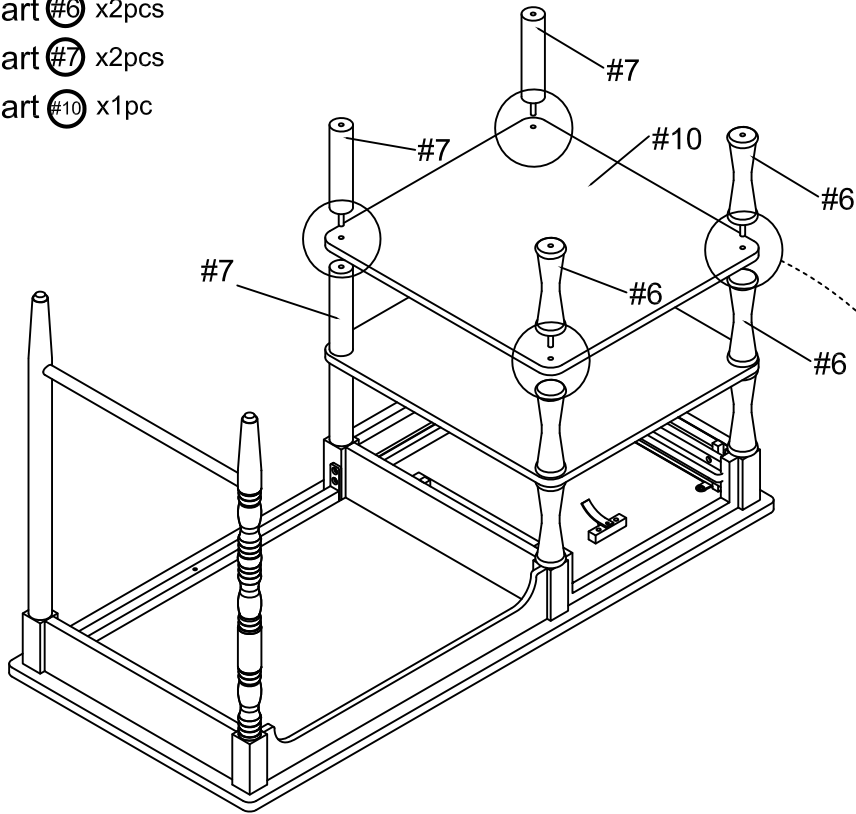

Put the shelf board (#10) on connected posts (#6, #7), then align connected post (#6, #7) to connected posts (#6, #7) through the hole of the shelf board (#10) as shown in the diagram.

## 10

Part #10 x1pc

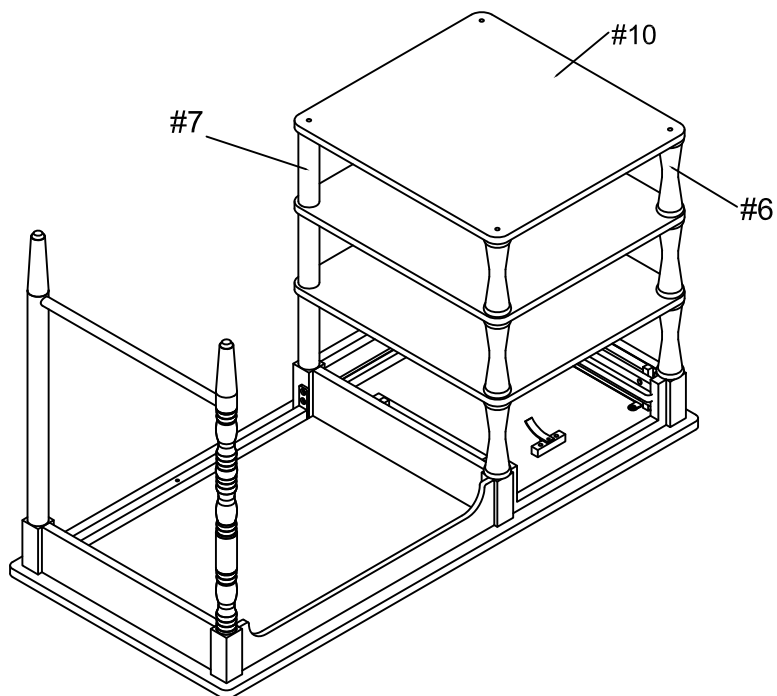

Put the shelf board (#10) on connected posts (#6, #7) as shown in the diagram.

# ASSEMBLY INSTRUCTIONS

## 11

Part #5 x1pc

Part #8 x4pcs

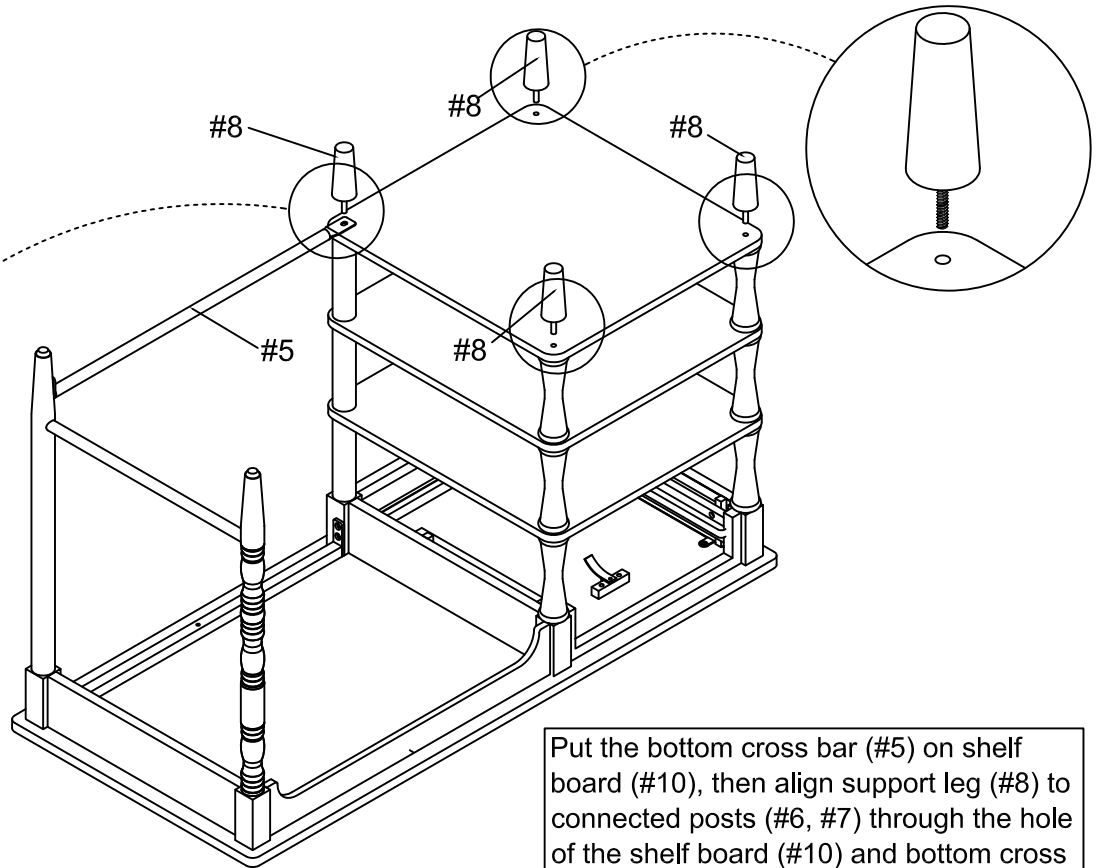
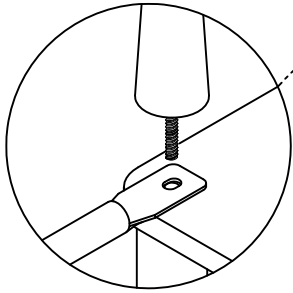

Put the bottom cross bar (#5) on shelf board (#10), then align support leg (#8) to connected posts (#6, #7) through the hole of the shelf board (#10) and bottom cross bar (#5) as shown in the diagram.

## 12

Hardware #A x1pc

Hardware #F x1pc

Hardware #G x1pc

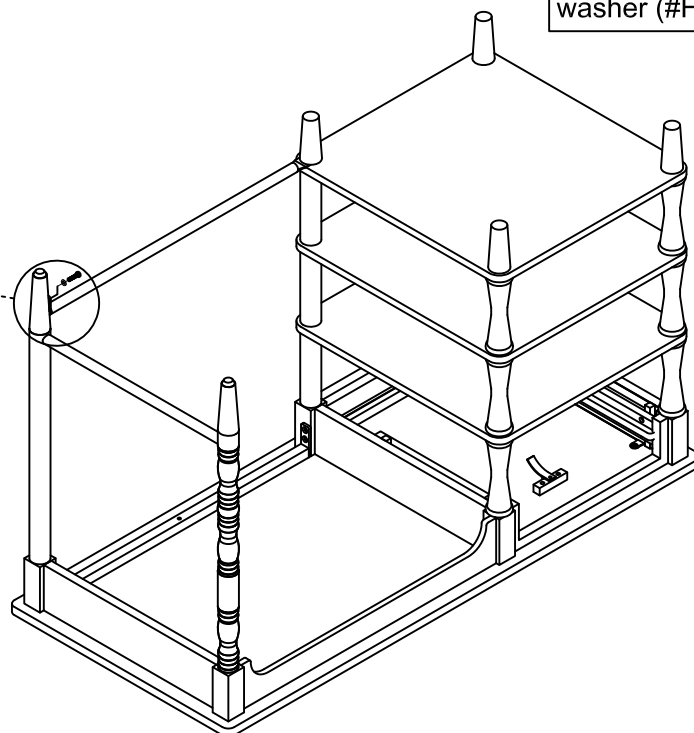
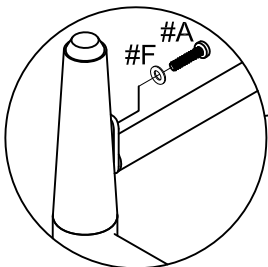

Align bottom cross bar (#5) to left frame (#2), then secure by using bolts (#A) with washer (#F).

# ASSEMBLY INSTRUCTIONS

13

Assemble the drawer to the frame (#1) as shown in the diagram.

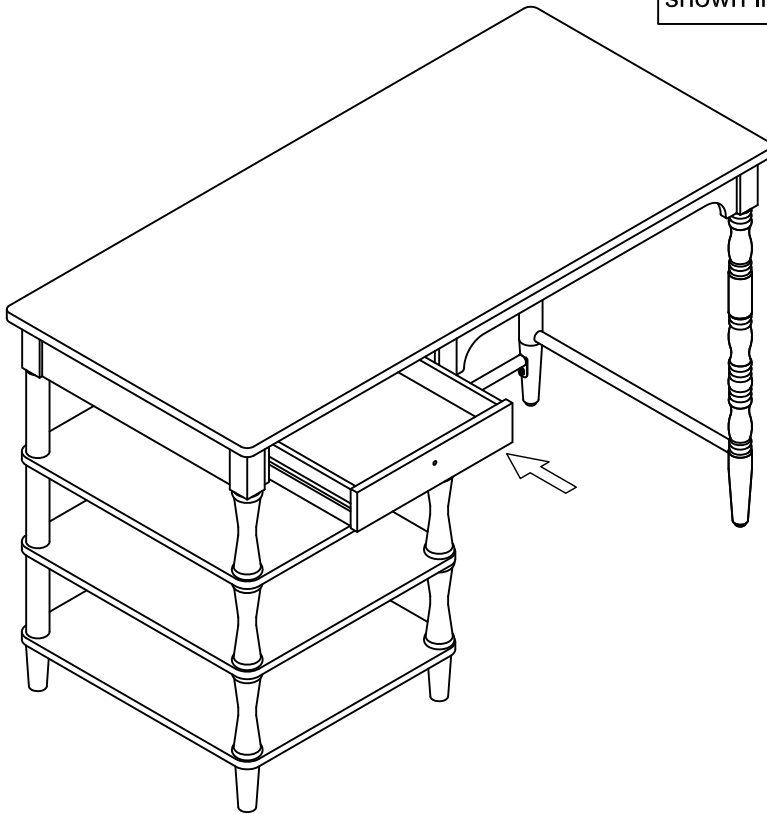

14

Take down the handle from the inside of the drawer front panel.

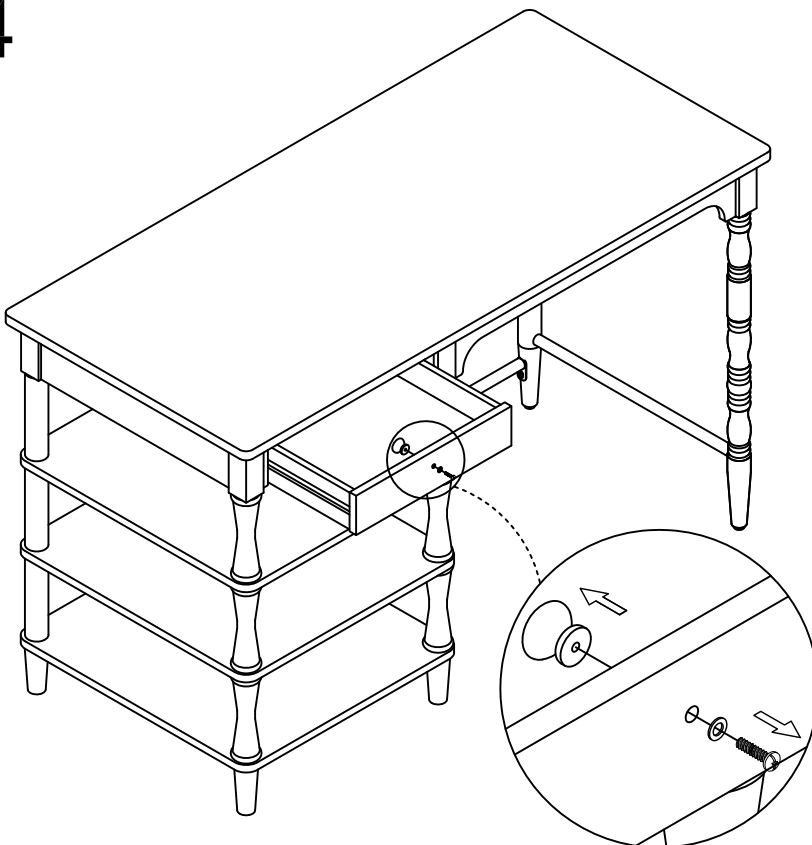

Note:  
These handle, bolt and washer will be used in next step, please don't throw them away.

# ASSEMBLY INSTRUCTIONS

15

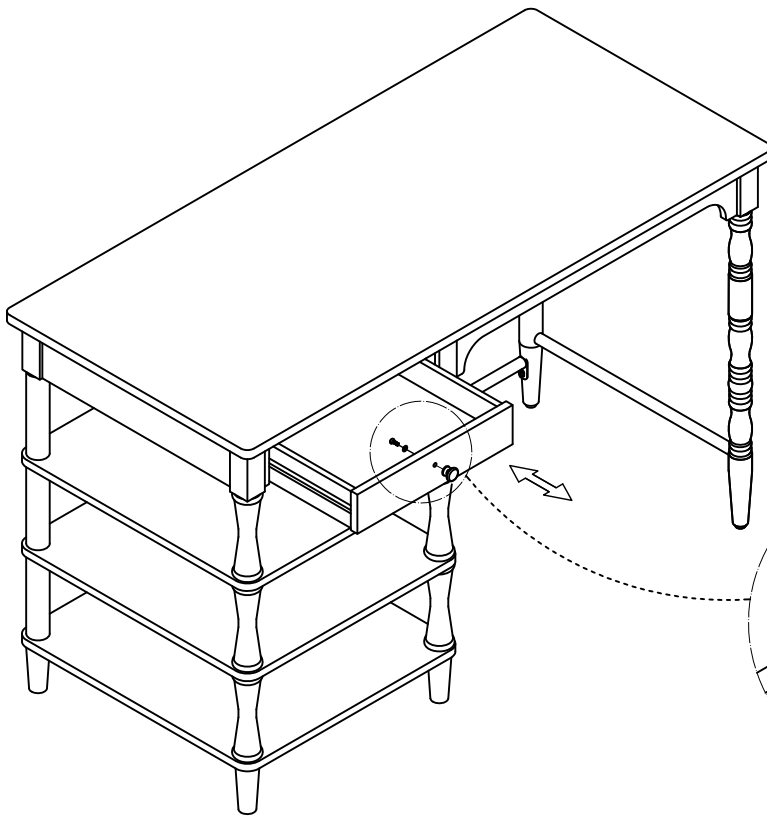

Align the handle to the drawer front panel by using bolt with washer as shown in the diagram.

16

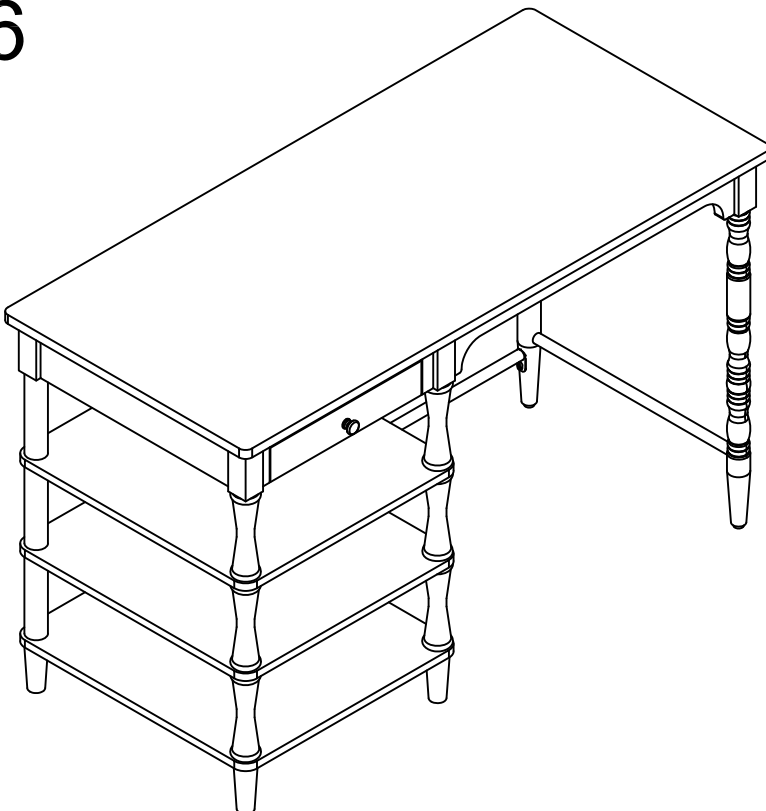

## ASSEMBLY COMPLETED



Please ensure the furniture rests on an even and flat surface. If the product wobbles or feels loose, double-check all bolts and/or screws are properly tightened and secured.



### Keep this handy!

Please retain this instruction manual and any order-related information for future reference.



### Lift, don't drag!

To avoid damage to product please always LIFT the product when transporting or adjusting the placement.