

# FURNITURE

## ASSEMBLY INSTRUCTION

### DESCRIPTION SPLAT BACK SIDE CHAIR

Thank you for purchasing this quality product. Be sure to check all packing material carefully for small parts which may have come loose inside the carton during shipment. Identify and count all parts and compare with the parts List Below :

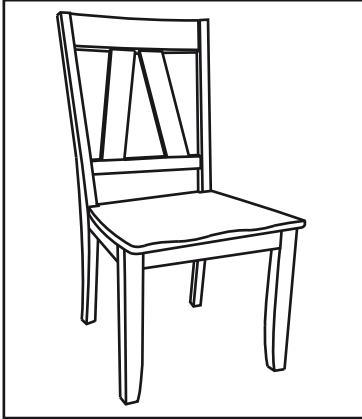

#### PART LIST

NO	SKETCH	DESCRIPTION	Q'TY
1		Chair Back	1 pc
2		Hardseat	1 pc
3		Seat Frame	1 pc
4		Front Leg	2 pcs

ASSEMBLY HARDWARE PACK (EACH CHAIR)			5
NO	SKETCH	HARDWARE	Q'TY
A		Wood Screw	6 pcs
B		JCBC Bolt (Short)	2 pcs
C		JCBC Bolt (Long)	8 pcs
D		Lock Washer	10 pcs
E		Flat Washer	10 pcs
F		Allen Key	1 pc

#### ASSEMBLY STEP

##### STEP 1

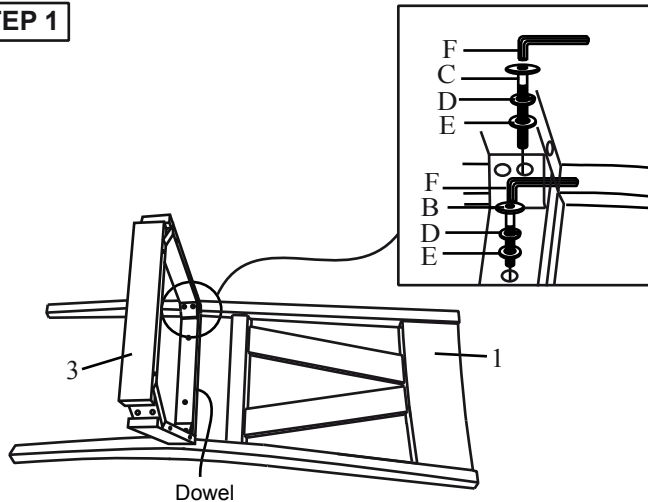

##### STEP 2

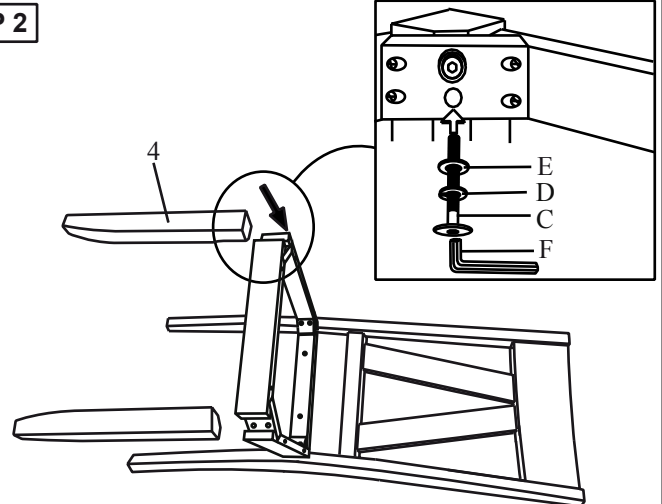

##### STEP 3

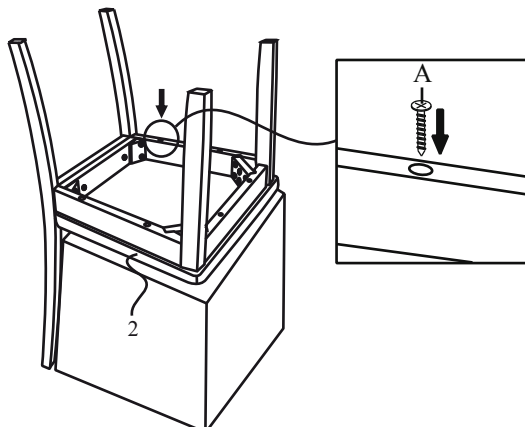

##### STEP 4

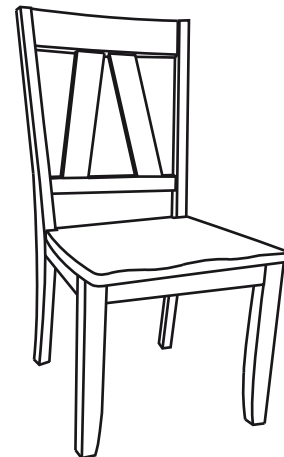

#### ASSEMBLY TIPS:

1. Remove hardware from box and sort by size.
2. Please check to see that all hardware and parts are present prior start of assembly.
3. Please follow attached instructions in the same sequence as numbered to assure fast and easy assembly.

#### WARNING!

1. Don't attempt to repair or modify parts that are broken or defective. Please contact the store immediately.
2. This product is for home use only and not intended for commercial establishments.