

ASSEMBLY INSTRUCTIONS

SKU:NVT



Factory2Home

FROM OUR FACTORY TO YOUR HOME

14800 Almeda School Road,

Houston, TX 77047

Email: sales@factory2home.net



Description : Norvia Oval Table

Product Dimension : 36"Wx60"Dx30"H

Cube Size : 64.3"x21.4"x6.7"

NW : 52.8 LBS

GW : 61.6 LBS

Norvia Oval Table

BEFORE ASSEMBLY

Thank you for purchasing this quality product. This product has been designed for easy assembly and constructed for durability. Please take the time to read and follow the assembly instructions carefully. Be sure to check all packing material carefully for small parts which may have come loose inside the carton during shipment. Please separate, identify, and count all parts and metal hardware. Compare with part list to be sure all parts are present. If hardware is missing or you have difficulty assembling this product, please contact us at sales@factory2home.net.



IMPORTANT NOTE:

- Place all wooden parts on a clean and smooth surface such as a rug or carpet to avoid the parts from being scratched.
- Remove all wrapping material, including staples & packing straps before you start to assemble.
- DO NOT TIGHTEN all screws and bolts until product is completely assembled.
- Keep all hardware parts out of reach of children.

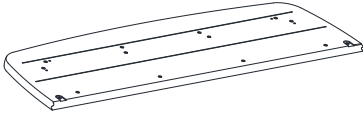
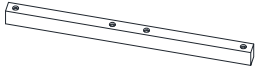
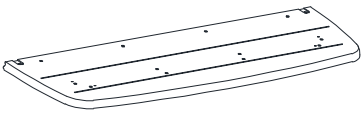
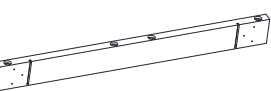
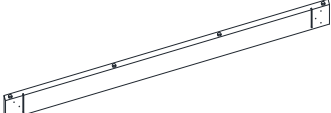
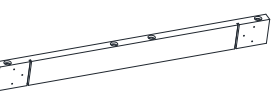

PART LIST

When unpacking, please be careful not to discard any parts with the packaging. Before continuing, please make sure you have the following parts:

NO	Description	Qty	Sketch	NO	Description	Qty	Sketch
A	Table Top	1		C	Cross bar	2	
B		1					
D	Long Apron	2		E	Short Apron	2	
F	Table Leg	4					

HARDWARE LIST

When unpacking, please be careful not to discard any parts with the packaging. Before continuing, please make sure you have all of the following hardware:

NO	Description	Qty	Sketch	NO	Description	Qty	Sketch
1	Bolt (M6x45mm)	8		2	Bolt (M6x12mm)	4	
3	Bolt (M6x60mm)	16		4	Screw (M4x15mm)	24	
5	Bolt (M8x45mm)	8		6	Lock Washer (ø8.5x13mm)	8	
7	Flat Washer (ø8.5x19mm)	8		8	Allen Key (4mm)	1	
9	Oval Mending Plate	2		10	Bracket	4	

STEP 1

- Attach Oval Mending Plate (9) to Tabletop (A), (B) using Bolts (2).
- Attach Cross Bar (C) to Table top (A), (B) using Bolts (1).
- Attach Short Apron (E) to Table top (A), (B) using Bolts (3). Tighten with Allen Key (8).

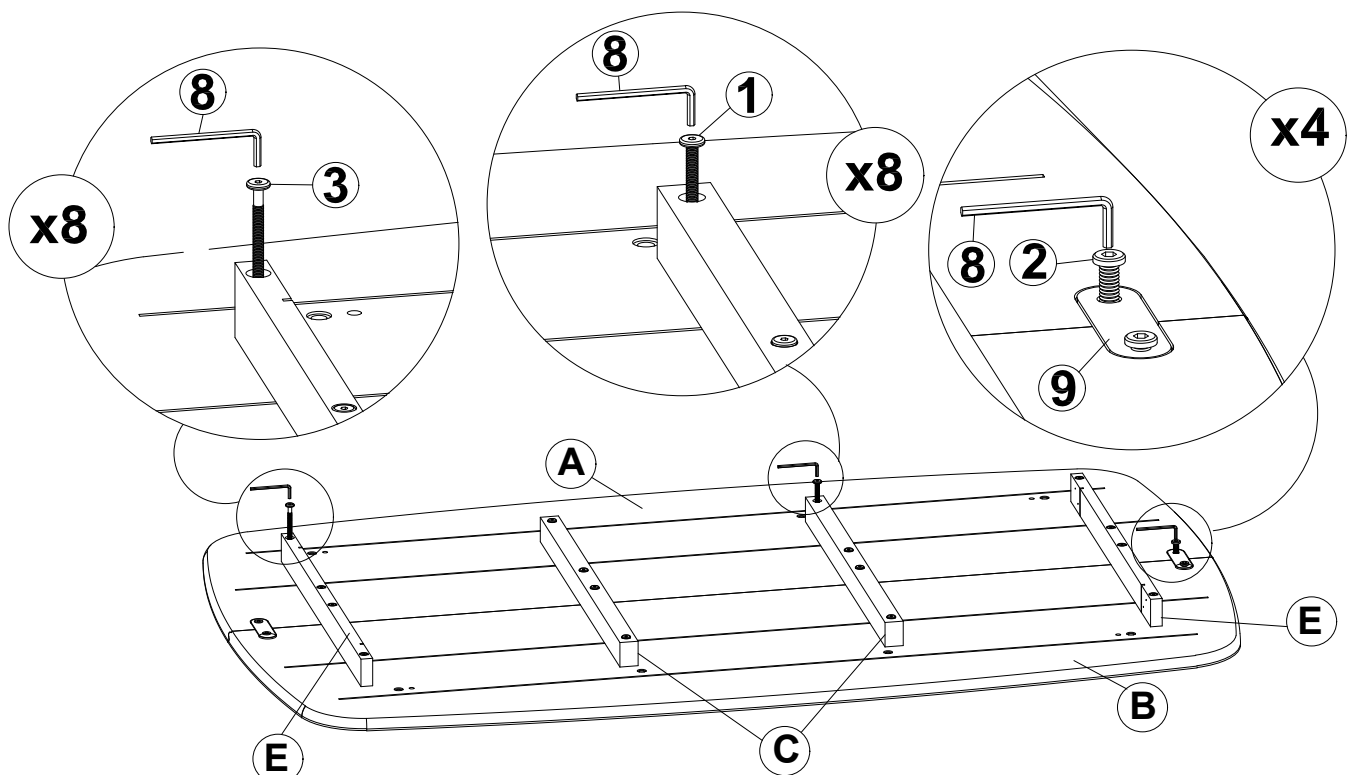

STEP 2

- Attach Long Apron (D) to the Table top (A), (B) using Bolts (3). Tighten with Allen Key (8).
- Attach the Bracket (10) centrally to the Long Apron (D) and Short Apron (E) using the Screws (4).

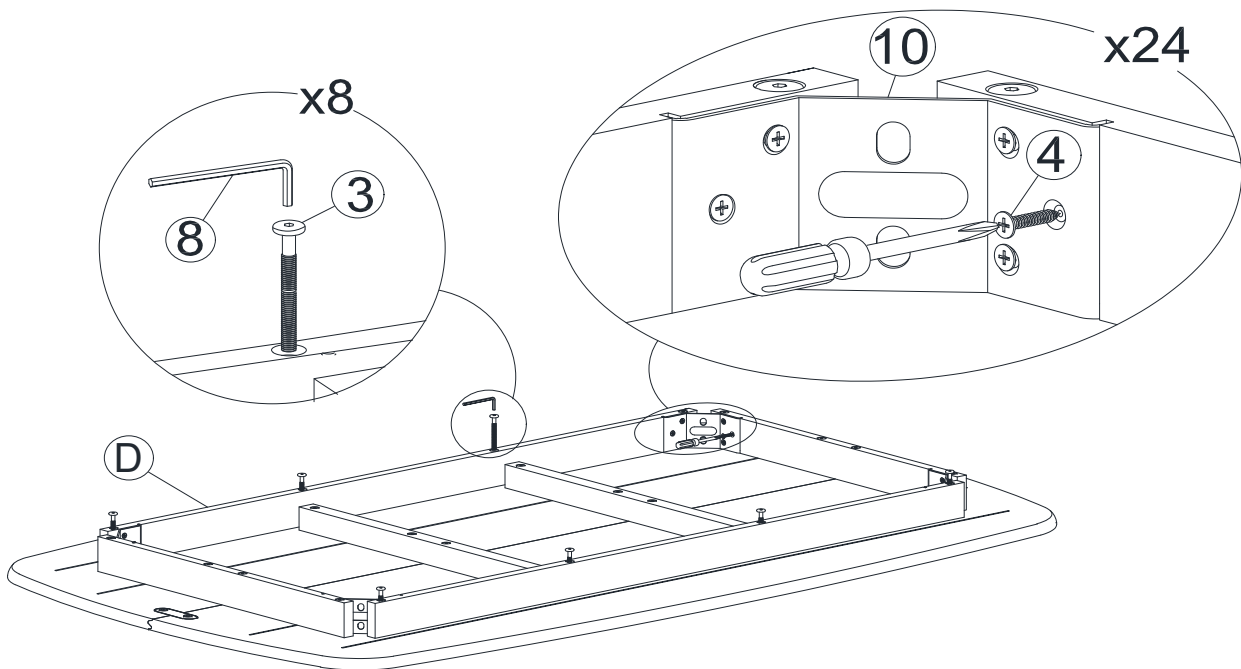

STEP 3

- Attach Table Legs (F) to the Bracket (From step 2) using Bolts (5), Lock Washer (6) and Flat Washer (7). Tighten with Allen Key (8).

