

# Metal Side Table

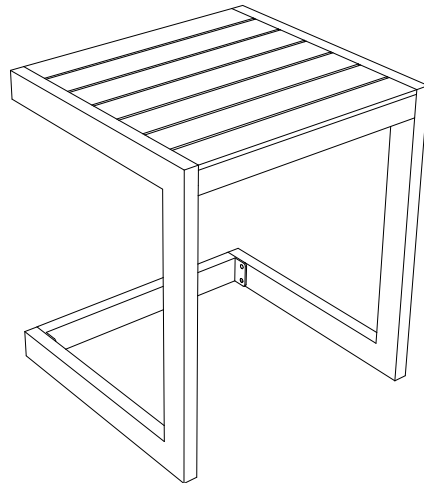

**Read the instructions before use of this product.**

Please keep this instruction manual for future reference.

## ! NOTICE

- Please keep children away during assembly. This item contains small parts that can be dangerous for children. Children should always be under direct adult supervision while using this product.
- Do not discard any of the packaging until you have checked that you have all of the parts and fittings required.
- Carefully remove the contents from the package. If any parts are missing, broken, damaged, do not attempt to use the product until they have been obtained.
- Make sure that each bolt needed for all steps matches the corresponding figure ensure proper assembly.
- Please do not exceed the weight limitations of this item.
- Do not stand on or use any part of this item as a step ladder.
- Firmly secure all bolts, screws and knobs before use.
- Be aware that some parts are heavy and have sharp edges.
- Do not use or store this item in the proximity of open flame or flammable/combustible chemicals.

## CLEANING AND MAINTENANCE

- Clean frame with mild soapy water, rinse thoroughly. Dry frame parts completely. Do not use bleach, acid, or other solvents on the fabric and metal parts.
- If outdoor furniture is caught during a sudden rain storm, please make sure to drain any water that may have accumulated inside the frame and dry completely.
- We recommend the use of furniture covers to protect when not in use, and store properly during inclement weather and the winter/rainy seasons.
- Inspect and tighten all bolts on a regular basis to ensure proper performance and safety.
- In order to prolong the life and beauty of your outdoor furniture, we recommend storing it in a dry and protective area during off season periods.

## PARTS

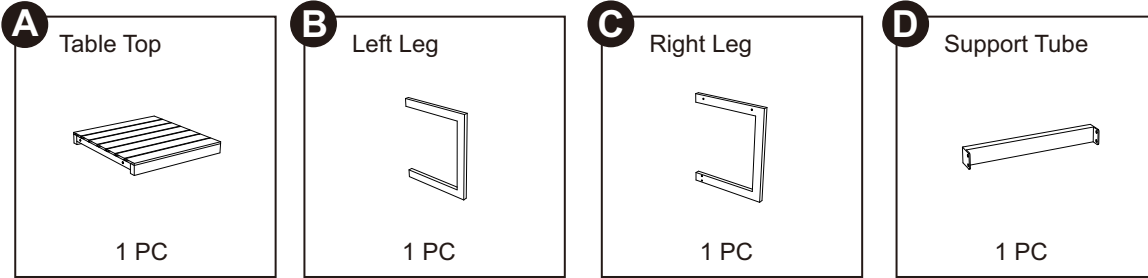

## HARDWARE

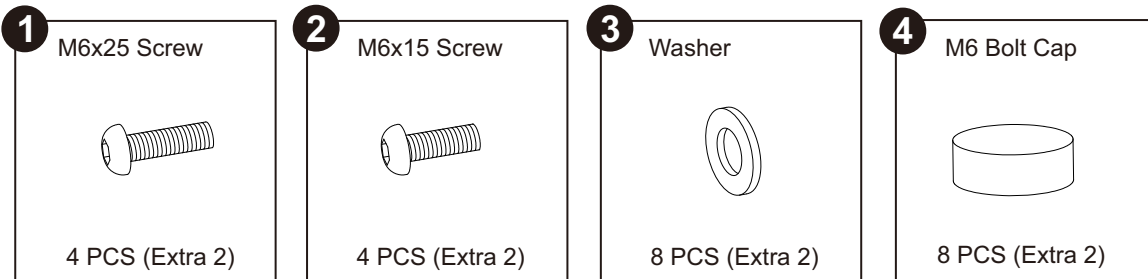

## TOOLS REQUIRED



Allen Wrench  
1PC

## PRODUCT ASSEMBLY

1

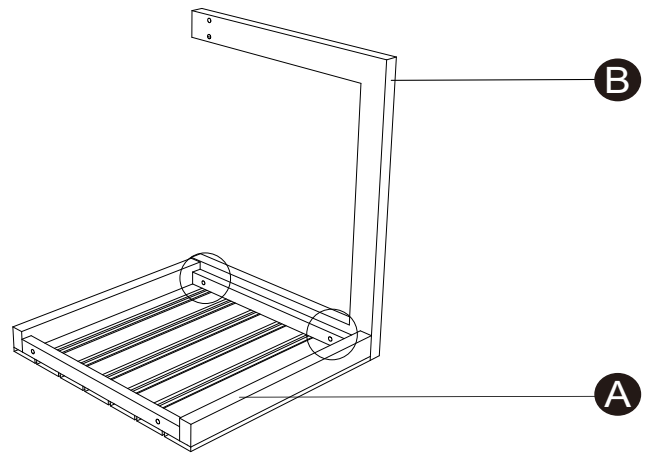
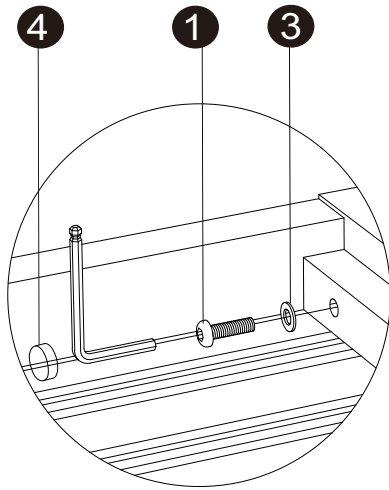

Attach left leg (B) to table top (A) using screws (1), washers (3), allen wrench and bolt caps (4).

NOTE: Please do not fully tighten until unit is fully assembled.

2

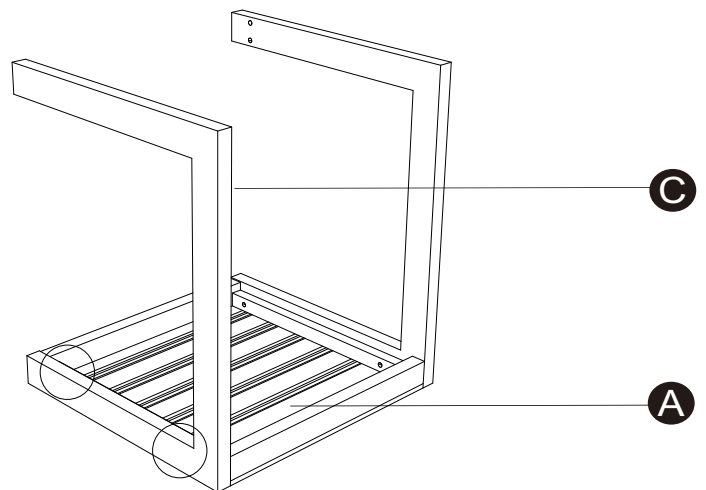
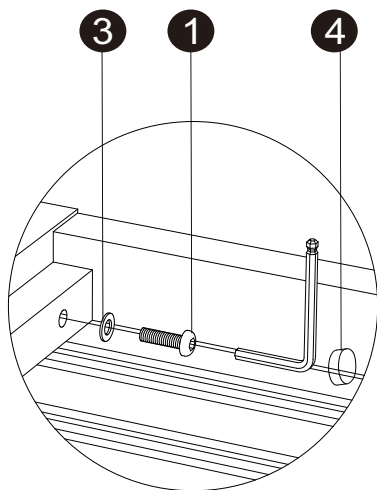

Attach right leg (C) to table top (A) using screws (1), washers (3), allen wrench and bolt caps (4).

NOTE: Please do not fully tighten until unit is fully assembled.

## PRODUCT ASSEMBLY

**3**

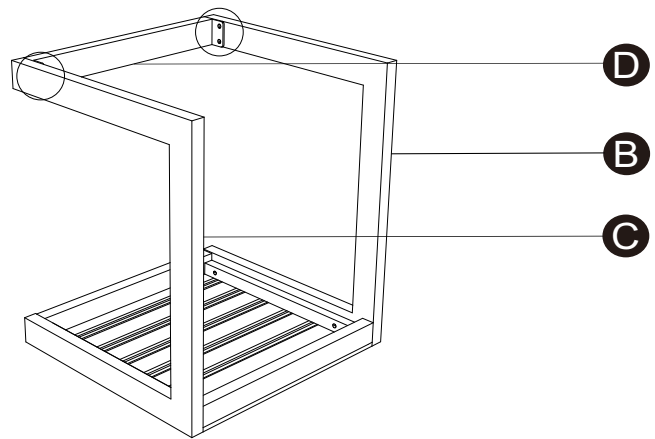
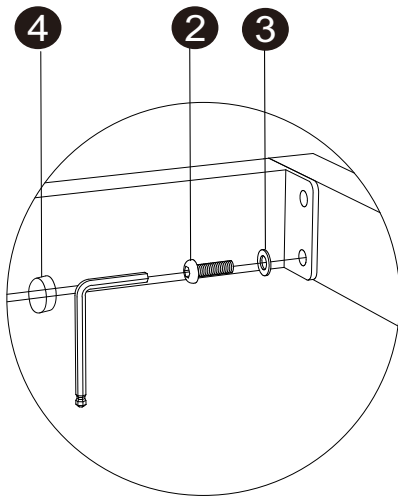

Attach support tube (D) to left leg (B) and right leg (C) using screws (2), washers (3), allen wrench and bolt caps (4).

NOTE: Please fully tighten all bolts at this time.

**2**

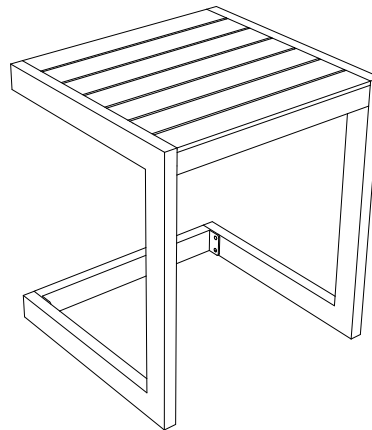

Carefully turn unit upright.  
ENJOY YOUR PRODUCT NOW!