

# Installation instruction

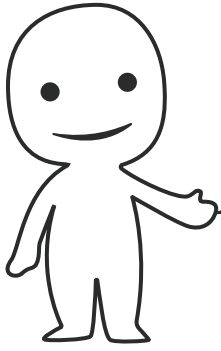

Please prepare the following tools

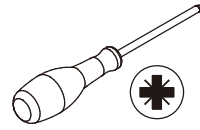

When installing, please carefully confirm whether each screw corresponds to the manual, accessories with similar shapes can be distinguished by size

A x 26

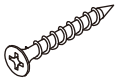

Ø4 x 30 mm

B x 30

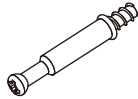

Ø6 x 35 mm

C x 34



Ø15 x 9 mm

D x 32



Ø8 x 30 mm

E x 78



Ø3.5 x 14 mm

F x 2

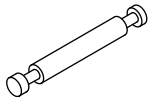

Ø6 x 60 mm

G x 8

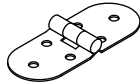

H x 36

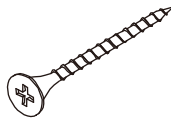

Ø4 x 35 mm

J x 14

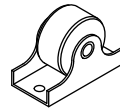

K x 3

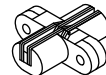

L x 2

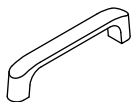

M x 1

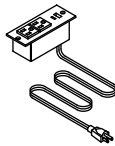

N x 28



Ø4 x 14 mm

P x 2

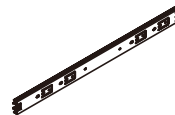

450 mm

Q x 2



Ø4 x 16 mm

R x 3

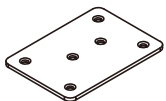

S x 12



Ø4 x 20 mm

T x 2

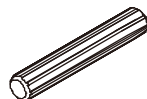

Ø8 x 50 mm

U x 2



V x 4



Ø4 x 20 mm

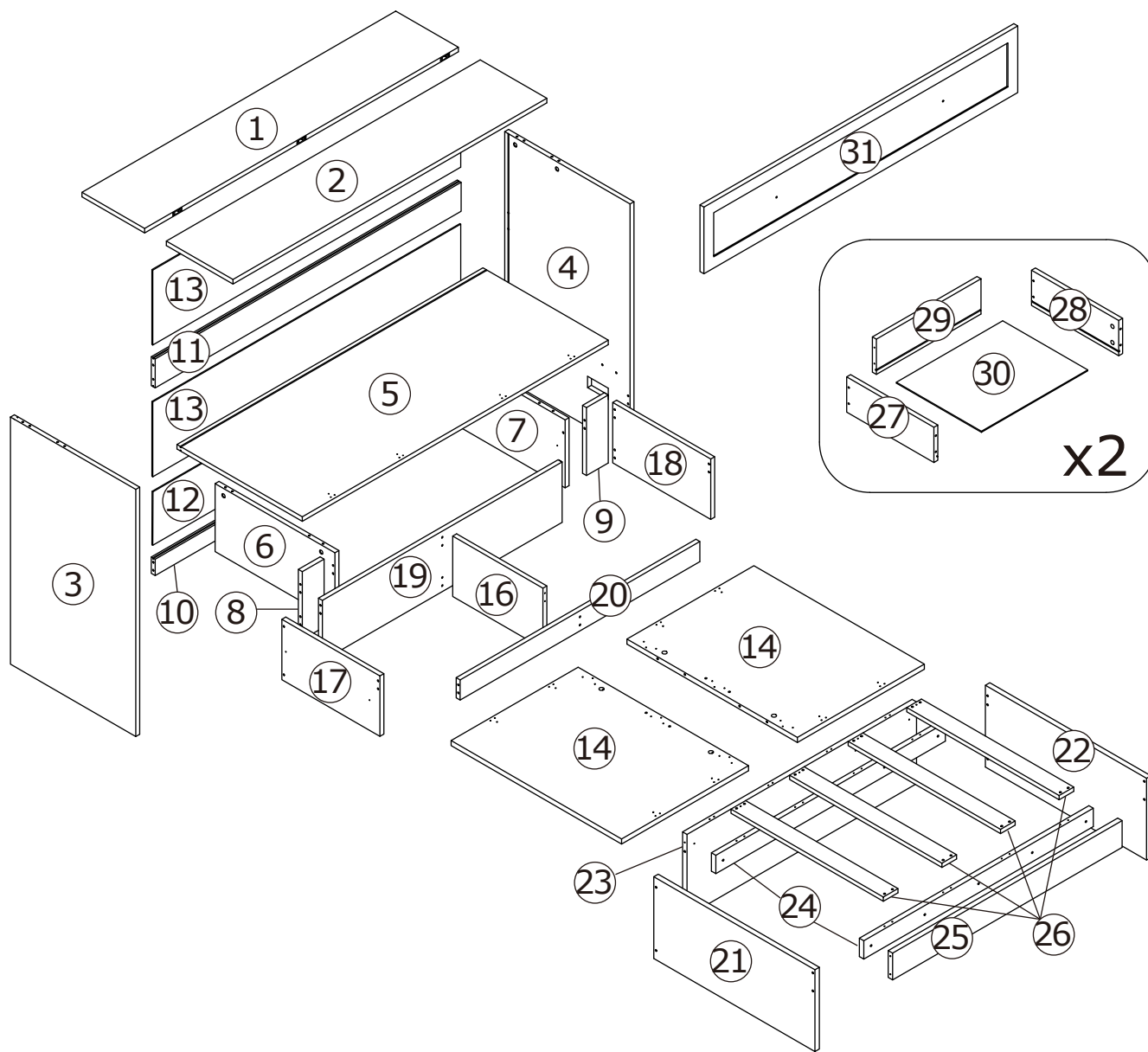

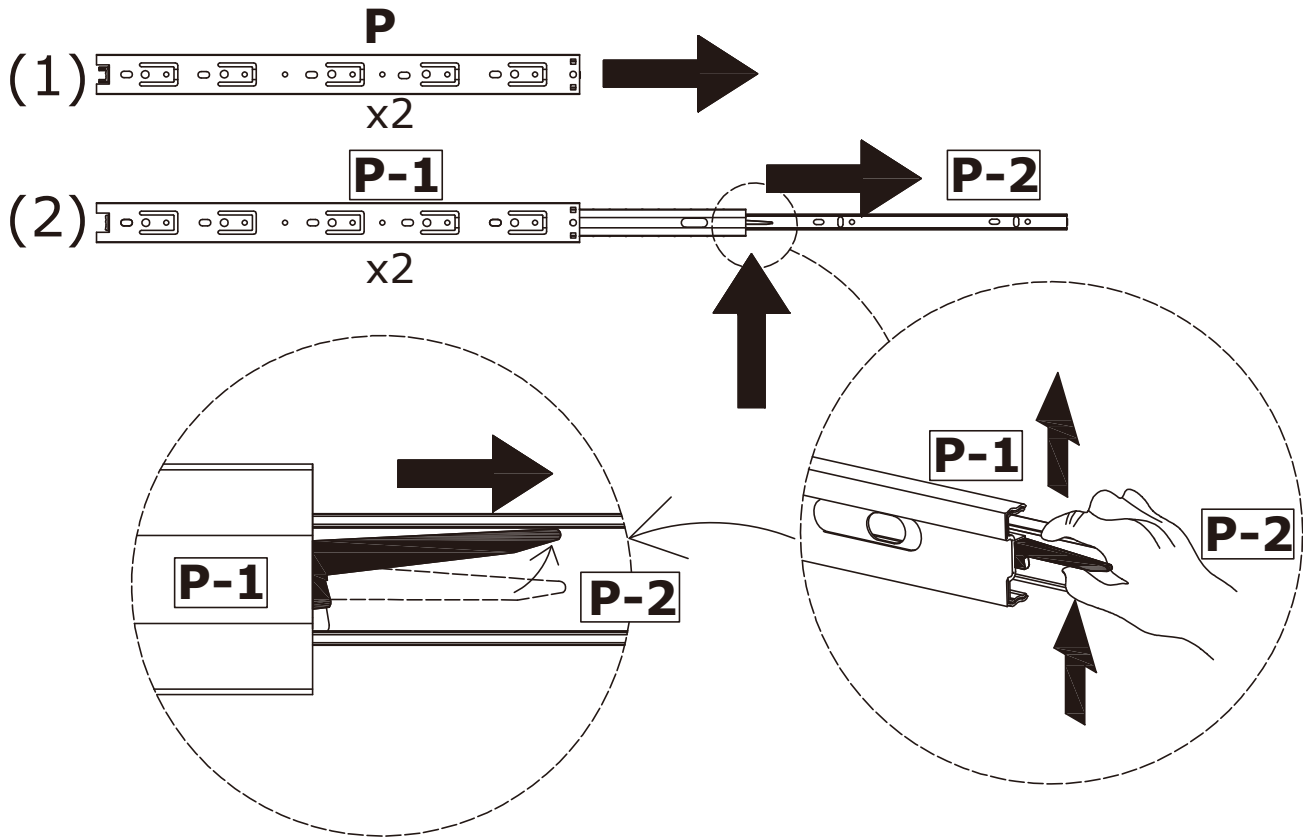

Move the black paddle upward and pull out (P-2) to the right.

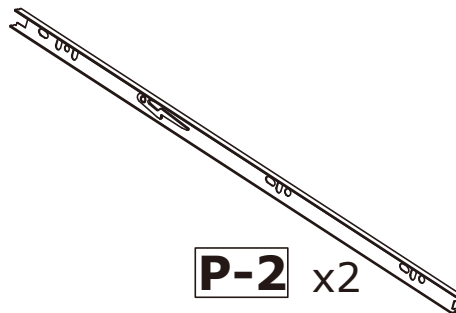
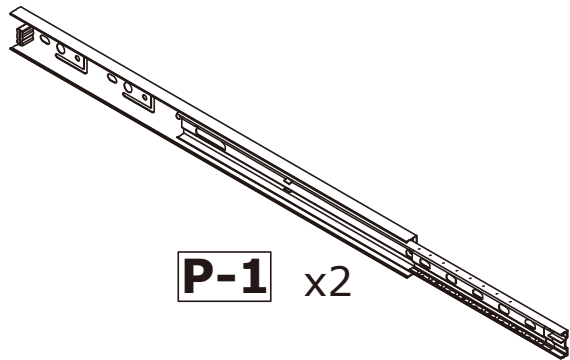
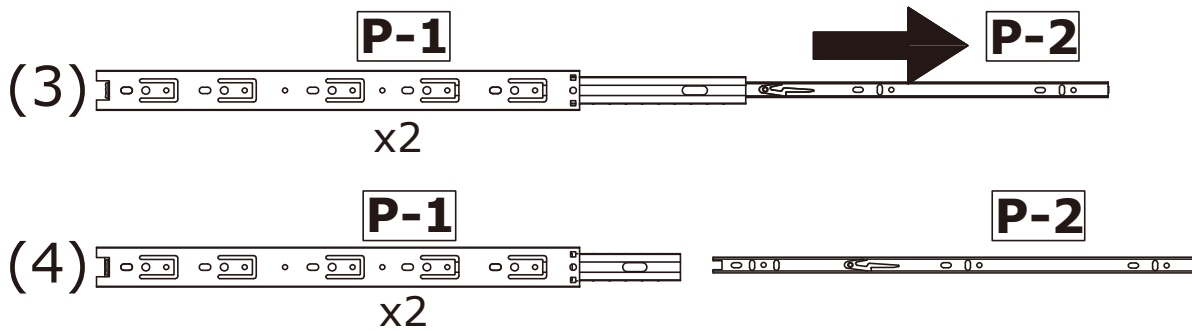

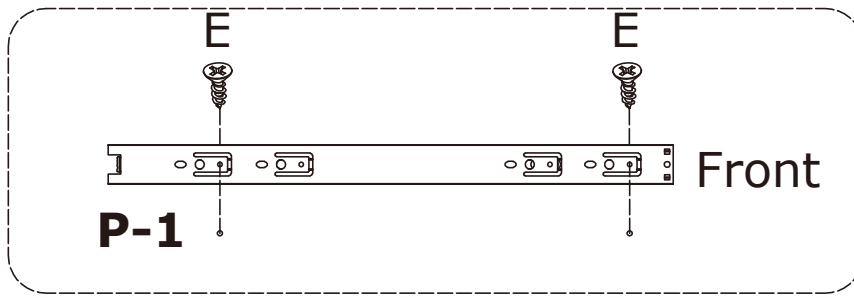

(1)

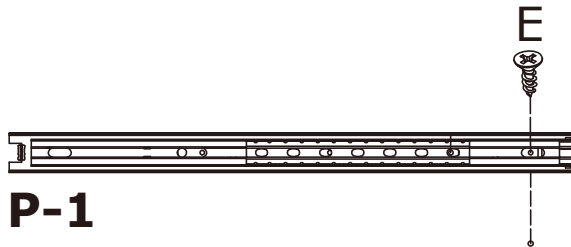

Refer to the figure above,  
lock the first, second and fifth holes first

(3)

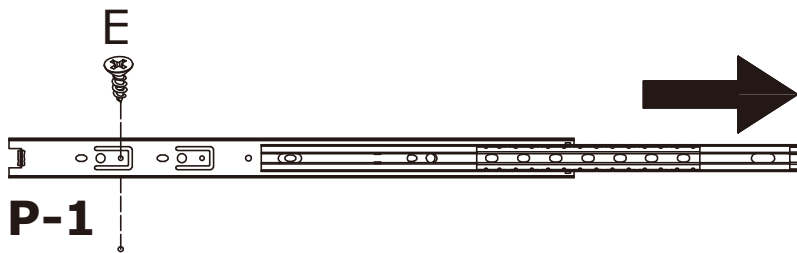

Refer to the figure above,  
Continue to open the second section and  
lock the fourth and sixth holes

1

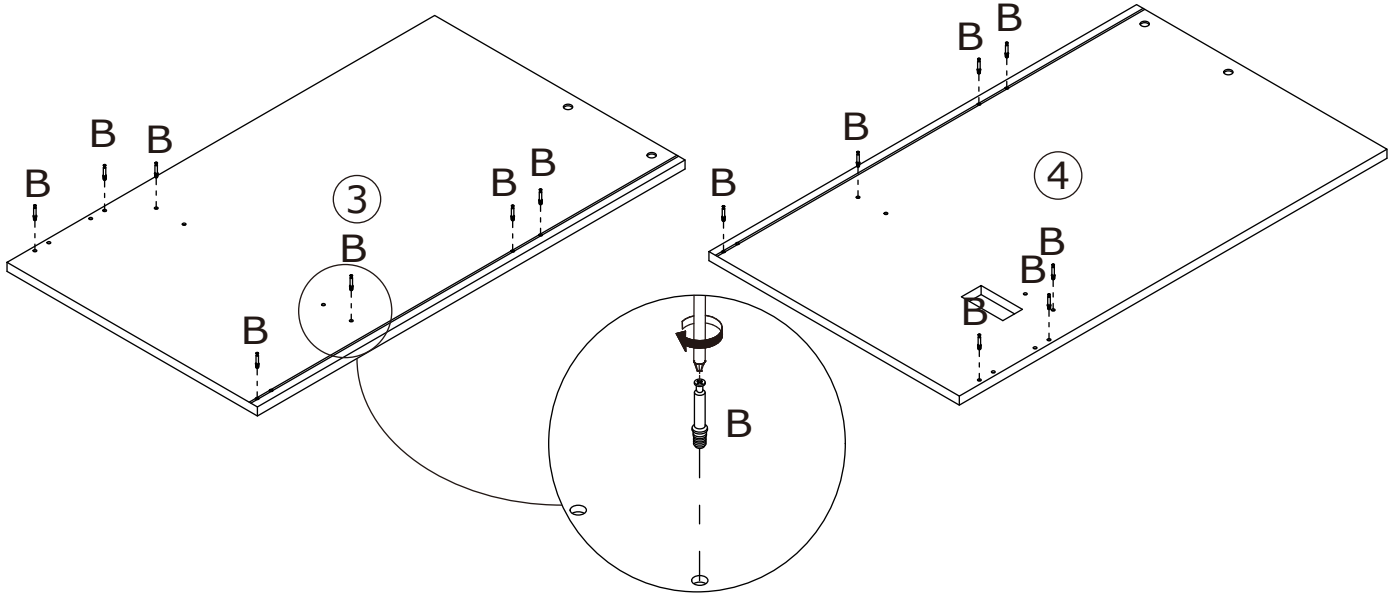
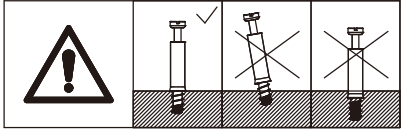
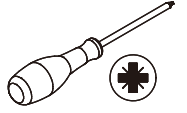
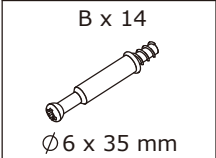

2

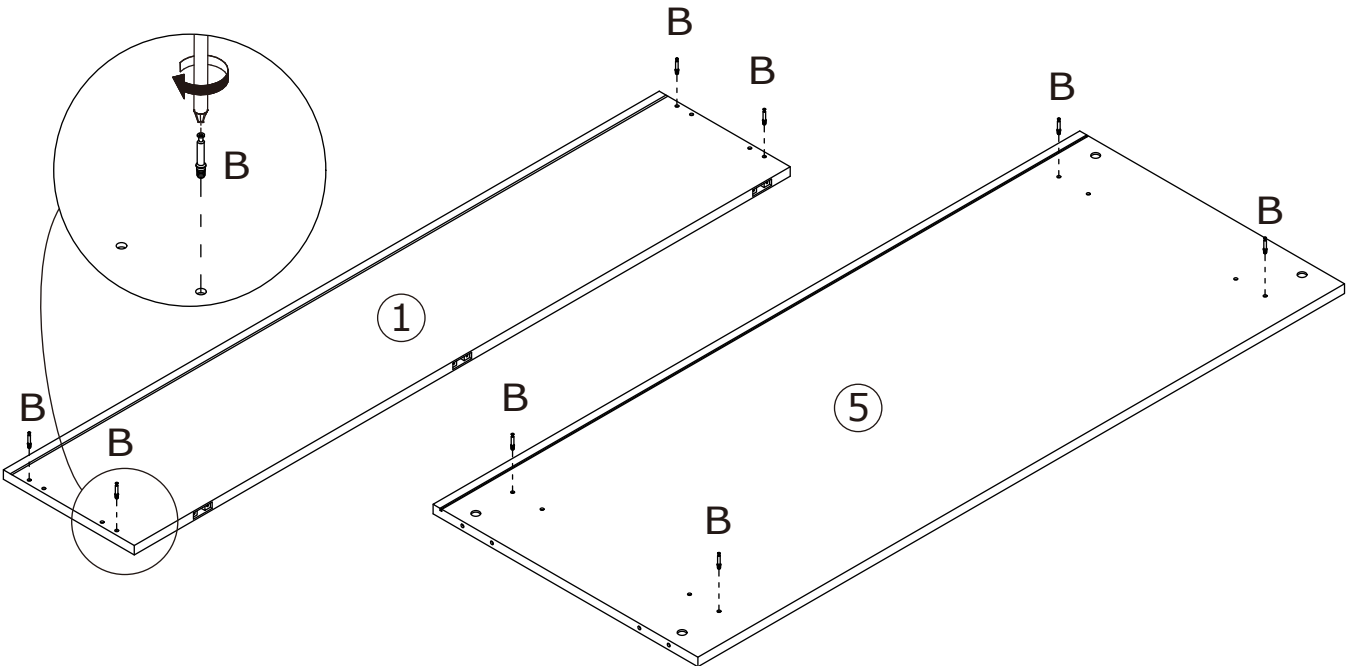
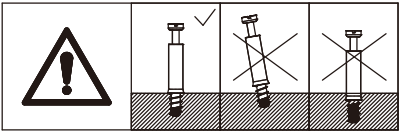
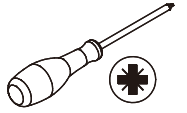
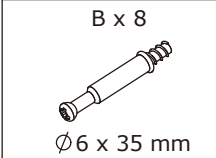

3

E x 4  
Ø 3.5 x 14 mm

(P-1) x 2  
450mm

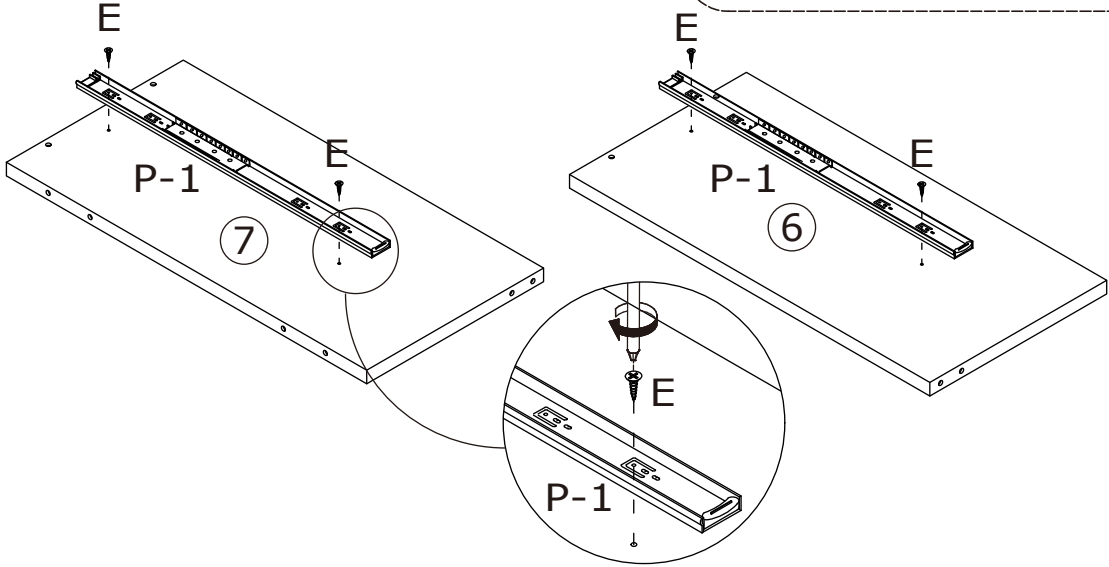
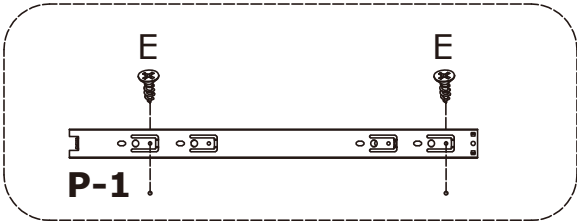
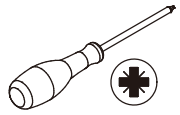

4

H x 4  
Ø 4 x 35 mm

D x 4  
Ø 8 x 30 mm

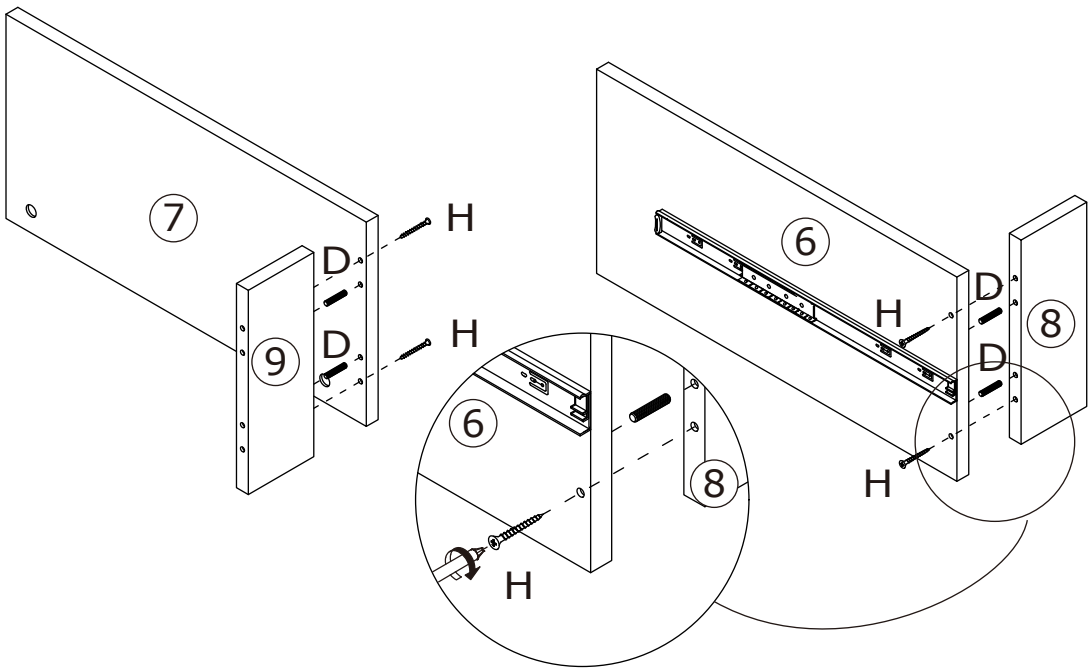
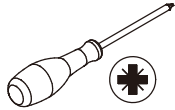

5

C x 4  
  
Ø 15 x 9 mm

D x 4  
  
Ø 8 x 30 mm

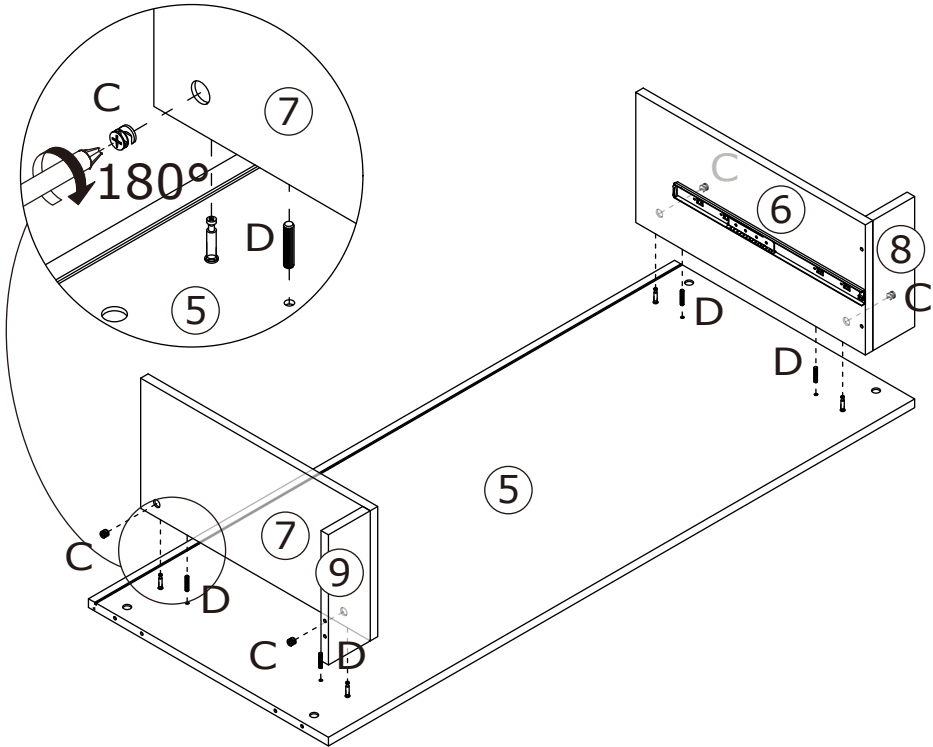

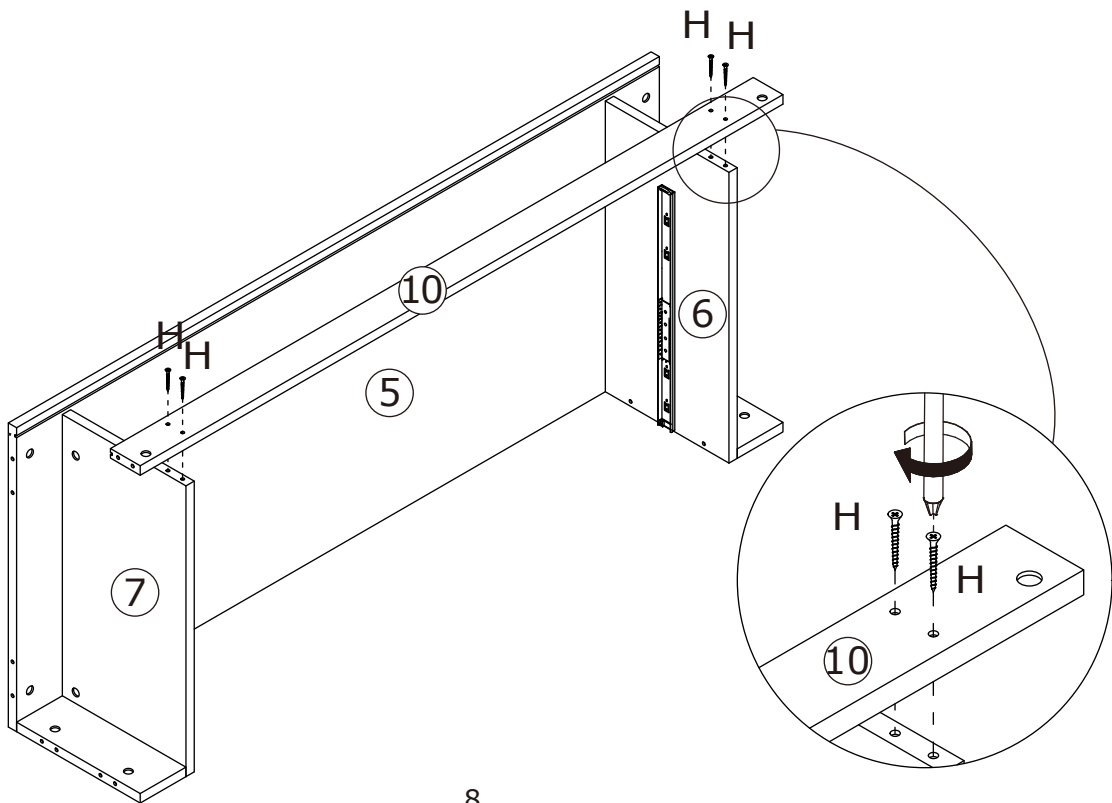

6

H x 4  
  
Ø 4 x 35 mm

7

C x 7  
  
Ø15 x 9 mm

D x 5  
  
Ø6 x 30 mm

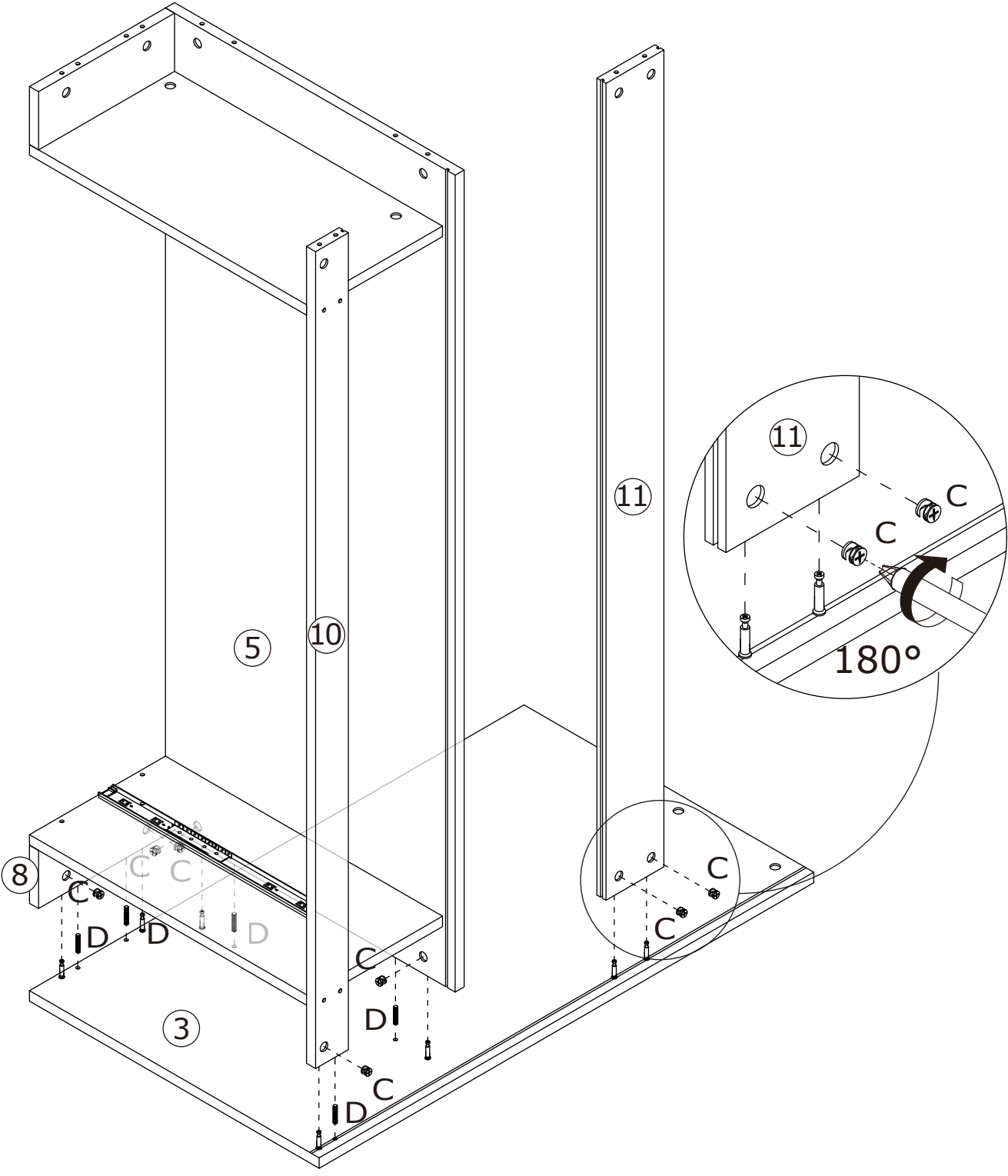
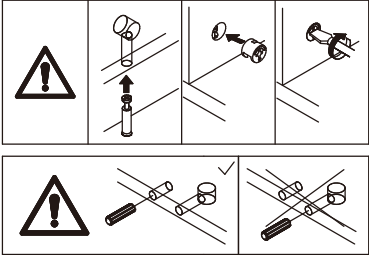
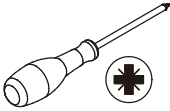

8

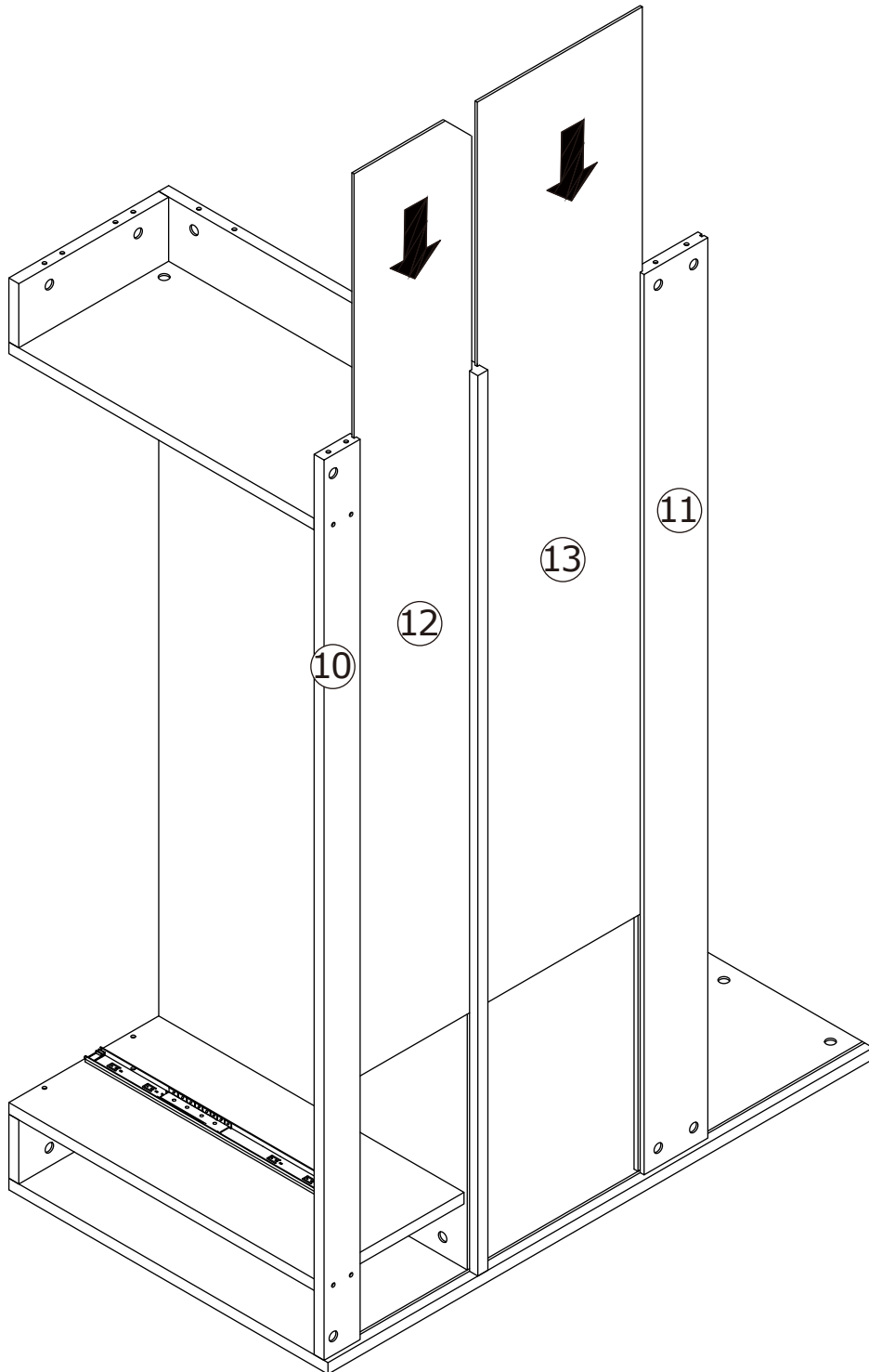

9

C x 7  
  
Ø 15 x 9 mm

D x 5  
  
Ø 8 x 30 mm

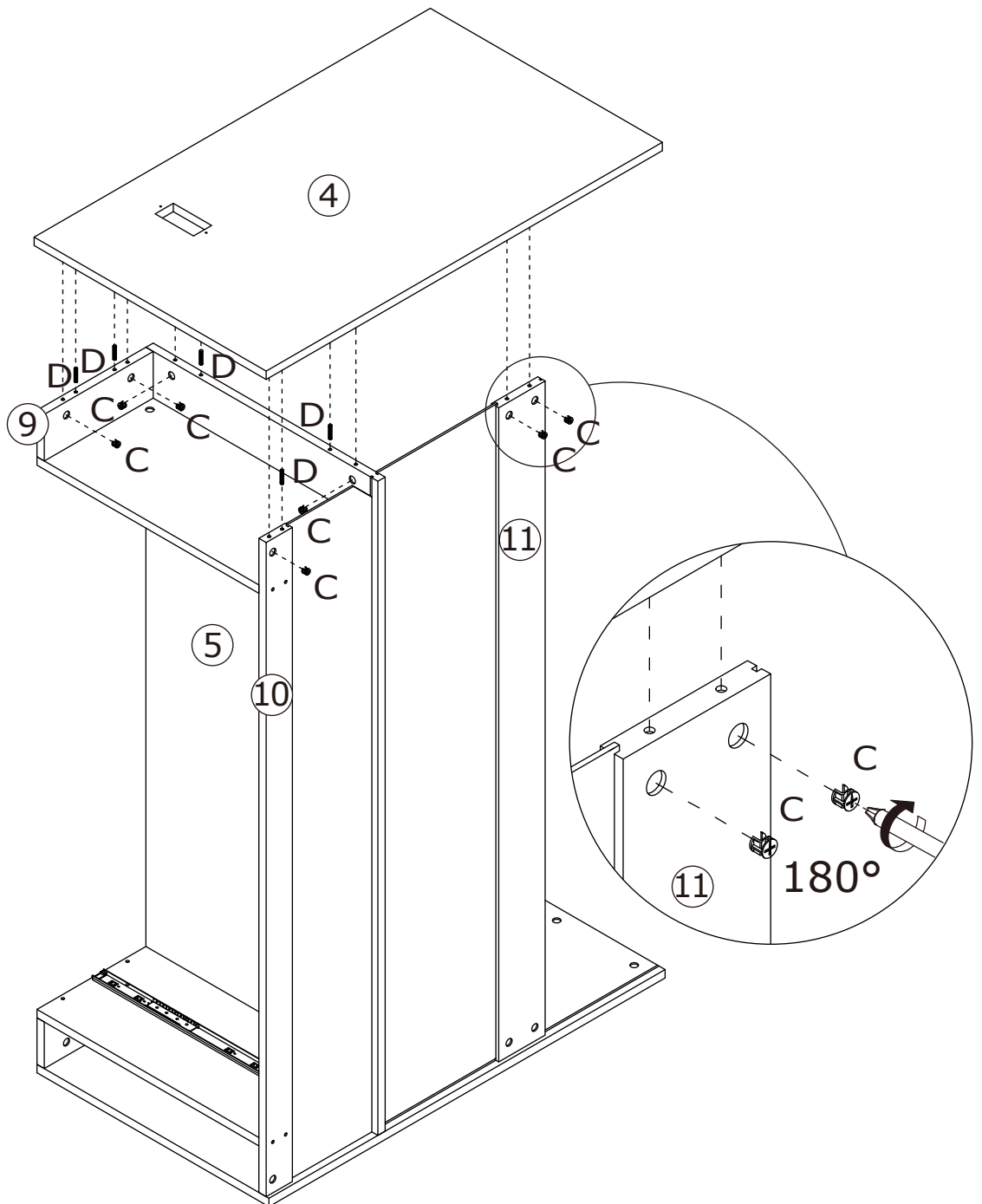
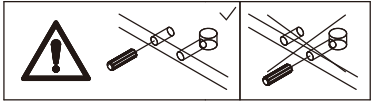
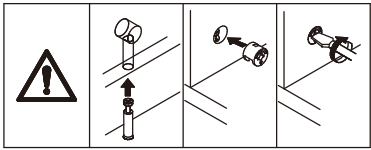

10

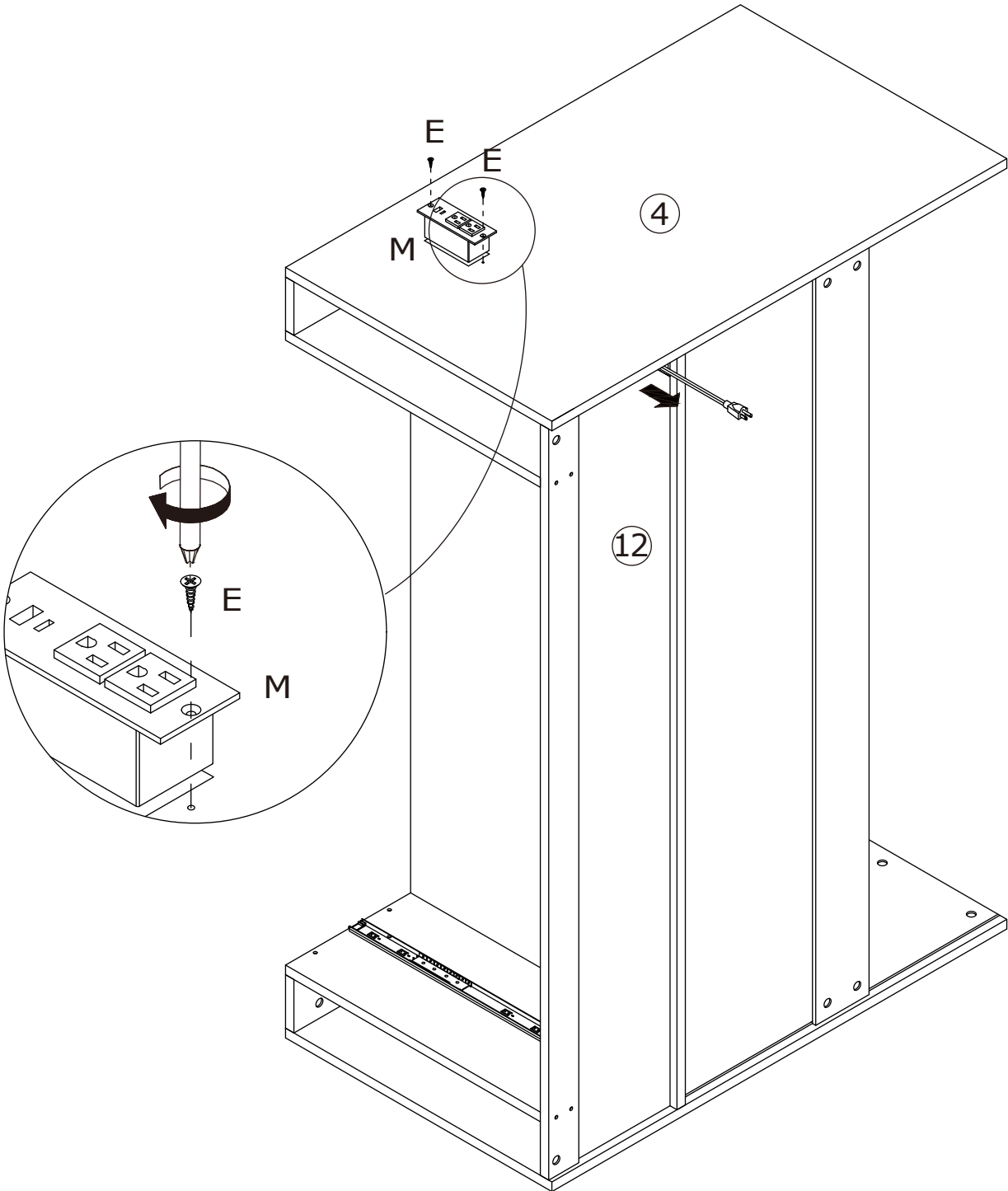
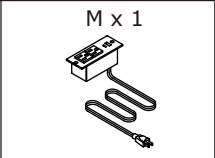
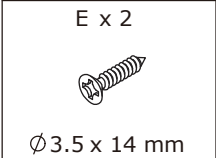

11

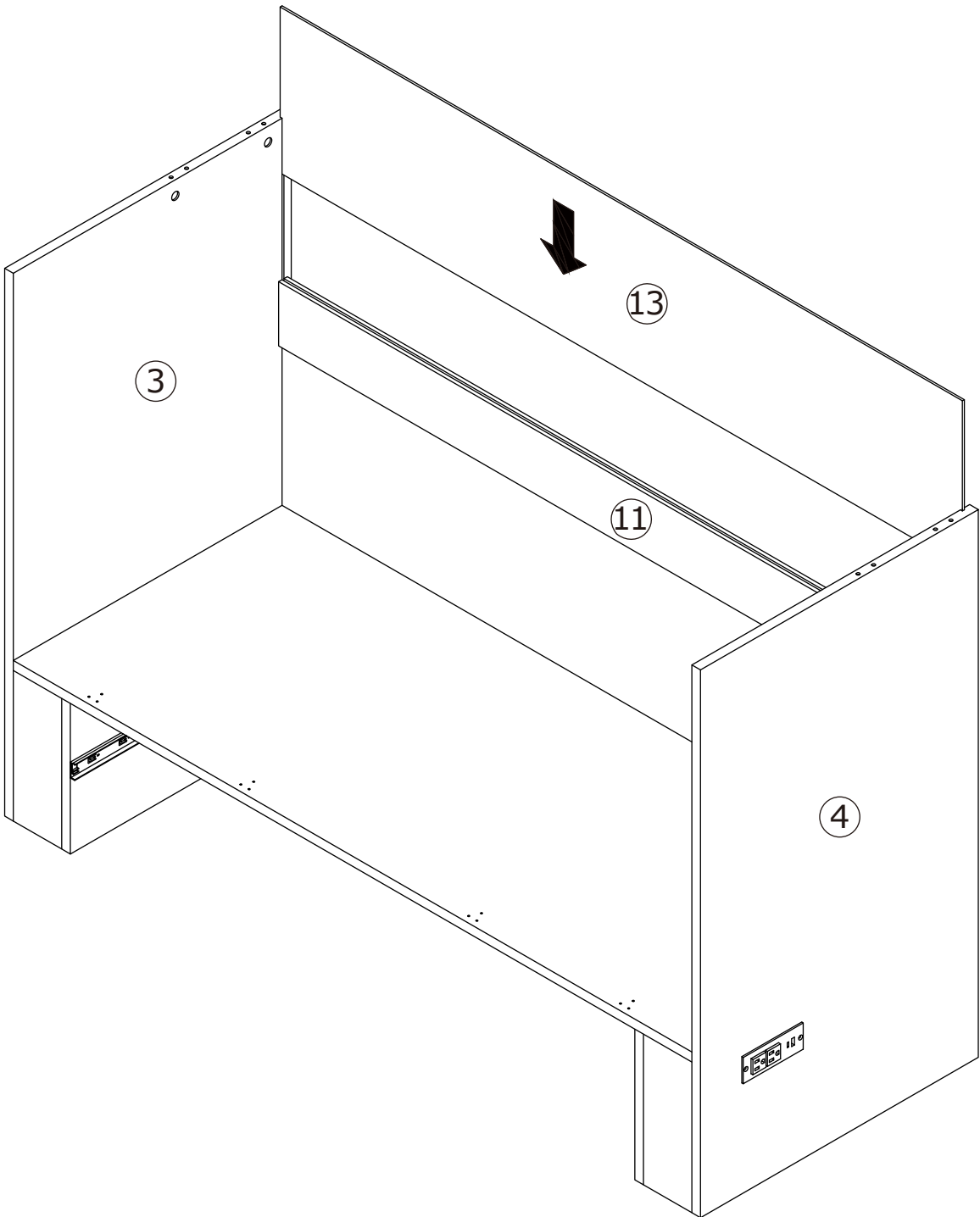

12

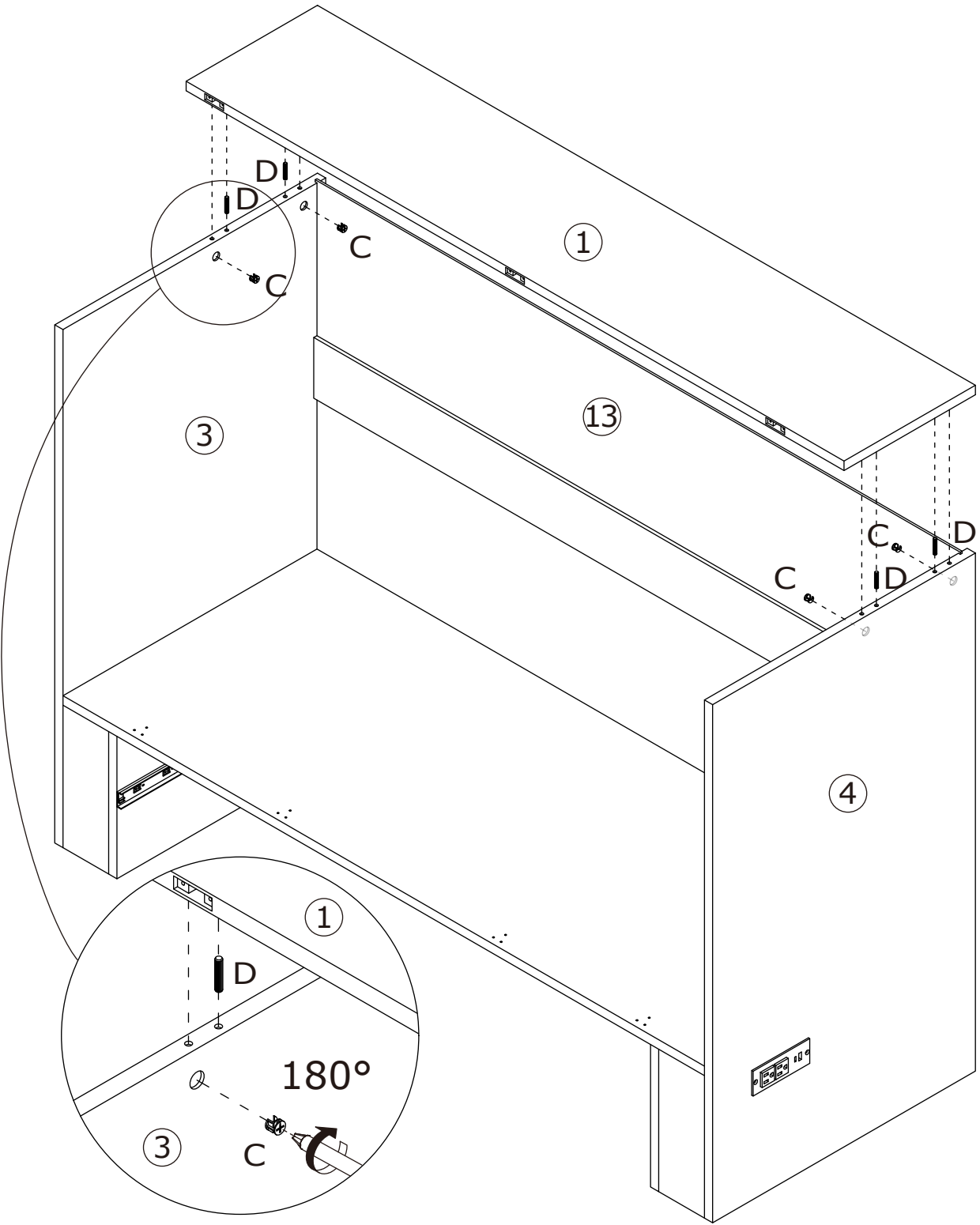
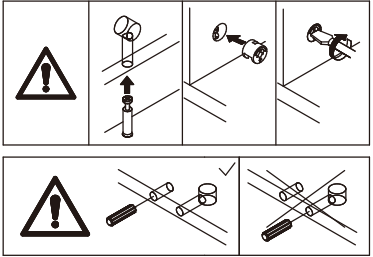
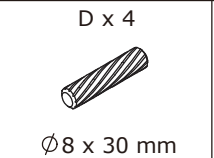
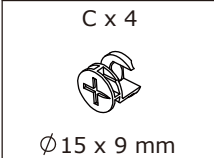

13

S x 12  
Ø 4 x 20 mm

K x 3

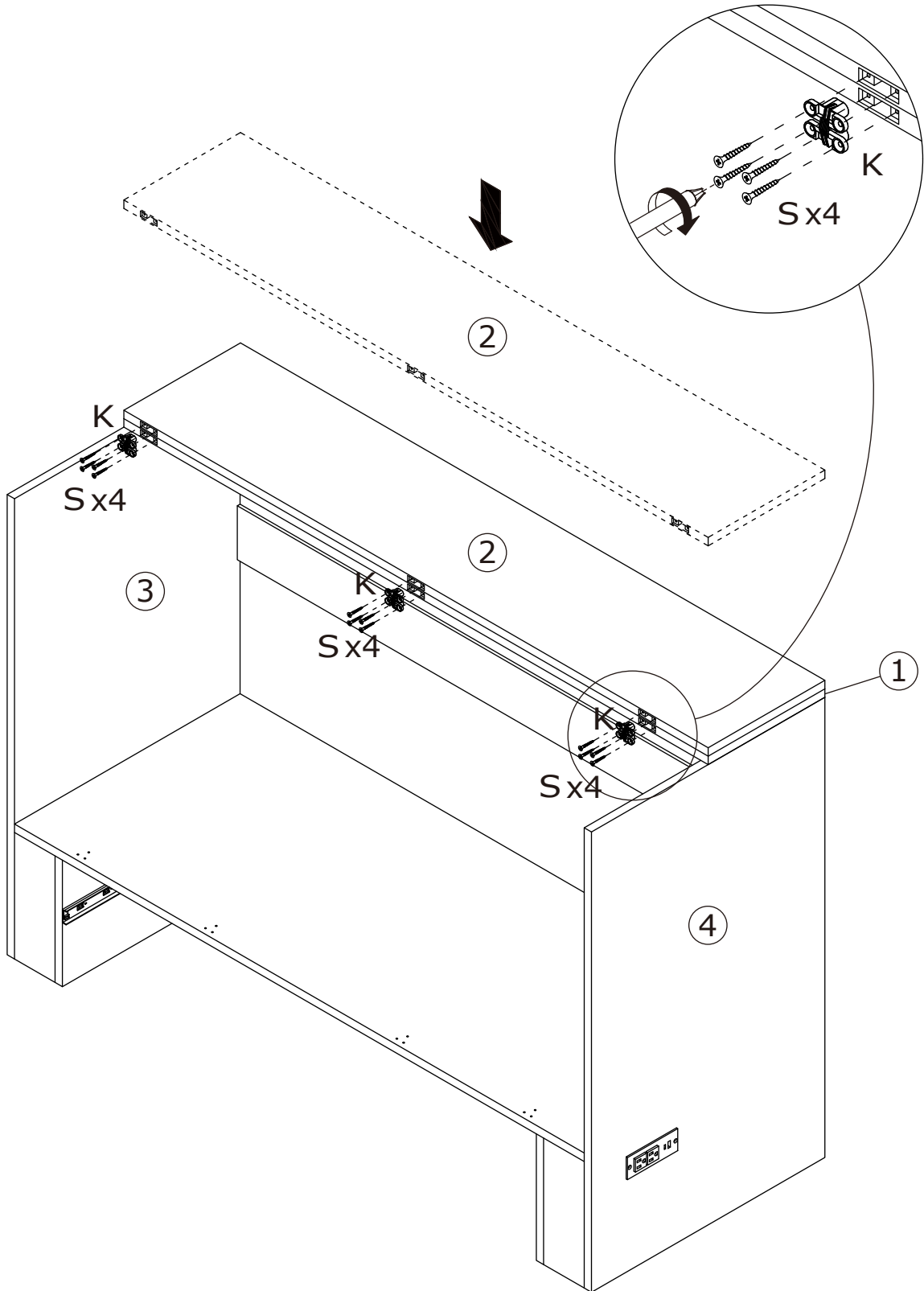

14

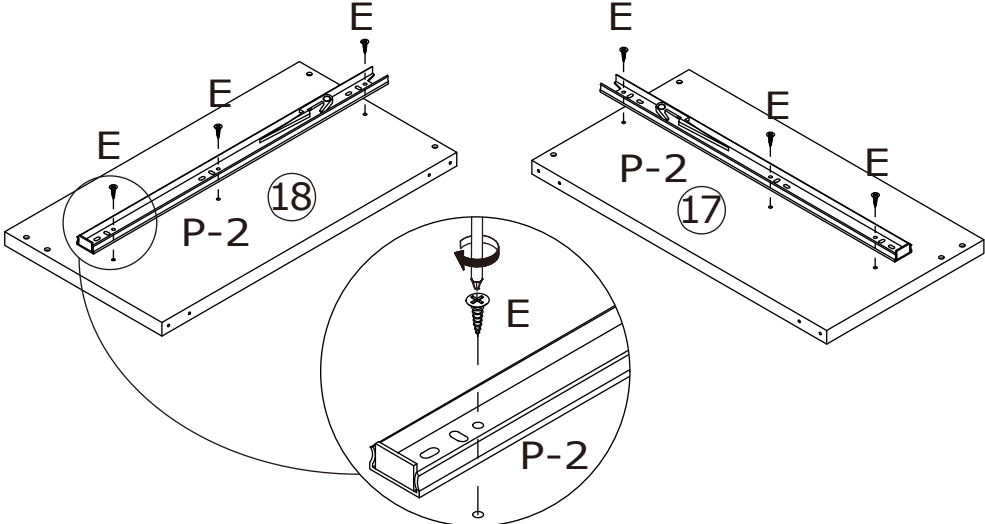
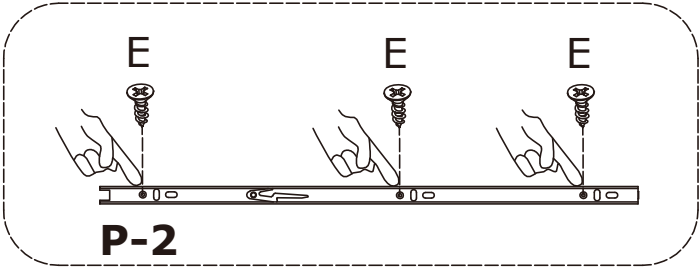
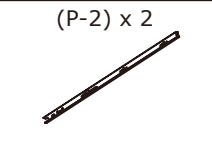
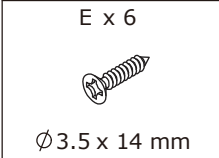

15

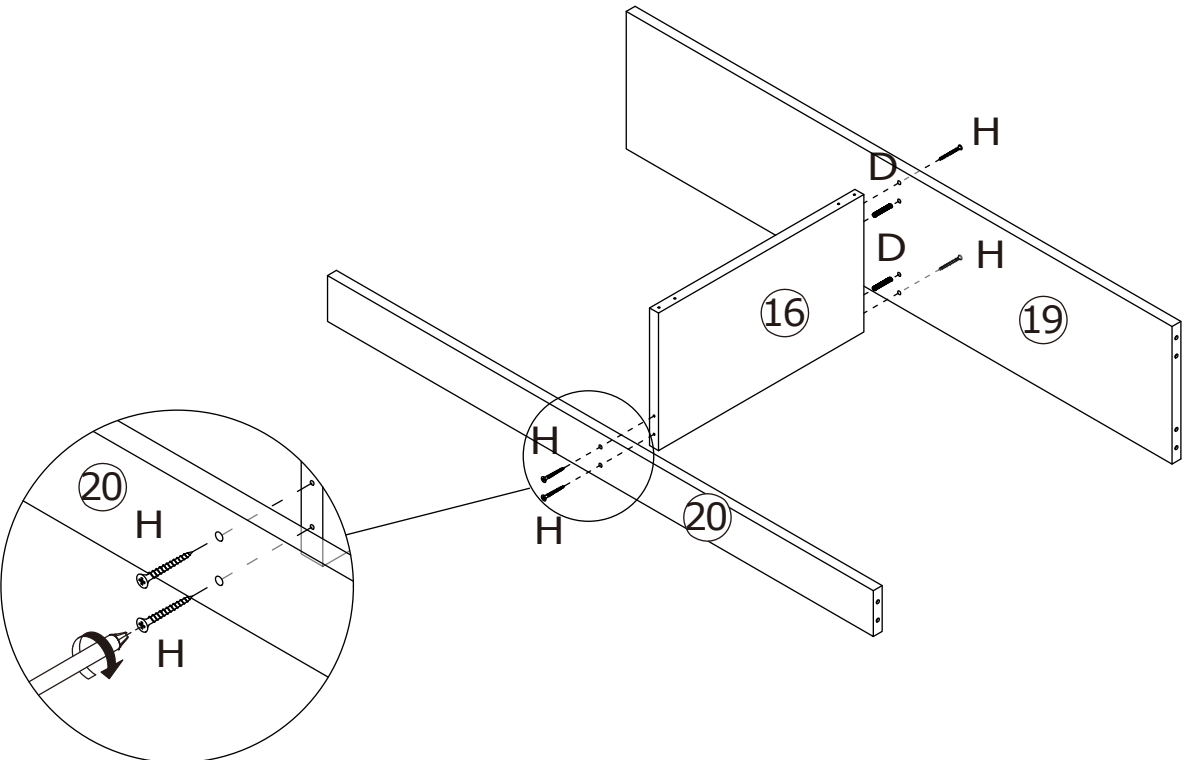
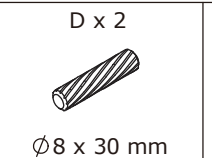
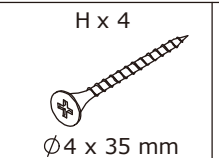

16

<p>H x 8</p>  <p>Ø4 x 35 mm</p>	<p>D x 4</p>  <p>Ø8 x 30 mm</p>	
--	--	---

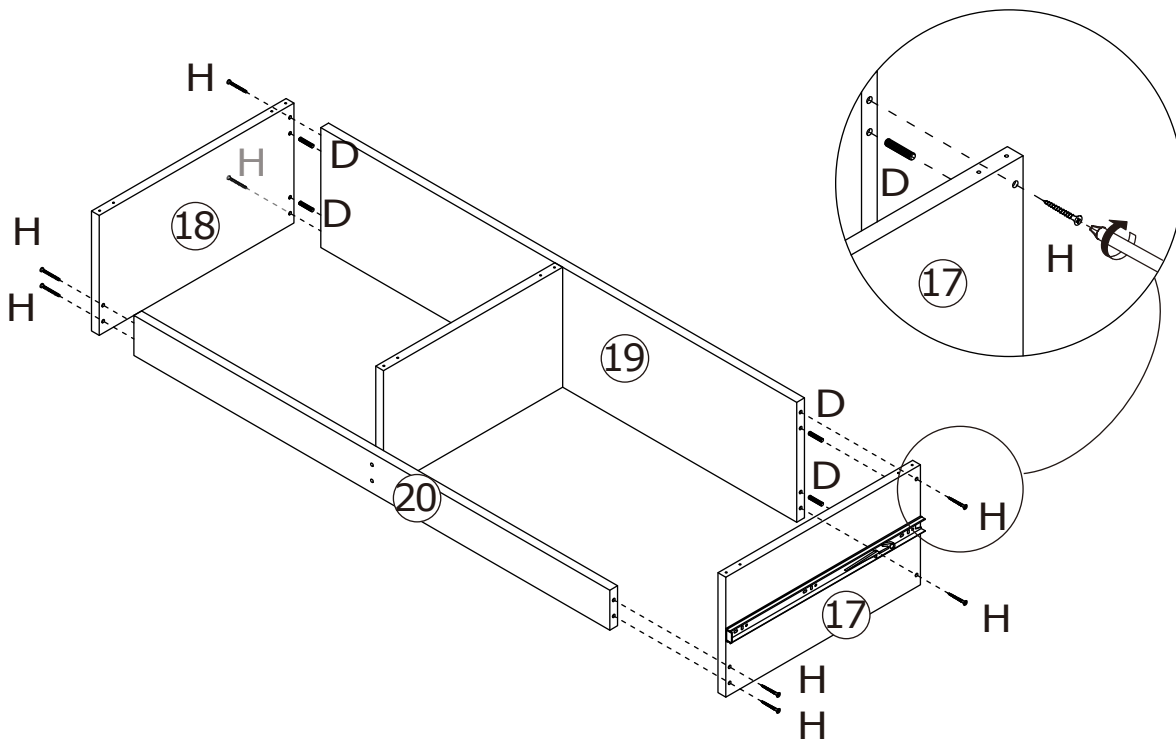

17

<p>N x 12</p>  <p>Ø4 x 14 mm</p>	<p>J x 6</p> 	
---	--	---

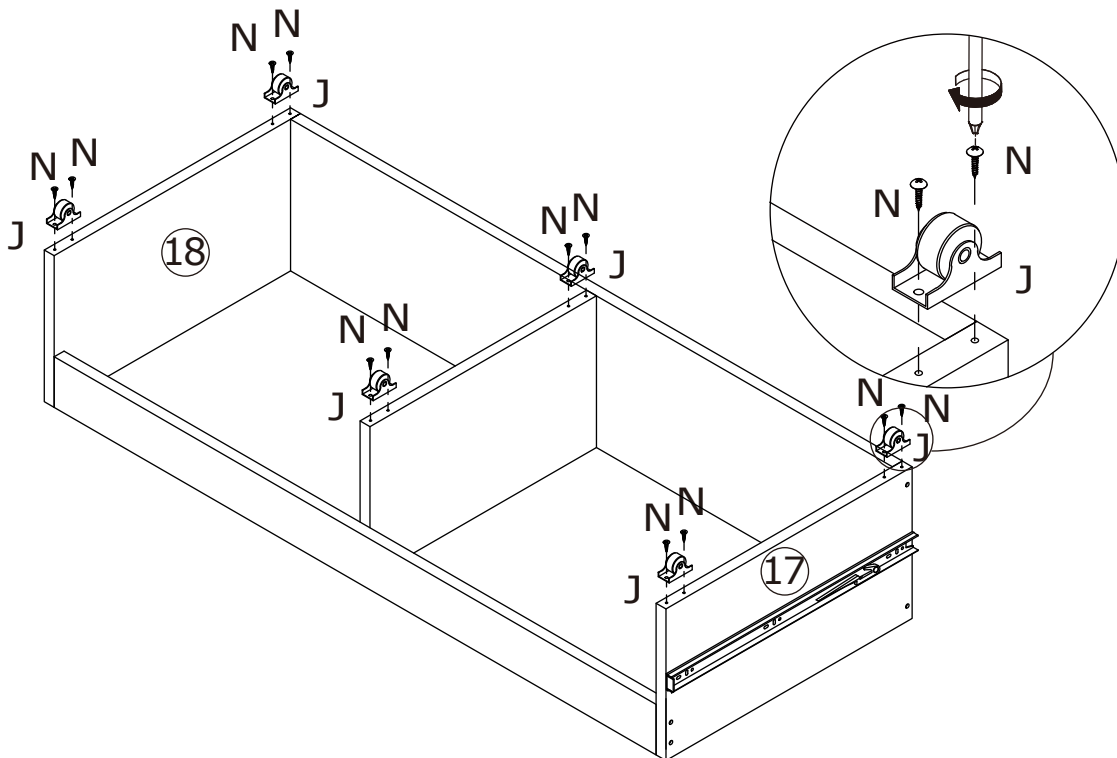

18

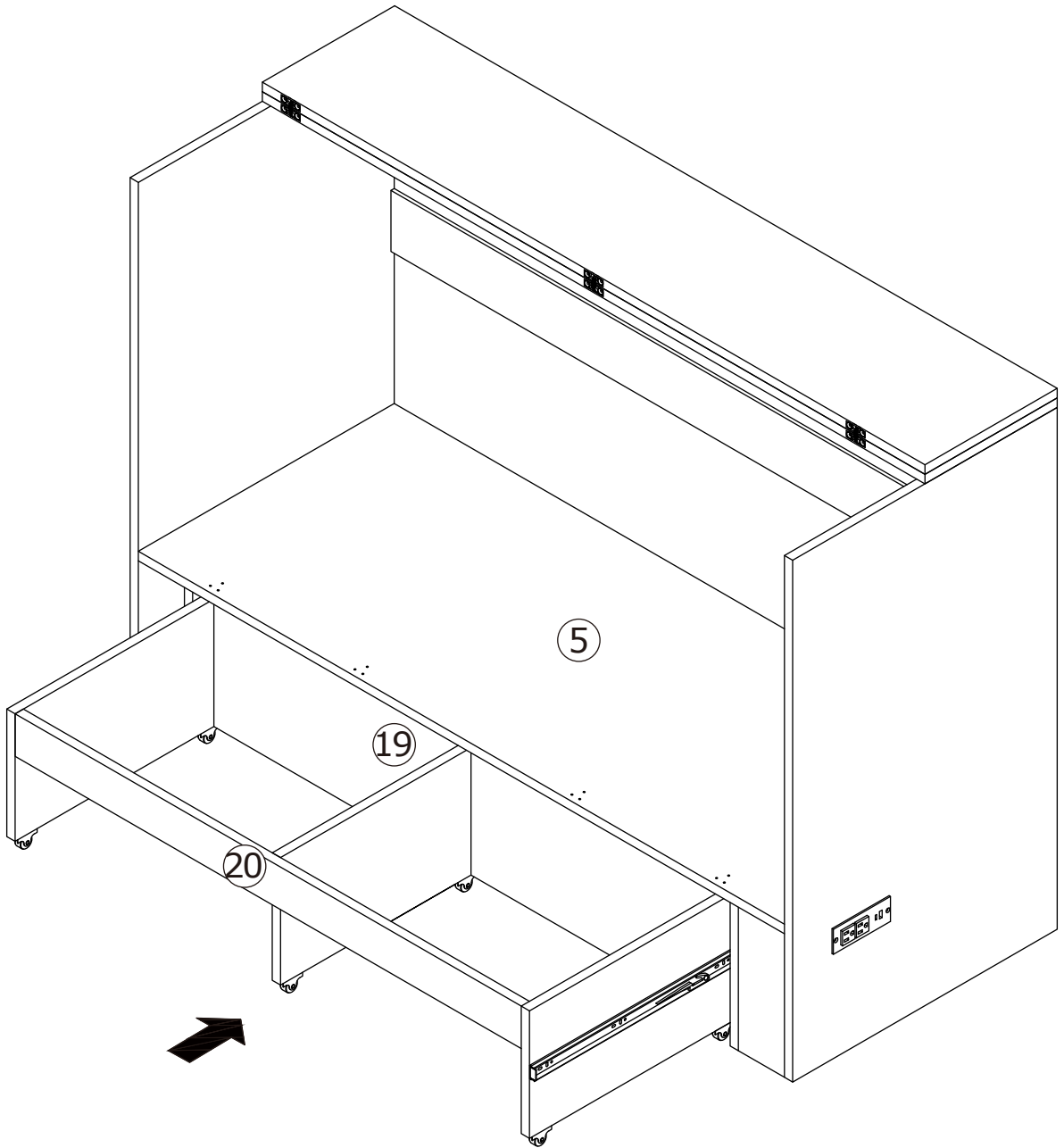

19

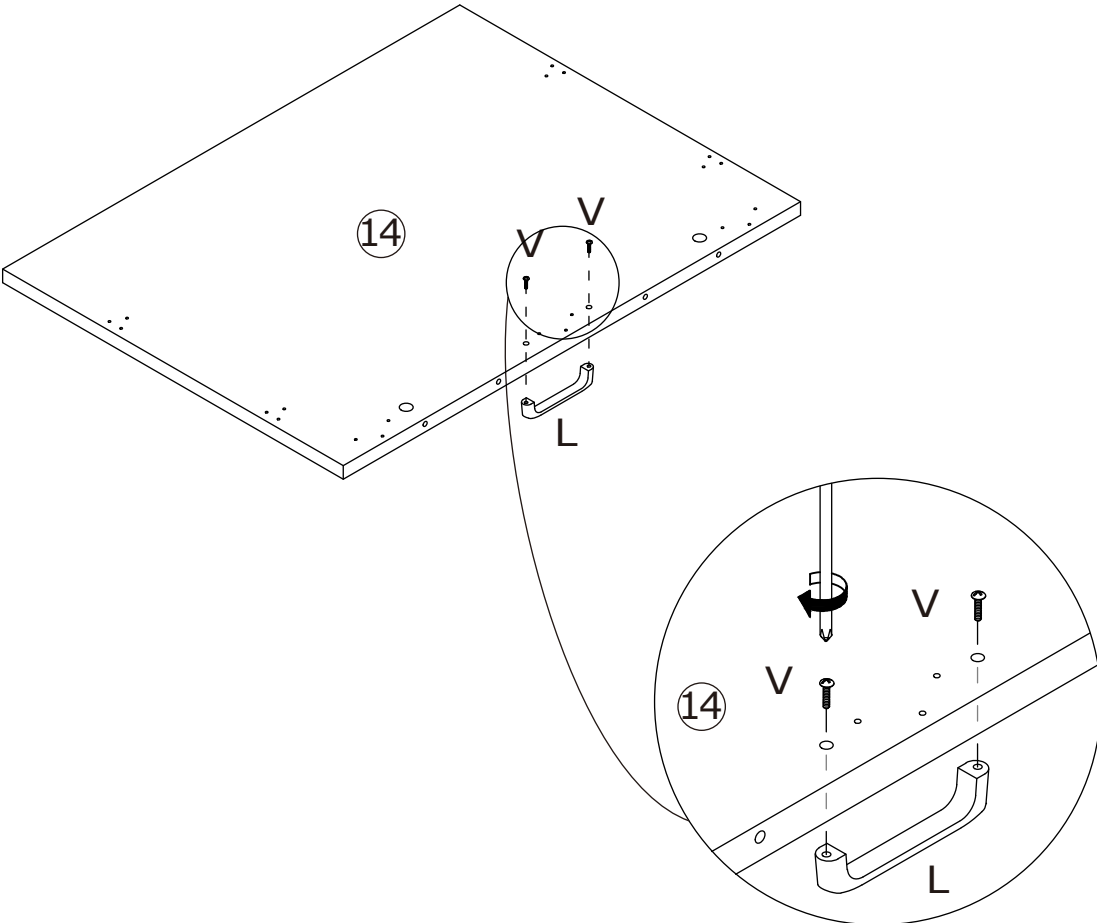
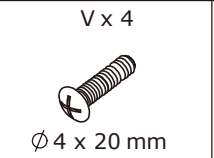
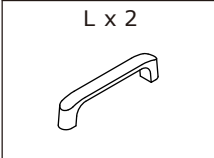

x2

20

C x 4  
Ø 15 x 9 mm

T x 2  
Ø 8 x 50 mm

F x 2  
Ø 6 x 60 mm

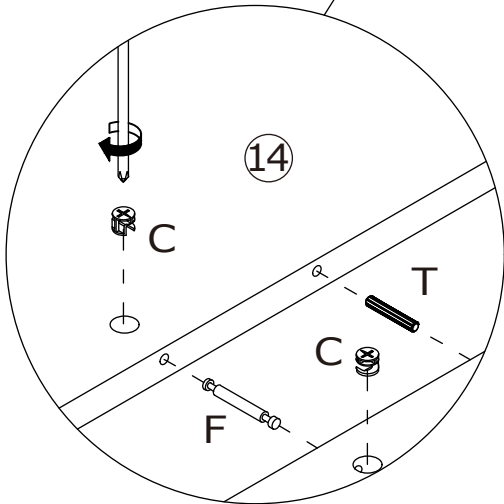
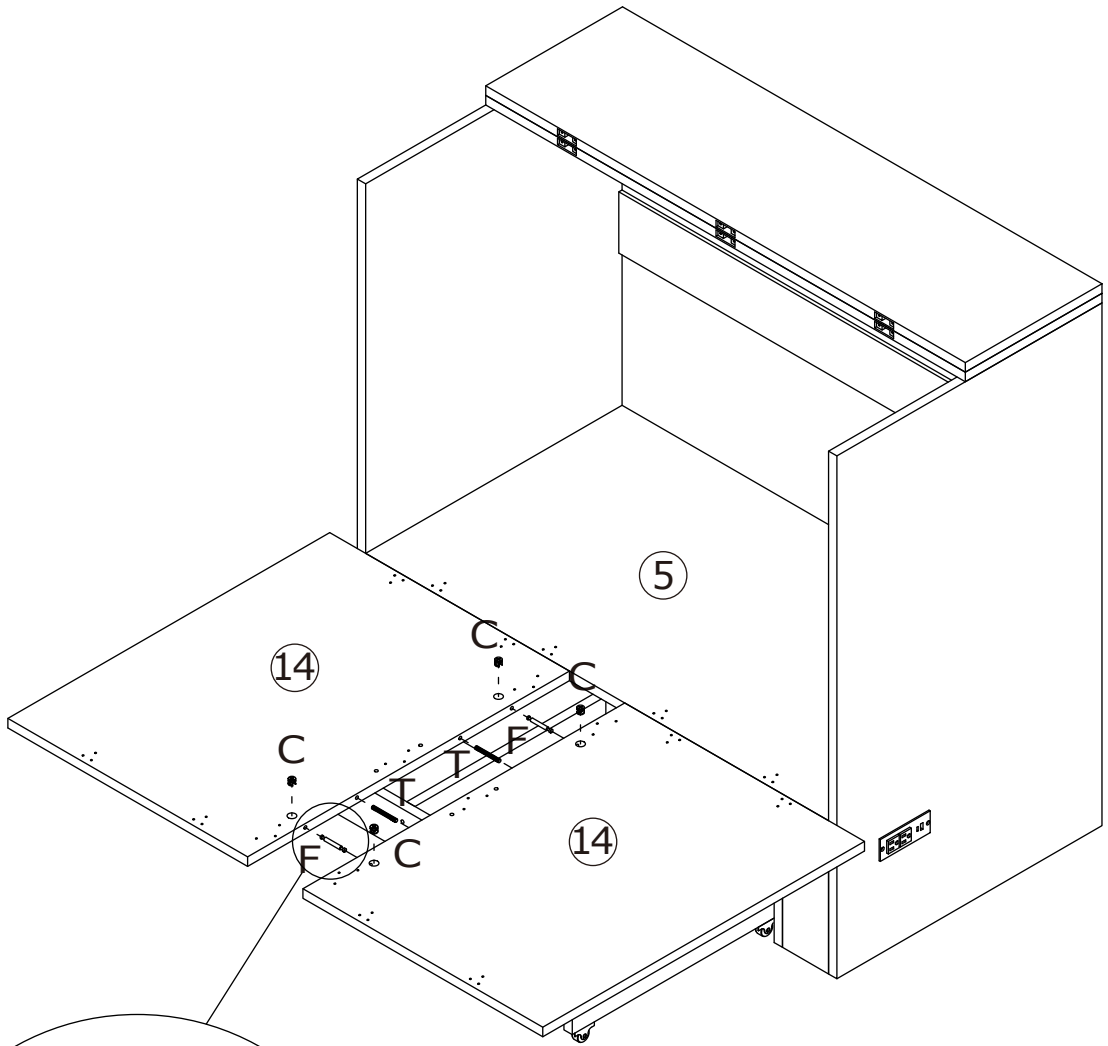
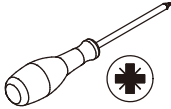

21

E x 24  
  
Ø 3.5 x 14 mm

G x 4  

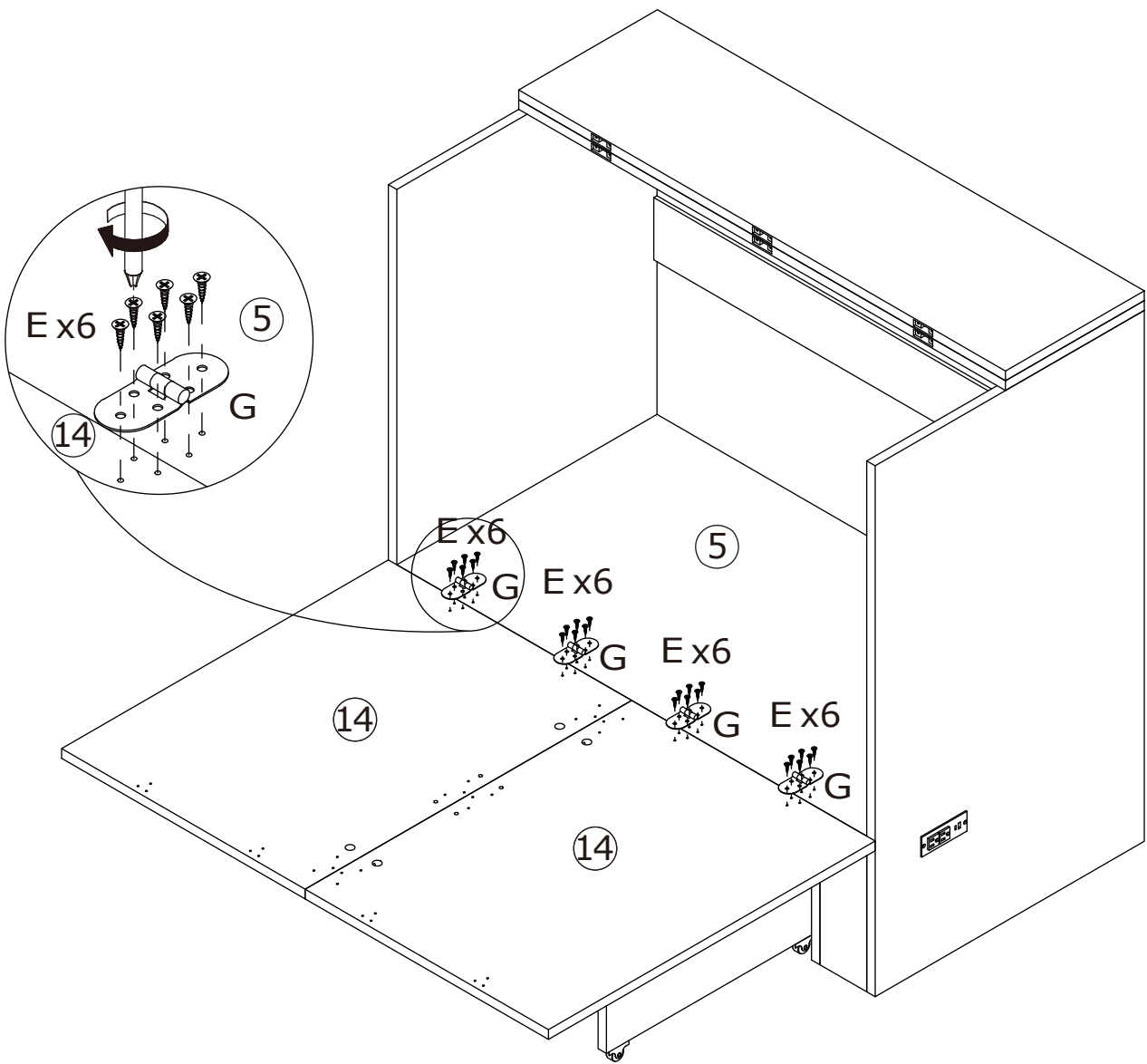

22

E x 18



Ø 3.5 x 14 mm

R x 3

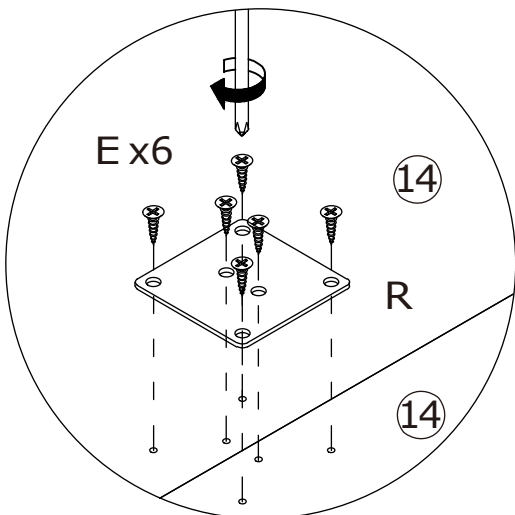
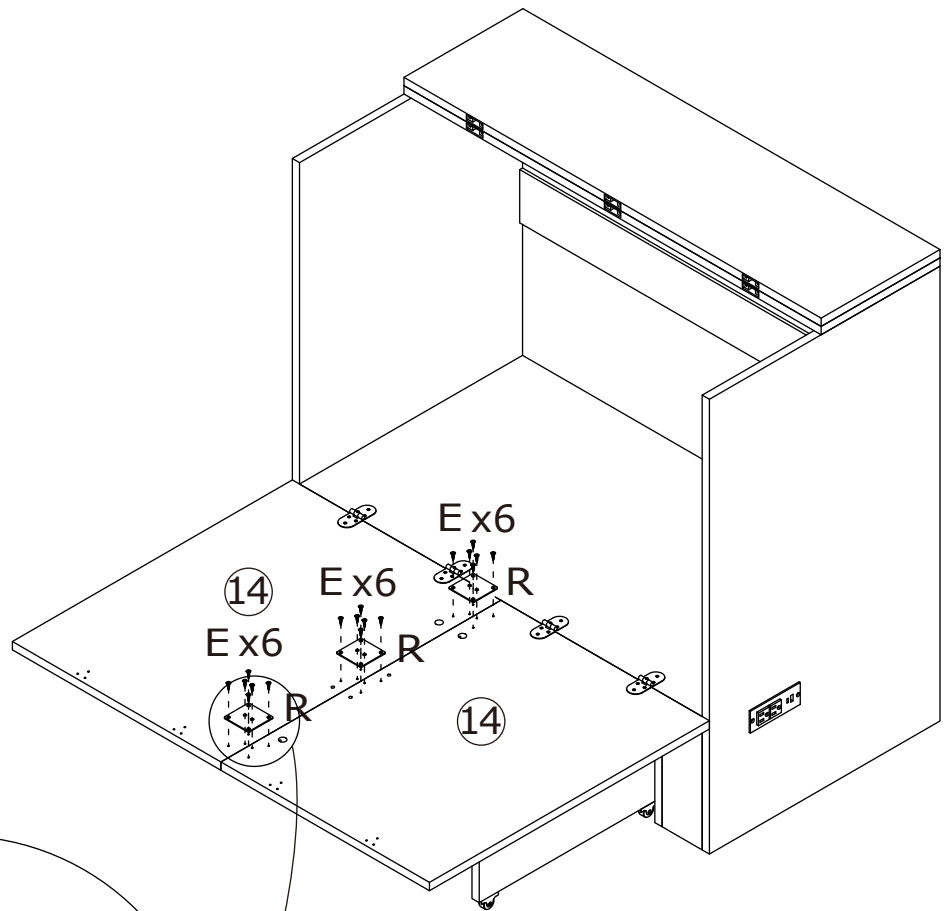
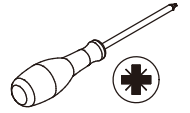
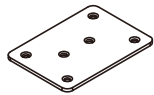

23

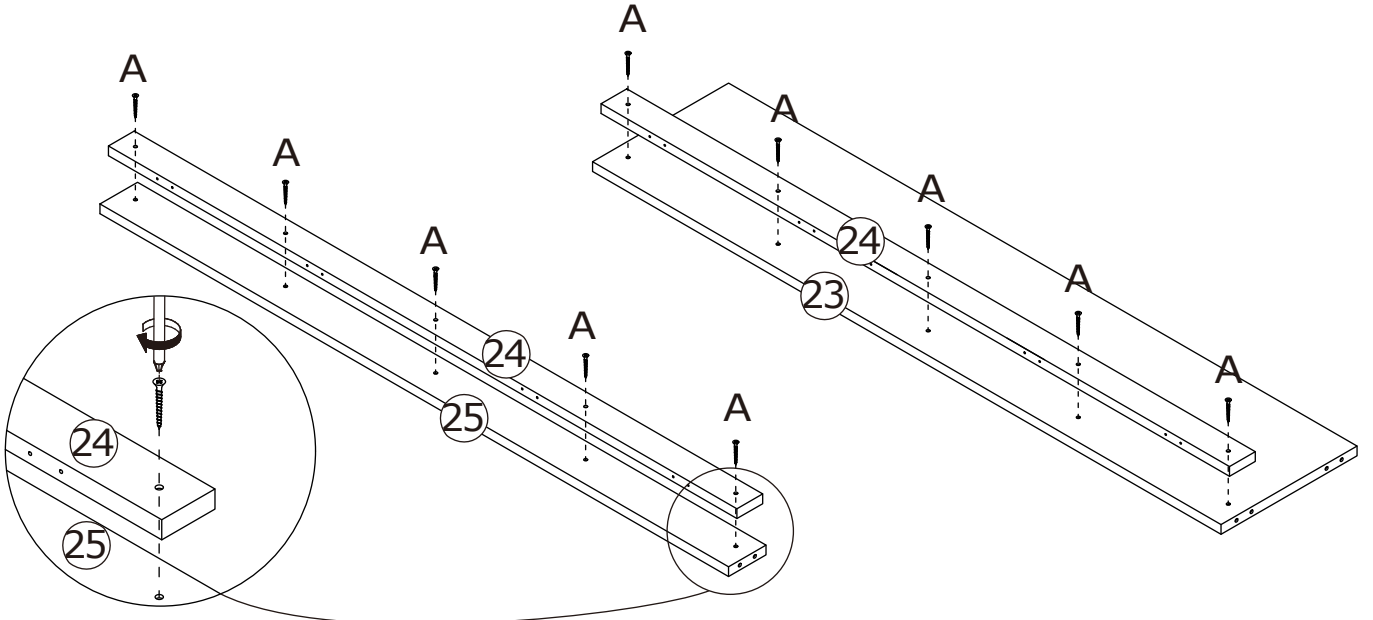
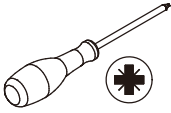
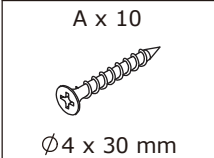

24

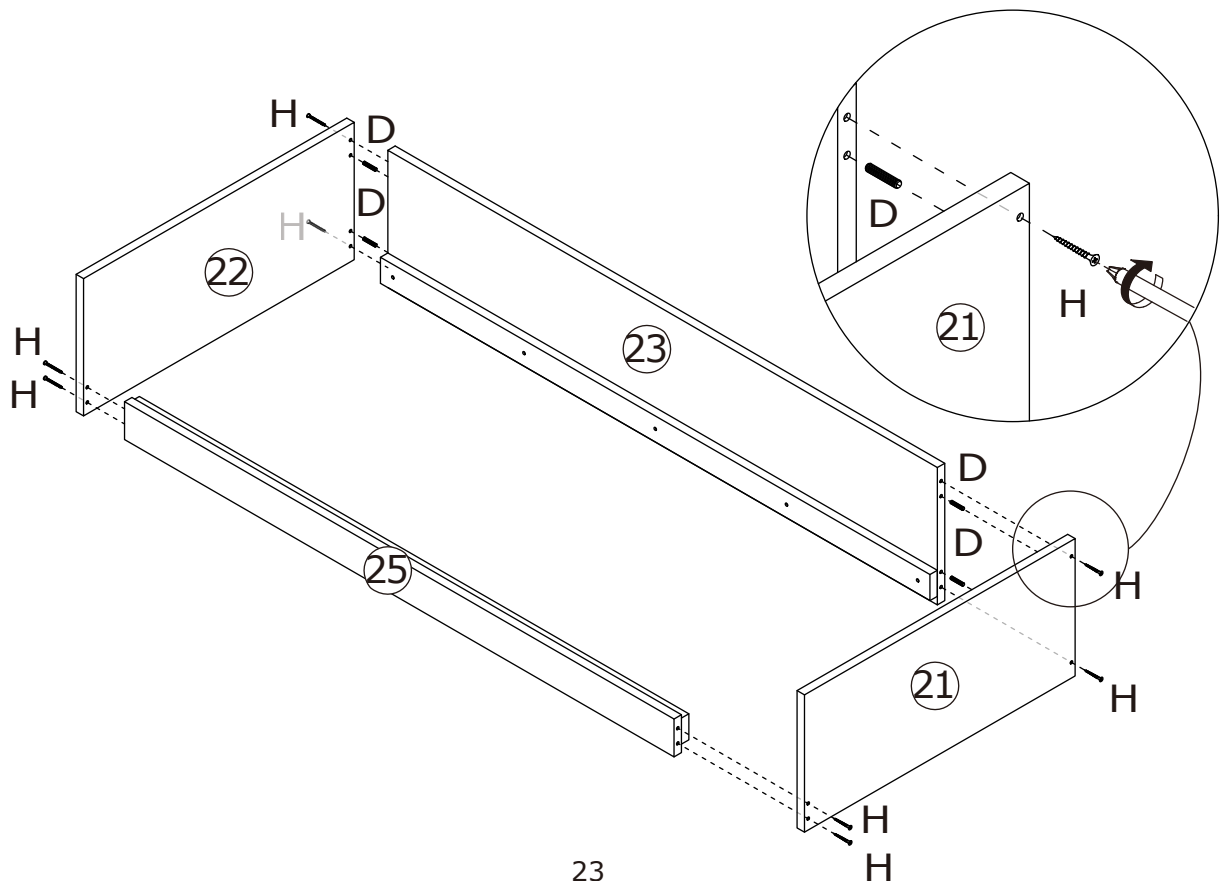
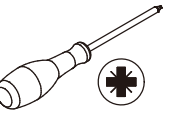
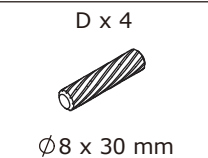
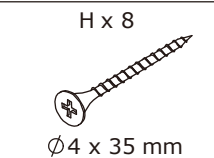

25

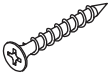
A x 16  
  
Ø4 x 30 mm

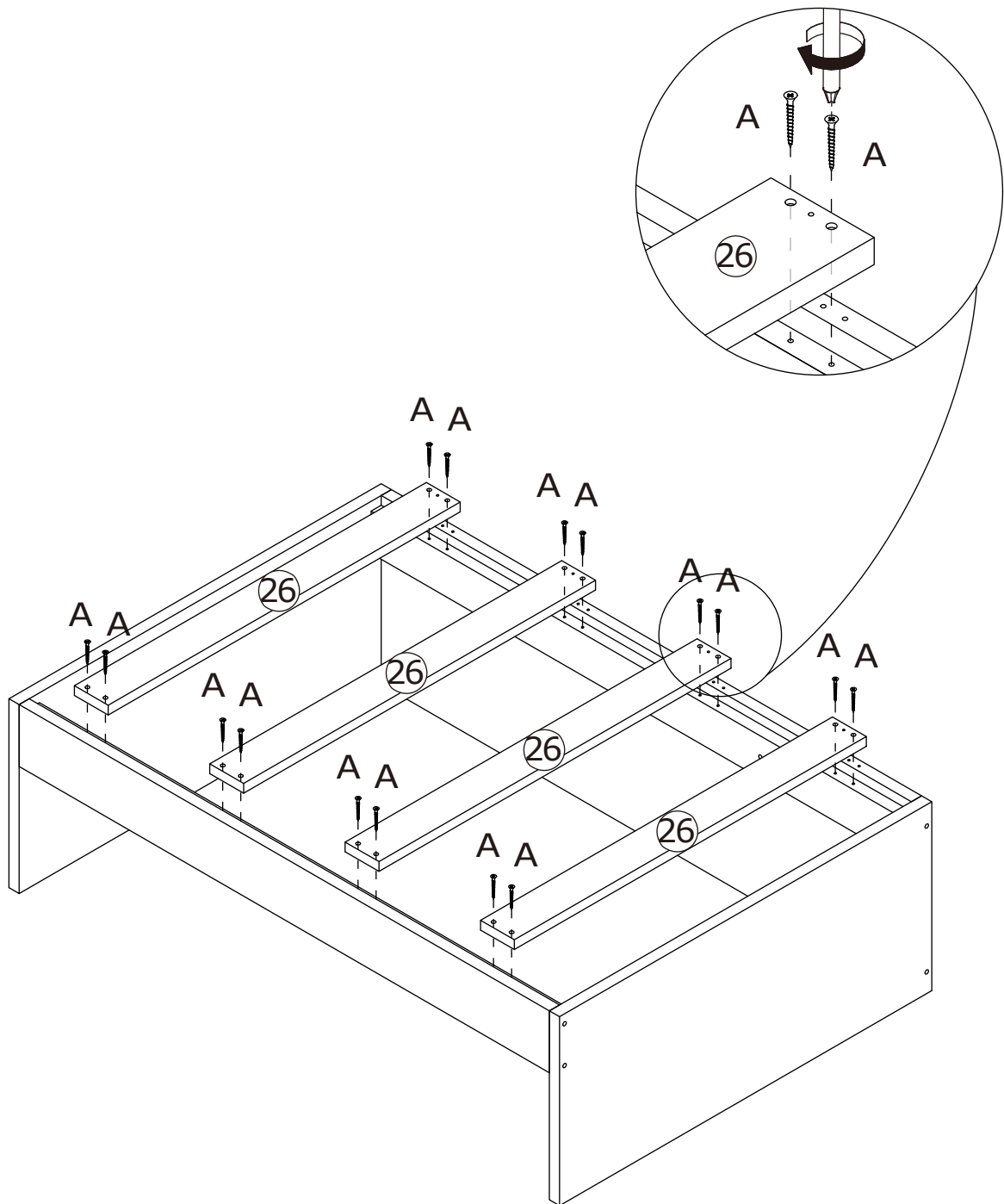
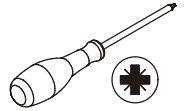

26

E x 24  
Ø 3.5 x 14 mm

G x 4

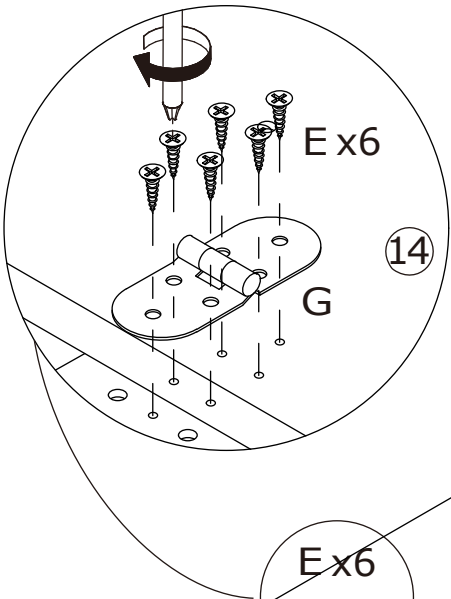
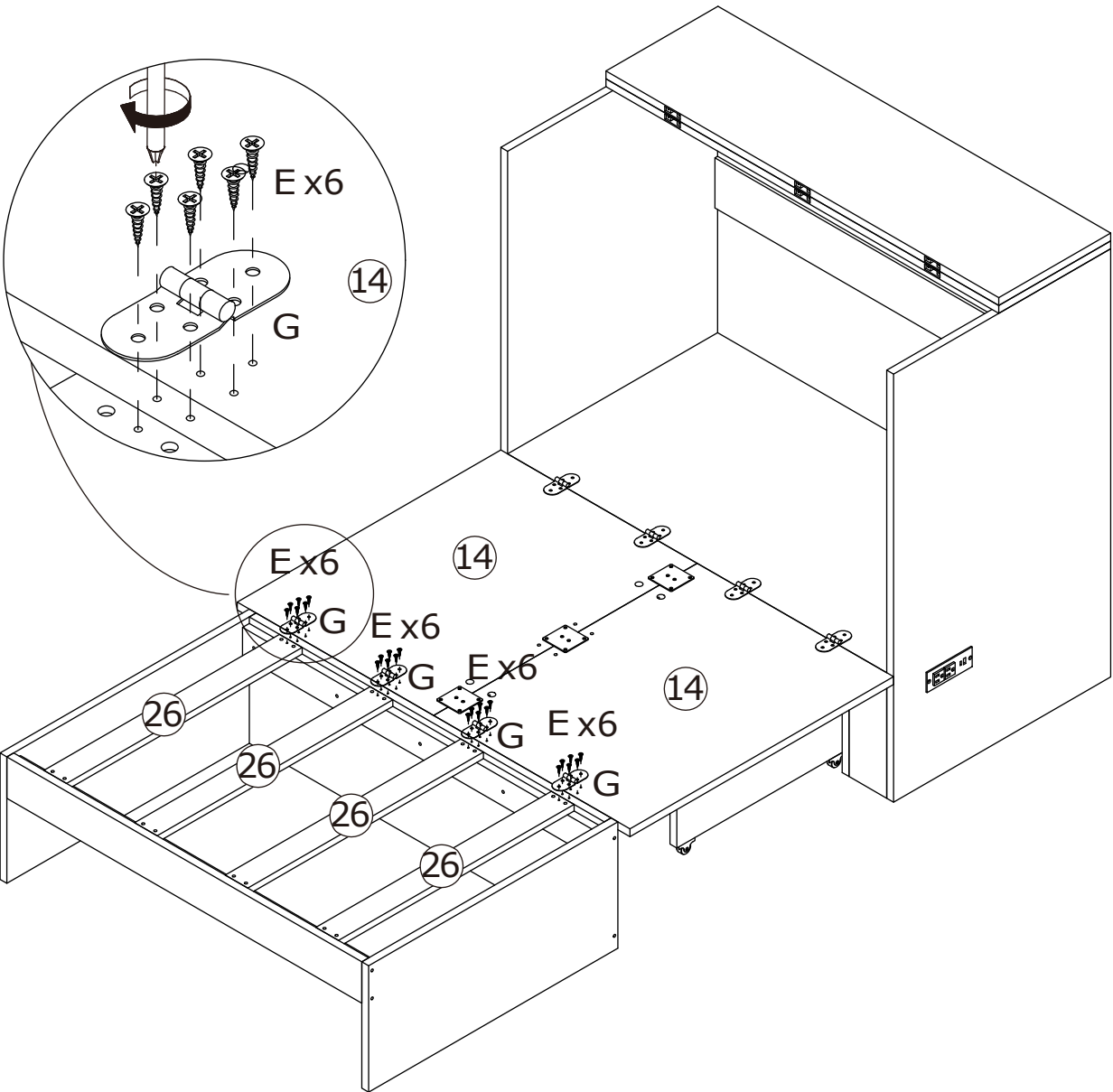

27

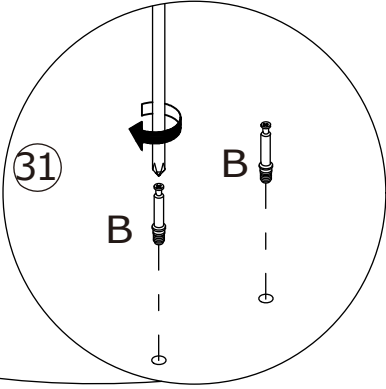
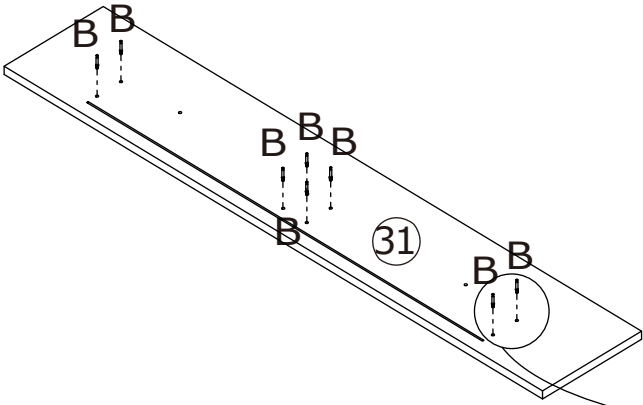
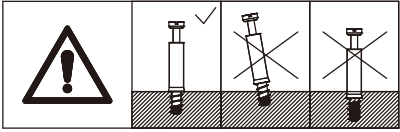
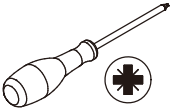
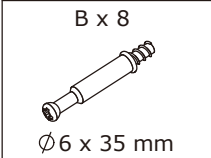

28

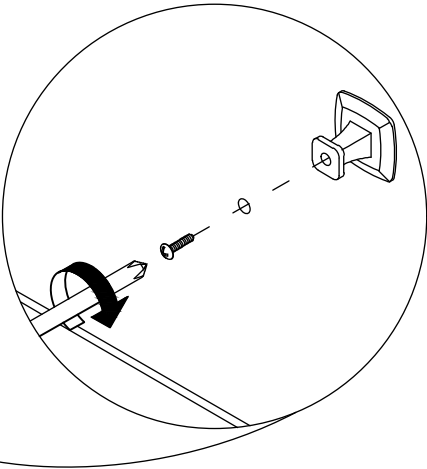
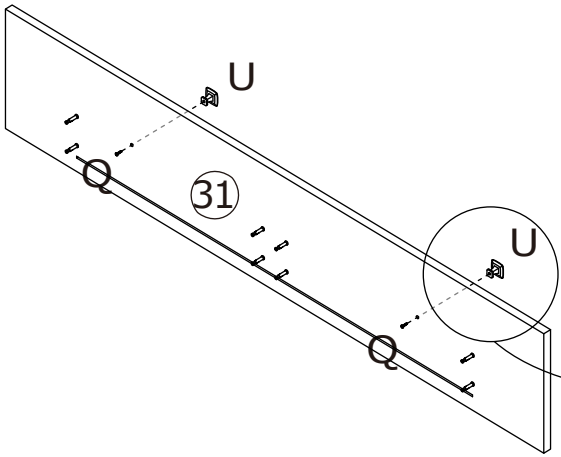
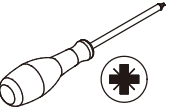
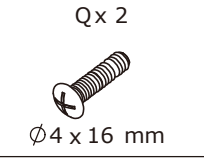
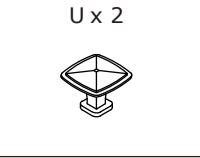

29

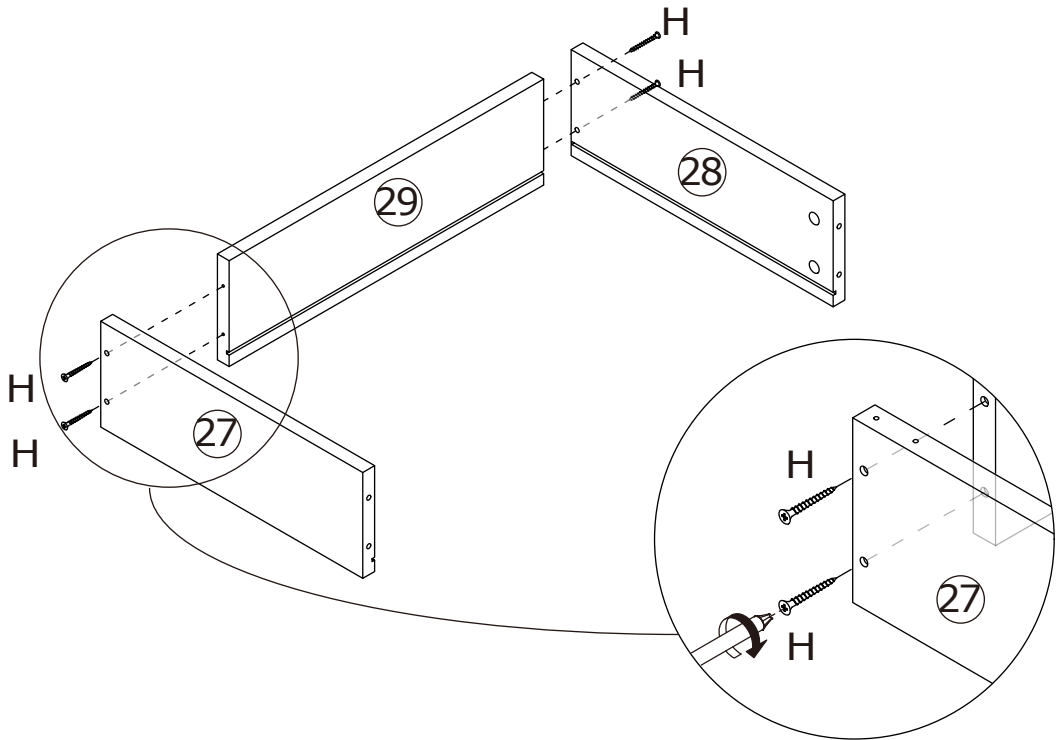
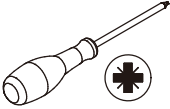
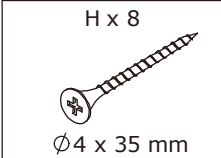

x2

30

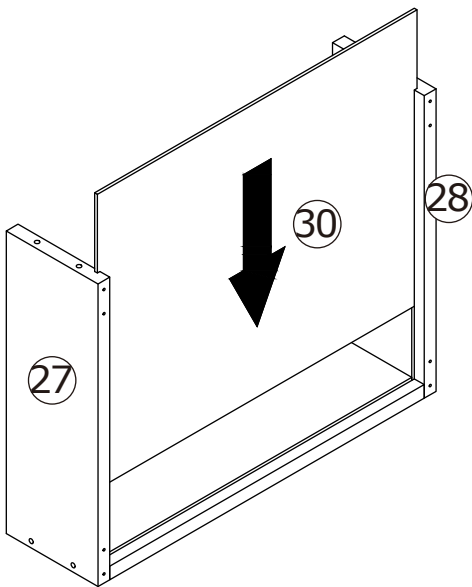

x2

31

C x 8  
Ø15 x 9 mm

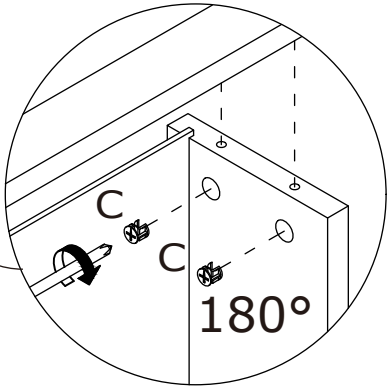
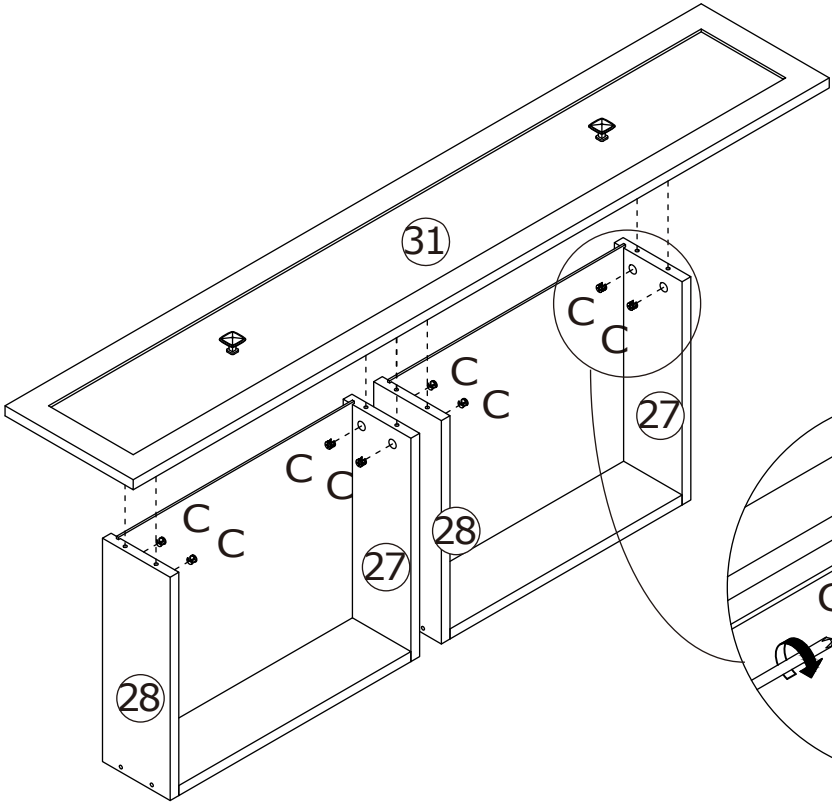
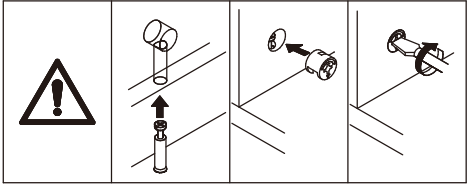
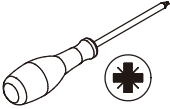

32

N x 16  
Ø4 x 14 mm

J x 8

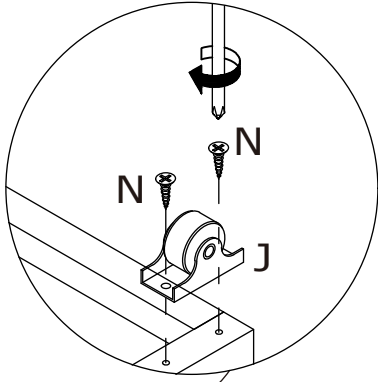
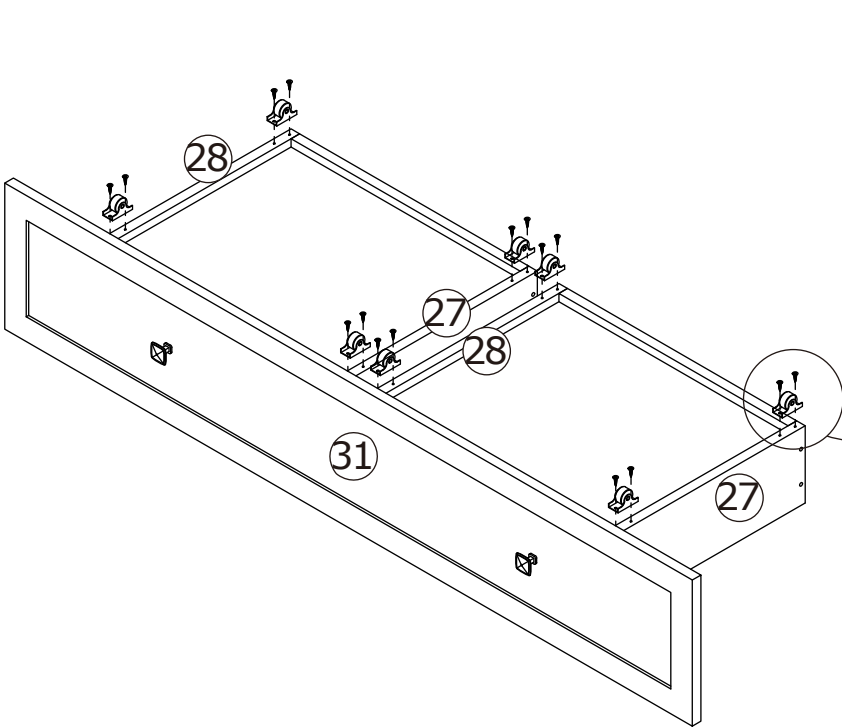
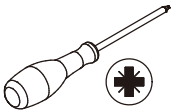

33

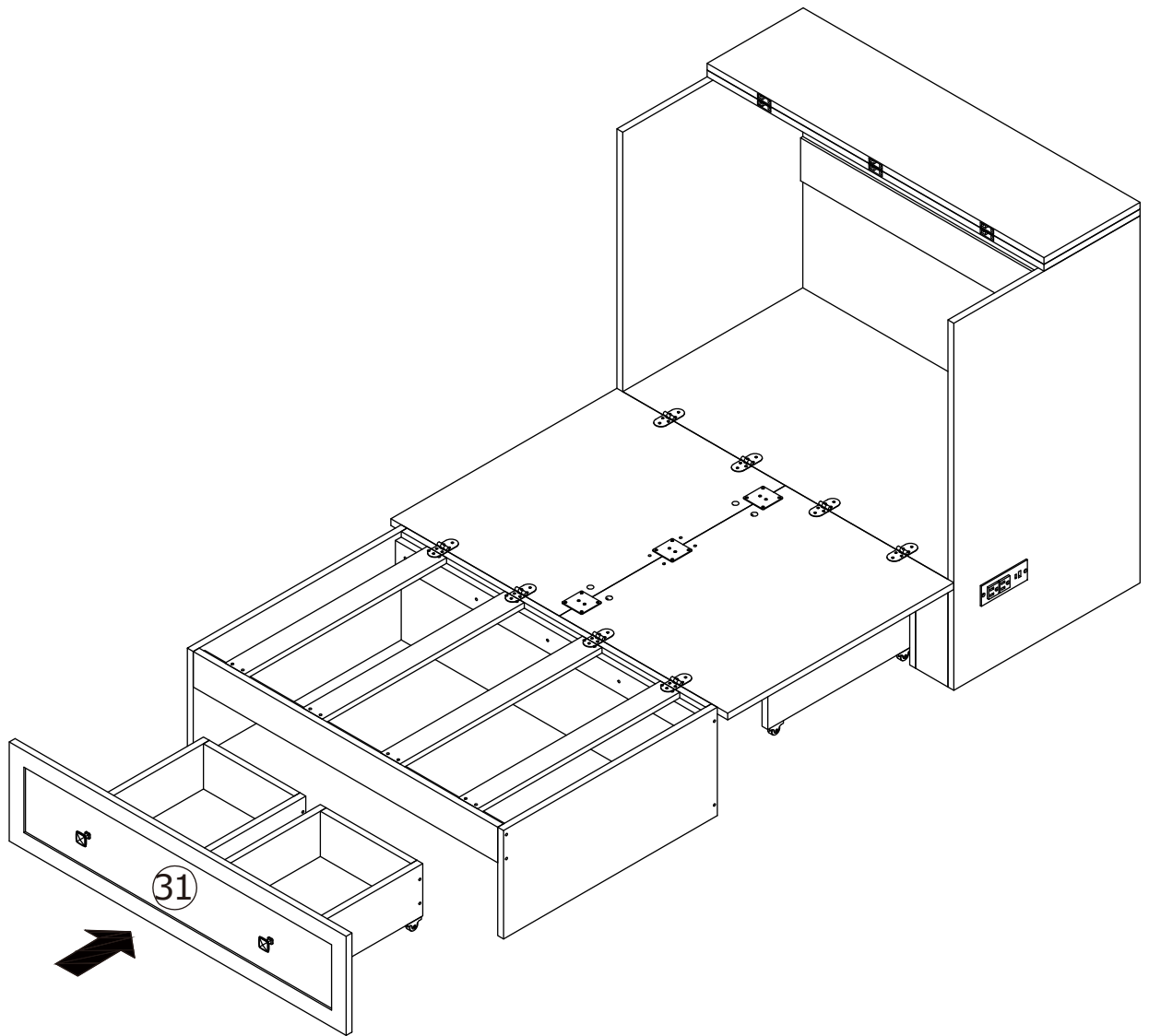

34

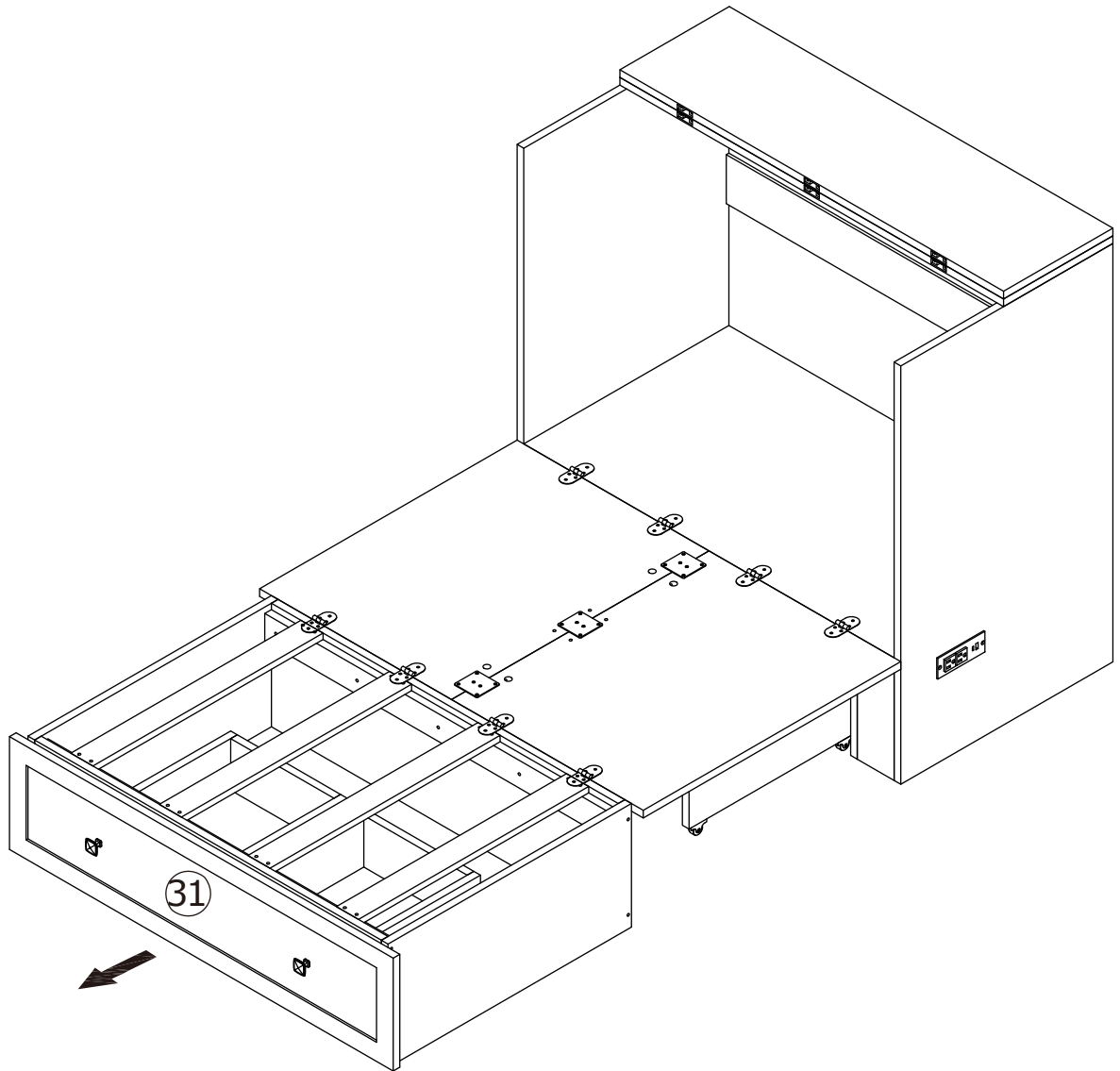

35

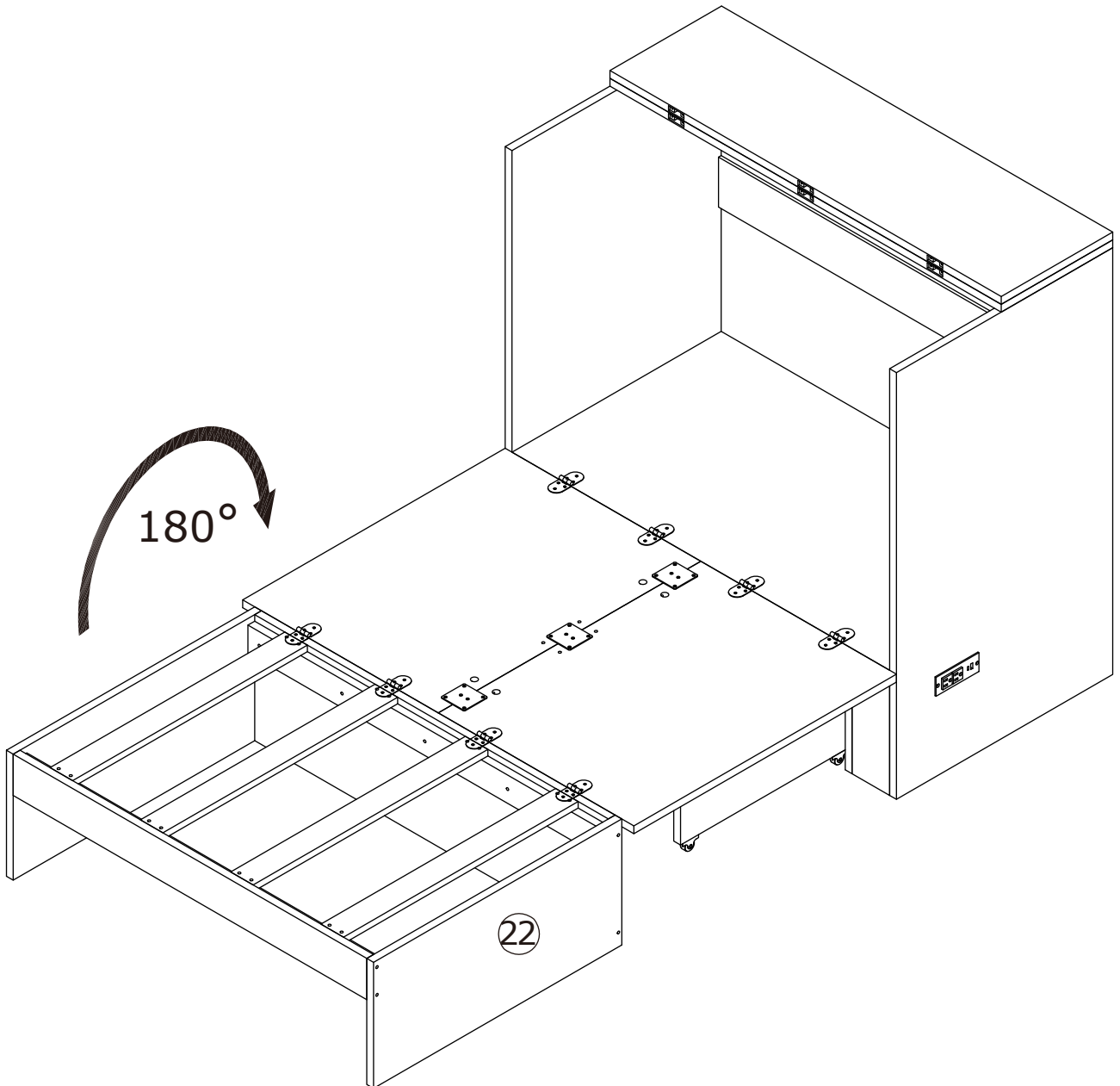

36

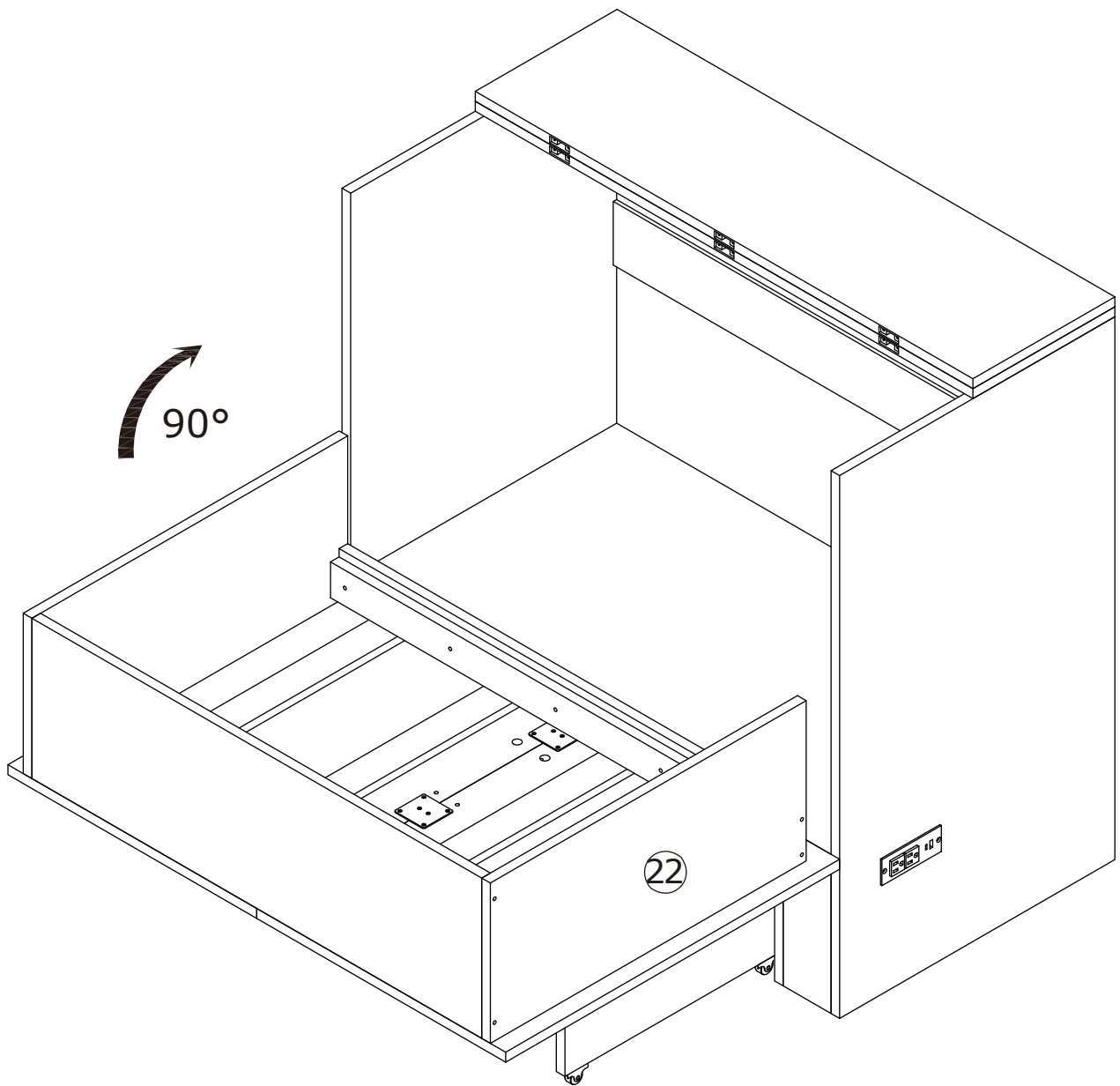

37

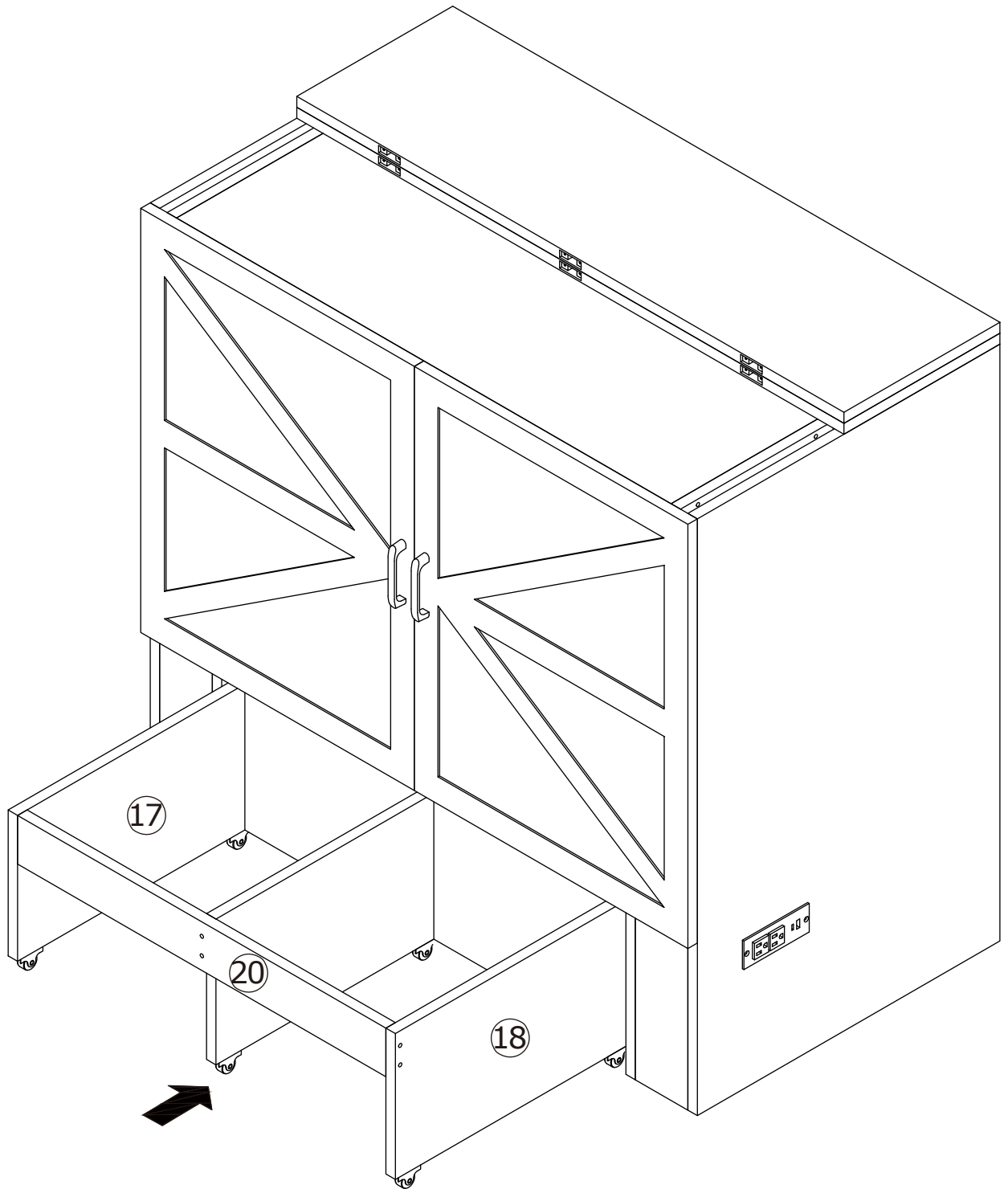

38

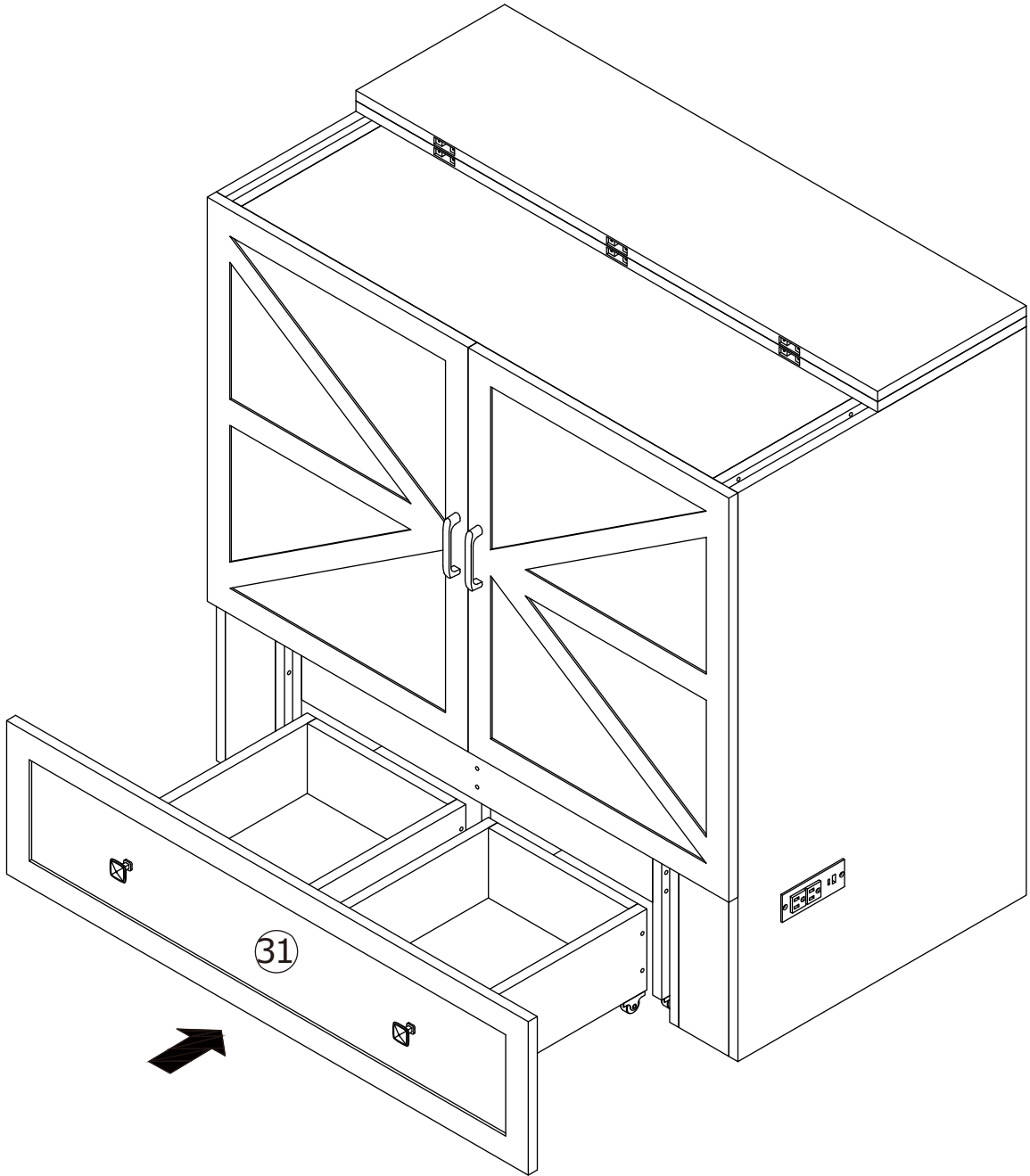

39

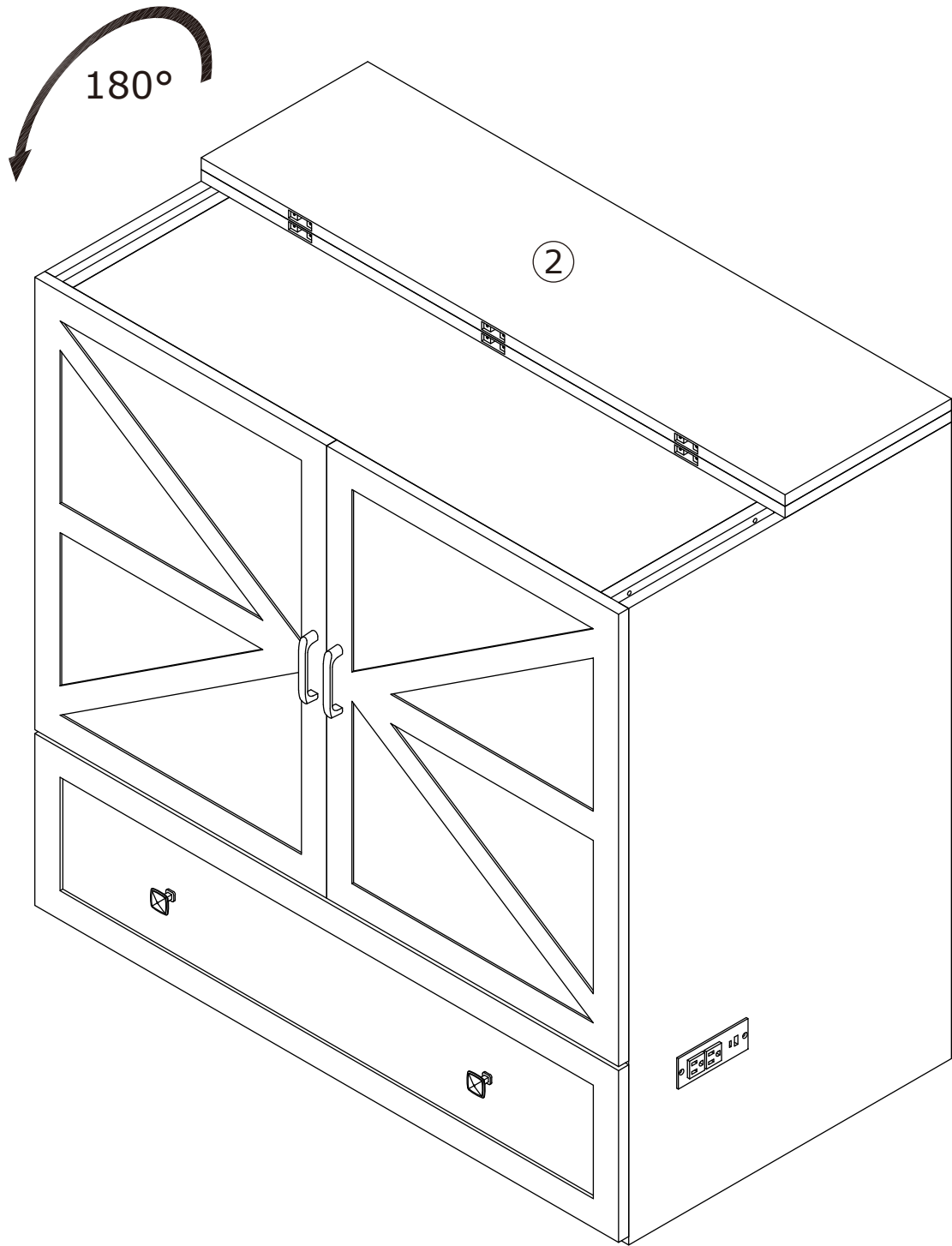

40

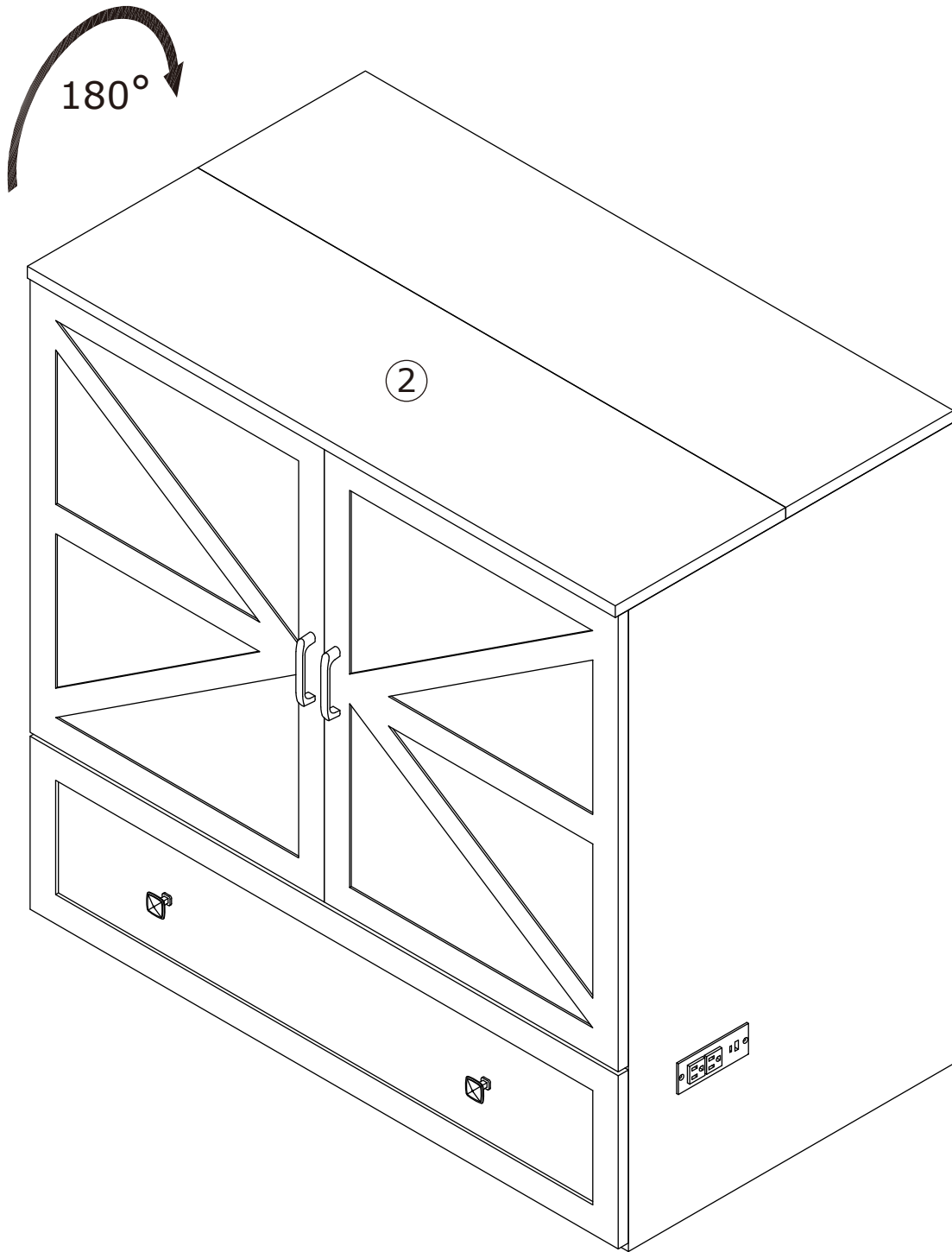

41

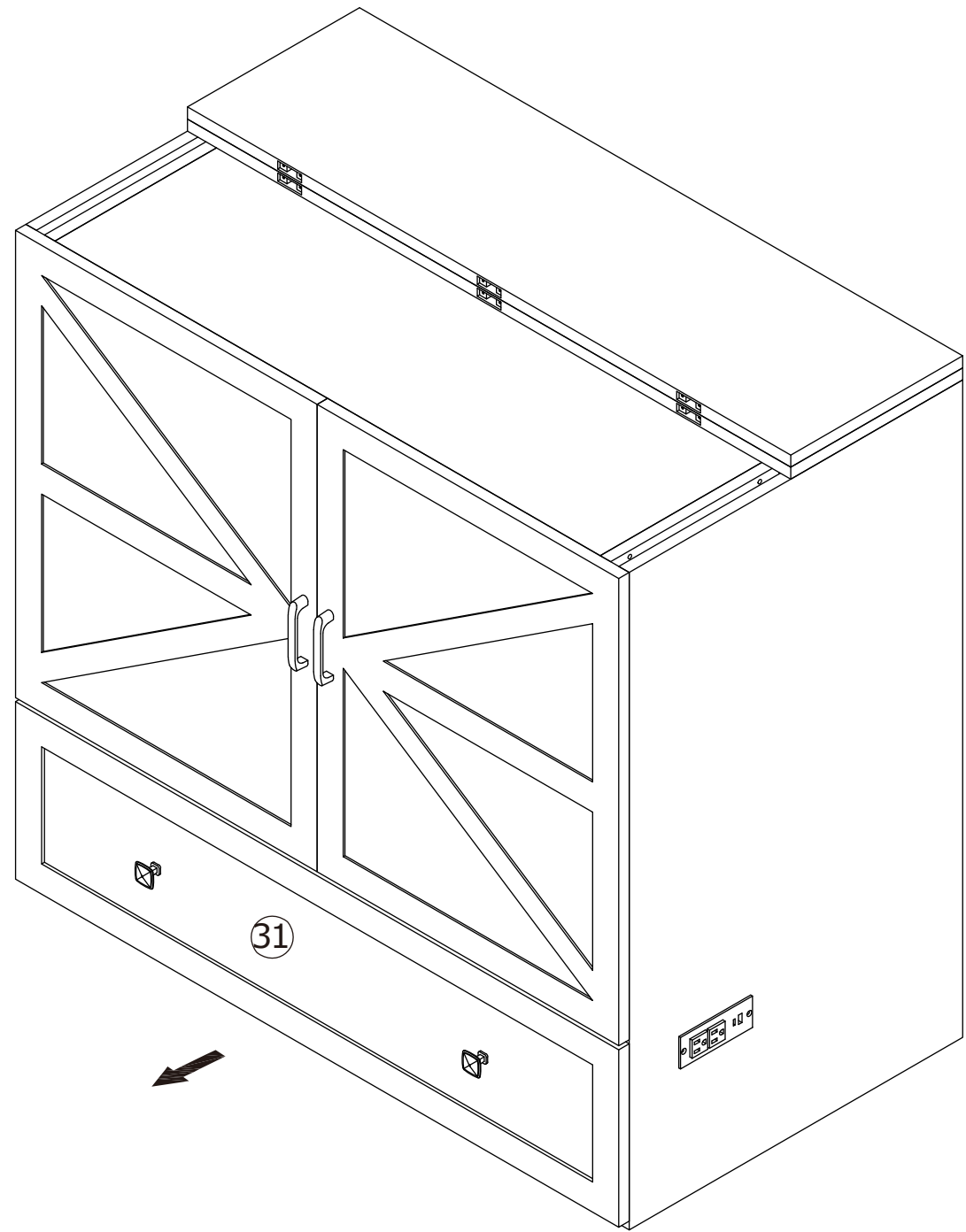

42

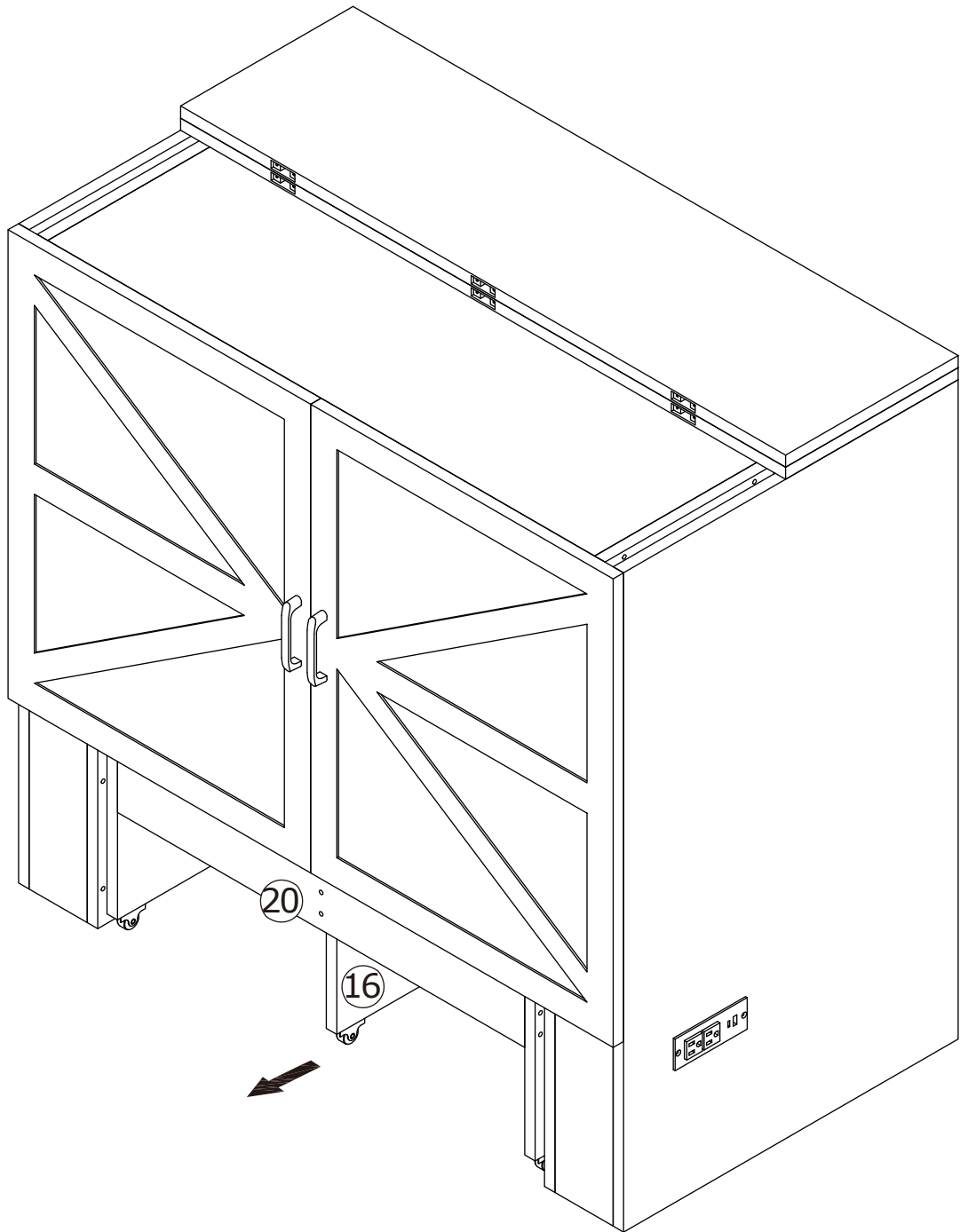

43

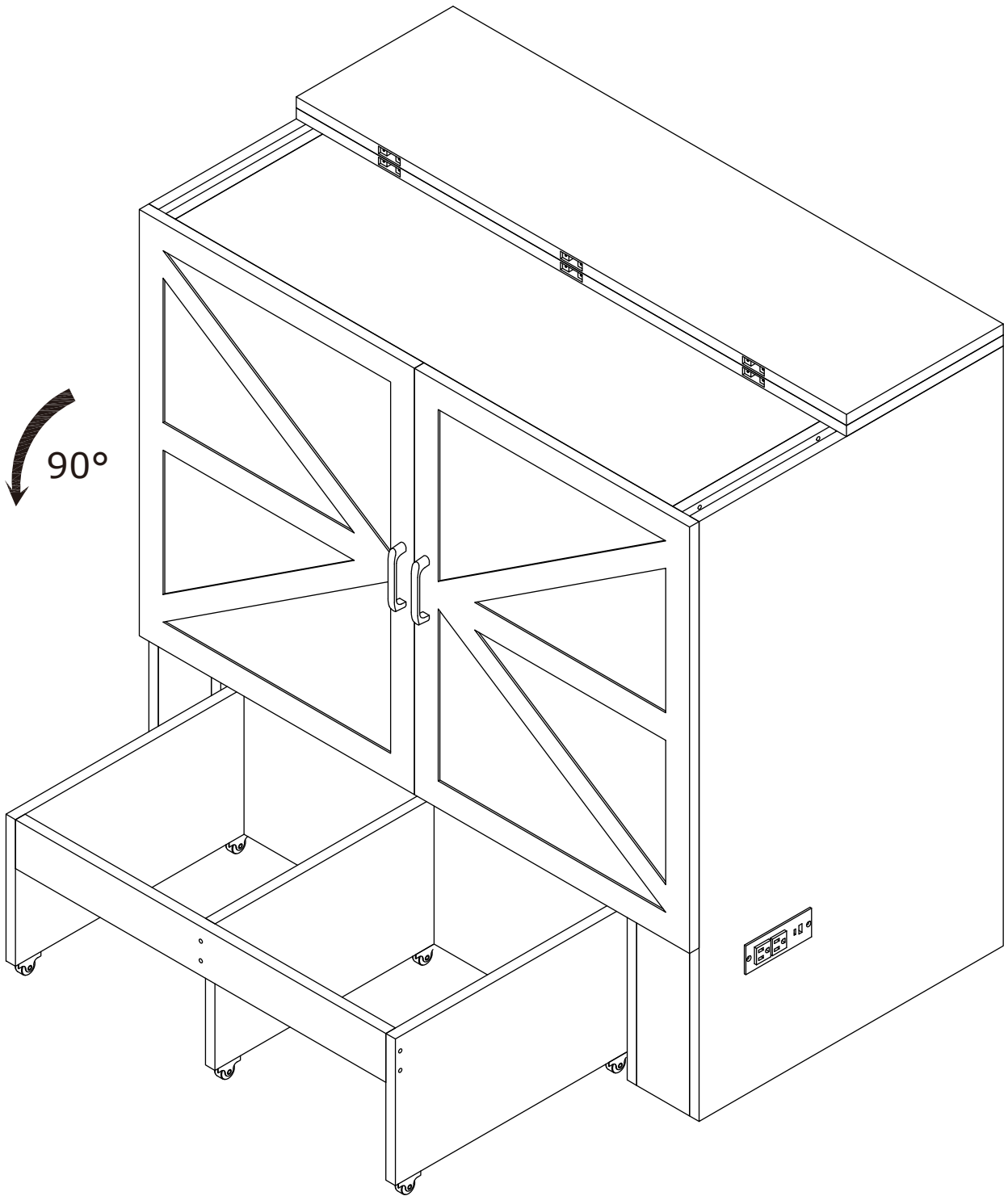

44

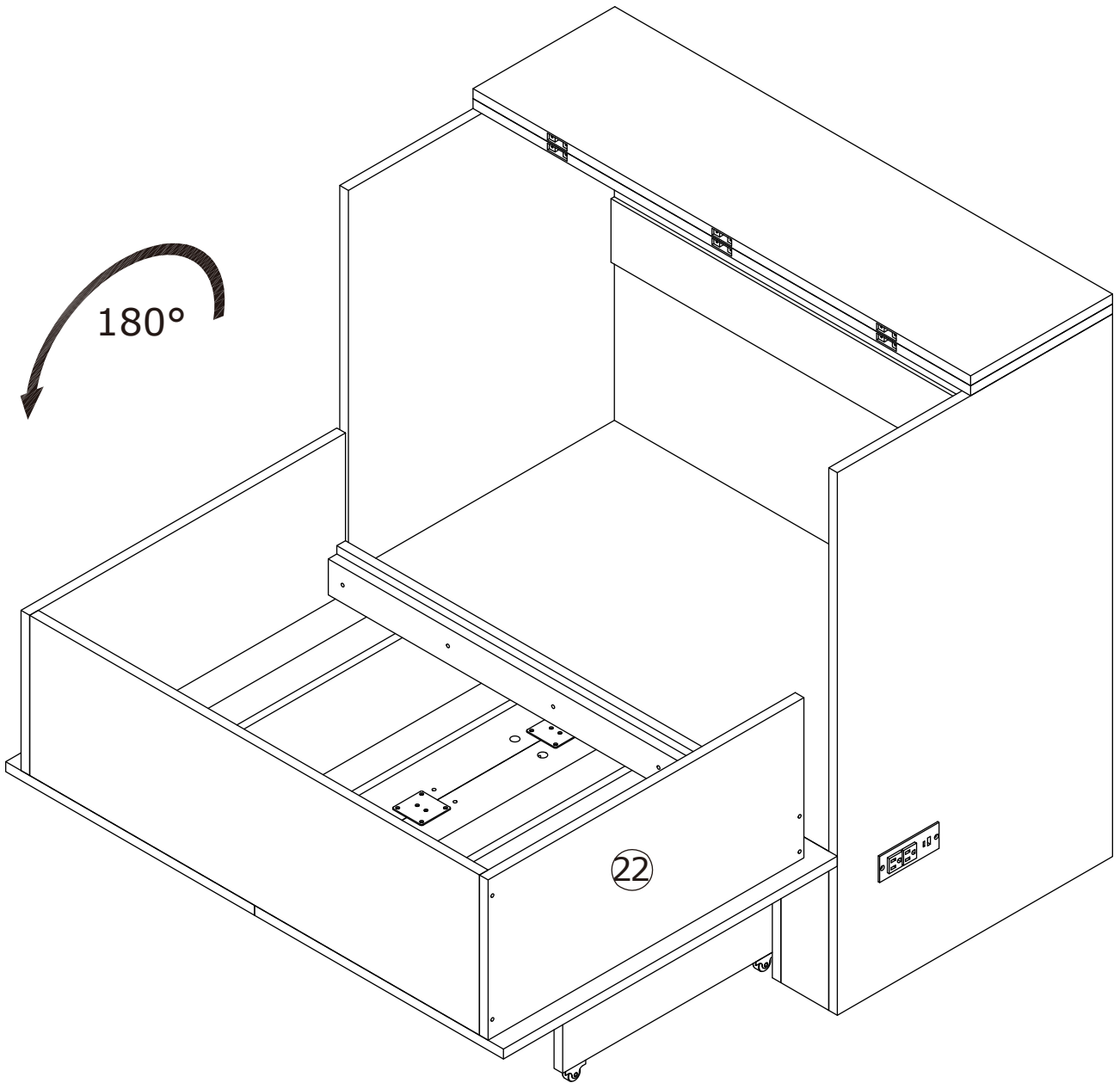

45

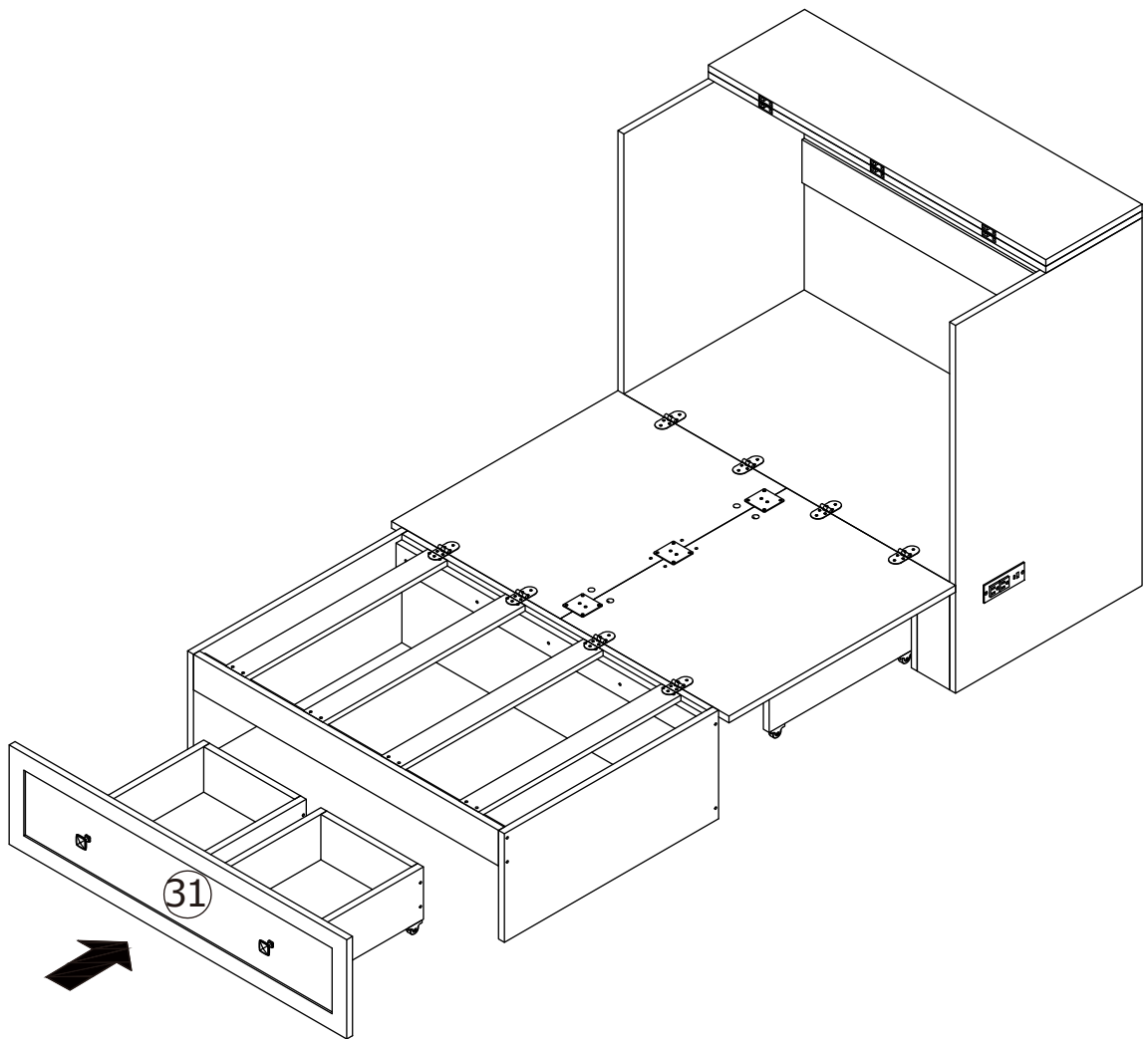

46



# Power supply

