

# ASSEMBLY INSTRUCTIONS COFFEE TABLE W/ STORAGE

## HARDWARE KIT

Ltr	Q'ty	Description	Size
A	1 pc	Allen wrench	4mm
B	8 pcs	Bolt	Ø1/4" * 2 1/8"
C	8 pcs	Lock washer	Ø1/4"
D	8 pcs	Flat washer	Ø1/4" * 3/4"
E	4 pcs	Screw	Ø8" * 1-1/2"
F	1 pc	Wrench	12mm
G	4 pcs	Flat washer	Ø5/16" * 3/4"
H	4 pcs	Caster	Ø2"

## Parts list

No.	Description	Q'ty
①	Leg	4 pcs
②	Shelf	1 pc
③	Storage Box	1 pc
④	Drawer	2 pcs
⑤	Knob/Screw	4 sets
⑥	Caster	4 pcs

### STEP 3 : ▼

Insert the shelf between the three legs. Add the fourth leg and secure with a bolt, lock washer and flat washer.

Secure the shelf to the legs using screws(E). Once the shelf is in place fully tighten all screws. Attached four casters (H) to the support wood block with flat washer (G) and wrench(F).

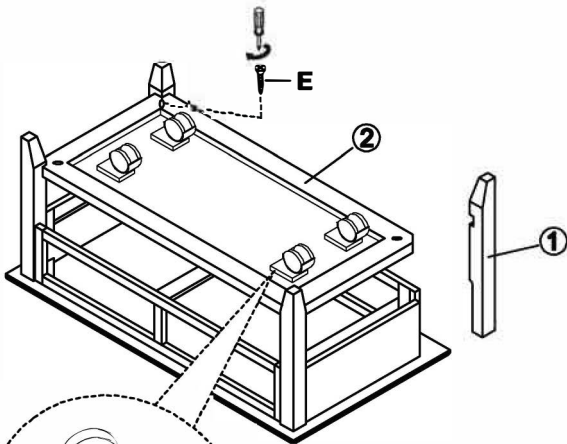

### STEP 1 : ▼

First pull out the drawer

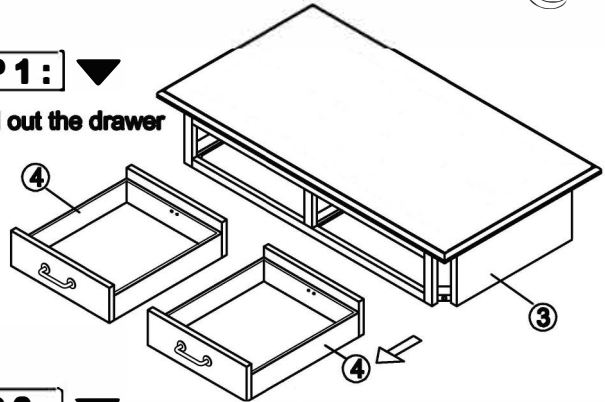

### STEP 2 : ▼

Carefully place the table top upside-down on a smooth, flat surface to prevent scratches during assembly. Attach three legs to the table top with Allen bolt (B), Lock washer (C) and Flat washer (D), loosely tightening with provided Allen wrench (A). Do not completely tighten bolts at this point.

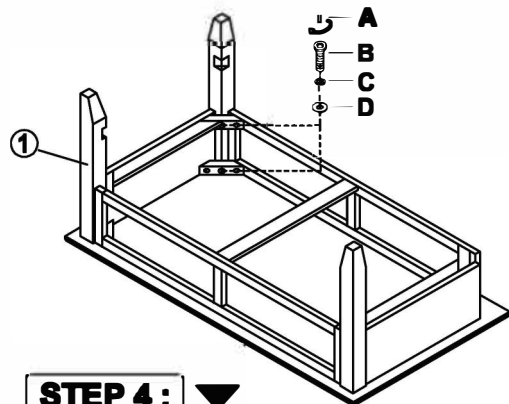

### STEP 4 : ▼

Carefully turn the assembled table the upright position. Put back the drawer. Assembly is now complete.

