

AIRMSSEN

COFFEE MAKER

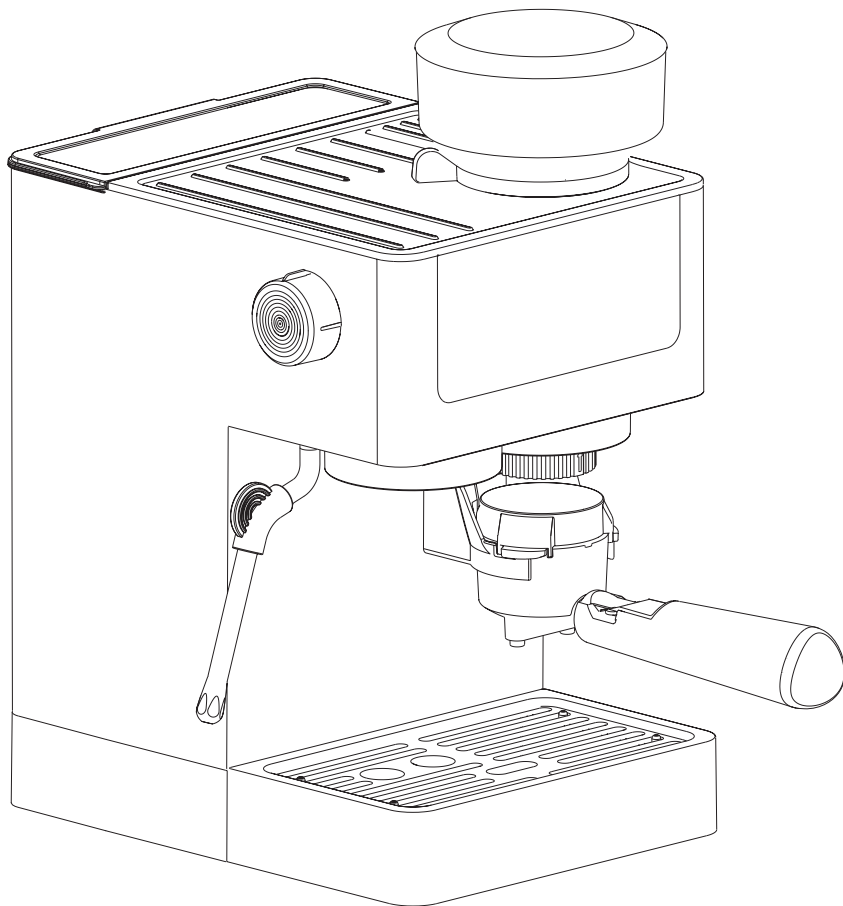

USER MANUAL

If you are having problems using this coffee maker..

Please email: support@airmsen.com

for assistance: www.airmsen.com

THANK YOU FOR MAKING AIRMSEN APPLIANCES A PART OF YOUR HOME.

CONSTANT INNOVATION FOR BETTER PRODUCTS

With “technology, innovation, health” as our core value, we strive to provide you with the preferred brand of household products in your healthy and quality life.

AIRMOSEN focuses on researching, developing and manufacturing various kinds of household supplies with advanced technologies and the idea of sustainable development. Aiming to promote the evolution of our lifestyle, we will bring our customers around the world a healthier, happier, more intelligent and ecofriendly home life with our high quality products.

SAFETY

Your safety and the safety of others is very important.

We have provided many important safety messages in this manual and on your appliance. Always read and obey all safety messages.



This is the safety alert symbol.

This symbol alerts you to potential hazards that can cause serious injury to you and others.

All safety messages will follow the safety alert symbol.

All safety messages will tell you what the potential hazard is, tell you how to reduce the chance of injury, and tell you what can happen if the instructions are not followed.

CONTENTS

IMPORTANT SAFEGUARDS	04
SAFETY INSTRUCTIONS	05
PRODUCT PARAMETERS	06
COMPONENT INTRODUCTION	07
CONTROL PANEL	08
PREPARATION BEFORE USE	09
OPERATION TIPS FOR BREWING COFFEE BEANS	10
OPERATION INSTRUCTIONS	11
CUSTOM PROGRAMMING SETTINGS	13
COFFEE MAKING	16
GRINDING	17
STEAM	18
CLEANING AND MAINTENANCE	19
CLEANING THE PORTAFILTER AND BREW HEAD	19
CLEANING THE STAINLESS STEEL STEAM WAND	19
GRINDER CLEANING	20
WATER TANK CLEANING	21
SELF-CLEANING	21
DRIP TRAY CLEANING	21
DESCALING	21
TROUBLESHOOTING	22
WARRANTY	25
CUSTOMER SUPPORT	26

IMPORTANT SAFEGUARDS

Congratulations on your purchase of the new Airmsen coffee machine. This user manual contains important information regarding the installation, use, and maintenance of this machine. Please spend some time reading this manual to make the best use of all functions of this coffee machine.

SAFETY INSTRUCTIONS

To reduce the risk of fire, electric shock, and/or personal injury, please always stick to the following basic safety precautions when using this machine::

1. Read all instructions
2. Ensure that your outlet voltage matches the voltage indicated on the label of the coffee machine.
3. To prevent fire, do not immerse the cord, plug, or machine in water or other liquids.
4. Close supervision is necessary when the machine is used by or near children.
5. Unplug the machine when it is not in use and before cleaning, and allow it to cool before attaching or removing parts.
6. Do not operate the machine if the power cord or plug is damaged, or if it malfunctions or is damaged in any way. Return the machine to an authorized service facility for examination, repair, or adjustment.
7. Using accessories not recommended by the machine manufacturer may result in fire, electric shock, or personal injury.
8. To disconnect the machine, turn all controls to the off position, then remove the plug from the wall outlet.
9. Do not touch hot surfaces.
10. Do not use the machine outdoors or for commercial purposes.
11. Do not let the power cord hang over the edge of a table or counter.
12. Use the machine only on a hard, flat, horizontal surface to avoid interrupting the airflow beneath the machine.
13. Before turning on the machine, ensure the water tank lid is tightly closed and filled to the minimum water level or above.
14. Do not remove the portafilter while brewing coffee. Ensure all three indicator lights are on before removing the portafilter to brew more coffee. Be cautious when removing the portafilter as the metal parts can be very hot. Make sure to hold the portafilter and use the filter clip to handle the coffee grounds.
15. Do not remove the water tank before turning off the machine.
16. This machine is not fit for operation via an external timer or separate remote control system.
17. Children must not play with this machine. Unless children are 18 years or older and under supervision, they must not perform cleaning and user maintenance.
18. Keep the machine and its power cord out of reach of children under 18 years old.
19. Before removing any spare or accessory parts, please first ensure that the three indicator lights are on, then press the power button to the off position "0", and finally unplug the machine.

20. Do not remove the portafilter during the brewing process.
21. Please be very careful when removing the portafilter, as the metal parts may still be very hot, and additionally, hot water may be floating on top of the filter. Hold the portafilter only and use the filter clamp to handle the brewed coffee grounds.
22. If the coffee is not dripping, it indicates that the filter is clogged. Turn off the machine and let it cool down. The clog may be caused by coffee that is ground too finely. Refer to the "Problems and Causes" section.
23. Do not place it on or near a hot gas or electric stove, or in a heated oven.
24. This machine is designed for family use or other similar applications, such as:
 - Staff kitchen areas in shops, offices, and other working environments;
 - Farmhouses; clients in hotels, motels, and other residential environments;
 - Bed and breakfast environments.
25. Save these instructions

NOTE:

- When using the Espresso/Americano function, do not remove the water tank or portafilter to prevent burns or machine damage. Ensure the machine is in standby mode, with all buttons lit and in a stable condition, before removing the portafilter. To add water, please first press the off button on the side of the machine.
- When using Steam, do not touch the pipes and steam with your hands to avoid burns.

SAFETY INSTRUCTIONS



Before using the appliance, check it for any externally visible damage. Under no circumstances should you use a damaged appliance. A damaged appliance could be dangerous.



The electrical safety of this appliance can only be guaranteed when continuity is complete between it and an effective grounding system. It is most important that this basic safety requirement is present and regularly tested and where there is any doubt the electrical system in the house should be checked by a qualified electrician.

The manufacturer cannot be held liable for the consequences of an inadequate grounding system (e.g. electric shock).



Do not connect the appliance to the mains electricity supply by a multi-socket unit or an extension lead. These do not guarantee the required safety of the appliance (e.g. danger of overheating).



This appliance may only be installed in mobile installations such as ships if a risk assessment of the installation has been carried out by a suitably qualified engineer.



Faulty components must only be replaced by original spare parts. Only when these parts are fitted can the safety of the appliance can be guaranteed.



Always disconnect the coffee make from the electrical supply for maintenance work (switch off at the wall socket and remove the plug).



If the connection cable is damaged it must be replaced with a special cable, available from the manufacturer. For safety reasons, this must only be fitted by the service department or an authorised service technician.

ABOUT ELECTRICITY CONNECTING



CAUTION, for personal safety:

DO NOT USE AN EXTENSION CORD OR AN ADAPTER PLUG WITH THIS APPLIANCE. DO NOT, UNDER ANY CIRCUMSTANCES, CUT OR REMOVE THE THIRD GROUNDING PRONG FROM THE POWER CORD.

Electrical requirements

- An 220-240 V, 50/60 Hz fuse or a circuit breaker.
- An individual branch circuit serving your coffee make.
- Use a power outlet with a maximum allowable current of 16 A. (The maximum current for this coffee make is 6.5A.)



In the event of a fault or for cleaning purposes, the appliance is only completely isolated from the electricity supply when:

- it is switched off at the wall socket and the plug is withdrawn, or
- it is switched off at the mains, or
- the mains fuse is disconnected, or
- the screw-out fuse is removed (in countries where this is applicable).



Do not make any alterations to the appliance, unless authorised to do so by the manufacturer.



Never open the casing/housing of the appliance.

Tempering with electrical connections or components and mechanical parts is highly dangerous and can cause operational faults or electric shock.



While the appliance is under guarantee, repairs should only be undertaken by a service technician authorised by the manufacturer. Otherwise the guarantee will be invalidated.

PRODUCT PARAMETERS

Power Voltage	Power	Water Tank Capacity
220-240V, 50/60Hz	1350W	60.87Oz / 1.8L

COMPONENT INTRODUCTION

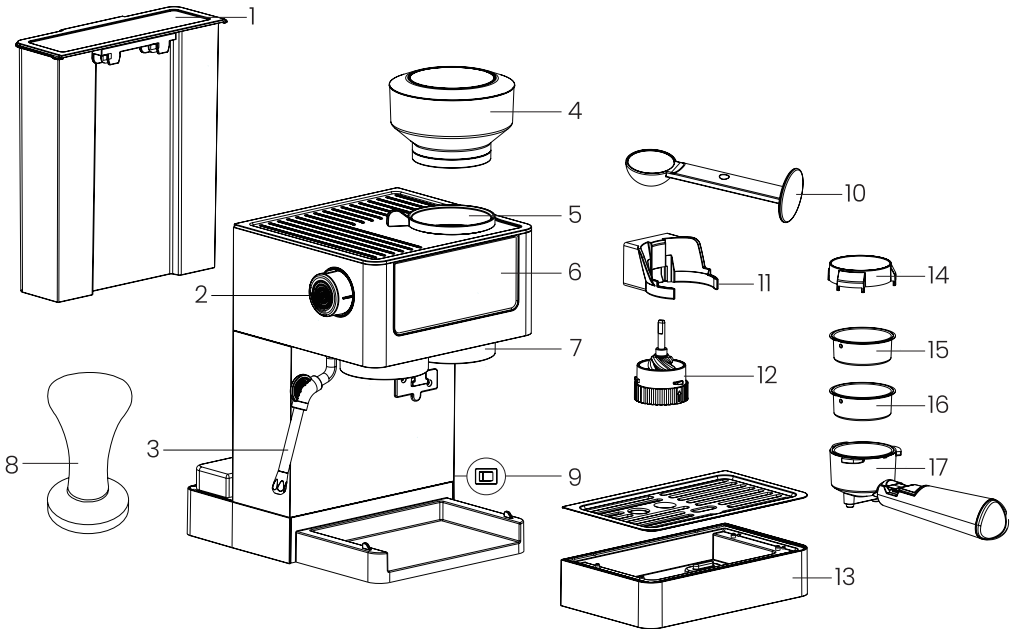

1. 60.87 oz (1.8L) Removable Water Tank
2. Steam Knob
3. Stainless Steel Steam Pipe
4. Removable Bean Hopper
5. Grind Size Adjustment Knob
6. Control Panel
7. Coffee Grounds Outlet
8. Coffee Tamper
9. Machine Switch
10. Coffee Measuring Scoop and Tamper

11. Removable Grinding Bracket
12. Removable Grinding Conical Burr
13. Removable Drip Tray
14. Dosing Collar
15. Double Shot Filter Basket
16. Single Shot Filter Basket
17. Portafilter Holder



CONTROL PANEL



	Espresso	Espresso Cool	Americano	Grinding
Single	35-50ml (1.18-1.69oz)	120-150ml (4.06-5.07oz)	150-180ml (5.07-6.09oz)	10-12g (0.33-0.34oz)
Pair	80-100ml (2.71-3.38oz)			22-24g (0.7-0.8oz)

1. When the power button is turned on, the machine will beep and enter the standby mode. All buttons of available functions on the display will light up.

Note: In the standby mode, the machine will not automatically start preheating.

2. When you select the coffee "", only this "" will remain on and will flash for the remainder of the preheating time.

Note: Do not press the button again, otherwise your selection will be canceled.

3. When preheating is completed and coffee brewing begins, the selected coffee function will remain lit, and the machine will beep three times after the brewing cycle is completed; all function icons will light up, and the machine will return to the standby mode.
4. In case of inactivity for five minutes, the machine will enter the sleep mode. All lights will be turned off. When you tap any function key on the screen, the screen will light up and enter the standby mode.

PREPARATION BEFORE USE

NOTE:

- After placing the machine on the workbench, leave at least 1.18in. / 3cm of space from the machine surface to the side wall or back wall, and at least 5.91in. / 15cm of space above the coffee machine, as the machine will turn to be very hot.
- Wash all accessories with warm water and detergent.
- **After receiving the product, press the Espresso Cool button “” to drain any residual water from the machine’s pipes.**
- For periods of inactivity exceeding 3–4 days, perform an internal rinse cycle prior to initial beverage preparation.

Before brewing coffee:

1. Ensure the steam knob (left side of machine) is fully closed.

- Rotate it to the “O” (OFF) position

If left open:

- The “**Steam**” indicator will flash continuously.
- Water will discharge from the steam pipe instead of brewing coffee.



2. To resolve flashing “**Steam**” warning:

- Turn steam knob clockwise until firmly closed at “O”.
- The indicator will stop flashing, enabling normal coffee function.

Pre-Use Rinsing (Required Before First Use & After Long Inactivity).

- Always rinse the internal circuit before use (especially if unused for 3+ days).

Initial Setup & Power On.

1. Plug into a power outlet and press the **ON/OFF** switch.
2. Place a cup (minimum 3.38Oz / 100 mL capacity) under the hot water nozzle.
3. Press the “**Espresso Cool** ” button to drain any residual water from the machine’s pipes.
4. Once brewing finishes, press the “**Steam** ” button to release steam for a few seconds, then rinse the steam circuit.
5. For optimal performance, repeat this process 3–4 times to clear residual water from the steam system.
6. The machine is now ready for normal use.

OPERATION TIPS FOR BREWING COFFEE BEANS

1. Place the coffee beans into the bean hopper. It is better to grind only the amount of coffee beans needed for immediate use to ensure the coffee will always be freshly brewed.
2. Align the unlock “☐” button on the bean hopper with the triangle “▲” button on the machine, then slowly rotate it to the left until it reaches the lock “☒” button.
3. The default grind setting is 5-7 (medium grind). If the coffee is ground to be too fine or too coarse, adjust the grinding level to satisfy your personal taste and fit the type of coffee used.

Note: There are numbered settings on the grind fineness selector. The smaller the number, the finer the coffee grind. The larger the number, the coarser the coffee ground. It is recommended you start with setting 5 and adjust it as needed.

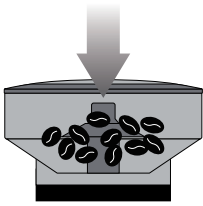

1

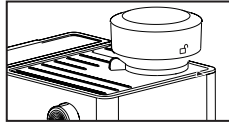

2



3

Please note:

- Different varieties of coffee beans will produce different grinding effects, so the initial adjustment of the dose requires special care.
 - For most coffees, a grind level is recommended between 3 and 6.
 - Selecting 1 or 2 for very fine grinding. It is only used for very special coffees (light roast) or when you notice poor coffee brewing quality due to burr wear (too coarse grinding).
4. Place the dosing collar on the filter holder.

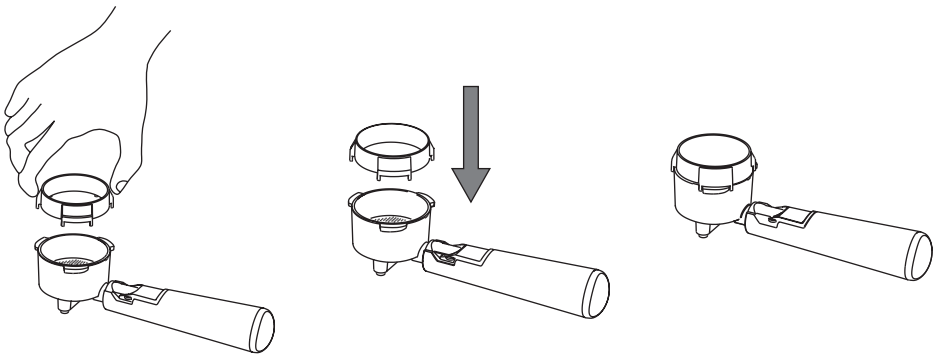

5. Place the filter holder on the grinding bracket.

6. Touch the grinding button “☪” to select 1 cup or 2 cups, the machine starts working and stops automatically after grinding is completed.

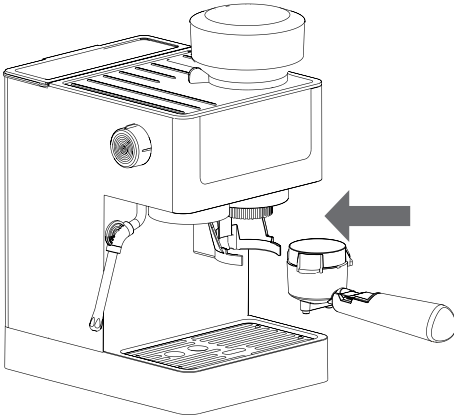

5

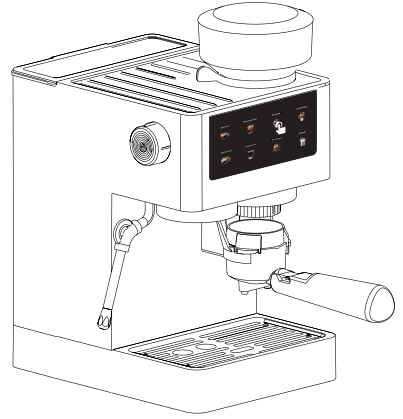

6

OPERATION INSTRUCTIONS

1. To fill the Water Tank

1. Use a container to fill it in place, or remove it and fill under a tap.

NOTE: It is recommended to fill the water tank with soft or purified water only. Do not use warm or hot water.

2. Keep water level between **MIN** and **MAX** marks.
3. Close the Water Tank lid securely and reinsert it into the unit, ensuring a tight fit.

2. Preparing the Filter

1. Select the appropriate filter.

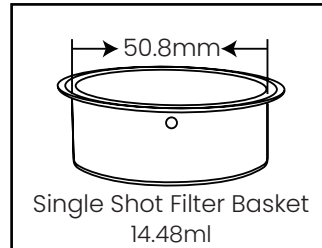
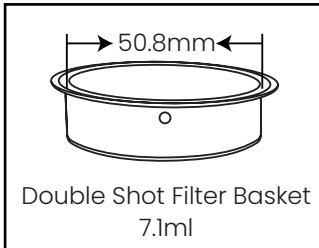

3. Filter Setup

1. Install the selected filter into the funnel handle.

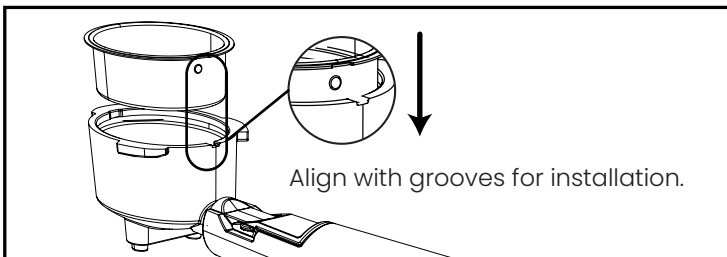

4. Coffee Grounds Preparation Guide

1. Using the spoon, fill the filter with freshly ground coffee.
2. Remove any excess coffee from the edges of the filter.
3. Use the Powder Pressing Hammer to evenly compress the coffee grounds.

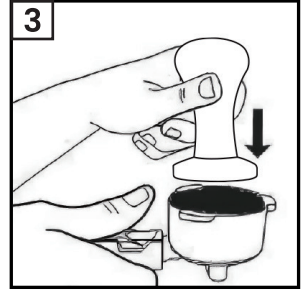
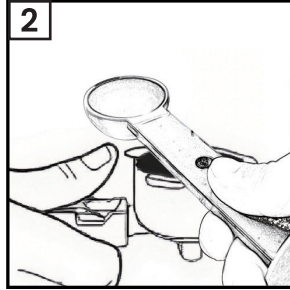
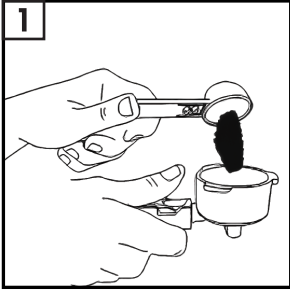

5. Installing the funnel handle

1. Place the funnel handle beneath the brew head.
2. Match the funnel handle with the "UNLOCK" (🔓) symbol on the machine.
3. Gently rotate right until aligned with the "LOCK" (🔒) symbol.

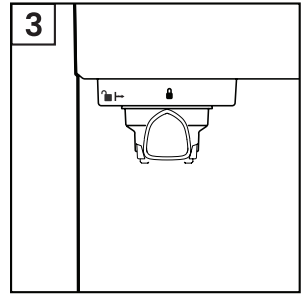
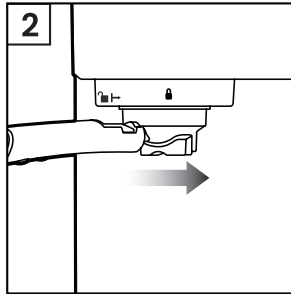
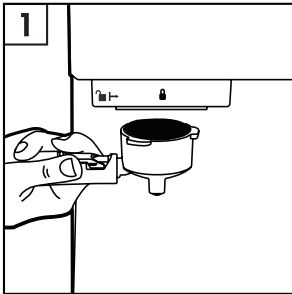

6. Make sure unit is plugged in.
7. Turn the unit right side switch on.
8. Start up the coffee maker.

⚠️ WARNING



To prevent burns from hot steam/water and avoid damage to the machine:

1. Never remove the water tank or funnel handle during coffee brewing or milk frothing.
2. Ensure the machine is in standby mode before removing the funnel handle for refills.
3. Always power off the machine (press the right side on/off switch button until all icons on the LED display turn off) before refilling water.

CUSTOM PROGRAMMING SETTINGS

ESPRESSO

1. Enter Adjustment Mode



- Simultaneously press “**Espresso**  + **Steam** ” buttons to enter coffee volume adjustment mode.
- **Note: Adjustable range for Espresso is 6s (min) – 30s (max).**

2. Confirm Settings

- Press the **Espresso button again** to confirm adjustment.
- The buzzer will sound three beeps (“beep-beep-beep”) to confirm successful setting.



3. Factory Reset

In standby mode:

- Press and hold “**Steam**  + **Customized** ” buttons simultaneously.
- All custom settings will revert to factory defaults.
- Five consecutive buzzer beeps.

ESPRESSO X2

1. Enter Adjustment Mode



- Simultaneously press “**Espresso x2**  + **Steam** ” buttons to enter coffee volume adjustment mode.
- **Note: Adjustable range for Espresso x2 is 12s (min) – 50s (max).**

2. Confirm Settings

- Press the **Espresso x2 button again** to confirm adjustment.
- The buzzer will sound three beeps (“beep-beep-beep”) to confirm successful setting.



3. Factory Reset

In standby mode:

- Press and hold “**Steam**  + **Customized** ” buttons simultaneously.
- All custom settings will revert to factory defaults.
- Five consecutive buzzer beeps.

ESPRESSO COOL

1. Enter Adjustment Mode



- Simultaneously press “Espresso Cool  + Steam ” buttons to enter coffee volume adjustment mode.
- **Note: Adjustable range for Espresso Cool is 12s (min) – 50s (max).**

2. Confirm Settings

- Press the **Espresso Cool button again** to confirm adjustment.
- The buzzer will sound three beeps (“beep-beep-beep”) to confirm successful setting.



3. Factory Reset

In standby mode:

- Press and hold “Steam  + Customized ” buttons simultaneously.
- All custom settings will revert to factory defaults.
- Five consecutive buzzer beeps.

AMERICANO

1. Enter Adjustment Mode



- Simultaneously press “Americano  + Steam ” buttons to enter coffee volume adjustment mode.
- **Note: Adjustable range for Americano is 30s (min) – 90s (max).**

2. Confirm Settings

- Press the **Americano button again** to confirm adjustment.
- The buzzer will sound three beeps (“beep-beep-beep”) to confirm successful setting.



3. Factory Reset

In standby mode:

- Press and hold “Steam  + Customized ” buttons simultaneously.
- All custom settings will revert to factory defaults.
- Five consecutive buzzer beeps.

GRINDING

1. Enter Adjustment Mode



- Simultaneously press “Grinding  + Steam ” buttons to enter coffee volume adjustment mode.
- **Note: Adjustable range for Grinding is 5s (min) – 30s (max).**

2. Confirm Settings

- Press the **Grinding button again** to confirm adjustment.
- The buzzer will sound three beeps (“beep-beep-beep”) to confirm successful setting.



3. Factory Reset

In standby mode:

- Press and hold “Steam  + Customized ” buttons simultaneously.
- All custom settings will revert to factory defaults.
- Five consecutive buzzer beeps.

GRINDING X2

1. Enter Adjustment Mode



- Simultaneously press “Grinding x2  + Steam ” buttons to enter coffee volume adjustment mode.
- **Note: Adjustable range for Grinding x2 is 5s (min) – 30s (max).**

2. Confirm Settings

- Press the **Grinding x2 button again** to confirm adjustment.
- The buzzer will sound three beeps (“beep-beep-beep”) to confirm successful setting.

3. Factory Reset

In standby mode:

- Press and hold “Steam  + Customized ” buttons simultaneously.
- All custom settings will revert to factory defaults.
- Five consecutive buzzer beeps.

COFFEE MAKING

ESPRESSO

Preparation

1. Power On & Standby

- Connect power supply.
- Press the on/off switch All function keys illuminate.
- Machine enters standby mode (**No auto-preheating**).

2. Fill Water Tank

- Add cold water between the “MIN” and “MAX” marks.
- **NOTE: It is recommended to fill the water tank with soft or purified water only. Do not use warm or hot water.**

3. Preheat the Boiler:

- Briefly press the Espresso button (without adding coffee) to preheat the coffee boiler for optimal extraction.

4. Coffee Preparation

- Place beans in the hopper, grind, and transfer to the brew head.
- **Select grind size (see p.10-11).**

5. Brewing Espresso

1. Place a heat-resistant cup on the drip tray's metal coaster.
2. Touch the “ESPRESSO” button to start the machine.
 - **Flashing icon:** The machine is preheating.
 - **Solid (steady) light:** Brewing has begun.
3. Completion: Three beeps signal your espresso is ready.

6. Post-Brewing

- After operation completes, the machine enters standby mode.
- If inactive for 5 minutes, it switches to sleep mode (screen turns off).
- Touch the screen to wake it back to standby mode.

ESPRESSO COOL

ICED COFFEE BREWING INSTRUCTIONS

1. Fill Water Tank

- Add cold water between the “MIN” and “MAX” marks.
- **NOTE: It is recommended to fill the water tank with soft or purified water only. Do not use warm or hot water.**

2. Power On & Standby

- Connect power supply.
- Press the on/off switch All function keys illuminate.
- Machine enters standby mode (**No auto-preheating**).

3. Coffee Preparation

- Place beans in the hopper, grind, and transfer to the brew head.

- **Select grind size (see p.10-11).**

4. Brewing Process

- Place cup under portafilter.
- Press **Espresso Cool** button to:
- The machine starts working.
- After the work is completed, it automatically stops after emitting three beeps.

5. Post-Brew Auto Shutdown

- Returns to standby mode after brewing.
- Activates sleep mode after 5min inactivity (display off).

Note: The Espresso Cool function is available for initial use or after extended inactivity. To activate after Espresso mode, first discharge hot water from the boiler. The alternating icon indicates cooling is in progress. Three beeps confirm readiness for iced coffee preparation.

AMERICANO

1. Power On & Standby

- Connect power supply.
- Press the on/off switch All function keys illuminate.
- Machine enters standby mode **(No auto-preheating)**.

2. Coffee Preparation

- Place beans in the hopper, grind, and transfer to the brew head.
- **Select grind size (see p.10-11).**

3. Brewing Process

- Place cup under portafilter
- Press **AMERICANO** button to:
- The machine starts working.
- After the work is completed, it automatically stops after emitting three beeps.

4. Post-Brew Auto Shutdown

- Returns to standby mode after brewing.
- Activates sleep mode after 5min inactivity (display off).

GRINDING

1. Power On & Standby

- Connect power supply.
- Press the on/off switch All function keys illuminate.
- Machine enters standby mode (No auto-preheating).

2. Grind Selection

- Touch **1 Grind or 2 Grind** icon to start.
- 3 beeps signal grinding completion.

Note: The coffee grind size can be individually adjusted to your preferences.



3. Auto Standby

- Returns to standby mode post-grinding.
- Enters sleep mode after 5min inactivity (display off).

STEAM

MILK FROTHING INSTRUCTIONS

1. Preparation

- Pour 120-180ml fresh cold milk into milk jug.
- Ensure steam nozzle is clean and unclogged.

2. Preheating

- In standby mode, press and hold the **“Steam”** key until it blinks, indicating that the machine is heating up to steam temperature.
- When the **“Steam”** button stops blinking and remains lit, the machine is ready to produce steam.

3. Steam Purge

- Purge steam for 3-5s to clear condensation.
- Turn steam knob to standby position.

4. Frothing Technique

Nozzle position:

- Depth: 1-2cm below surface.
- Angle: 3 o'clock position.

Creating vortex:

- Start fully submerged.
- Establish steady clockwise swirl.
- Gradually raise near surface.

5. Temperature Management

- Optimal temperature: 60-65°C (stop when jug becomes hot).
- The steam flow can be adjusted using the steam control knob.

6. Shutdown

- Press **“Steam”** again to stop.
- Turn steam knob to standby position.

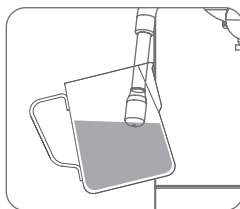

Nozzle position

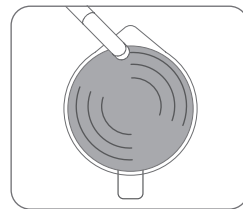

Creating vortex

CLEANING AND MAINTENANCE

CLEANING THE PORTAFILTER AND BREW HEAD

1. Before cleaning, turn off the machine and unplug it. Some metal parts may still be hot. Do not touch them with your hands before they completely cool down.
2. Please remove the portafilter and discard the used coffee grounds. To keep the basket in place while dumping the coffee grounds, please flip the portafilter basket holder and hold it with your thumb while emptying the basket.
3. Rinse thoroughly the filter and portafilter with warm soapy water. Single and double cups filters can be washed on the top rack of the dishwasher, but the portafilter cannot be washed there.
4. Wipe the bottom of the brew head with a damp cloth or paper towel to remove any remaining coffee grounds.

CLEANING THE STAINLESS STEEL STEAM WAND

1. After use, use stream to remove milk residue from the steam wand.
2. Wipe the steam wand after each use.
3. Unscrew the frothing nozzle counterclockwise to remove it.
4. Soak the frothing nozzle in water for several hours before reinstalling it or wait until the steam wand cools down. To ensure the steam wand works effectively for a long time, use a special cleaning tool to remove any blockages in the holes.

Note: Clean the steam wand according to the above instructions after each use.

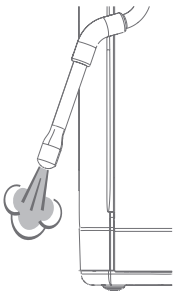

1

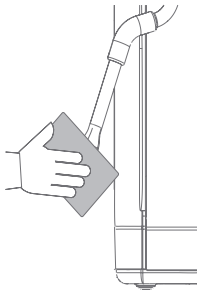

2

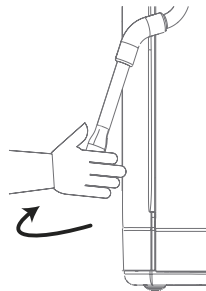

3



4

GRINDER CLEANING

1. Hold the conical burr and rotate it to the right in the direction of the arrow, until you hear a "click" sound. Unlock.
2. Pull down the conical burr.
3. Clean the coffee grounds outlet and conical burr with a brush.

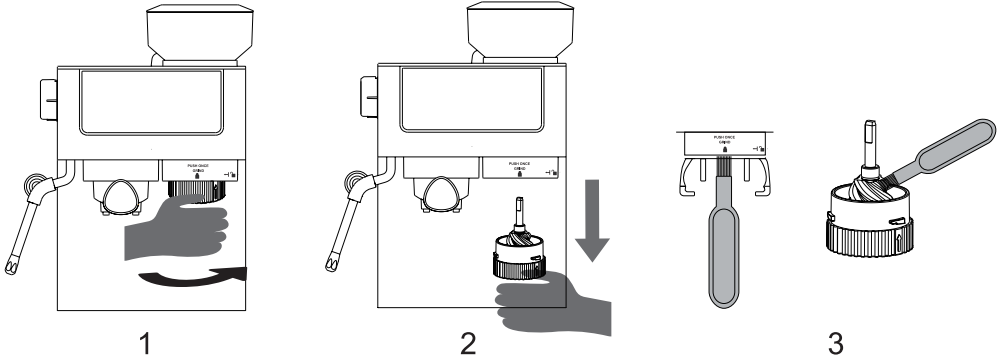

4. Hold the conical burr and insert it into the correct position.
5. Rotate it to the left in the direction of the arrow, until you hear a "click" sound that indicates it is locked.

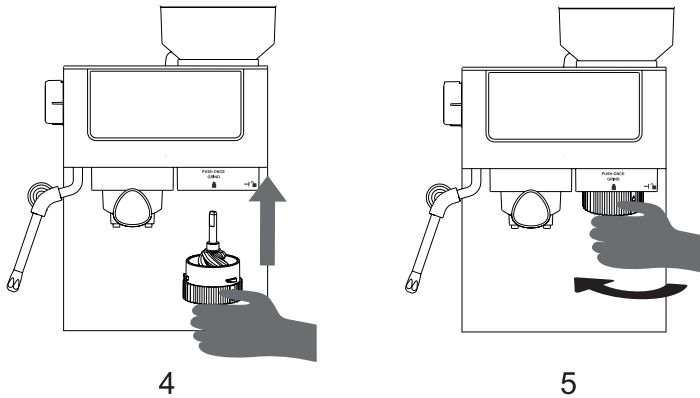

WATER TANK CLEANING

Empty the water tank after use. Pour out the remaining water in the tank, clean the tank with soapy water if necessary, and dry it. The water tank is not applicable for dishwashers.

SELF-CLEANING

1. After use for several months, the machine will remind you to clean (the system will automatically enter the cleaning mode after brewing 500 cups of coffee). The ESPRESSO and ESPRESSOx2 buttons will flash. Other function buttons will light up. Place a large cup under the brew head.
2. Press the ESPRESSO and ESPRESSOx2 buttons simultaneously to automatically enter the cleaning mode (pump water for 50 seconds, pause for 10 seconds; pump water again for 50 seconds, pause for 10 seconds; pump water again for 50 seconds, then the cleaning is completed). To exit the cleaning mode, press and hold the ESPRESSO and ESPRESSOx2 buttons for three seconds to exit the cleaning mode.

Note: In case of sudden power-off when the machine is in the cleaning process, please repeat the above steps after restarting it.

WARNINGS!

- Do not use solvents, abrasive cleaners, or alcohol to clean the coffee machine.
- Do not use metal objects to remove scale or coffee deposits.
- If the machine is left unused for more than a week, it is recommended you perform a rinse cycle before use. Danger!
- Never immerse the coffee machine in water during cleaning,
- Before starting any cleaning operation on the exterior of the machine, turn it off, unplug it from the power socket, and wait for it to cool down.

DRIP TRAY CLEANING

1. The drip tray should be regularly removed, emptied, and cleaned,
2. The storage tray can be removed and cleaned with a soft and damp cloth. Do not use abrasive cleaners, pads, or cloths that can scratch the surface.

DESCALING

1. Descaling agents may damage delicate surfaces. If the descaling agents are accidentally spilled, please wipe them up immediately.
2. Remove and empty the drip tray, then place it back into the machine.
3. Empty the water tank. (If there is any descaling agent left in the tank, place a soft ball in a glass of water until it can be reinserted at the end of the descaling process.)
4. Pour the descaling agent into the water tank until the liquid level reaches MAX.

TROUBLESHOOTING

Q1: THE MACHINE IS TURNED ON BUT HAS STOPPED OPERATING.

Due to overheating of the pump or grinder, the safety thermal cut-out may have been activated.

REMEDY

Press the power button to turn off the machine and unplug it from the power socket. Cool the machine down for 30-60 minutes. If the problem persists, please contact our customer support.

Q2: THE MACHINE'S COFFEE HEAD ISN'T DISPENSING COFFEE.

1. The machine has not reached the working temperature.
2. The water tank is empty.
3. The water tank is not fully inserted and locked into place.
4. The machine needs descaling.
5. The coffee is ground too finely, there is too much coffee in the filter basket, it is over-tamped, or the filter basket is clogged.

REMEDY

1. Allow the machine to reach the working temperature. All button lights on the control panel will be lit.
2. Fill the water tank with water.
3. Push the water tank fully down to lock it into place.
4. Refer to **"Descaling" on page 21.**
5. See below, espresso only drips from the coffee spout or does not drip at all. (Please refer to Item Q3.)

Q3: COFFEE ONLY DRIPS FROM THE COFFEE SPOUT OR DOES NOT DRIP AT ALL.

1. The coffee is ground too finely.
2. There is too much coffee in the filter basket.
3. The coffee is tamped too tightly.
4. The filter basket may be clogged.

REMEDY

1. Use slightly coarser coffee grounds.
2. Use low-dose coffee.
3. The pressure should be set between 30-40 pounds or 15-20 kilograms.
4. Use the pin at the end of the provided cleaning tool to unclog the holes. If the hole is still clogged, dissolve the cleaning tablet in the hot water, then soak the filter basket and portafilter in the solution for about 20 minutes.

Q4: THE COFFEE IS NOT HOT ENOUGH.

1. The cup is not preheated.
2. The coffee portafilter is not preheated.

REMEDY

1. Rinse the cup under the hot water outlet and then place it on the cup warming tray.
2. Rinse the coffee portafilter at the hot water outlet and dry it thoroughly.

Q5: ESPRESSO FLOWS FROM THE EDGE OF THE COFFEE CUP.

1. The portafilter is not properly inserted into the group head.
2. There are coffee grounds around the edge of the filter basket.
3. Too much coffee powder in the filter basket.

REMEDY

1. Ensure the portafilter is fully inserted and rotated until you feel resistance.
2. Clean excess coffee from the edge of the filter basket to ensure a proper seal in the brew head.
3. Low-dose coffee.

Q6: ESPRESSO IS TOO WEAK.

1. The coffee is ground too coarsely.
2. Not enough coffee in the filter basket.

REMEDY

1. Use slightly finer coffee grounds. Increase the dose of coffee powder.

Q7: THE COFFEE HAS NO CREMA.

1. The coffee is tamped too lightly.
2. The coffee is ground too coarsely.
3. The coffee beans or pre-ground coffee are not fresh.
4. The filter basket may be clogged.

REMEDY

1. The tamping pressure is set between 30-40 pounds or 15-20 kilograms.
2. Use slightly finer coffee grounds.
3. In case of grinding fresh whole coffee beans, please use freshly roasted coffee beans labeled with a "roast date" and consume them within 5-20 days following that date. For pre-ground coffee, please use it within one week after it is ground.
4. Use the pin at the end of the provided cleaning tool to unclog the hole. If the hole remains clogged, dissolve a cleaning tablet in the hot water and soak the filter basket and spout in the solution for about 20 minutes. Rinse thoroughly.

Q8: THE MACHINE IS NOT HEATING. WHEN THE MACHINE IS TURNED ON, THE STEAM BUTTON LIGHT IS FLASHING.

The steam knob is not in the standby position.

REMEDY

Turn the steam knob to the standby position. The machine will start heating.

Q9: NO STEAM

1. The machine has not reached the working temperature.
2. The water tank is empty.
3. The water tank is not fully inserted and locked into place.
4. The machine needs descaling.
5. The steam wand is clogged.
6. The steam knob is not in the steam position.

REMEDY

1. Allow the machine to reach the working temperature. The steam button is flashing, indicating that the machine is heating up to produce steam. During this time, the condensation may be discharged from the steam wand, which is normal. When the steam button stops flashing, the steam wand is ready to use.
2. Add water to the water tank.
3. Push the water tank down to lock it
4. Refer to **“Descaling” on page 21.**
5. Refer to **“Stainless Steel Steam Pipe Cleaning” on page 19.**
6. Ensure the steam knob is fully rotated to the steam position.

Q10: THE GRINDER IS NOT PRODUCING GROUND COFFEE.

1. There are no coffee beans in the bean hopper.
2. Grinding chamber is clogged.
3. There is water/moisture in the grinding chamber.

REMEDY

1. Pour fresh coffee beans into the bean hopper
2. Clean and clear the grinder. Please refer to **“Grinder Cleaning” on Page 20.**
3. Clean and clear the grinder. Please refer to **“Grinder Cleaning” on Page 20.** Ensure the burrs are completely dry before reassembly. You can use a hair dryer to blow air into the grinding chamber.

Q11: THE GRINDER IS MAKING A LOT OF NOISE.

There is a blockage or foreign object inside the grinder.

REMEDY

Remove the hopper and check for debris or blockages. If necessary, clean and clear the grinder chamber and chute. Refer to **“Grinder Cleaning” on Page 20.**

WARRANTY

Product Name	Model Number	Default Warranty Period	Date of Purchase	Order Number	For your own reference, we strongly recommend that you record your order number and date of purchase.
COFFEE MAKER	BCM2316	2 years			

TERMS & POLICY

AIRMOSEN warrants all products to be of the highest quality in material, craftsmanship, and service, effective from the date of purchase to the end of the warranty period.

AIRMOSEN will replace any product found to be defective due to manufacturer flaws based on eligibility. Refunds are available within the first 30 days of purchase. Refunds are only available to the original purchaser of the product. This warranty extends only to personal use and does not extend to any product that has been used for commercial, rental, or any other use in which the product is not intended for. There are no warranties other than the warranties expressly set forth with each product.

This warranty is non-transferrable. AIRMOSEN is not responsible in any way for any damages, losses, or inconveniences caused by equipment failure by user negligence, abuse, or use noncompliant with the user manual or any additional safety or usage warnings included in the product packaging and manual.

THIS WARRANTY DOES NOT APPLY TO THE FOLLOWING:

- Damage due to abuse, accident, alteration, misuse, tampering, or vandalism.
- Improper or inadequate maintenance.
- Damage in return transit.
- Unsupervised use by children under 18 years of age.

AIRMOSEN assume no liability for damage caused by the use of the product other than for its intended use or as instructed in the user manual. Some states do not allow this exclusion or limitation of incidental or consequential losses, so the foregoing disclaimer may not apply to you. This warranty gives you specific legal rights and you may also have other rights, which may vary from state to state.

ALL EXPRESSED AND IMPLIED WARRANTIES, INCLUDING THE WARRANTY OF MERCHANTABILITY, ARE LIMITED TO THE PERIOD OF THE LIMITED WARRANTY.

DEFECTIVE PRODUCTS & RETURNS

Should your product prove defective within the specified warranty period, please contact Customer Support via support@airmsen.com with your order number. DO not dispose of your product before contacting us. Once our Customer Support Team has approved your request, please return the unit with a copy of your invoice and order number.

CUSTOMER SUPPORT

WE'RE HERE TO HELP!

If you encounter any issues or have any questions regarding your new product, please contact our helpful Customer Support Team. Your satisfaction is our goal!

CUSTOMER SUPPORT

Email: **support@airmsen.com**

Website: **www.airmsen.com**

If you need to purchase product accessories, please visit **www.airmsen.com**.

* Please have your order confirmation number ready before contacting Customer Support.



<https://www.facebook.com/Airmsen>



<https://www.youtube.com/@AIRMSEN>

For product operation videos, please subscribe to AIRMSEN's official Youtube account.

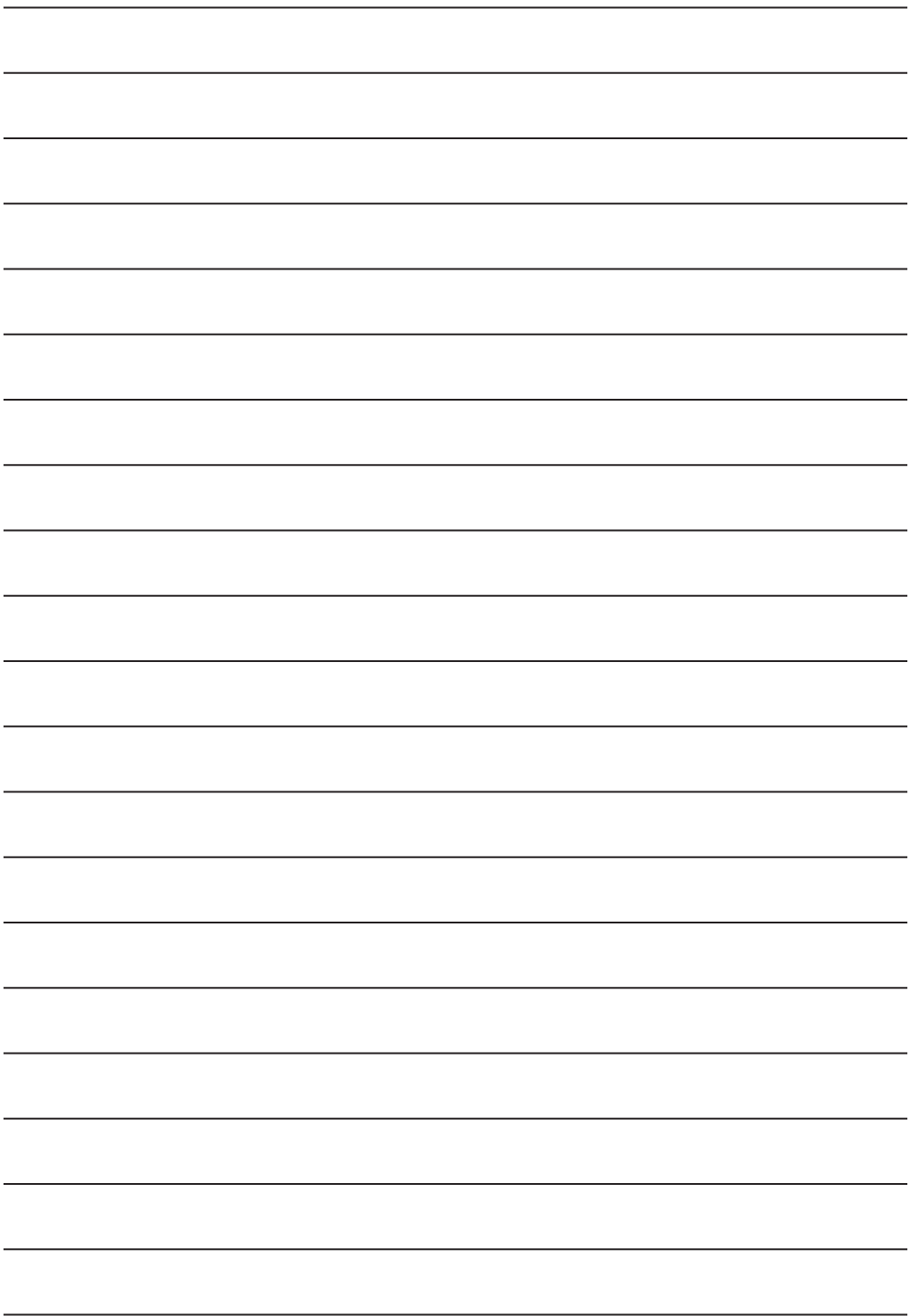

AIRMSSEN

QUESTIONS OR COMMENTS?

EMAIL	OR VISIT US ONLINE AT
support@airmsen.com	www.airmsen.com

