

Assembly | Asambla | Assemblage

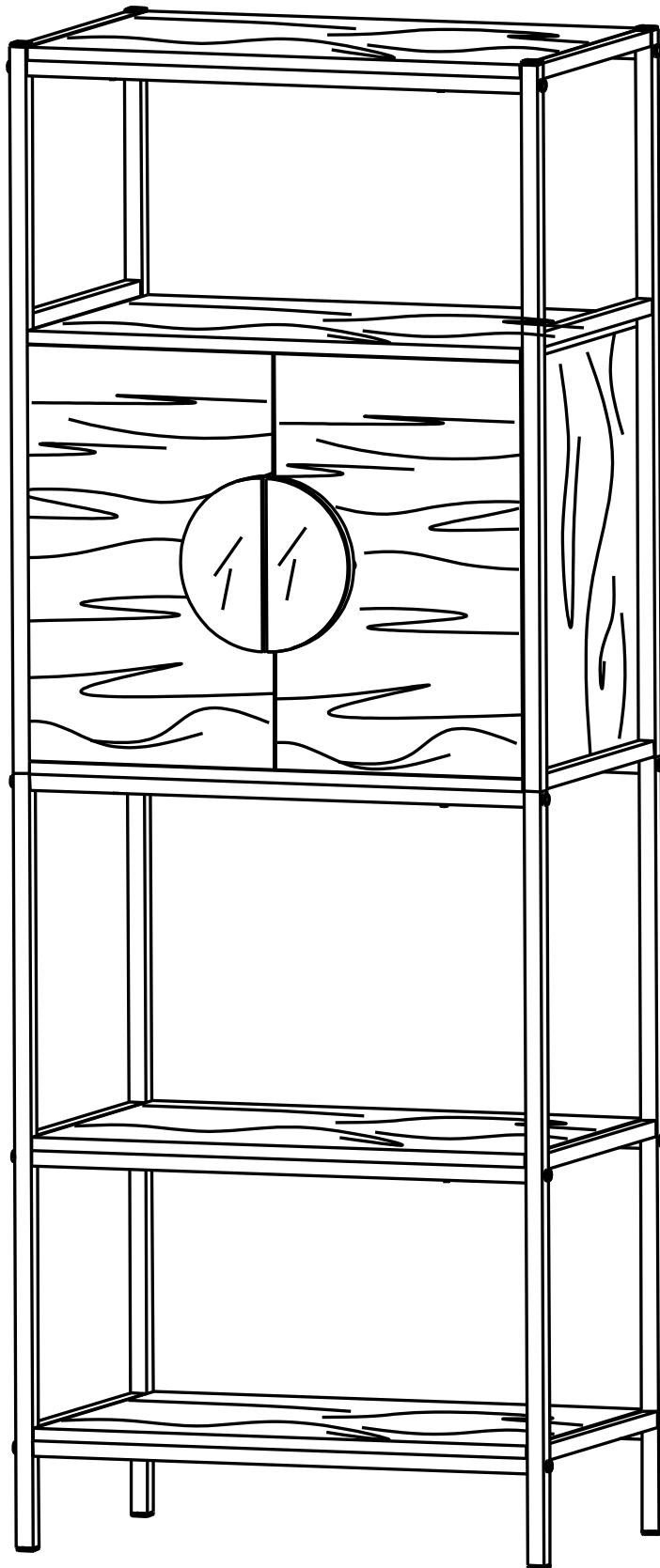

Assembly | Asamblea | Assemblage

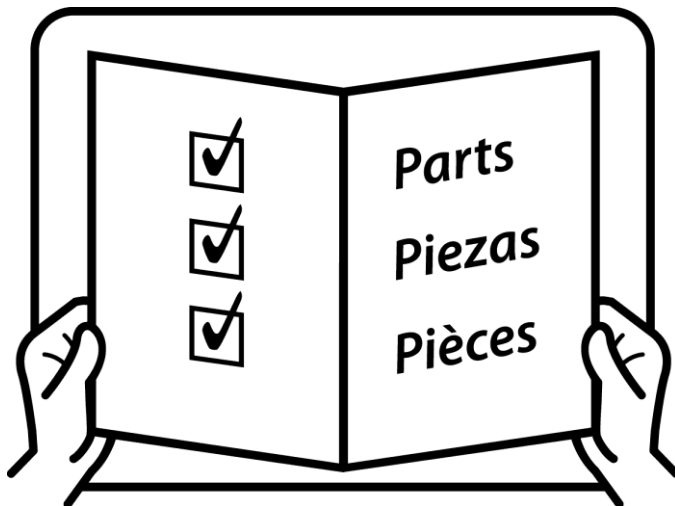
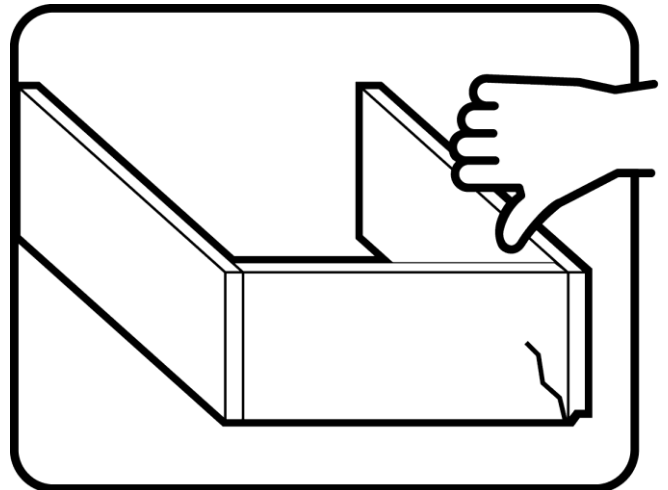
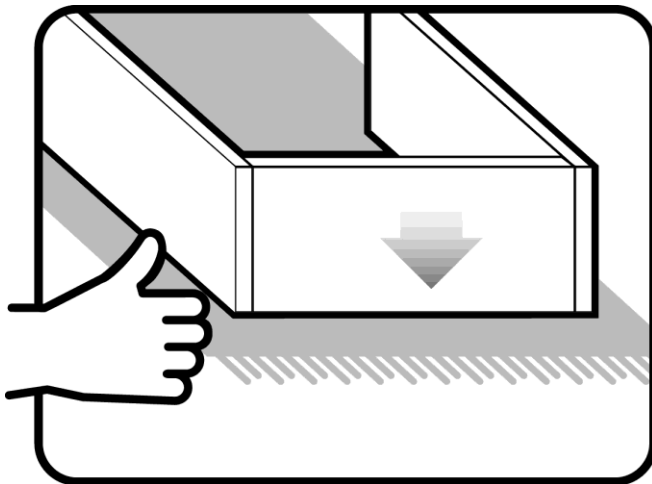
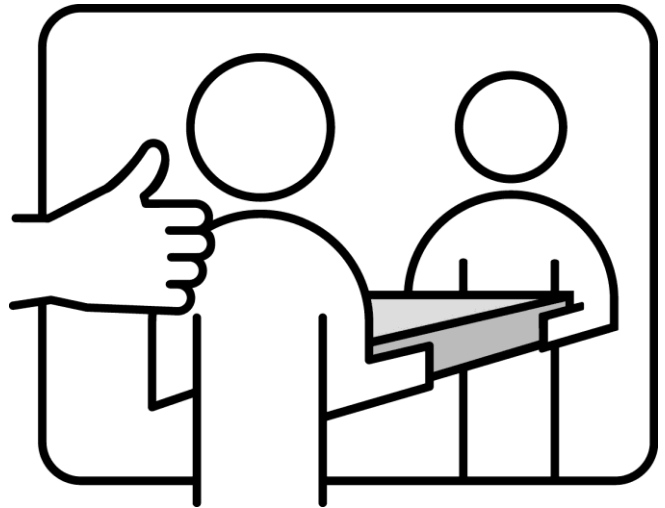
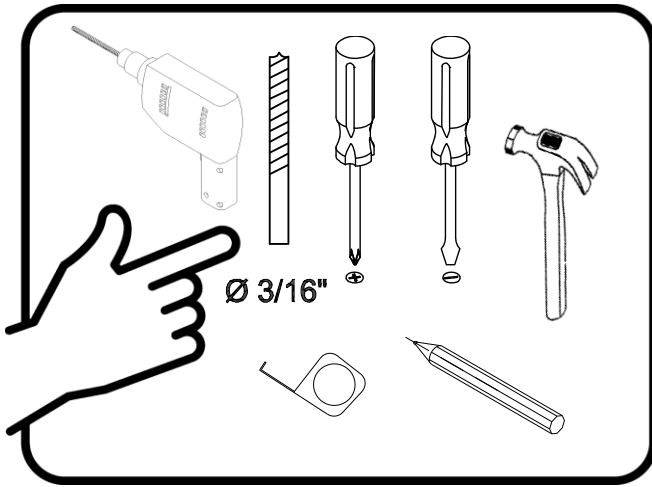

Assembly | Asamblea | Assemblage

Techniques | Técnicas | Techniques

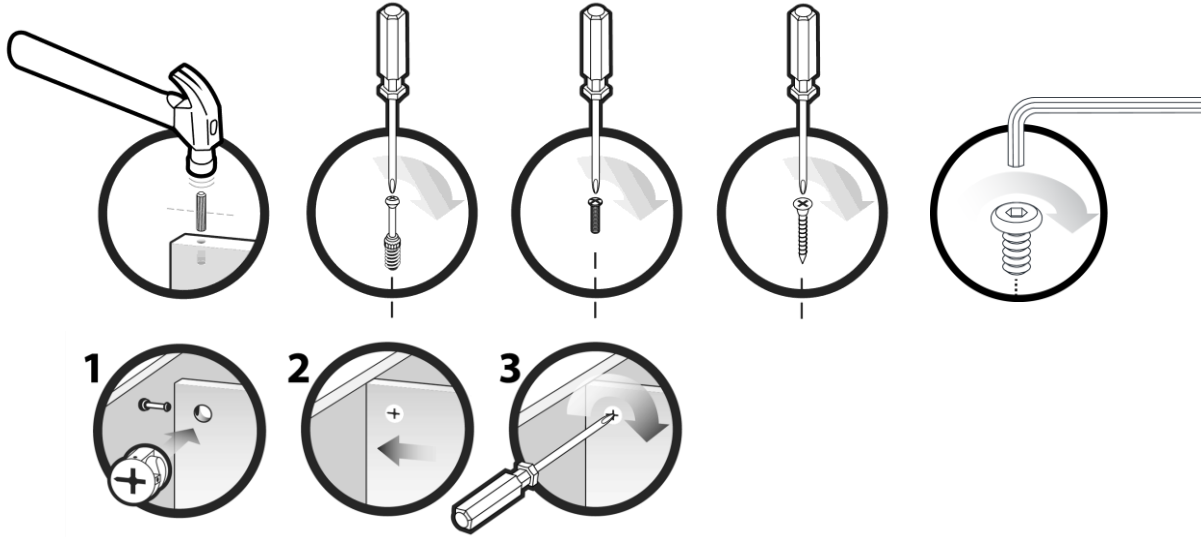

Care | Cuidado | Entretien

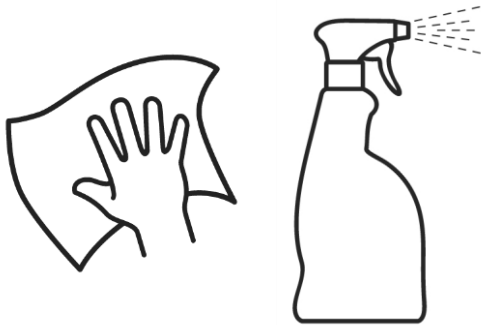



Safety | Seguridad | Sécurité







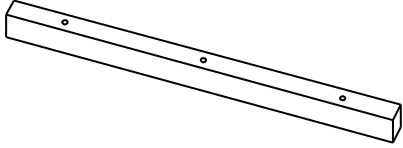
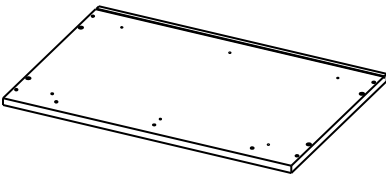
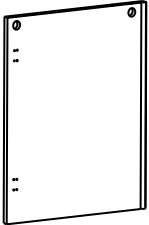
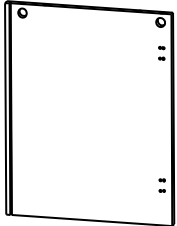
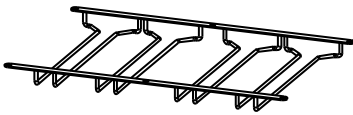
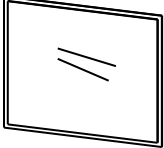
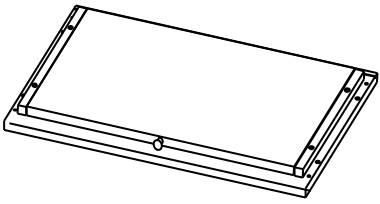
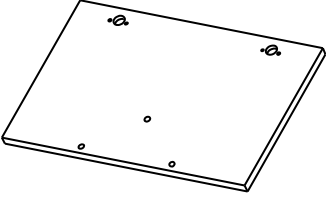

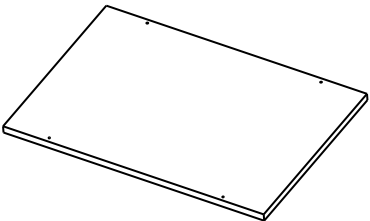
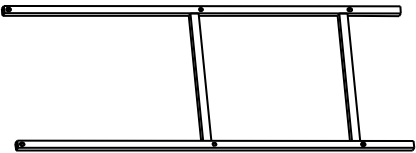
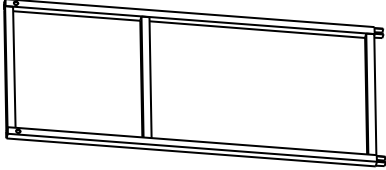
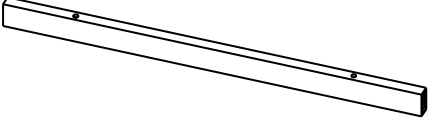

Note! | ¡Nota! | Remarque!

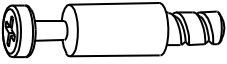

Assembly | Asamblea | Assemblage

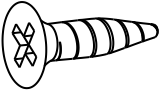
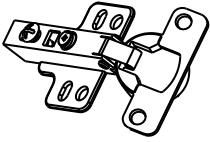
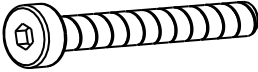
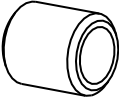
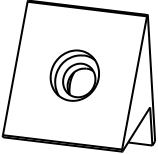
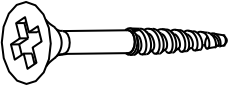
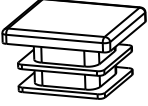
<p>1 x1</p>  <p>Wood stretcher A Camilla de madera A Civière en bois A</p>	<p>2 x1</p>  <p>Cabinet top panel Panel superior del gabinete Panneau supérieur d'armoire</p>	<p>3 x1</p>  <p>Cabinet left panel Panel izquierdo del armario Panneau gauche du meuble</p>
<p>4 x1</p>  <p>Cabinet right panel Panel derecho del armario Panneau droit de l'armoire</p>	<p>5 x1</p>  <p>Wine glass rack Estante para copas de vino Casier à verres à vin</p>	<p>6 x1</p>  <p>Cabinet interior mirror Espejo interior de armario Miroir d'intérieur de meuble</p>
<p>7 x1</p>  <p>Cabinet bottom panel Panel inferior del gabinete Panneau de fond d'armoire</p>	<p>8 x2</p>  <p>Door Puerta Porte</p>	<p>9 x2</p>  <p>Door handle Manija de la puerta Poignée de porte</p>
<p>10 x3</p>  <p>Wood shelf Estante de madera Étagère en bois</p>	<p>11 x2</p>  <p>Bottom side frame Marco lateral inferior Cadre latéral inférieur</p>	<p>12 x2</p>  <p>Top side frame Marco lateral superior Cadre latéral supérieur</p>
<p>13 x8</p>  <p>Metal stretcher Camilla de metal Civière en métal</p>		

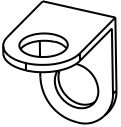
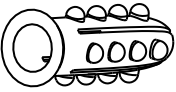
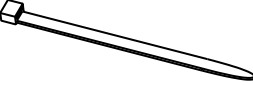

Assembly | Asamblea | Assemblage

<p>A x4</p>  <p>Cam bolt Perno de leva Boulon à came 6x38mm</p>	<p>B x8</p>  <p>Wood dowel Clavija de madera Cheville en bois 8x30mm</p>	<p>C x25</p>  <p>Screw Tornillo Vis 8x1-1/8" L</p>	<p>D x4</p>  <p>Cam lock Bloqueo de leva Serrure à came 15mm</p>
<p>E x30</p>  <p>Screw Tornillo Vis 8x5/8"</p>	<p>F x4</p>  <p>Hinge Bisagra Charnière</p>	<p>G x22</p>  <p>Bolt Tornillo Boulon 1/4" x 1-3/4"</p>	<p>H x6</p>  <p>Round tube Tubo redondo Tube rond 20mm</p>
<p>I x4</p>  <p>Corner bracket Soporte de esquina Support d'angle</p>	<p>J x4</p>  <p>Screw Tornillo Vis 2.8x18mm</p>	<p>K x8</p>  <p>End cap Tapa final Embout 20/20</p>	<p>L x16</p>  <p>Bolt cover Cubierta de perno Couvercle de boulon 14mm</p>
<p>M x2</p>  <p>L Bracket Soporte L Support en L</p>	<p>N x2</p>  <p>Wall anchor Ancla de pared Ancrage mural</p>	<p>O x2</p>  <p>Plastic strap Correa de plastic Sangle en plastique</p>	<p>P x1</p>  <p>Allen wrench Llave Allen Clé Allen</p>

Assembly | Asambla | Assemblage

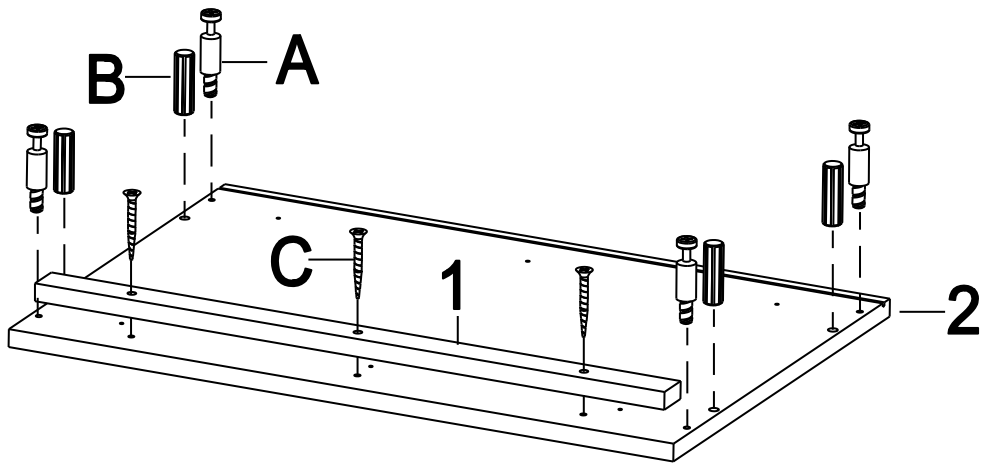
1

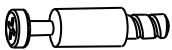

A		X4
B		X4
C		X3

2

D		X4
---	--	----

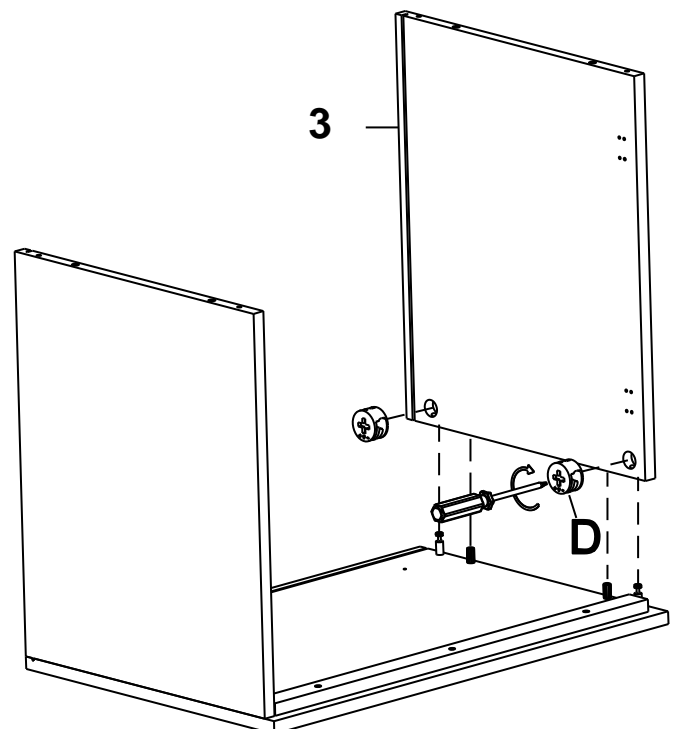
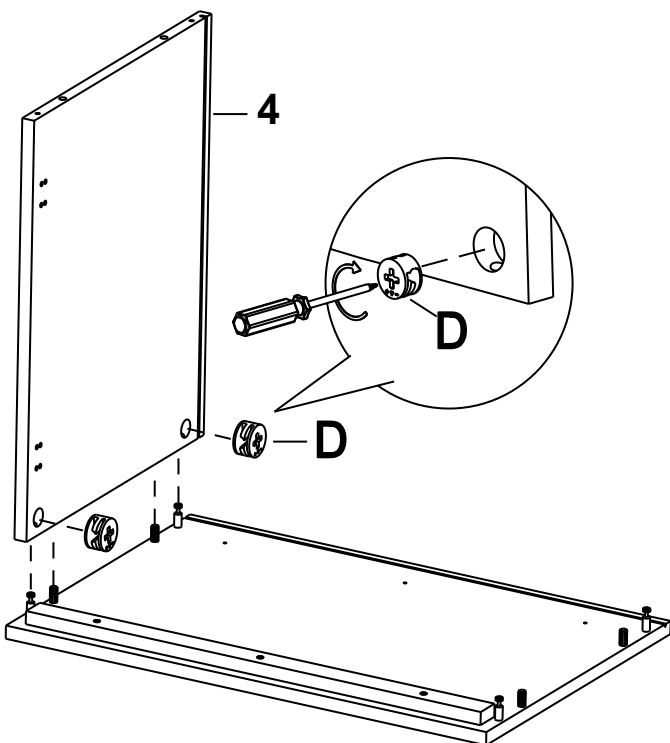

Assembly | Asambla | Assemblage

3

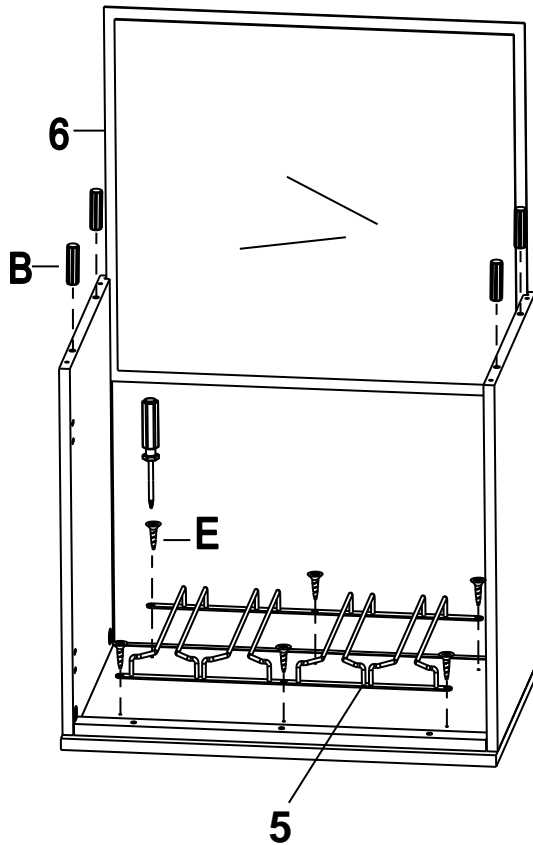

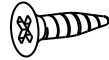
B		X4
E		X6

4

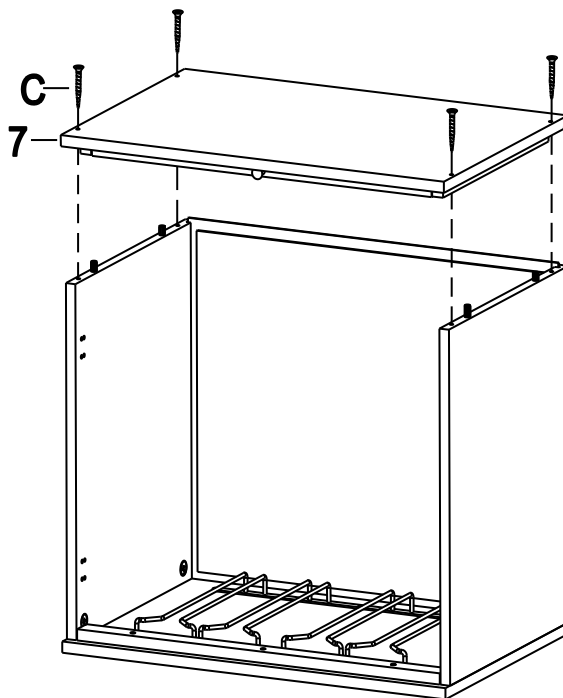



C		X4
----------	---	-----------

Assembly | Asambla | Assemblage

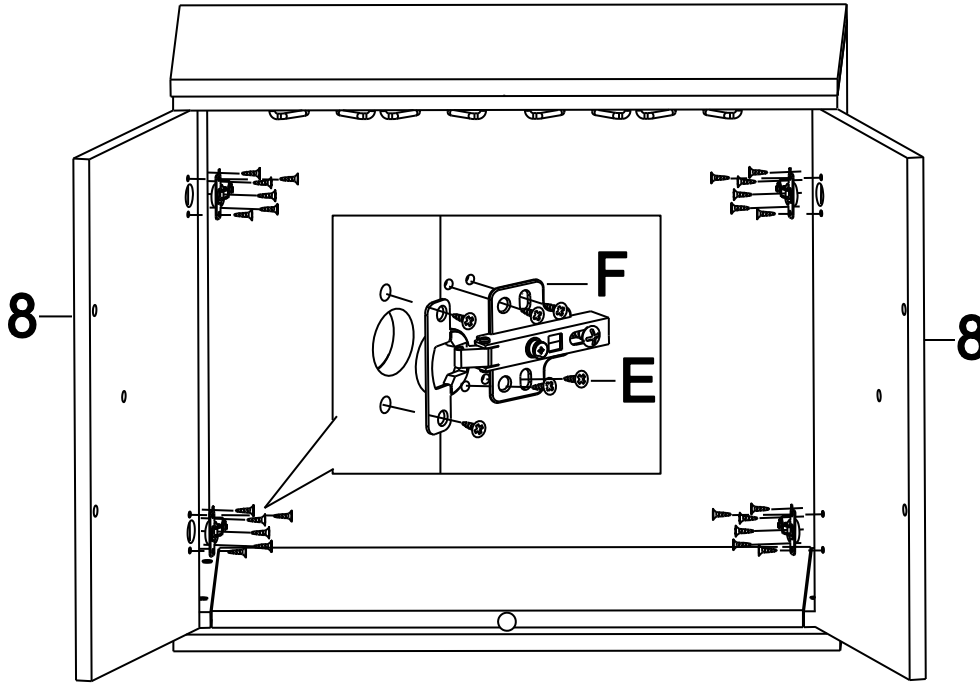

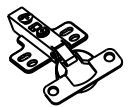
5

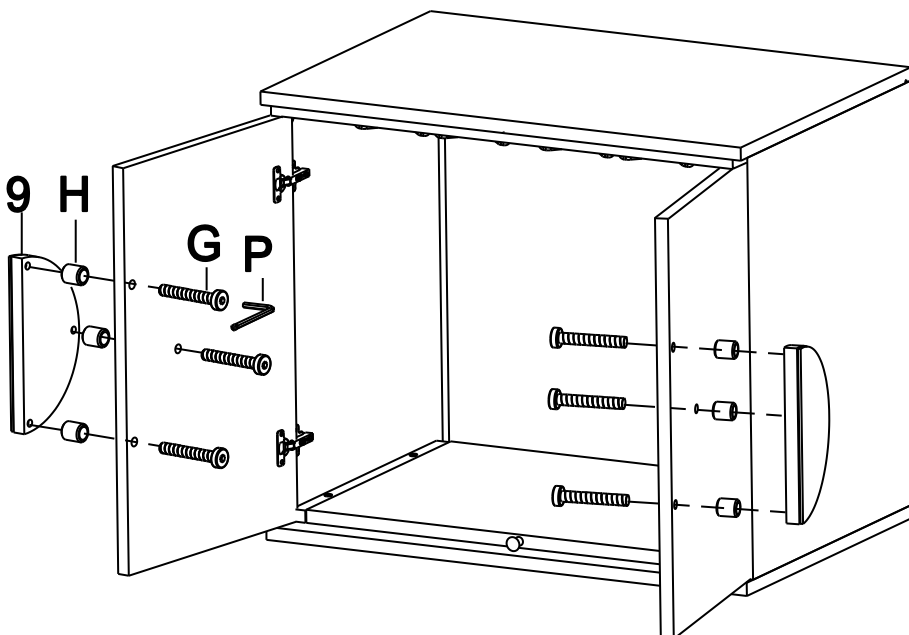

F		X4
E		X24

6

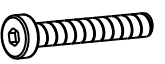

G		X6
H		X6

Assembly | Asambla | Assemblage

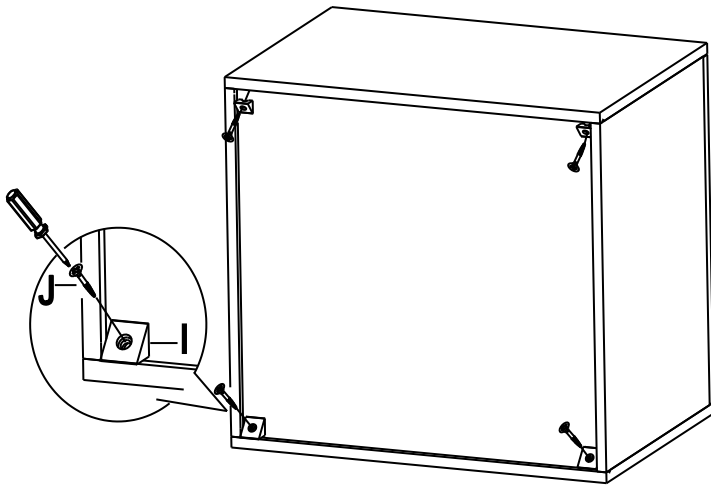

7

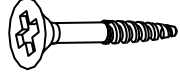
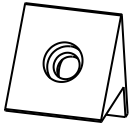

J		X4
I		X4

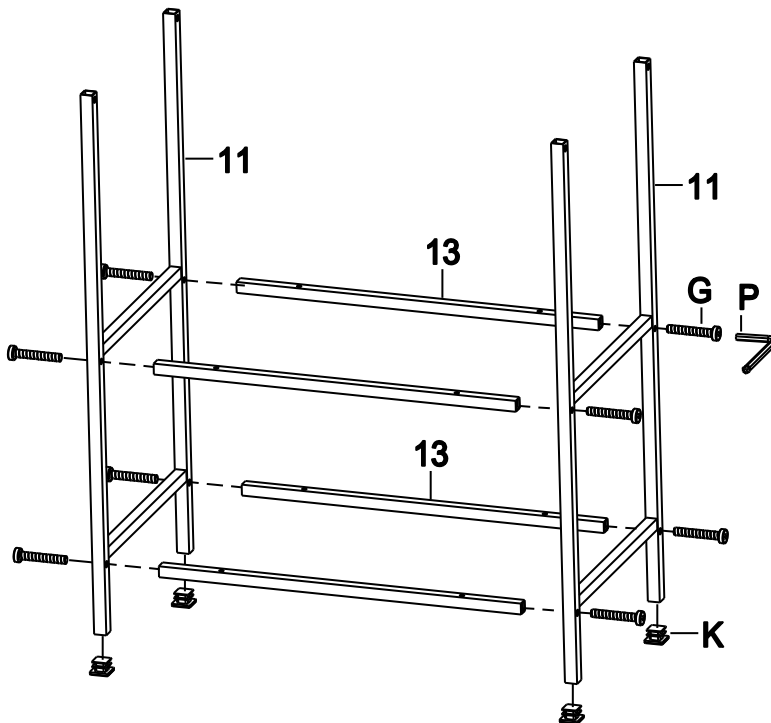
8

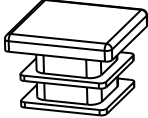



G		X8
K		X4
P		X1

Assembly | Asambla | Assemblage

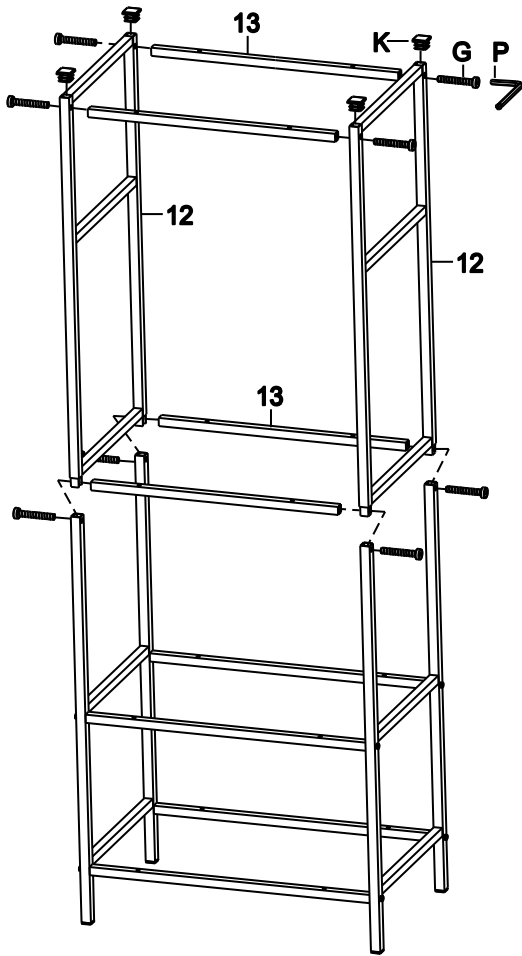
9

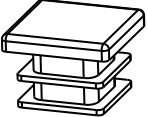

G		X8
K		X4
P		X1

10

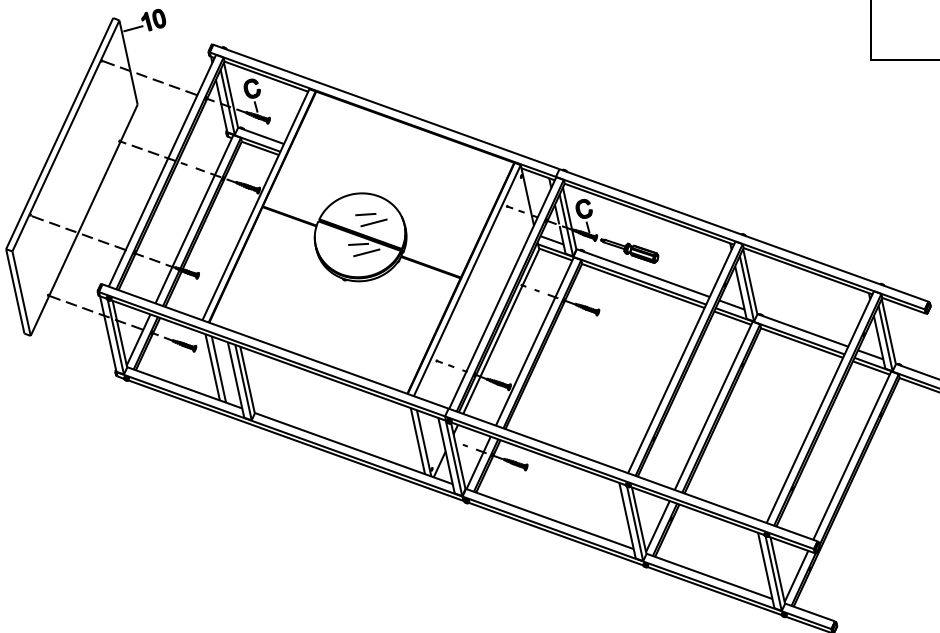



C		X8
----------	---	-----------

Assembly | Asambla | Assemblage

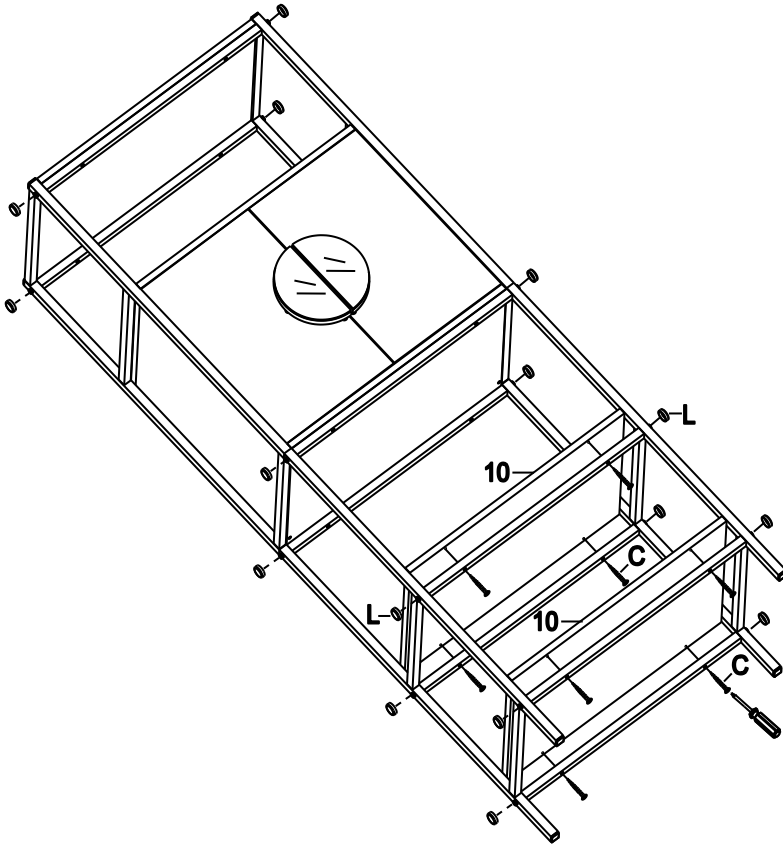
11



C		X8
L		X16

12

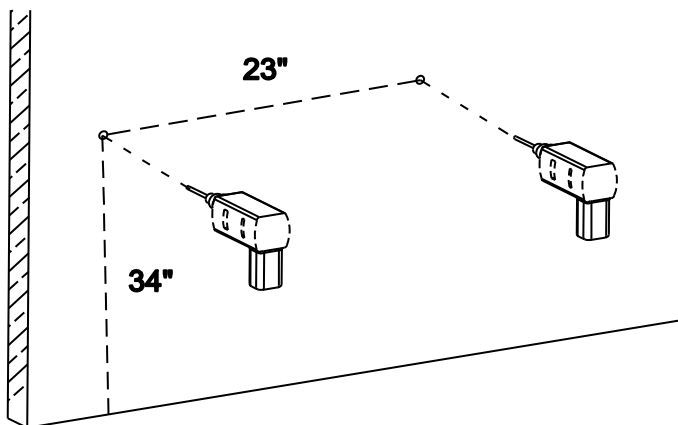

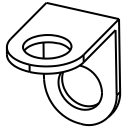
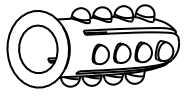
C		X2
M		X2
N		X2

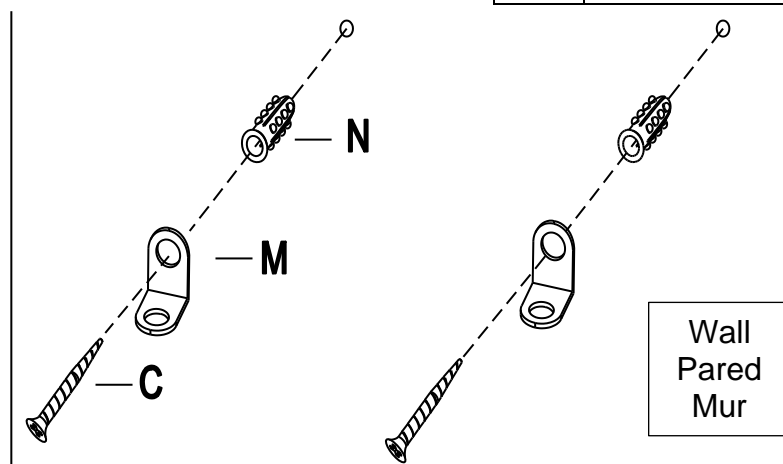

Assembly | Asambla | Assemblage

13

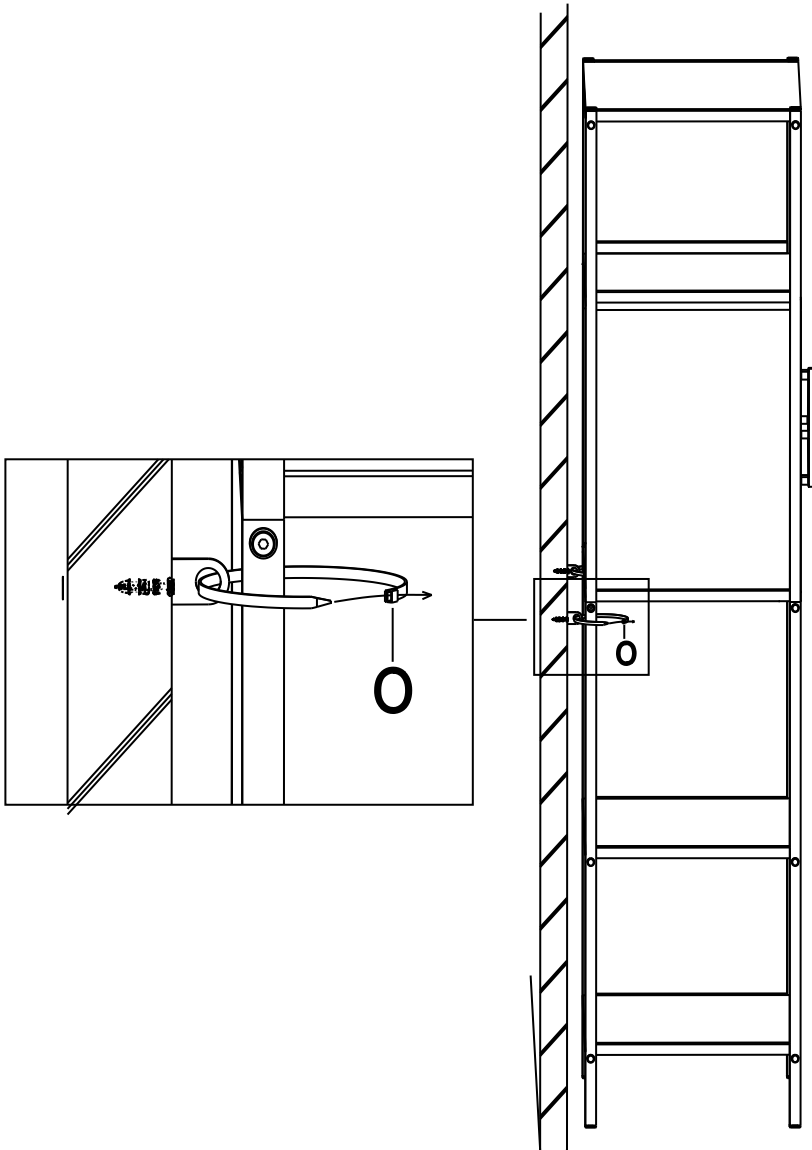

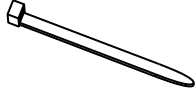
O		X2
---	---	----

Assembly | Asamblea | Assemblage

Replacement Parts or Damages

YOU should examine your merchandise promptly upon receipt. For product concerns, please contact customer service. Please have your purchase information ready when you call.

Requests for missing or damaged parts must be requested within one year of purchase. Damages or missing parts reported outside of one year will not be honored. We are under no obligation to provide parts or replacement merchandise. Replacement part requests will not be honored for fully assembled or modified items.

For merchandise purchased from an online retailer, please contact their customer service for parts or returns.

Merchandise purchased as "like new," "open box," or "as is," or from private parties are exempt from replacement parts.

One Year Limited Warranty

Product warranty applies to the original purchaser with items in original factory-sealed cartons. Proof of purchase date, price, and seller must be shown to validate the warranty. This warranty covers defects in manufacturing. It does not apply to any defects caused by negligence, misuse, accidental damage, or improper assembly. Glass and mirrors are excluded from this warranty. Warranty does not extend to cosmetic damage, accidents, misuse, abuse, or neglect. Liability for incidental or consequential damages is excluded to the maximum extent permitted by law.

After verification of claim, we will repair or replace any defective product or missing part. If the defective item must be returned in whole or in part, we will send written authorization and a pre-addressed shipping label for the return of any defective product or part.

No returns will be accepted without prior approval.

Piezas de Repuesto o Daños

Debe examinar su producto inmediatamente después de recibirlo. Si tiene alguna duda o problema, por favor, póngase en contacto con nuestro servicio de atención al cliente. Le pedimos que tenga a mano la información de su compra cuando nos contacte.

Las solicitudes por piezas faltantes o dañadas deben realizarse dentro del plazo de un año a partir de la fecha de compra. Las reclamaciones por daños o piezas faltantes informadas después de un año no serán aceptadas. No estamos obligados a proporcionar piezas o productos de reemplazo. No se aceptarán solicitudes de piezas de repuesto para artículos que hayan sido completamente ensamblados o modificados.

Para mercadería comprada en un minorista en línea, comuníquese con su servicio de atención al cliente para obtener piezas o devoluciones.

La mercancía comprada como "como nueva", "caja abierta" o "como está" o

Garantía Limitada de un Año

La garantía del producto se aplica al comprador original con los artículos en sus cajas de cartón originales y selladas de fábrica. Se debe presentar un comprobante con la fecha de compra, el precio y el vendedor para validar la garantía.

Esta garantía cubre defectos de fabricación. No se aplica a ningún defecto causado por negligencia, mal uso, daño accidental o montaje inadecuado. Los vidrios y espejos están excluidos de esta garantía. La garantía no se extiende a daños cosméticos, accidentes, mal uso, abuso o negligencia. La responsabilidad por daños incidentales o consecuentes está excluida en la medida máxima permitida por la ley.

Tras la verificación de la reclamación, nosotros repararemos o reemplazaremos cualquier producto o pieza defectuosa. Si el artículo defectuoso debe ser devuelto, total o parcialmente, le enviaremos una autorización por escrito y una etiqueta de envío para la devolución.

No se aceptarán devoluciones sin nuestra aprobación previa.

Pièces de Rechange ou Dommages

Vous devez examiner votre marchandise dès sa réception. Pour toute question concernant le produit, veuillez contacter notre service client. Nous vous demandons d'avoir vos informations d'achat à portée de main lorsque vous nous contactez.

Les demandes de pièces manquantes ou endommagées doivent être effectuées dans l'année suivant l'achat. Les réclamations pour dommages ou pièces manquantes signalées après ce délai d'un an ne seront pas acceptées. Nous n'avons aucune obligation de fournir des pièces ou des produits de remplacement. Les demandes de pièces de rechange pour des articles entièrement assemblés ou modifiés ne seront pas acceptées.

Pour les marchandises achetées auprès d'un détaillant en ligne, veuillez contacter leur service client pour les pièces ou les retours.

Les articles achetés "comme neufs", "boîte ouverte" ou "en l'état", ou auprès de particuliers, ne sont pas éligibles au remplacement des pièces.

Garantie Limitée d'un An

La garantie du produit s'applique à l'acheteur d'origine pour les articles se trouvant dans leur carton d'usine d'origine scellé. Une preuve d'achat indiquant la date, le prix et le vendeur doit être présentée pour valider la garantie.

Cette garantie couvre les défauts de fabrication. Elle ne s'applique pas aux défauts causés par la négligence, une mauvaise utilisation, des dommages accidentels ou un assemblage incorrect. Le verre et les miroirs sont exclus de cette garantie. La garantie ne couvre pas les dommages esthétiques, les accidents, la mauvaise utilisation, l'abus ou la négligence. Notre responsabilité pour les dommages indirects ou consécutifs est exclue dans la mesure maximale permise par la loi.

Après vérification de la réclamation, nous réparerons ou remplacerons tout produit ou pièce défectueux ou manquant. Si l'article défectueux doit être retourné en totalité ou en partie, nous vous enverrons une autorisation écrite et une étiquette d'expédition pré-adressée.

Aucun retour ne sera accepté sans notre accord préalable.