

# Assembly Instructions

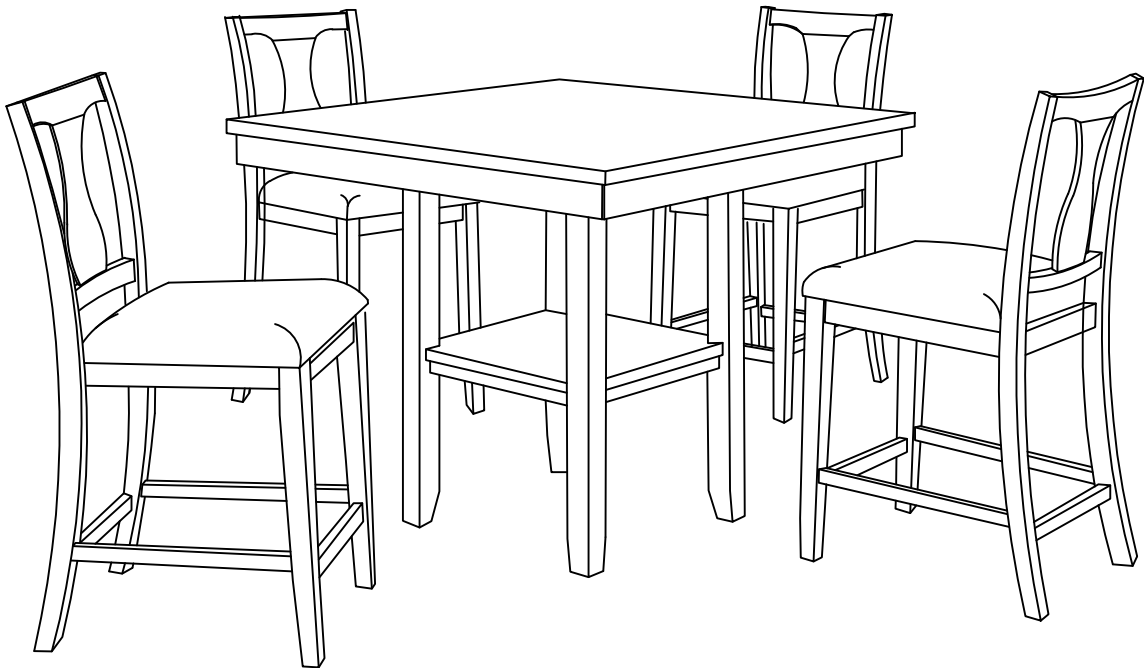

## ASSEMBLY RATING

The Assembly Rating is a 5-point system that shows the degree of effort needed in assembling a specific product (with 1 being easy and 5 being difficult). For some products, two persons are recommended.

EASY  DIFFICULT

## Tools Required For Assembly:

Wrench



(Included)

Allen Wrench

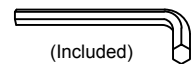

(Included)

Phillips Screwdriver

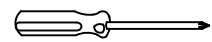

(Not Included)



2 PERSONS RECOMMENDED

# ASSEMBLY & CARE ADVICE

FOR YOUR FURNITURE TO LAST, CORRECT ASSEMBLY AND PROPER MAINTENANCE ARE NECESSARY. PLEASE FOLLOW THE INFORMATION PROVIDED BELOW TO FULLY ENJOY YOUR FURNITURE.

## BASIC ASSEMBLY TECHNIQUES

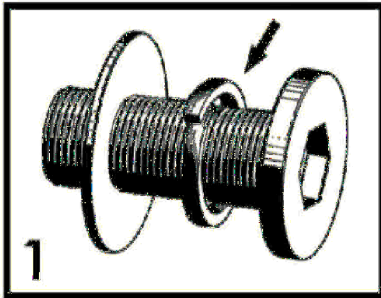

1  
When lock or spring washer is used in an assembly, please make sure the lock or spring washer is placed between the larger flat washer and the head of the screw or bolt.

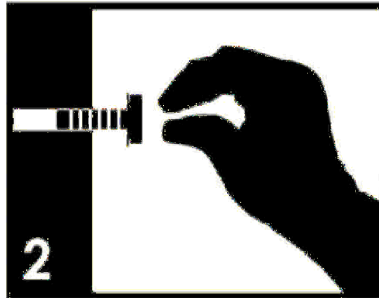

2  
Position each part correctly and insert screws or bolts into their respective holes by hand tighten or using the proper hand tool. Only tighten when step is completed or when instructed to do so.

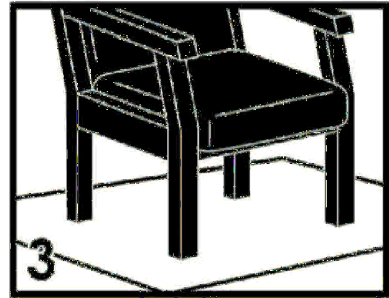

3  
Use cardboard or carpet area when assembling furniture to prevent scratches. Make sure the furniture rests on a flat and level surface with each leg evenly touching the floor. No dragging of products/parts.

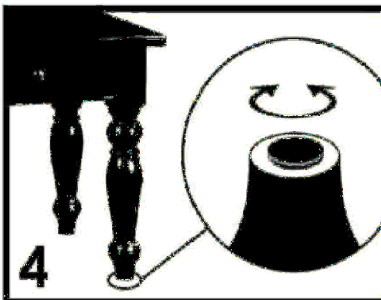

4  
Some furniture comes with height adjustment knobs underneath each leg. To lower or to raise each leg, you need to turn clockwise or counterclockwise, respectively.

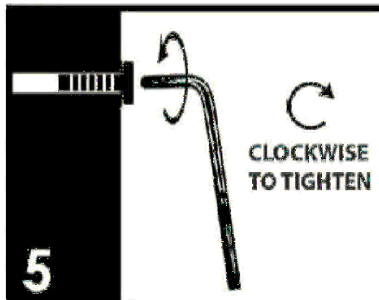

5  
Make sure all parts are properly aligned, then use the appropriate hand tool to completely tighten the bolts or screws. Do not use power tools and do not overtighten.

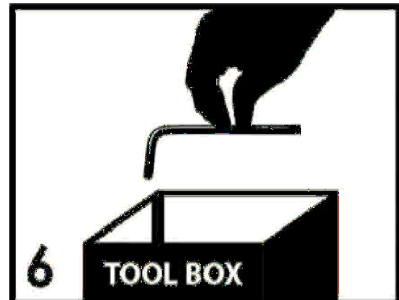

6  
Save the instructions and store the Allen wrench or any supplied tool for later maintenance. After two weeks, check and tighten any loose hardware and repeat again every six months thereafter.

IT IS THE USER'S RESPONSIBILITY TO MAINTAIN THE FURNITURE. THE HARDWARE MAY LOOSEN OVER TIME AND MAY CAUSE THE FURNITURE TO BE WOBBLY AND UNABLE TO SUPPORT ITS INTENDED WEIGHT CAPACITY. THIS MAY LEAD TO COLLAPSE AND MAY CAUSE SERIOUS INJURY.



**FAILURE TO FOLLOW THE GUIDELINES ABOVE MAY RESULT IN INJURY AND/OR PROPERTY DAMAGE.**

ALL RIGHTS RESERVED.

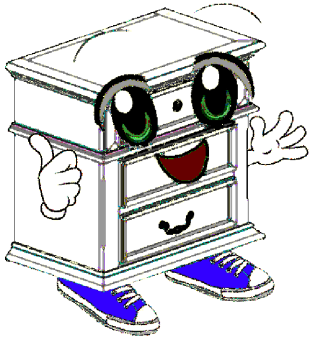

Before you begin, please read Page 2 of "Assembly and Care Advice".

And remember, do not tighten until each step is completed or instructed.

### Parts List

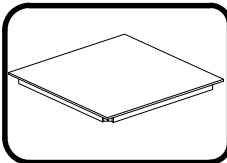

#1 x 1pc  
Table Top

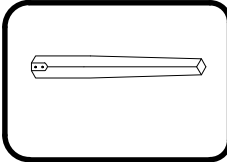

#2 x 4pcs  
Table Leg

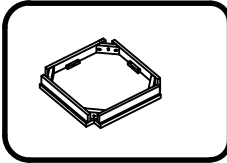

#3 x 1pc  
Shelf

### Hardware List

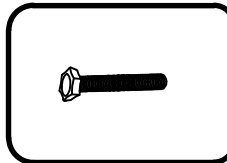

#A x 12pcs  
Bolt Ø5/16" x 2-1/2"

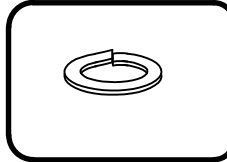

#B x 12pcs  
Spring Washer Ø5/16"

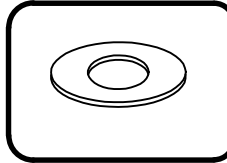

#C x 12pcs  
Flat Washer Ø5/16"

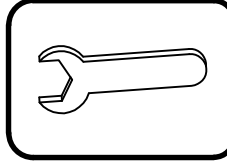

#D x 1pc  
Wrench 12mm

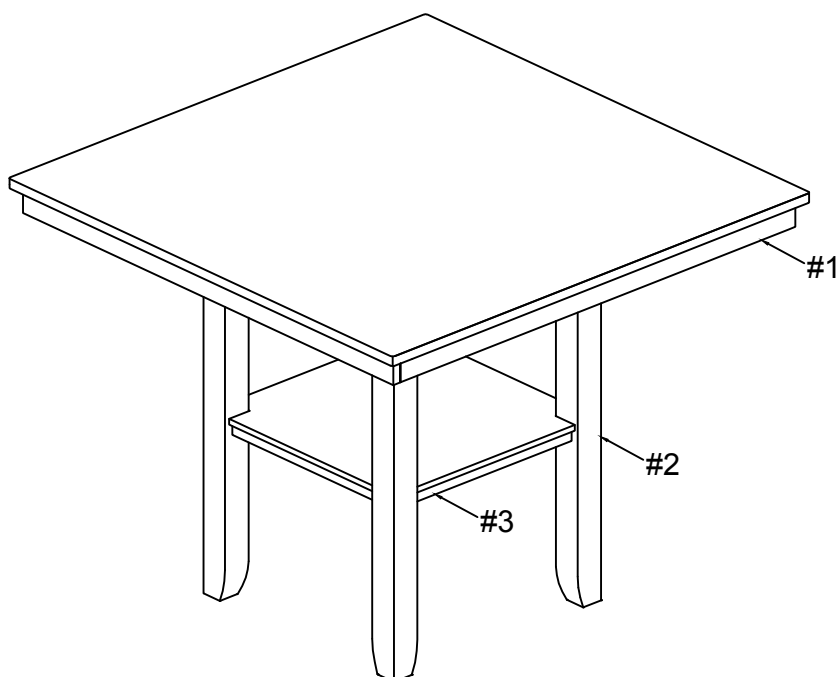



Align legs (#2) to the table top (#1), then secure by using bolts (#A) with washers (#B,C).

- #A x 8pcs
- #B x 8pcs
- #C x 8pcs

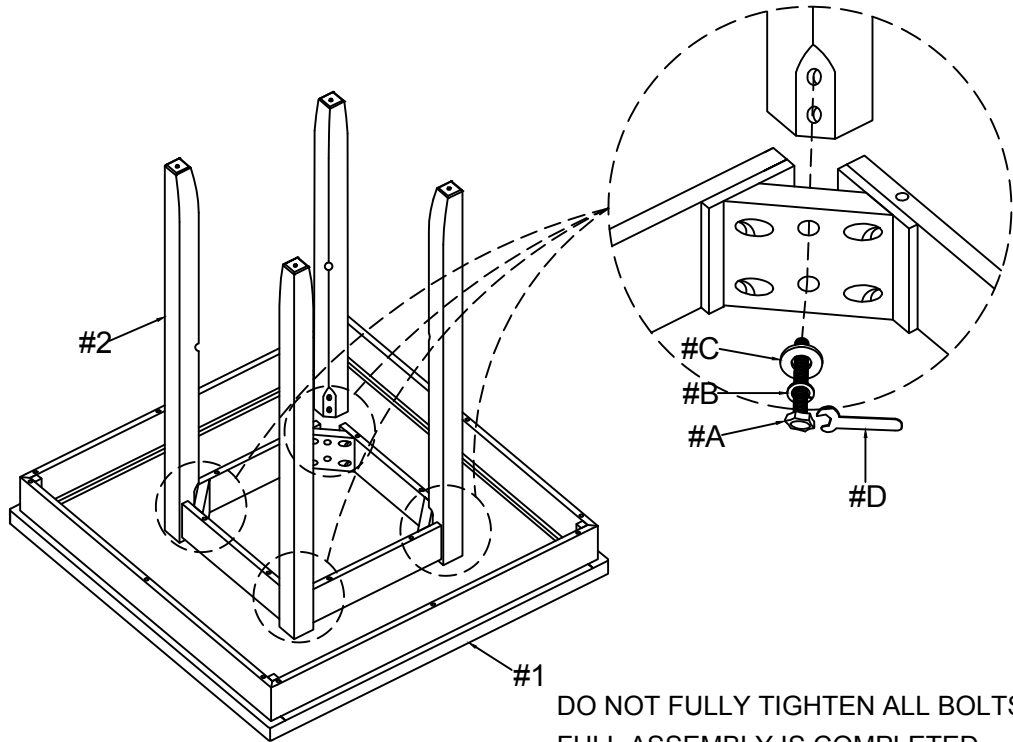

Align shelf (#3) to the holes of the legs (#2), then secure by using bolts (#A) with washers (#B,C).

- #A x 4pcs
- #B x 4pcs
- #C x 4pcs

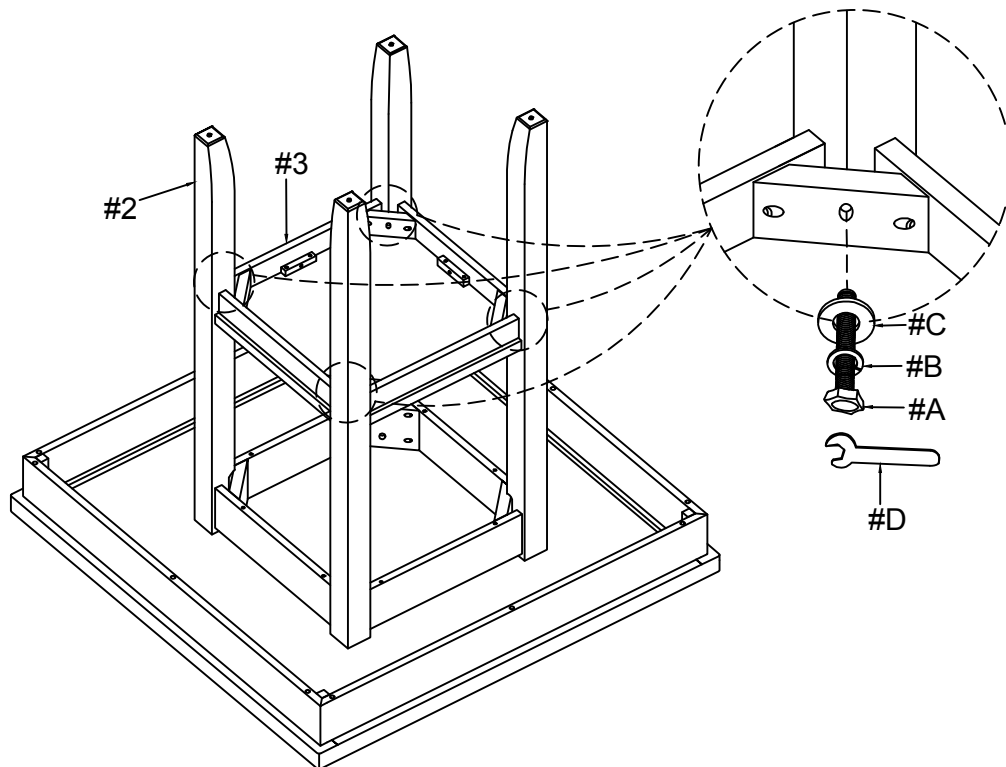

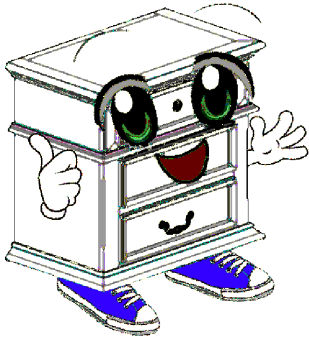



Before you begin, please read Page 2 of "Assembly and Care Advice".

And remember, do not tighten until each step is completed or instructed.

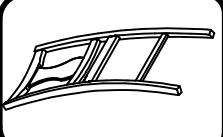
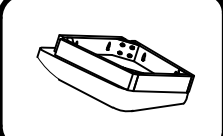
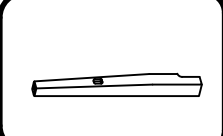
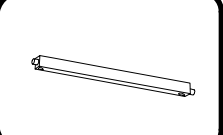
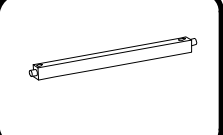
### Parts List

- 
#1 x 1pc x 4  
Chair Back
- 
#2 x 1pc x 4  
Seat
- 
#3 x 2pcs x 4  
Front Leg (L/R)
- 
#4 x 2pcs x 4  
Side Stretcher (L/R)
- 
#5 x 1pc x 4  
Front Stretcher

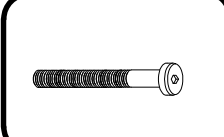
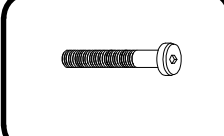
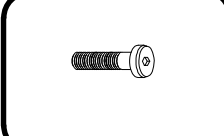
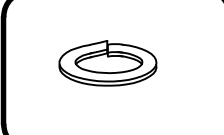
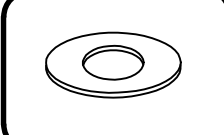
### Hardware List

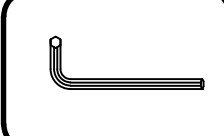
- 
#A x 4pcs x 4  
Bolt Ø1/4" x 3"
- 
#B x 4pcs x 4  
Bolt Ø1/4" x 2-1/2"
- 
#C x 2pcs x 4  
Bolt Ø1/4" x 1-1/2"
- 
#D x 10pcs x 4  
Lock Washer Ø1/4"
- 
#E x 10pcs x 4  
Flat Washer Ø1/4"
- 
#F x 6pcs x 4  
Screw #8 x 1-3/4"
- 
#G x 1pc x 4  
Allen Wrench M4

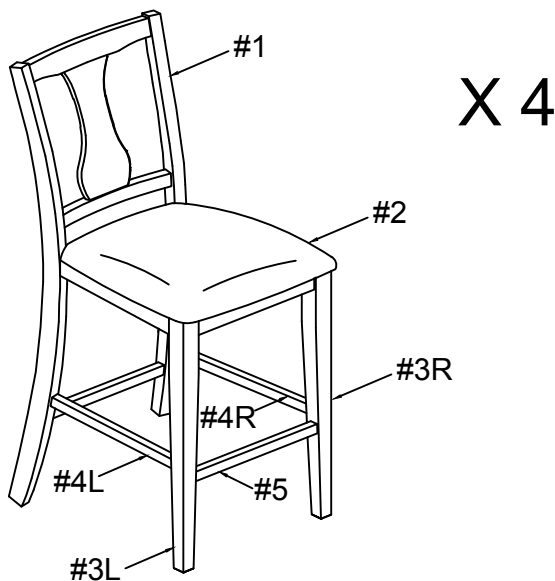



Align seat (#2) to the holes of the chair back (#1), then secure 2 middle holes of the seat (#2) to chair back (#1) by using bolts (#C) with washers (#D,E).

- #C x 2pcs
- #D x 2pcs
- #E x 2pcs

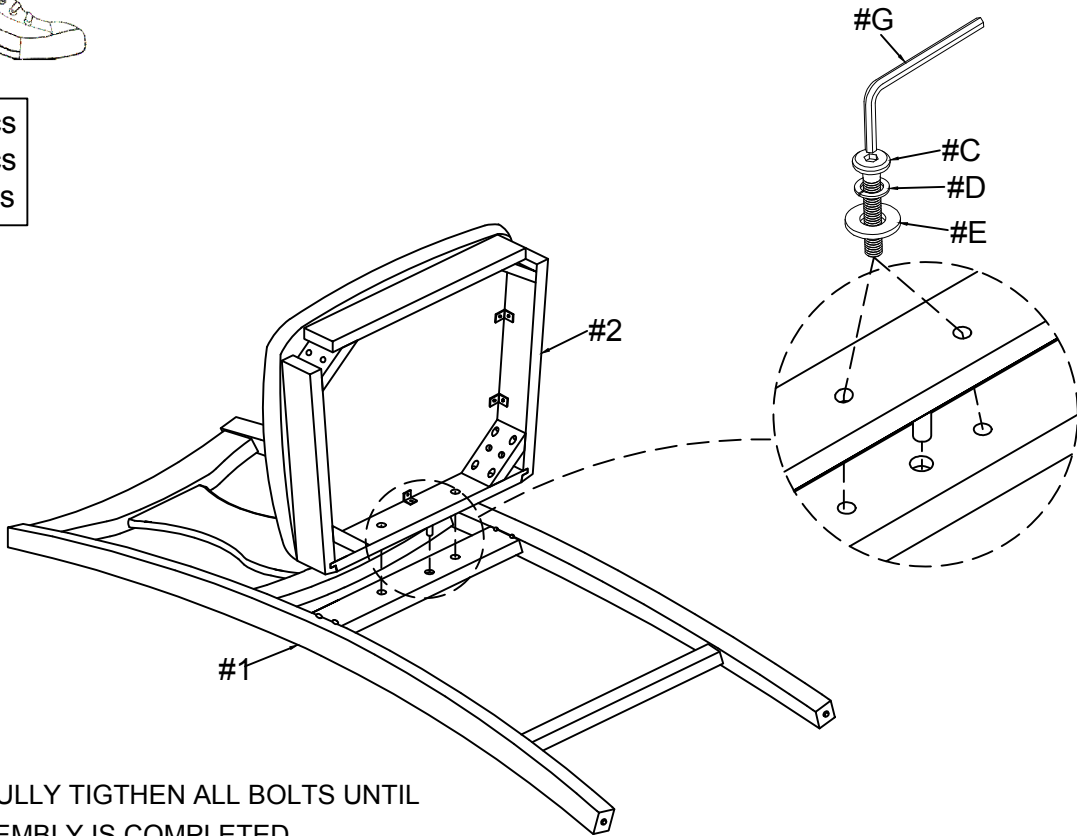

DO NOT FULLY TIGHTEN ALL BOLTS UNTIL FULL ASSEMBLY IS COMPLETED.



Secure corner holes of the seat (#2) to chair back (#1) by using bolts (#A) with washers (#D,E).

- #A x 4pcs
- #D x 4pcs
- #E x 4pcs

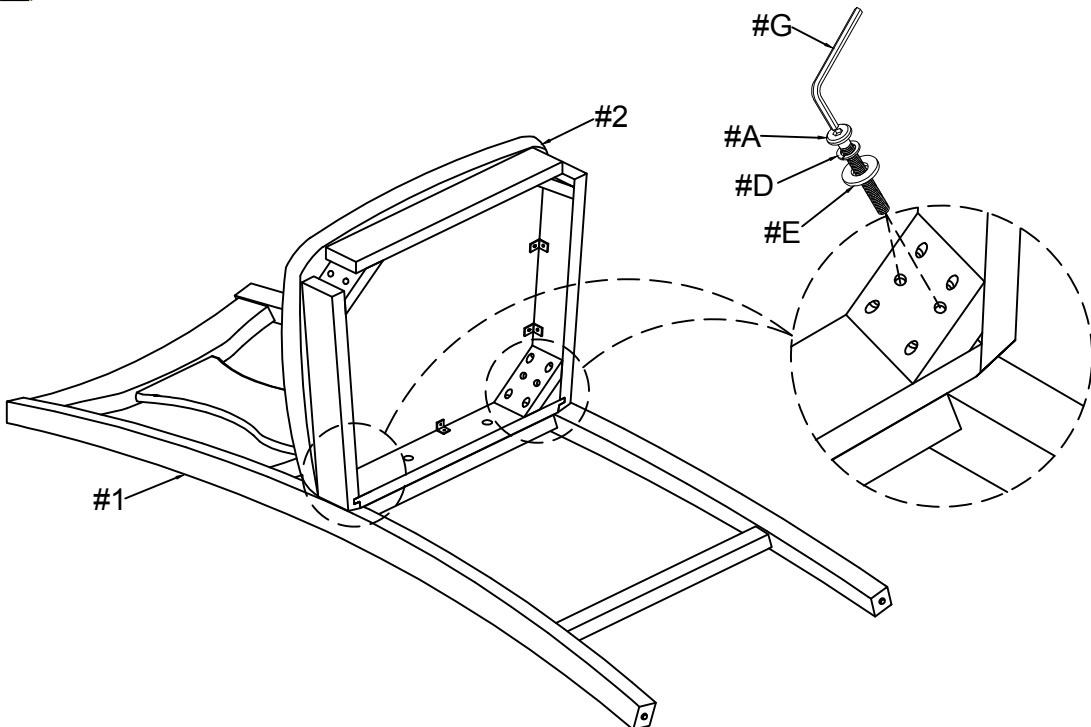



Align front legs (#3R/L) to seat (#2), then secure by using bolts (#B) with washers (#D,E).  
Make sure front legs (#3R/L) are loose, then align stretchers (#4R/L,5) to legs.

#B x 4pcs  
#D x 4pcs  
#E x 4pcs

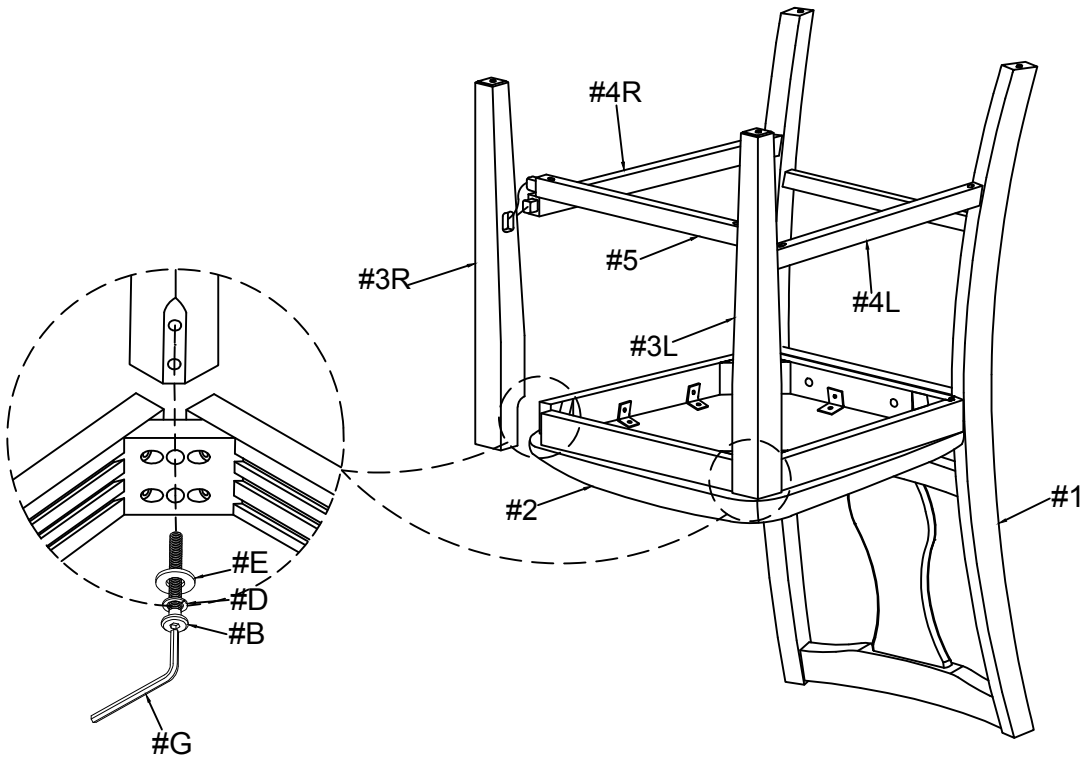

Secure stretchers (#4R/L,5) by using screws (#F).

#F x 6pcs

