

# Assembly Instructions

## CLUB CHAIR

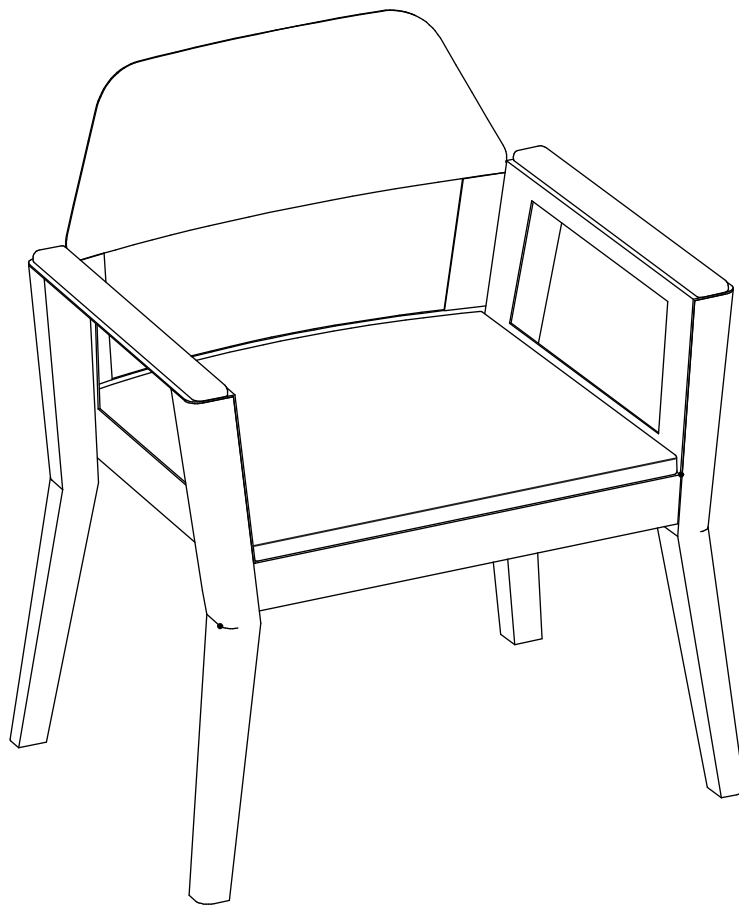

CAUTION: You must read this before you proceed.

Please look in the Seat Frame for hardware packs





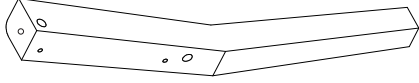
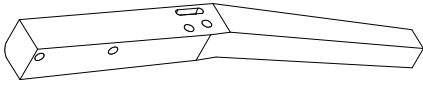

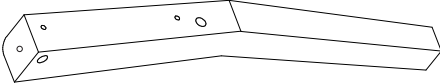
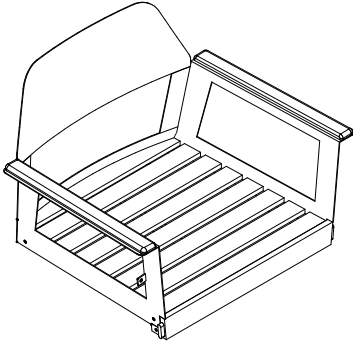
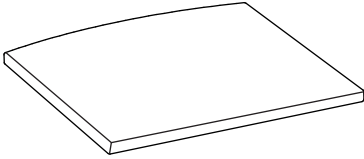
**CAUTION:** This Chair is NOT a TOY.  
Keep your child/children at bay during the assembly process.  
Whenever lifting the Chair and to prevent damage to the Chair two adults are needed to execute this action.

## Parts List

No.	Picture	Description	Qty
A	 A 3D perspective drawing of a single, L-shaped wooden leg. It has a wider base and tapers towards the top. There are two small circular holes on the top surface of the shorter leg.	Back Right Leg	1
B	 A 3D perspective drawing of a single, L-shaped wooden leg, similar to part A but oriented for the front right. It has two small circular holes on the top surface of the shorter leg.	Front Right Leg	1
C	 A 3D perspective drawing of a single, L-shaped wooden leg, similar to part A but oriented for the front left. It has two small circular holes on the top surface of the shorter leg.	Front Left Leg	1
D	 A 3D perspective drawing of a single, L-shaped wooden leg, similar to part A but oriented for the back left. It has two small circular holes on the top surface of the shorter leg.	Back Left Leg	1
E	 A 3D perspective drawing of a complete seat frame. It features a curved backrest, two armrests, and a seat base made of several parallel wooden slats. The frame is shown without any upholstery.	Seat Frame	1
F	 A 3D perspective drawing of a rectangular seat cushion with a slightly curved top surface and a thin, raised edge.	Seat Cushion	1

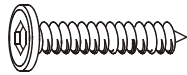
# Hardware

## Chair Hardware

No.	Picture	Description	Qty
①		Bolt M6 x 40mm	9
②		Bolt M6 x 60mm	5
③		Washer (6/16 x 2mm)	13
④		Allen Key	1

## Assembly Preparation

### Before Beginning Assembly:

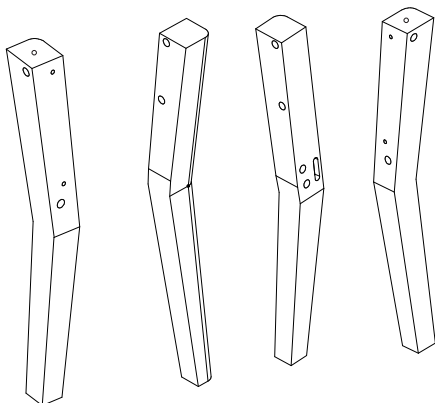
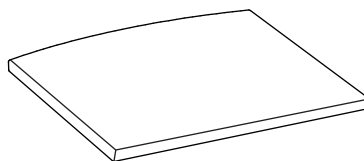
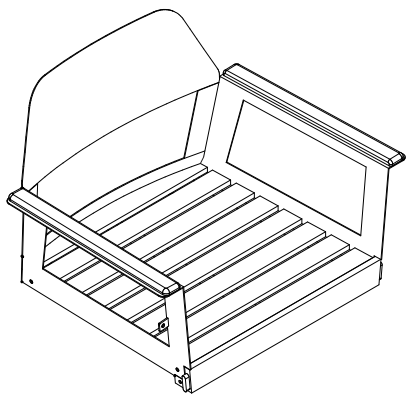

Read instructions, cover to cover.



Have 2 adults on hand for assembly.



Do not assemble on flooring or carpet.



Assemble on a clean non-marring surface (packing foam).



Save all packaging until finished.

## Assembly Steps

### OVERVIEW

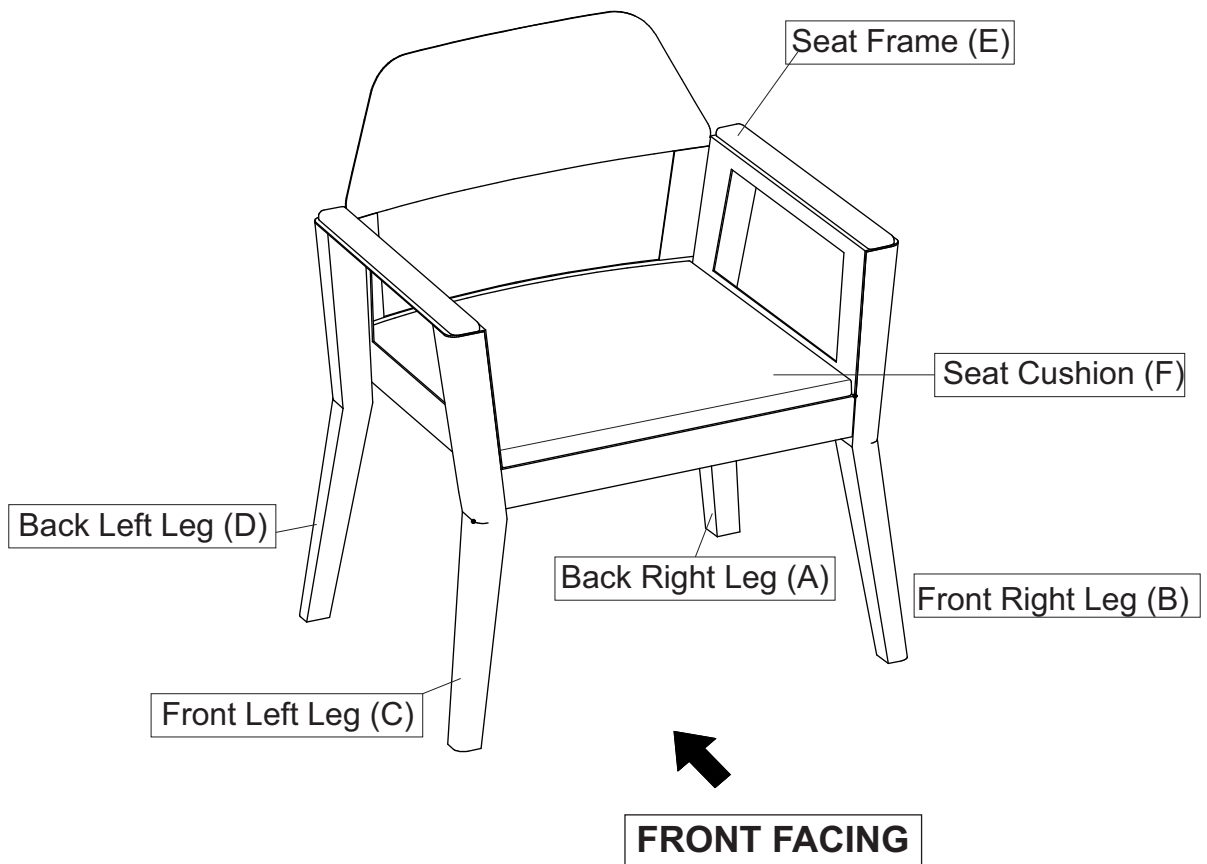

This Chair has multiple parts and may require up to 30 minutes to assemble. To give you an overview of the Chair parts, the above picture is to help you put the various parts into perspective. Please read through the instructions below to familiarise yourself with the parts and steps before assembly.

### **Step 1**

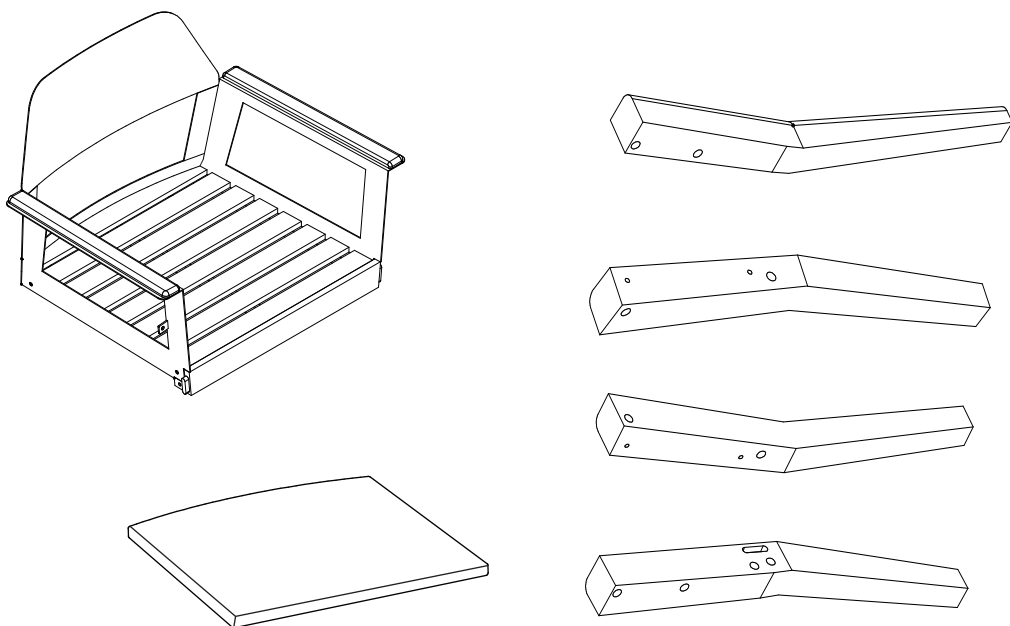

Unpack and place all parts on a clean, non-marring surface.

## Assembly Steps

### Step 2

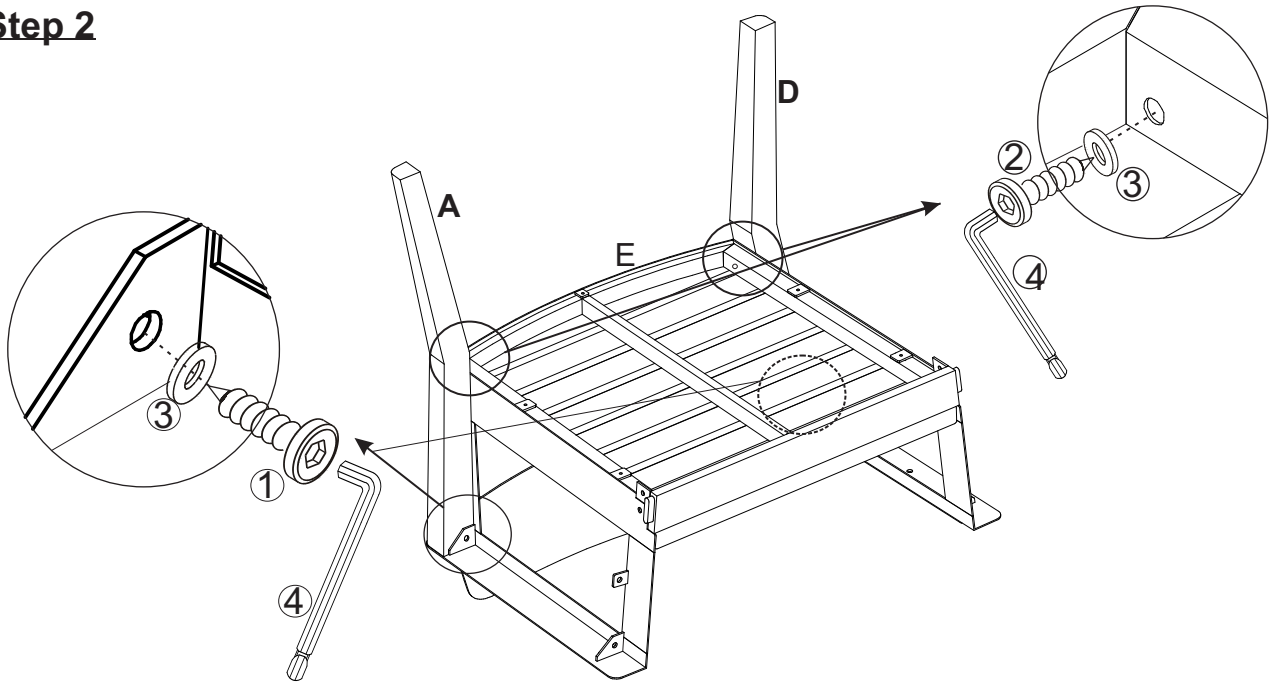

Place the Seat Frame (E) facedown on a clean, non-marring surface as shown in above picture. Attach the Back Right Leg (A) and Back Left Leg (D) to the Seat Frame (E) by using Screw (1), Screws (2), Washers (3) and Allen Key (4).  
**Do not fully tighten the Screws.**

### Step 3

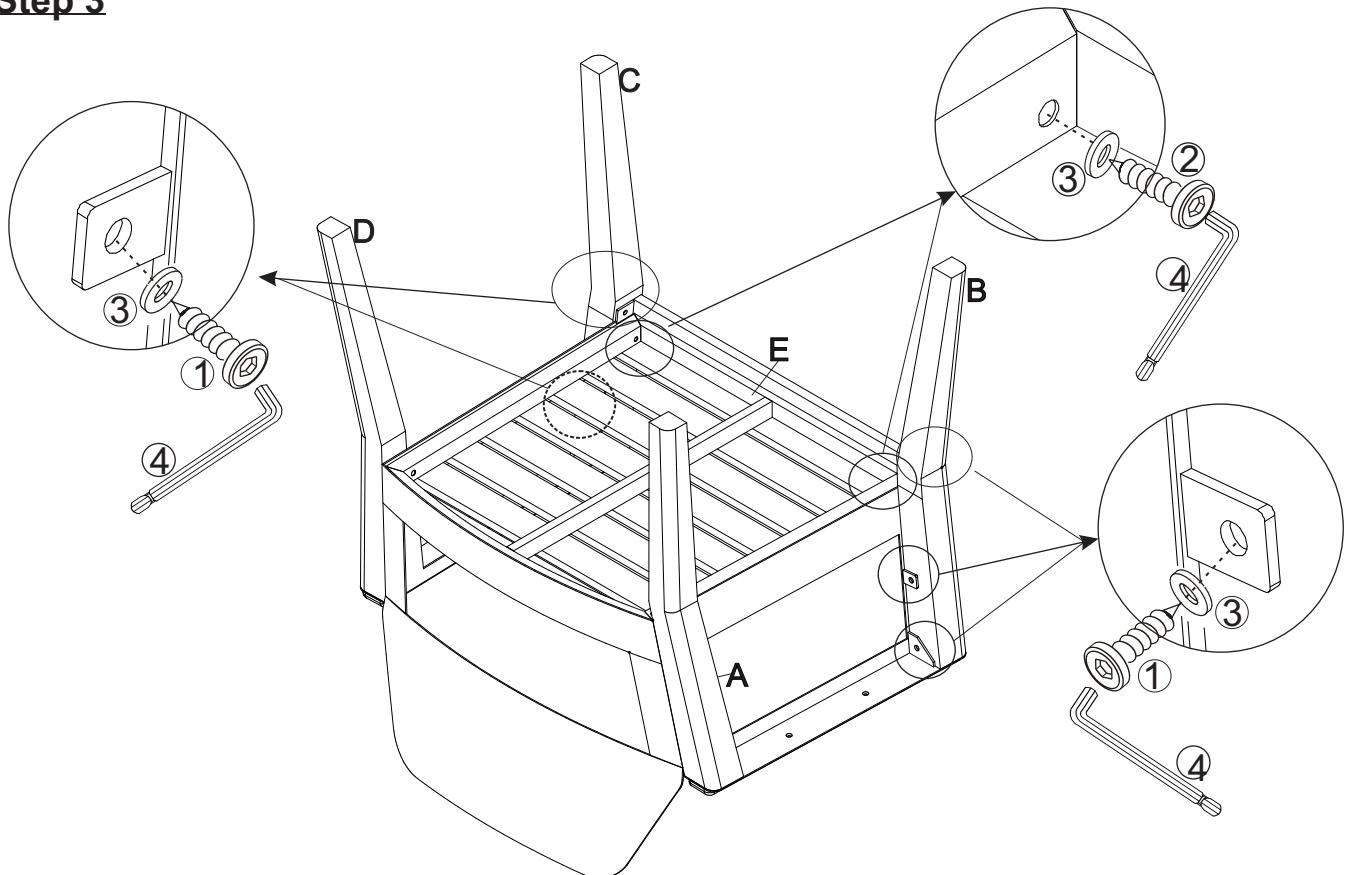

Attach the Front Right Leg (B) and Front Left Leg (C) to the Seat Frame (E) using Screws (1), Screws (2), Washer (3) and Allen Key (4).  
**Do not fully tighten the Screws.**

## Assembly Steps

### Step 4

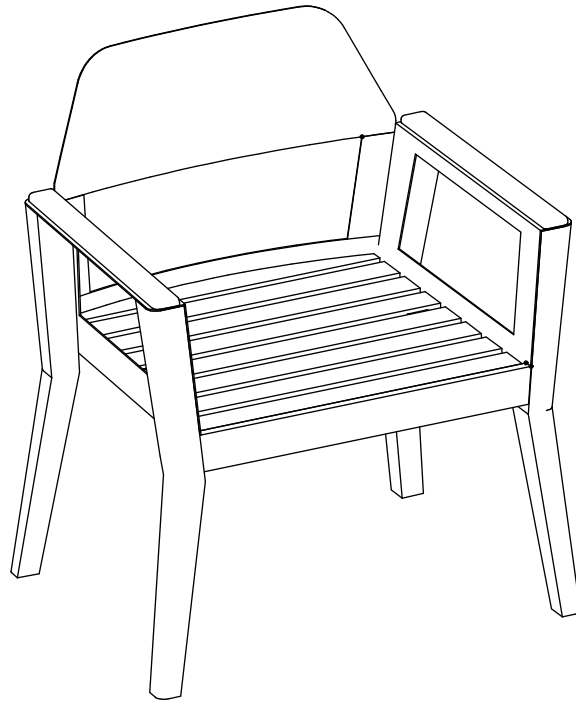





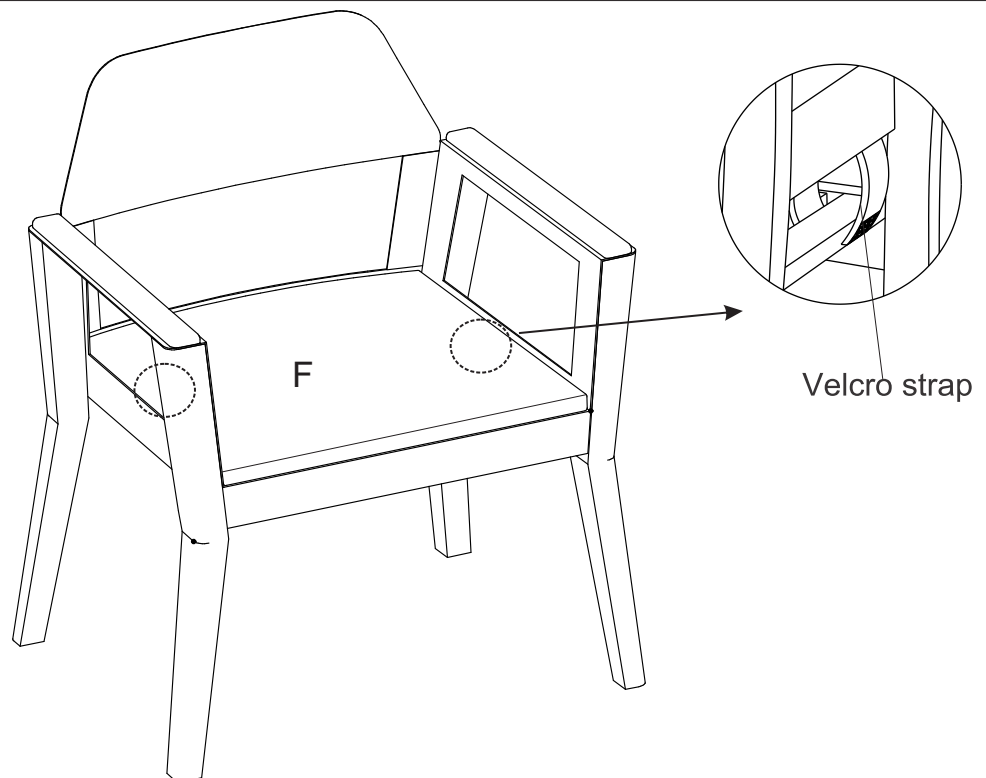













With the assistance from your adult partner, turn the Chair right side up. Exert pressure floorwards, onto the Chair with both your hands. This pressure will help the Legs and Chair reach full alignment status. Check for wobbles on a LEVEL surface. If no wobbles are found proceed to tighten Bolts in a sequential manner, until evenly secured. When tightening Bolts tighten sequentially. Do not tighten any Bolt fully and then move on towards the next one. If there are still wobbles, loosen Bolts and execute the same above process.

### Step 5



Put Seat Cushion (F) onto the Chair.  
Tie the velcro straps of Seat Cushion(F) to the slats of Seat Frame (E).  
Your Chair is ready for use.  
This Chair can only be used on a flat, level surface.

## Care & Maintenance

-   ● Do not put hot items directly on furniture surface
-   ● Do not clean furniture with harsh cleansers or polish.
-   ● To obtain the longest lifespan of your outdoor products, minimizing exposure to direct sunlight is recommended.
-   ● Children should not climb or jump on the furniture.
-   ● Do not write on furniture without a padded barrier to protect the surface.
-   ● To obtain the longest lifespan of your outdoor products, avoid extended and lengthy exposure to rain, snow, and direct sunshine. Whenever possible cover the product and /or place under patio or awnings.
-   ● Not for commercial use. For residential use only .
-   ● Stains may be removed with mild soap solution and damp cloth.
-   ● Dust and pick-up spills using a clean, non-colored, lint-free cloth.