

Pakroman
NorthAmerica Inc



PAKROMAN

PRODUCT MODEL:



CONTACT INFORMATION

Contact mail:

info@pakroman.com

Contacts:Johnson

Working hours:

8:30am-5:30pm (Pacific Time)

Toll Free:

877-834-4218

INSTALLATION ON OPERATION AND CARE MANUAL

Thank you for selecting the ice machine(s) from our company the dependability leader in ice making equipment & related products. With proper installation ,operation and maintenance your new ice machine(s) will provide you with more reliable & economical performance.

CONTENTS

The design of this modular ice cuber is the result of years of experience and testing. Standard features include front of accessible indicator lights and on-off switches that provide the user with fast access to critical information and easy operational control.

This installation and user manual is divided into three main sections: Installation, it is provided to trade person with the information needed to set up and install the ice cube machine; Use and Operation, which provides the user with the information to use the product; and Maintenance.

IMPORTANT

This manual should be read carefully before the appliance is serviced. Read the warnings and guidelines contained in this manual carefully as they provide essential information for the continued safe use, service, and maintenance of the appliance. Retain this manual for any further needs. This information manual needs to keep it in a safety place.

This manual is for the following models of devices: TF350 / TF500

CONTENTS

Important Safety Information -----	3
I .Ice Maker Overview -----	5
A.Ice Maker Features-----	5
B.Ice Maker Dimension Figure and Exterior structure-----	5
II.Installation and Operating Instructions -----	6
A. Installation location-----	6
B.Split Machine Installation Diagram-----	7
C.Foot Installation And Foot Placement-----	8
D. Electricity Supply-----	8
E. Water Supply /Drained-----	9
F.Checks After Installation and Cleaning-----	10
III、 Cleaning、 Sanitation and Maintenance -----	12
A. Ice Maker Routine cleaning-----	12
B.Cleaning and Sanitizing-----	14
IV、 Use and Operation -----	17
A.Electrical schematic diagram-----	17
B. Ice Maker Work Steps-----	17
C.LCD Control Panel Operating Manual-----	18
V、 Maintenance -----	22
A.Ice maker Interior Structure Diagram-----	22
B.Routine Precautions-----	24
C.Fault Self-diagnosis-----	24
D.Out-of-service machine treatment-----	27
E.Accessories List-----	27
F.Before Calling For Service-----	32
VI、 After-sales contact -----	36

Receiving And Checking

Thank you for selecting our company's ice maker. In order to protect your legitimate rights and interests, please pay more attention to the following things when receiving and checking the machine:

1. The outer packing of the machine is intact.
2. Machine's model is consistent with your purchased.
3. The appearance of the machine is in good condition.
4. The attached parts are complete.
5. The internal components of the machine are in good condition.



In the process of transportation, due to improper stacking or handling, the lubricating oil in the compressor will flow into the refrigeration pipeline, resulting in a serious lack of oil for the compressor. Once the power is switched on, the compressor will be burned in a short time. Therefore, we strongly suggest that after the customer receives our machine, place **the machine at the up right position for a day**, so that the lubricating oil can flow back to the compressor, then install and use the machine.

Important Safety Information

Throughout this manual, notices appear to bring your attention to situations which could result in death, serious injury, or damage to the unit.

⚠️ WARNING Indicates a hazardous situation which could result in death or serious injury.

NOTICE Indicates a situation which could result in damage to the unit or property.

IMPORTANT Indicates important information about the use and care of the unit.

⚠️ WARNING

This appliance should be destined only to the use for which it has been expressly conceived. Any other use should be considered improper and therefore dangerous. The manufacturer cannot be held responsible for injury or damage resulting from improper, incorrect, and unreasonable use. Failure to install, operate, and maintain the appliance in accordance with this manual will adversely affect safety, performance, component life, and warranty coverage and may result in costly water damage.

To reduce the risk of death, electric shock, serious injury, or fire, follow basic precautions including the following:

- Component parts shall be replaced with like components and that servicing shall be done by factory authorized service personnel, so as to minimize the risk of possible ignition due to incorrect parts or improper service.

Important Safety Information

- The appliance must be installed in accordance with applicable national, state, and local codes and regulations.
- Electrical connection must be hard-wired and must meet national, state, and local electrical code requirements. Failure to meet these code requirements could result in death, electric shock, serious injury, fire, or damage to equipment.
- The icemaker requires an independent power supply of proper capacity. See the nameplate for electrical specifications. Failure to use an independent power supply of proper capacity can result in a tripped breaker, blown fuse, damage to existing wiring, or component failure. This could lead to heat generation or fire.
- THE ICEMAKER MUST BE GROUNDED.** Failure to properly ground the ice maker could result in death, serious injury, or damage to equipment. Set the control power point to
- Set the control power point to the "OFF" position and turn off the power supply before servicing. Lockout/Tag out to prevent the power supply from being turned back on inadvertently.
- To reduce the risk of electric shock, do not touch the control switch with damp hands.
- Do not make any alterations to the appliance. Alterations could result in electric shock, injury, fire, or damage to the appliance.
- This appliance is not intended for use by persons (including children) with reduced physical, sensory, or mental capabilities, or lack of experience and knowledge, unless they have been given supervision or instruction concerning use of the appliance by a person responsible for their safety.
- Children should be properly supervised around this appliance.
- Do not climb, stand, or hang on the appliance or allow children or animals to do so. Serious injury could occur or the appliance could be damaged.
- Do not climb, stand, or hang on the appliance or allow children or animals to do so. Serious injury could occur or the appliance could be damaged.
- Do not use combustible spray or place volatile or flammable substances near the appliance. They might catch fire.
- Keep the area around the appliance clean. Dirt, dust, or insects in the appliance could cause harm to individuals or damage to the appliance.

NOTICE

- Follow the water supply, drain connection, and maintenance instructions carefully to reduce the risk of costly water damage.
- In areas where water damage is a concern, install in a contained area with a floor drain.
- Install the ice maker in a location that stays above freezing. Normal operating ambient temperature must be within 45°F to 100°F (7°C to 38°C).
- Do not leave the ice maker on during extended periods of non-use, extended absences, or in sub-freezing temperatures. Please pay attention to water control and use professional packaging outside the ice maker.
- Do not place objects on top of the appliance.
- The ice storage bin is for ice use only. Do not store anything else in the ice storage bin.

I .Ice Maker Overview

I.Ice Maker Overview

- Split design .It can be used for large production with ice, and it is more convenient to clean.
- The main door panel does not need tools, directly open, convenient maintenance.
- The ice storage bucket door closed softly to avoid impact .
- Copper nickel ice sheet, quick ice making and short deicing time.
- Ice production by flowing water is more than 12% higher than that of similar machines.
- The high quality brand compressor reduces the noise of ice making by more than 5%.
- The inner gallbladder in the ice is made from PE food grade materials.
- High quality stainless steel and ABS engineering plastics.Beautiful and durable.
- Our company’s products have passed ISO9001、CE、SGS certificates.

A.Ice Maker Dimension Figure and Exterior structure

•Ice Maker Exterior structure

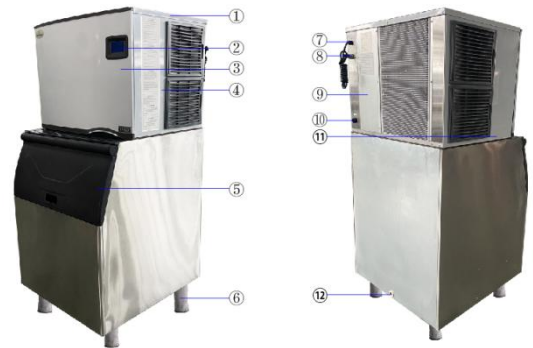
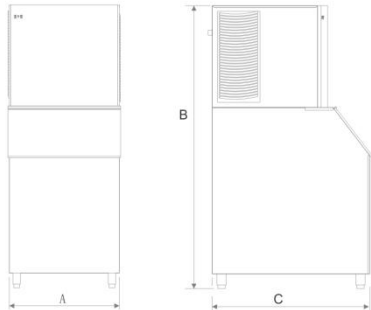

•Ice Maker Dimension Figure: (Unit: in)

	A	B	C
TF350	22	55.7*3.9	29.5
TF500	30.7	59.8*3.9	31.8

	MODLE
①	TOP PANEL
②	LCD
③	FRONT PANEL
④	SIDE PANEL(R)
⑤	ICE BUCKET DOOR
⑥	ADJUST FOOT
⑦	POWER CORD
⑧	INLET WATER VALVE
⑨	REAR PANEL
⑩	DRAIN VALVE
⑪	SIDE PANEL (L)
⑫	DRAIN PIPE INTERFACE

II.Installation Operating Instructions And Checks Before Installation

⚠ WARNING

1. Install in accordance with all applicable national, state, and local codes and regulations.
2. CHOKING HAZARD: Ensure all components, fasteners, and thumbscrews are securely in place after installation. Make sure that none have fallen into the storage bin.

A. Installation Location

- This ice maker is not suitable for outdoor use, and its installation location should not be close to heat source or direct sunlight;
- The normal operating ambient temperature must be 45 ° F to 100 ° F (7 ° C to 38 ° C). If the ice maker works beyond the above normal temperature range for a long time, the ice making capacity may be affected;
- The ice maker shall be installed on a solid and flat ground;
- The ice maker shall be placed close to the drinking water source, and it is recommended to be within one meter from the ice maker;
- Do not block the ventilation window of the ice maker. There should be enough air convection space around the ice maker, with an interval of 30cm or more;
- Install the ice maker above zero. The normal operating ambient temperature must be between 45 ° F and 100 ° F (7 ° C and 38 ° C).
- The ice maker cannot operate at temperatures below zero., To prevent water supply pipeline failure, please drain the water in the ice maker when the temperature is lower than zero (see "Preparations for long-term storage of the ice maker").

⚠ WARNING

The ice maker is to be installed in accordance with the Safety Standard for Refrigeration Systems, ASHRAE 15, the ice maker shall not be installed in corridors or hallways of public buildings.

NOTICE

Maximum daily ice volume test conditions:The ambient temperature is 69.8 ° F(21 ° C), and the water temperature is 50 ° F(10 ° C).

B.Split Machine Installation Diagram

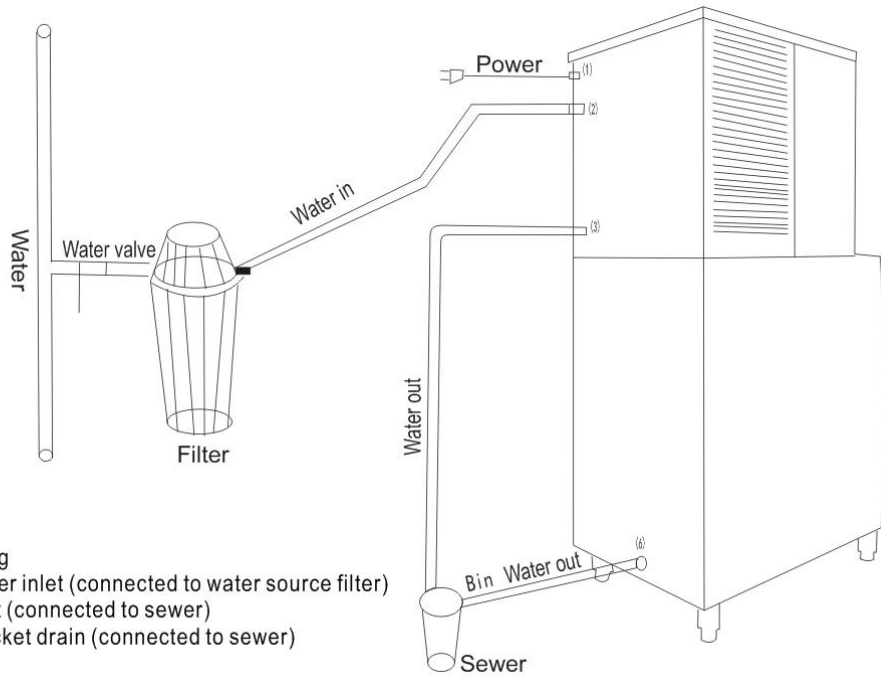

1. Power cord plug
2. Ice making water inlet (connected to water source filter)
3. Ice water outlet (connected to sewer)
4. Ice storage bucket drain (connected to sewer)

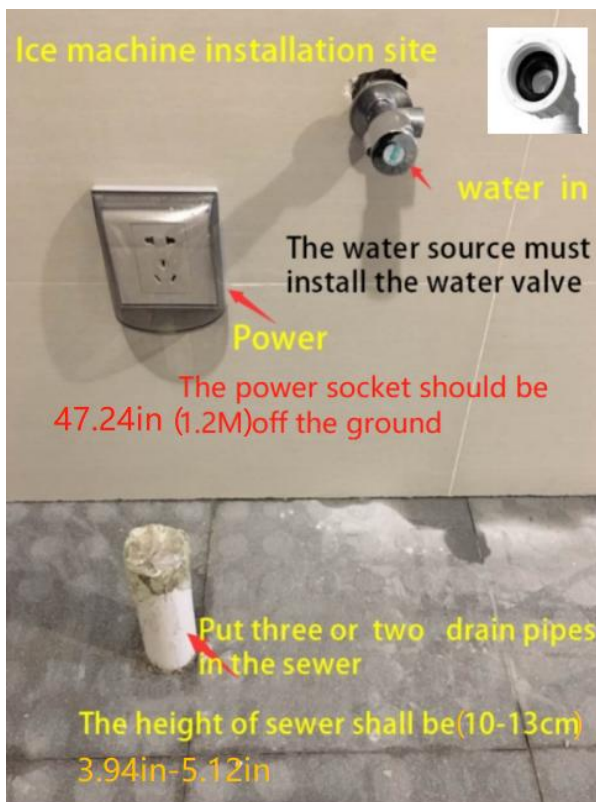

1. The machine at the up right position for a day
2. Inlet water pressure: 1.8pa
3. The water pipe is 25mm connection OD

II .Installation and Operating Instructions

C.Foot Installation And Foot Placement

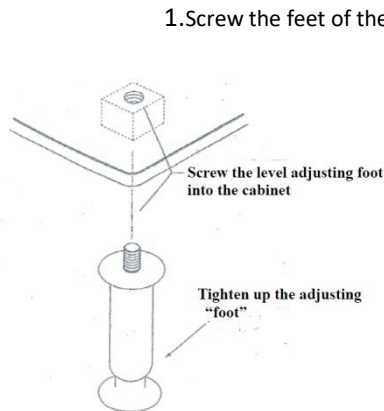

- 1.Screw the feet of the ice maker to the base plate.
- 2.Each foot must be screwed up and tightened so as not to bend.
- 3.Put the ice storage bucket in a solid and flat position.
- 4.Move the ice maker to the installation position.
- 5.Level the ice bucket to ensure that the door of the refrigerator is closed and sealed properly.Place a level ruler on the top of the box, Adjust the feet to level the Ice storage bucket.
- 6.Level the ice maker and storage bin in both the left-to-right and front-to-rear directions.Adjust the storage bin legs to make the Ice maker level.
- 7.Place the top on the ice storage bucket.
- 8.Ice making machine should not be installed in the environment without sewer and water seepage,and it is strictly prohibited from high temperature equipment.
- 9.Air-cooled ice making machines(such as refrigerators,ovens,etc.)rely on air circulation to dissipate heat.**So it all around necessary to keep the space above 11 7/8in (30CM) to benefit the heat dissipation.**

NOTICE

The normal operating ambient temperature must be 45 ° F to 100 ° F (7 ° C to 38 ° C).
Maximum daily ice volume test conditions:The ambient temperature is 69.8 ° F(21 ° C),
and the water temperature is 50 ° F(10 ° C).High temperature will seriously reduce the
amount of ice production. We suggest that the client put the ice maker in a place with
good air Ventilation.

D. Electricity Supply

⚠ WARNING

1. Electrical connection must be made in accordance with the instructions on the "WARNING" tag, provided with the pig tail leads in the junction box.
2. Electrical connection must be hard-wired and must meet national, state, and local electrical code requirements. Failure to meet these code requirements could result in death, electric shock, serious injury, fire, or severe damage to equipment.
3. This unit requires an independent power supply. See the nameplate for proper voltage and breaker/fuse size. Failure to use a proper breaker or fuse can result in a tripped breaker, blown fuse, or damage to existing wiring. This could lead to heat generation or fire.
- 4.**THE ICEMAKER MUST BE GROUNDED.** Failure to properly ground the ice maker could be result in death or serious injury.

II .Installation and Operating Instructions

- The voltage, frequency and capacity of the power supply shall be consistent with those marked on the nameplate of the machine;**110V**
- When starting up(the load of the electric circuit is the maximum),the maximum allowable range of voltage is $\pm 10\%$ of the rated voltage.The ice machine must be well grounded.

E.Water Supply and Drain Connections-See Fig.

WARNING

Water supply and drain connections must be installed in accordance with applicable national, state, and local regulations.

NOTICE

1. Normal operating water temperature should be within 45° F to 90° F(7° C to 32° C).Operation of the ice maker, for extended periods, outside of this normal temperature range may affect ice maker performance.
- 2.To prevent damage to equipment, do not operate the ice maker when the water supply is off, Or when the water pressure is low . Do not run the ice maker until the proper water pressure is reached.

The flexible wire of power supply

In case of any further danger, if the wire was broken, only the professionals of the manufacturing plant or maintenance department could do the renewing work.

Water supply/Drain Requirements

Water supply

Local water conditions many require treatment of the water to inhibit seale formation, filter sediment & remove.

Water inlet Line Attention:take pipe should be connected with the source of drinkable water.

Follow the requirements below to install water inlet lines:

- Don't connect the ice machine to a hot water supply.
- If the water pressure exceeds the maximum recommended 1.7 pa,obtain a water pressure regulator from your distributor.
- A water cut-off valve must be installed in the front of the in-take pipe of the ice machine.
- External filters,strainers,or softeners may be required depending on water quality.Contact your local Certified Service Representative for recommendations.

WARNING

**Ice machines must be connected to drinkable water, our company
The single-stage filters provided do not meet the drinking water
standards. Please purchase and replace it.**

II .Installation and Operating Instructions

Installation of water drainage pipe

When erecting water drainage pipe, measures should be taken to prevent the drained water from flowing back into the ice machine or the ice storage bin. Please follow the guidance below:

- Drain lines must have a 0.98 In per meter of run & must hit create traps.
- The final drainage exit must be large enough drain all the water from all drains.

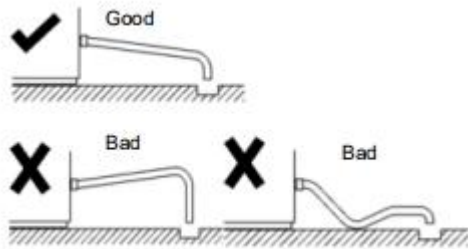

Note:

The installation of intake and drainage pipeline must comply with relevant local laws and regulations. In some situations, the pipeline may require to be installed by a qualified plumber.

F. Checks After Installation and Cleaning

- Cleaning after Installation: After the ice maker is installed, Clean the ice machine shell and ice storage bucket with a clean wet foam cloth/sponge.

⚠ WARNING

Prohibition of use: lacquer thinner; oxalic acid, hydrochloric, Detergents containing alcohol and other corrosive liquids.

1. Is the ice maker installed indoors and the indoor temperature even in winter no lower than 10°C (50°F)?
2. Is there at least 30cm (12 inches) of clear space around the ice maker for ventilation and heat dissipation?
3. Is the ice maker adjusted to be level?
4. Have all electric wires and water pipes been well connected and the water valve on the intake pipe been opened?

II .Installation and Operating Instructions

5. Have supply voltage been examined and tested and does it comply with that marked on the nameplate of ice maker?
6. Have the inlet water pressure been examined and is it no lower than 1kg/cm² (1bar)?
7. Have all refrigeration pipes been properly protected from vibration or damage?
8. Have ice-store tank and ice maker been cleaned up?
9. Does the owner or user have a operation manual? Has he/she received correct training for regular maintenance and inspection?
10. Has the owner or user had the contact method and number of repair dealer's personnel?
11. Are all required kits and adapters properly installed?

WARNING

1. All parts are factory-adjusted. Improper adjustments may adversely affect safety, performance, component life, and warranty coverage.
2. Do not put your hands into the back of the storage bin or the baffle on top of the storage bin. Ice may drop off the ice maker, a hard block of ice may suddenly break down, or the ice making mechanism may suddenly move, resulting in injury.

NOTICE

1. If the unit is turned off, wait for at least 3 minutes before restarting the ice maker to prevent damage to the compressor.
2. To prevent damage to the water pump, do not leave the control switch in the "WASH" position for extended periods of time when the water tank is empty.
3. At startup, confirm that all internal and external connections are free of leaks.

III、 Cleaning、 Sanitation and Maintenance

A. Ice Maker Routine cleaning

⚠ WARNING

1. To prevent injury to individuals and damage to the ice maker, do not use ammonia type cleaners. Prohibition of use: Banana water, oxalic acid, hydrochloric, Detergents containing alcohol and other corrosive liquids.
2. Carefully follow any instructions provided with the bottles of cleaning and sanitizing solution.
3. Always wear liquid-proof gloves and goggles to prevent the cleaning and sanitizing solutions from coming into contact with skin or eyes.
4. During operation, the power supply of the ice maker must be disconnected.

NOTICE

To prevent damage to the water pump, do not leave the control switch in the "WASH" position for extended periods of time when the water tank is empty.

Environment cleaning: Clean the surroundings of the ice maker frequently to keep the environment clean and make the equipment operate efficiently.

Shell cleaning: Clean the ice maker with a sponge dipped in neutral detergent, and dry it with a clean soft cloth.



Cleaning of air filter screen: The filter screen can filter dirt or dust in the air to prevent the condenser from being blocked. If the filter screen is clogged, the performance of the ice maker will decline. It is recommended to clean the air filter screen once or twice a month: remove the air filter screen; Clean the air filter screen with a vacuum cleaner or soft brush. If the air filter screen is seriously blocked, warm water and neutral detergent can be used for cleaning; Wait until the air filter is completely dry, Then replace it in its original position.



NOTICE

Do not use hot water, thinner, or any cleaning agent to clean the air filter screen

Condenser cleaning: It is recommended to clean the condenser every six months, and the following steps should be followed: Use a soft brush or a vacuum cleaner with a brush to clean the outside of the condenser, which should be moved from the top to the bottom. (Moving the cleaning soft brush from one side to the other will deform the condenser fins); Use a commercially available coil (air conditioning) cleaner. Follow the instructions and precautions of coil cleaner when using. Damaged fins shall be combed with fin comb.

Blade and fan motor cleaning: Carefully wipe the fan blade and motor with a soft cloth, and do not bend the fan blade. If the fan blade is too dirty, it can be cleaned with warm soapy water, and then rinsed thoroughly. Brush the dust on the condenser fins along the direction of the fins with a nylon brush.

⚠ WARNING

Clean the condenser, disconnect the power supply of the ice maker.
The condenser has sharp edges, Be careful to cut when cleaning.
Cover the fan motor to prevent water.

IMPORTANT

The condenser if dirty, which will block the air flow and cause the ice maker to operate at the over heating situation , the ice making capacity will be reduced and the service life of parts will be life shortened

III、 Cleaning、 Sanitation and Maintenance

Blade and fan motor cleaning: Carefully wipe the fan blade and motor with a soft cloth, and do not bend the fan blade. If the fan blade is too dirty, it can be cleaned with warm soapy water, and then rinsed thoroughly.

Filter screen cleaning: the filter screen is drawn out from both sides, and the dust on the filter screen is removed with a brush.



Cleaning and Sanitizing

In order to ensure stable and efficient operation of the ice maker, the user is responsible for operating according to the requirements of cleaning and disinfection (cleaning and disinfection operations are not included in the warranty terms). If the ice maker needs to be cleaned and disinfected frequently, please check whether the water source and use environment are clean, whether there is a filter or whether the filter used can meet the filtering requirements of the ice maker.

⚠ WARNING

1. To prevent injury to individuals and damage to the ice maker, do not use ammonia type cleaners. Prohibition of use: Banana water, oxalic acid, hydrochloric, Detergents containing alcohol and other corrosive liquids.
2. Carefully follow any instructions provided with the bottles of cleaning and sanitizing solution.
3. Always wear liquid-proof gloves and goggles to prevent the cleaning and sanitizing solutions from coming into contact with skin or eyes.
4. During operation, the power supply of the ice maker must be disconnected.

NOTICE

1. Do not use sharp objects to clean the evaporator
2. It is recommended to perform this operation at least once within 3 months

Cleaning process

1. Open the ice maker door and check whether the evaporator of the ice maker is making ice. If ice making is in progress, press the ice making key to stop ice making, wait for the ice to melt naturally (ice is thin) or wait for the end of the deicing procedure, and then press the ice making key to stop the ice maker.

III、 Cleaning、 Sanitation and Maintenance

- **Cleaning of ice bucket:** take out all ice cubes in the refrigerator with an ice shovel.

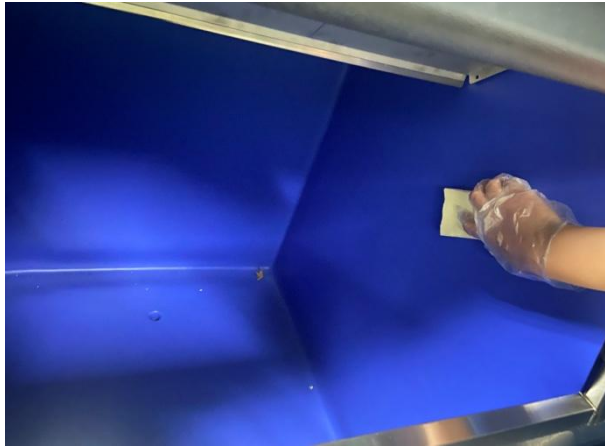

- **Cleaning of water pump and float ball:** press the [About] key to be in standby mode, the screen will display "OFF", unplug the power plug, remove two screws on the water pump hanging plate and two screws on the float ball with a screwdriver, remove the clamp, and remove the connector at the water supply pipe, water pump and float ball to remove the water pump and float ball for cleaning;



- **Sink cleaning:** wipe the sink with a soft cloth



- Turn off the power supply of the ice maker, remove the water tank, water pipe, and water deflector, take out the ice shovel, and mix 8 liters of warm water 113° F ~ 122° F (45~50 °C) and 2 packets of cleaning agent into a cleaning solution (the amount of cleaning solution needs to be adjusted appropriately).

III、 Cleaning、 Sanitation and Maintenance

●Soak the parts in the cleaning solution for more than 5 minutes (it is recommended to soak for more than 10 minutes in case of heavy scale). After soaking, wear rubber gloves and carefully clean all parts with a soft nylon brush, sponge or soft cloth. While soaking the parts, use a nylon brush or a soft cloth dipped in cleaning solution to wipe the surfaces of parts and components that are in contact with water and ice, such as the inner surface of the ice maker, the door, the ice lattice of the evaporator, the top, bottom, and side plastic parts (the dead corners can be cleaned by wrapping chopsticks with a wet rag dipped in cleaning agent), and after 20 minutes, clean them with cleaning agent. Take out the soaked parts and rinse them with clean water. Install the removed parts back to the original position

Rinsing process

1. Wipe the internal and external surfaces of the equipment with a clean wet rag/sponge to remove disinfectant residues.
2. Then rinse the inner surface of the refrigerator, the plastic parts of the evaporator and the parts of the sink with clean water.
3. Drain all water after flushing.
4. Install all parts back on the ice maker.
5. Press the [Ice making] icon to start the ice maker.
6. Discard the first five plates of ice to ensure that the disinfectant is completely discharged from the system.
7. Turn off the power to return the ice maker to its original position and complete the cleaning and disinfection process.

●Filter element should be checked regularly. The ordinary filter element should be replaced once every 1-2 months, and the advanced filter element should be replaced on time according to the instructions.

WARNING

Routine cleaning and disinfection of any ice maker,
Not within the manufacturer's scope of repair

WARNING

If the scale of the ice maker is serious or the
water channel is blocked, please operate according
to the instructions or call the dealer's service
phone. There are charges for door-to-door service

WARNING

Before cleaning and disinfection, be sure to turn off the
water source and power supply, Pull off plug.

WARNING

The edges of condenser fins are sharp, please
be careful when cleaning.

WARNING

Filter element must be replaced regular

IV、 Use and Operation

A. Electrical schematic diagram

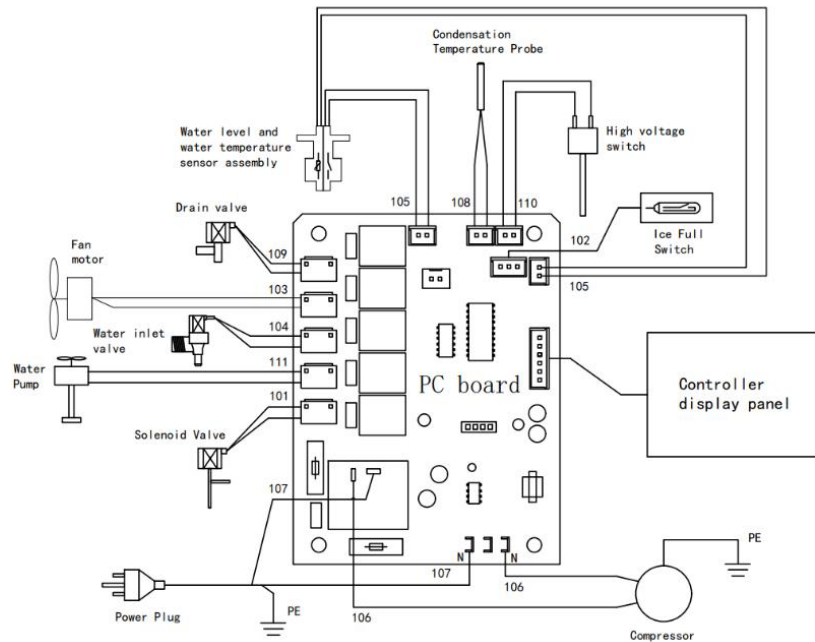

101	Solenoid Valve
102	Ice Full Switch
103	Fan motor
104	Water inlet valve
105	Water level and water temperature sensor assembly
106	Compressor
107	Power Plug
108	Condensation Temperature Probe
109	Drain valve
110	High voltage switch
111	Water Pump
	Controller display panel

B. Ice Maker Work Steps

The working steps of the ice maker are divided into three parts:

1. The ice maker enters water for 30 seconds, the compressor starts, defrosts, starts the 2-minute automatic circulation program, the water tank continuously enters water, and the water pump runs. You can hear the sound of the water pump flowing from the top of the shunt pipe to the water tank. After ensuring that the ice maker is normal, start the ice making program and start ice making.

IV、 Use and Operation

2. Ice maker (cycle operation, maximum 40 minutes)

After the automatic detection is completed, the water pump starts after a delay of 45 seconds, and then starts ice making. During ice making, water pumped flows from the top of the ice lattice to the sink, and keeps circulating. The water slowly cools until it freezes. During ice making, PC control board program automatically senses the thickness of the ice. When the tested thickness is reached, it will go to the defrosting step.

3. Deicing (cycle operation, 4 minutes at most)

In the process of deicing, the ice will be defrosted and heated by the evaporator, and the connection between the ice and the ice lattice will be melted. When the ice cannot be attached to the ice lattice due to its weight, the ice will naturally fall off, completing a complete deicing process.

When the ice falls, the water deflector will automatically turn over, and then the water deflector will automatically return to its original position due to its weight, and it will automatically reach the ice making state again after recovery. When the ice in the ice bucket is full, it will touch the water deflector, and the water deflector cannot be reset. PC control board program automatically judges that the ice is full, and stops ice making until the ice in the ice bucket is removed. After the water deflector is reset, restart the ice maker again.

C.LCD Control Panel Operating Manual





General description: This is a fully automatic ice making machine, all programs of the LCD control panel have been set up in the factory. Usually, the user just need to do some simple operation. Please place the machine in the appropriate location and connect to power supplies.

NOTICE

Unplug the power supplies after finishing the day's work.

a.Button Description

There are five visible buttons under the control panel

Pictures	Name	FUNCTION
	On/Off button	Turn on/off the machine and set the program
	Model button	Adjust the running model
	Clean/Set button	Clean and set
	Schedule/+button	Increase the thickness of ice and the duty time.
	Light/-button	Reduce the thickness of ice and duty time,control the light.

b. Exact Description of Button Functions

On/Off button

1. In the startup state, press to turn off the ice maker.
2. When the power is off, press to start the ice maker.
3. In the time scheduling setting state, press this key to schedule time.
4. In the time plan status, press this key to shut down.

Clean/Set button

1. In the shutdown state, press the button. When the button flashes, release the button, and the machine will enter the manual cleaning state.
2. In the manual cleaning state, press the button, the machine will enter the liquid discharge step, and then enter the rinsing process. In the flushing state, press the button, the machine will enter the draining state and enter the next process.
3. Press the button to enter manual cleaning under the conditions of ice making, ice dropping and full ice.

Mode button

In the working state (precooling, ice making, deicing, etc.), the mode is switched.

Time/Plus button

1. When shutting down, press this key to enter the time schedule setting.
2. Under the schedule setting status, press briefly to increase 10 minutes, and long press to increase time continuously.
3. In the setting state, press briefly to increase a parameter, and press long to increase continuously.

e. Light/minus button

1. In the setting state, short press to decrease one of the parameters, and long press to continuously decrease.
2. Under the schedule setting status, short press will shorten 10 minutes, and long press will shorten continuously.
3. In the unset state, press this button to turn on/off the blue light.

f. LCD control panel status description (drawing description)

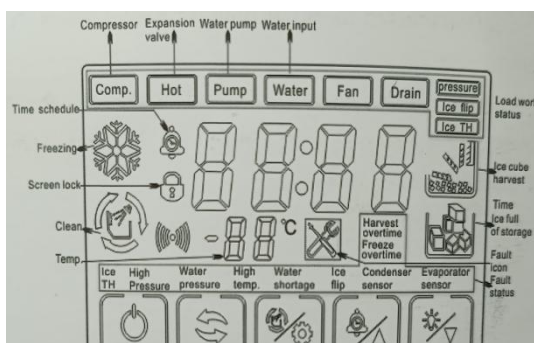

Show Status

1. **Power on:** LCD is fully lit, and the version number is displayed in four digits.
2. **Water inflow:** time display C00, ice making, deicing and full ice are on.

IV、 Use and Operation

3. **Pressure balance:** cleaning, ice making, deicing, Ice full light is on.
4. **Ice making:** The ice making icon is on, and the time is displayed as the ice making time.
5. **Deicing:** the deicing icon is on, and the time is displayed as the deicing time
6. **Full ice:** The icon of full ice is on, showing the time of full ice.
7. **Fault:** the fault icon flashes, and the corresponding fault Chinese characters light up.
8. **Shutdown:** OFF
9. **Appointment time setting:** the appointment icon is on, and the time is displayed as the reserved startup time.
10. **Reservation status:** The reservation icon flashes to display the countdown of the reservation time.
11. **Setting status:** the leftmost side of the time display screen is the setting parameter number, which is permanently lit. The following bit or 3 bits are parameter values, flashing.

g. Several frequently-used procedures setting for your reference. Please operate as the following steps when you need.

1. How to adjust the thickness of the ice?

Step1. Press any key on the bottom of display screen to unlock the system.



Step2. Press the up arrow key, the number will flashing for present thickness state.



Step3. Press the up or down arrow key to adjusting the thickness to your requested.



Step4. The ice machine will back to normal operation.

C.Splits type ice machine cleaning procedure

1. Starting to cleaning (make the water inlet connection is OK during the cleaning cycle)

2. Switch off the ice machine by press the power ON/OFF touch key on the display screen.

3. Make sure wear the safety gloves, the KAY-5 disinfecting powder needs be in the water tank and stir well.

20g for TF350;

28.4g for TF500

4. Press the cleaning key on the display screen.

5. Ice machine into the auto cleaning process, system in the cleaning process and the cleaning symbol is flashing on the left of display screen.

Auto cleaning procedure----20minets washing---1minet drainage---5minets washing---1minet Drainage---5minets washing---1minet drainage ---5minets washing---1minet drainage. Total of 39minets.

6. After the cleaning process, the ice machine back to normal operation state.

7. Press the ON/OFF power key on the display screen, the ice machine starting to work.

Note: after process of the cleaning, do not use the leftover ice in the ice storage bin and First three time of ice that was produced.



ON/OFF key

cleaning key



water channel



Cleaning icon

D.How to set the program when the ice storage is full?

When the ice storage is full, the control panel will display 'full ice' pattern as the following picture.



Step 1. Use ice shovel to clean the ices which cover on the ice chute board.

Step 2. Press the down arrow button to unlocked.

Step 3. Press **On/Off button** to turn off the machine, the control panel will appear '**OFF**'.

Step 4. Press **On/Off button** to turn on the machine, then press 3 times **Model button** to back to making ice model.

V、Maintenance

A.Ice maker Interior Structure Diagram

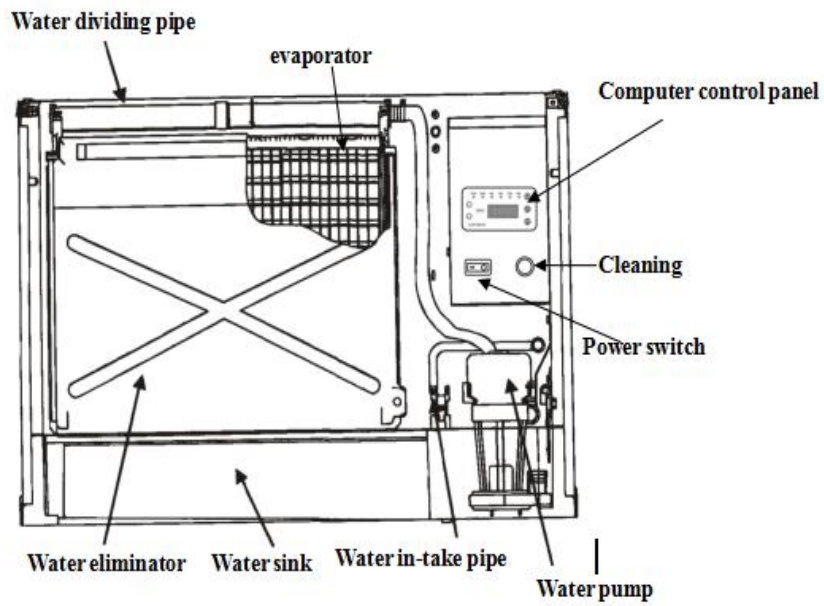
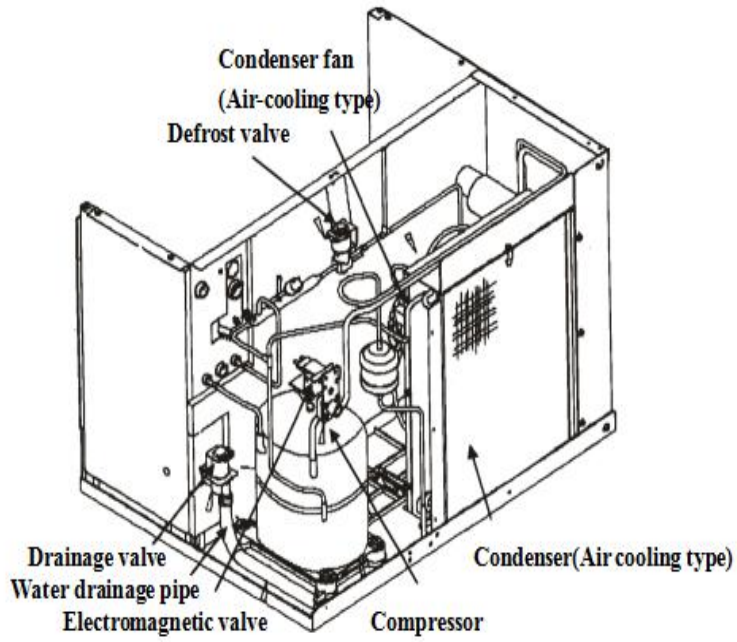

REFRIGERANT USED

- DANGER - RISK OF FIRE OR EXPLOSION. FLAMMABLE REFRIGERANT USED. DO NOT USE MECHANICAL DEVICES TO DEFROST REFRIGERATOR. DO NOT PUNCTURE REFRIGERANT TUBING.
- DANGER - RISQUE DE FEU OU D' EXPLOSION. LE FRIGORIGÈNE EST INFLAMMABLE. NE PAS UTILISER D' APPAREILS MÉCANIQUES POUR DÉGIVRER LE RÉFRIGÉRATEUR. NE PAS PERFORER LA TUBULURE CONTENANT LE FRIGORIGÈNE.
- DANGER - RISK OF FIRE OR EXPLOSION. FLAMMABLE REFRIGERANT USED. TO BE REPAIRED ONLY BY TRAINED SERVICE PERSONNEL. DO NOT PUNCTURE REFRIGERANT TUBING.
- DANGER - RISQUE DE FEU OU D' EXPLOSION. LE FRIGORIGÈNE EST INFLAMMABLE. CONFIER LES RÉPARATIONS À UN TECHNICIEN SPÉCIALISÉ. NE PAS PERFORER LA TUBULURE CONTENANT LE FRIGORIGÈNE.



Warning, Flammable Material

- CAUTION - RISK OF FIRE OR EXPLOSION. FLAMMABLE REFRIGERANT USED. CONSULT REPAIR MANUAL/OWNER'S GUIDE BEFORE ATTEMPTING TO SERVICE THIS PRODUCT. ALL SAFETY PRECAUTIONS MUST BE FOLLOWED.
- ATTENTION - RISQUE DE FEU OU D' EXPLOSION. LE FRIGORIGÈNE EST INFLAMMABLE. CONSULTER LE MANUEL DU PROPRIÉTAIRE/GUIDE DE RÉPARATION AVANT DE TENTER UNE RÉPARATION. TOUTES LES MESURES DE SÉCURITÉ DOIVENT ÊTRE RESPECTÉES.
- CAUTION - RISK OF FIRE OR EXPLOSION. DISPOSE OF PROPERLY IN ACCORDANCE WITH FEDERAL OR LOCAL REGULATIONS. FLAMMABLE REFRIGERANT USED.
- ATTENTION - RISQUE DE FEU OU D' EXPLOSION. ÉLIMINER CONFORMÉMENT AUX RÈGLEMENTS FÉDÉRAUX OU LOCAUX. LE FRIGORIGÈNE EST INFLAMMABLE.
- CAUTION - RISK OF FIRE OR EXPLOSION. DUE TO PUNCTURE OF REFRIGERANT TUBING; FOLLOW HANDLING INSTRUCTIONS CAREFULLY. FLAMMABLE REFRIGERANT USED.
- ATTENTION - RISQUE DE FEU OU D' EXPLOSION SI LA TUBULURE CONTENANT LE FRIGORIGÈNE EST PERFORÉE ; SUIVRE LES INSTRUCTIONS DE MANUTENTION AVEC SOIN. LE FRIGORIGÈNE EST INFLAMMABLE.

B. Routine Precautions

1. When transportation and mobile location, the ice machine tilt shall not exceed 45 degrees.
2. Ice machine, please use independent water source, and check regularly to prevent water pressure is too low, fluctuations or filter clogging.
3. Do not store any sundries in the ice storage room, or freeze any food in the ice storage room and keep the ice shovel clean.
4. Switch the ice storage bucket plastic door, should be light open and light closed, don't beat box door, after taking the ice, please turn off the sliding door of the ice storage bucket.
5. Ice machine should be far away from the heat source. It is strictly prohibited to use in high temperature or low temperature environment. It is necessary to avoid direct sunlight in order to avoid affecting the heat dissipation of the machine.
6. It is forbidden to wash the surface of ice machine directly with water, otherwise it may lead to short circuit, leakage and other faults.
7. After the ice machine is used for a period of time, if it is stopped for a long time, it should be electrified every two months for four to six hours.

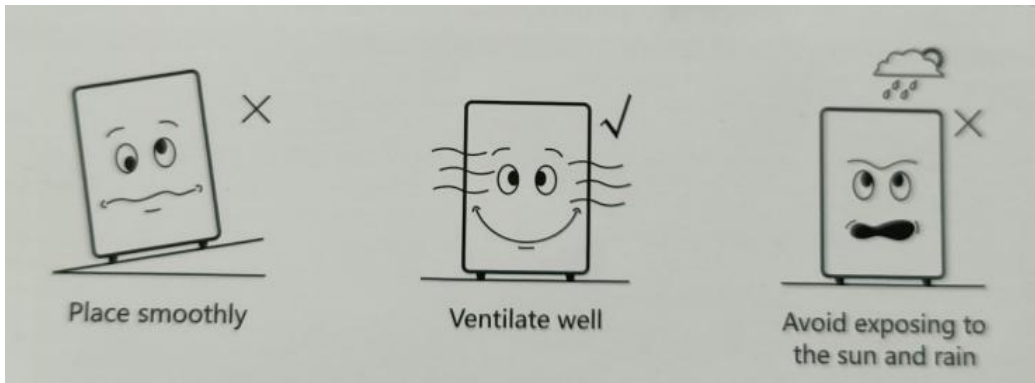

C. Fault Self-diagnosis

- 1) OFF: Power off.
- 2) C00: Power on & Water Ingress.
- 3) E01: Evaporator or Ice full switch Error, Automatic protection shutdown.
- 4) E02: Timeout Icing Error, protection shutdown.
- 5) E03: Timeout Deice Error, protection shutdown.
- 6) E04: High Temperature Error, protection shutdown.
- 7) E05: Lack of water Error, protection shutdown.
- 8) E06: High pressure over limit protection shutdown.
- 9) E07: Condenser sensor open circuit Error, Every 5 seconds showing 1 time without shutdown.
- 10) E08: Condenser sensor short circuit Error, Every 5 seconds display 1 time without shutdown.
- 11) E09: Evaporator sensor open circuit Error, display but without shutdown.
- 12) E10: Evaporator sensor short circuit Error, display but without shutdown.
- 13) E11: No refrigeration, protection shutdown.

V、Maintenance

Faults code SMG	Faults phenomenon	Causing	Check point	Repair service
E01	Water baffle (part code: 2210A15) or ice full switch (part code: 2210A24) fault	1、Water baffle (part code: 2210A15) out of position 2、ice full switch (part code: 2210A24) fault	Check and fixing	1.1、Check water baffle (part code: 2210A15) has installed. 1.2、Check water baffle (part code: 2210A15) has closed. 2、Check ice full switch (part code: 2210A24) wiring disconnected.
E02	Ice making time over setting limit of 10 times alarming	1、Ambient temperature high 2、No enough water	Check condenser (part code: 2210A03) or refrigeration system has leaking or shunt tube blocked; (part code: 2210A12)	1、Cleaning condenser or change cooling fan 2、re-start machine, machine will auto watering. 3、move the temperature sensor wire (part code: 2210A23)
E03	Deicing time over Limit for three Times alarming (alarm light on)	1、Deicing solenoid valve faulty. 2、Over condensing. 3、Ice thickness adjustment out of range. 4、No enough water.	Check solenoid valve or ice thickness sensor or water inlet system.	1、Check fan if faulty (part code: 2210A09). 2、Check if still making ice, Check ice thickness, if the Machine is not making ice, Re-start machine or contact us Immediately.
E04	High temperature alarming (alarm light on)	1、Ambient temperature too high. 2、Fan faulty 3、(part code: 2210A10) 4、Condenser dirty (part code: 2210A03)	Check related components	1、Check temperature sensor (part code: 2210A23) 2、Check fan (part code: 2210A10) 3、Cleaning condenser (part code: 2210A03)
E05	Lack of water (light on)	No water, low water pressure water inlet valve faulty (part code: 2210A18)、Water tank leaking water (part code: 2210A11)	Check related components	1、Toggle the float ball and Check the water tank if has water (part code: 2210A11)。Restart the machine. 2、Open the inlet water (part code: 2210A32), check the inlet Water valve (part code: 2210A18), contact us immediately if has no water

V、Maintenance

E06	The pressure over setting limit 2.5pa	1、 The condensing temperature too high 2、 The refrigeration system has blockage	Check refrigeration system pressure or cooling system	1、 Check fan (part code: 2210A09) or unit position if too close to the wall 2、 Contact us immediately.
E07	Condensing temperature sensor open circuit(part code: 2210A23)	Sensor faulty or Connection problems (part code: 2210A23)	Check related components	Removing the condensing temperature sensor and lets fan Keep running or contact us (part code: 2210A23).
E08	Condensing temperature sensor short circuit(part code: 2210A23)	Sensor (part code: 2210A23) Faulty or connection problem	Check related components	Removing the condensing temperature sensor and lets fan Keep running or contact us (part code: 2210A23).
E09	Open-circuit evaporation temperature sensor is faulty	sensor is damaged or the connector is faulty	Check related components	Unplug the temperature sensor and continue to use or contact us
E10	Evaporation temperature sensor short-circuited is faulty	sensor is damaged or the connector is faulty	Check related components	Unplug the temperature sensor and continue to use or contact us
E11	Refrigeration system not working as normal	1、 Condenser temperature sensor faulty (part code: 2210A23) 2、 Water pump not working (part code: 2210A16) 3、 Compressor not working (part code: 2210A01)or system leaking	Check related components	1、 Water pump (part code : 2210A16)if not working. 1.1、 Compressor (part code: 2210A01) running 1.2、 System leaking. 1.3、 Expansion valve (part code: 2210A20)faulty. 1.4、 Deicing solenoid valve leaking? (part code: 2210A22) 2、 Water pump (part code: 2210A16)not working. Contact us if above problems.

D.Out-of-service machine treatment

NOTICE



In an environment below 0 ° C, if water is left in the machine,
It may cause serious damage to the machine components,
The damage is not covered by the warranty.

If the ice maker is out of service for a long time or exposed to 0 ° C or below,
Special protective measures are required.

Follow these steps:

- Disconnect the power to the ice maker.
- Disconnect the water supply to the ice maker.
- Drain the water tank.
- Disconnect the water inlet pipe from the rear of the ice maker to drain the water in the water inlet pipe.
- Make sure that there is no water left in the inlet pipe, drain pipe and shunt pipe.

E.Accessories List

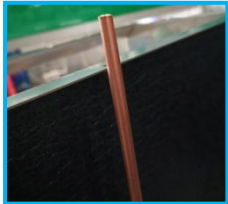
No.	Name	Number	Picture
1	Compressor	2210A01	
2	Evaporator assembly	2210A02	
3	Condenser assembly	2210A03	
4	Hot gas valve	2210A04	

V、Maintenance

5	High pressure switch	2210A05	
6	Controller board	2210A06	
7	Controller display panel	2210A07	
8	Electronic float	2210A08	
9	Fan Blade	2210A09	
10	Fan Motor	2210A10	
11	Shunt	2210A11	
12	Diverter Pipe	2210A12	

V、Maintenance

13	Diverter Pipe Support	2210A13	
14	Pipe For Water Up	2210A14	
15	Water Baffle	2210A15	
16	Water Pump	2210A16	
17	Drain valve	2210A17	
18	Water Inlet Valve	2210A18	
19	Drain Valve Connector	2210A19	

V、Maintenance

20	Expansion Valve	2210A20	
21	Filter Drier	2210A21	
22	Solenoid Valve	2210A22	
23	Condenser Temperature Probe	2210A23	
24	Ice Full Switch	2210A24	
25	Top Cover Plate	2210A25	
26	Back Plate	2210A26	
27	Side Panel(L)	2210A27	

V、Maintenance

28	Side Panel(R)	2210A28	
29	Dust Screen	2210A29	
30	Host Door Panel	2210A30	
31	Ice Bucket Door Panel	2210A31	
32	Water Inlet Pipe	2210A32	
33	Drain Pipe	2210A33	
34	Filter	2210A34	
35	Ice Scoop	2210A35	

F.Before Calling For Service

Check List

When problem occurs in your ice machine ,examination should be conducted first according to the table below before asking for services at the customer's site. Regular adjustment and maintenance procedures are not within the warranty scope.

Fault	Possible cause	Troubleshooting
The ice machine not work	The ice machine not connected to the power supply	Replace the fuse ,reset the over-current protector ,and turn on the power supply
	The ice machine switch is off	Turn the power switch "ON"
	The ice colliding strip is open(downward)	The ice colliding strip must be vertical, swing free.
The ice machine stops . switch "OFF" the machine and turn "ON" again, machine is able to re-start.	The safety limit protection makes the ice machine stop	See next page "Description of safety limit protection"
The ice block is unable to drop from the ice tray and ice collection is slow	Dirty ice machine	Conduct cleaning and disinfection for the ice machine
	Non-horizontal ice machine	Level the ice machine
	The ambient temperature of the ice machine is too low (air cooling type)	The ambient temperature mustn't be lower than 1.7℃
The ice machine fails to collect ice	The 6-minute ice making lock hasn't been completed	Wait for the 6-minute ice making lock to finish
	Dirty ice thickness sensor	Conduct cleaning and disinfection for the ice machine .
	The electric wire of the ice thickness sensor isn't connected	Connect the wire
	The ice thickness sensor isn't properly adjusted	Adjust the ice thickness sensor.
	Unsmooth ice pieces(the ice layer on top of the evaporator is too thin)	See next page"concave or incomplete ice block"
Poor ice block quality (not solid or not clean)	Poor in-take water quality	Ask qualified service company fro water quality test and install proper water filter as recommended
	Poor filtration	Replace the filter
	Dirty ice machine	Conduct cleaning and disinfection for the ice machine
	Abnormal operation of water de- mineralize(if in use)	Repair the water de-mineralize

V、Maintenance

Fault	Possible cause	Troubleshooting
Concave or incomplete ice block or incomplete ice layer on the evaporator	The ice thickness sensor isn't well Adjusted	Adjust the ice thickness sensor
	The water level in the sink is too high or too low	Check the water level.
	Dirty ball float valve filtration	Disassemble the ball float valve and clean the filtration screen
	Poor water filtration	Replace filter
	Hot water enters the ice machine	Connect the water inlet of the ice machine to a cold water source .
	The ball float valve refuses to work.	Disassemble the ball float valve and clean it
	The pressure of the in-take water doesn't comply with the requirement.	The water pressure should be 139.7-551.5Kpa
	The ice machine is not level	Level the ice machine
Small ice output	Dirty ball float valve filtration screen	Disassemble the ball float valve and clean the filtration screen
	The water inlet is closed	Open the water supply valve
	Dirty condenser	Clean the condenser.
	The ball float valve keeps open or leaking	Disassemble the ball float valve and clean it
	The ambient temperature is too high (air cooling type)	The ambient temperature mustn't be higher than 42℃
	Too small space around the ice machine	Proper space should be provided for the ice machine.
	Various matters are placed around the ice machine and the condensation air,circulation is affected	Remove the matters and keep the air well ventilated.

Function of safety omit protection

Besides standard safety control, such as high voltage cut off, the ice machine features built-in limit protection, which is able to protect the major components of the ice machine from being damaged. Before service request at the customer's site, please re*start the ice machine in the following sequence:

1. Push the power supply switch of the ice machine to "OFF" and then back to "ON"
 - A: If the safety limit device makes the ice machine stop, it will re-start after a while. Proceed to step 2.
 - B: If the ice machine is unable to re-start automatically, handle the problem according to the relevant content of "The ice machine refused to work" in the fault table above.

2. Make the ice machine operate to see whether the situation will reoccur.
 - A: If the ice machine stops again, ask the professional maintenance personnel to service on site.
 - B: If the ice machine continues to run, it means the machine is in good condition and can keep running.

Safety limit

Besides standard safety protection, two safety limit protection devices are built in the control panel to protect the major components of the ice machine from being damaged.

Safety limits#1: When the ice making time reaches 60 minutes, the control panel will automatically switches to ice collecting process. If each of two consecutive ice making processes reaches 60 minutes, the ice machine will stop.

Safety limits#2: When the ice collection time reaches 4.5minutes, the control panel will be forced to switch to ice making process. If each of three consecutive ice collecting processes reaches 4.5 minutes, the ice machine will stop.

Identify causes of safety limit stop

When the machine fails to operate because of safety limit, the pilot light on the control panel will flash continuously.

1. In the case of safety limit #1,green pilot light flashes.
2. In the case of safety limit #2,yellow pilot light flashes.

Safety limit #1

Each of two consecutive ice making processes exceeds 60 minutes.

Possible cause	Examination/correction
Improper installation	Refer to chapter II" Installation Description" of this manual
Water System	<ul style="list-style-type: none"> ●Low water pressure 0.14Mp ●High water pressure 0.55Mp ●Too high water temperature(It must not exceed89.6 ° F) ●Blocked water dividing system ●Dirty or damaged ball float valve ●Water loss from the water diversion system ●Damaged water pump
Electric System	Poor wiring connection Controller out of adjustment Controller faulty
poor condensation	Hot environment Condenser too small Air filter dirty Condenser fins dirty Condenser fan faulty
Refrigeration system	Refrigeration system leaking Hot gas valve faulty system has moisture or TXV faulty or TXV blocked fan circulation controller faulty Capillary blocked Compressor valve leaking internal Discharge pressure too high

Safety limits #2

Each of three consecutive ice collecting processes exceeds 3.5 minutes

Possible Cause	Examination/correction
incorrect installation	Refer to chapter II "Installation" of this manual
Water System installation incorrectly	Dirty water flowing area (evaporation coil) Icing up on the back of the evaporation coil. Low water pressure (it mustn't be lower than 0.14Mpa)Blocked water dividing piping Dirty or damaged ball float valve, water pump faulty
Electric System	Poor wiring connection Controller out of adjustment Controller faulty
Refrigeration system	Refrigeration system leaking Hot gas valve faulty system has moisture or TXV faulty or TXV blocked fan circulation controller faulty Capillary blocked Compressor valve leaking internal Discharge pressure too high

Some external factors are also be the protection shutdown, therefore, it is necessary to check.

information and technical parameters are subject to change without notice.

Contact mail: info@pakroman.com

Contacts: Johnson

Toll Free: 877-834-4218

Working hours: 8:30am-5:30pm (Pacific Time)

Pakroman North America Inc

1226 North King St. #304 Wilmington DE 19801