



**INSTRUCTIONS D'ASSEMBLAGE
ASSEMBLY INSTRUCTIONS**

**TABLE A MANGER -
32"X 48" / TAUPE FONCE**

**DINING TABLE -
32"X 48" / DARK TAUPE**



**POUR DE L'ASSISTANCE OU POUR COMMANDER
DES PIÈCES CONTACTEZ NOTRE DÉPARTEMENT
DE SERVICE À LA CLIENTÈLE.**

**FOR ASSISTANCE OR TO ORDER PARTS
CONTACT OUR CUSTOMER SERVICE DEPARTMENT**

LISTE DES PIÈCES
PARTS LIST

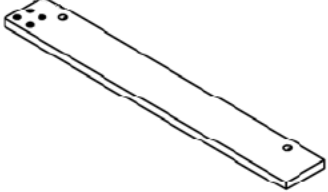
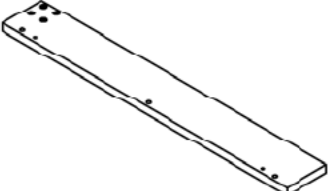
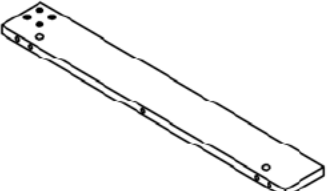
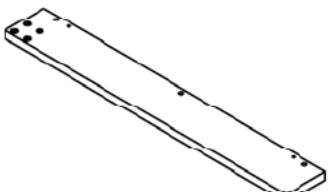
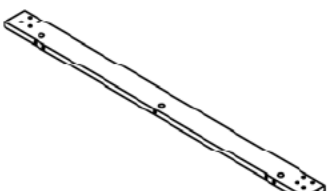
PIÈCE / PART #	IMAGE	DESCRIPTION	QTY / QTÉ
1		LEG PATTE	2
2		LEG PATTE	2
3		LEG PATTE	2
4		LEG PATTE	2
5		CROSSBAR BARRE TRANSVERSALE	2

LISTE DES PIÈCES
PARTS LIST

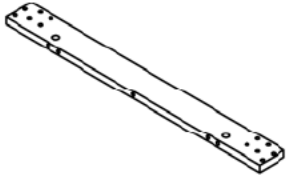
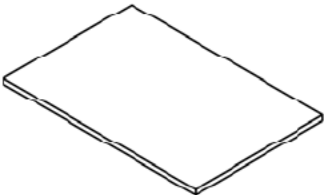
PIÈCE / PART #	IMAGE	DESCRIPTION	QTY / QTÉ
6		CROSSBAR BARRE TRANSVERSALE	2
7		TABLE TOP SURFACE DE TABLE	1

LISTE DES PIÈCES DE MONTAGE
HARDWARE LIST

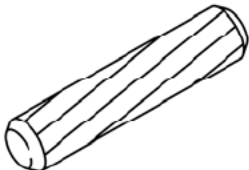
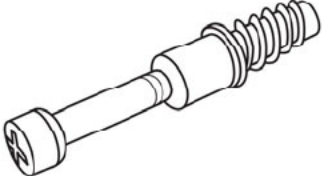
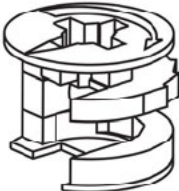
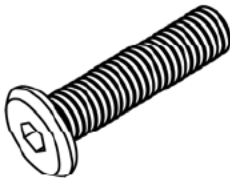
PIÈCE / PART #	IMAGE	DESCRIPTION	QTY / QTÉ
A		GLUE - 40G COLLE - 40G	1
B		WOOD DOWEL - Ø3/8" X 1 1/8" GOUJON DE BOIS - Ø3/8" X 1 1/8"	30
C		CAM LOCK SCREW - 1 3/8" VIS CAM LOCK - 1 3/8"	18
D		CAM LOCK CONNECTOR - Ø5/8" X 1/2" ÉCROU CAM LOCK - Ø5/8" X 1/2"	18
E		ASSEMBLING BOLT - 1 3/8" BOULON D'ASSEMBLAGE - 1 3/8"	32

LISTE DES PIÈCES DE MONTAGE
HARDWARE LIST

PIÈCE / PART #	IMAGE	DESCRIPTION	QTY / QTÉ
F	 A line drawing of a circular floor protector with a pencil-like tip protruding from its center.	FLOOR PROTECTOR - 3/4" PROTECTEUR DE PLANCHER - 3/4"	8
G	 A line drawing of a rectangular sheet of finishing sticker with six circular patterns arranged in two rows of three.	FINISHING STICKER - 3/4" COLLANT DE FINITION - 3/4"	18
H	 A line drawing of a hexagonal key, showing its long handle and the hexagonal end.	HEX KEY CLÉ HEXAGONALE	1

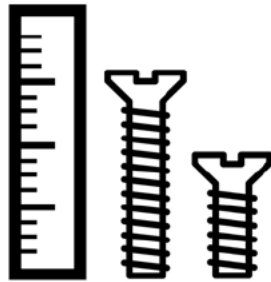

**OUTIL DE VÉRIFICATION DE DIMENSIONS DES PIÈCES
HARDWARE DIMENSIONS VERIFICATION TOOL**

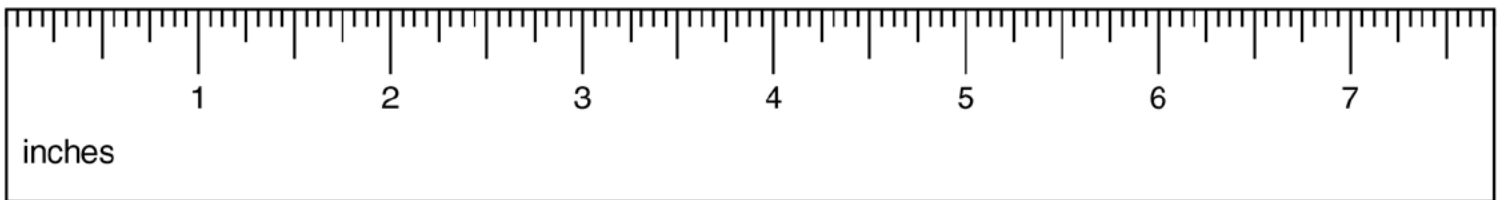

ÉTAPE / STEP 1

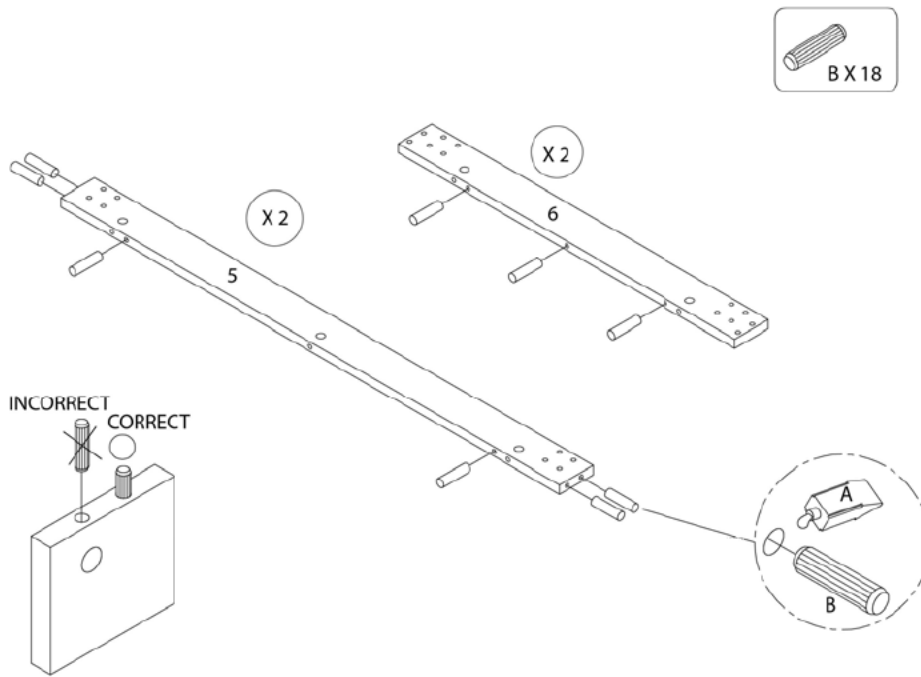

ÉTAPE / STEP 2

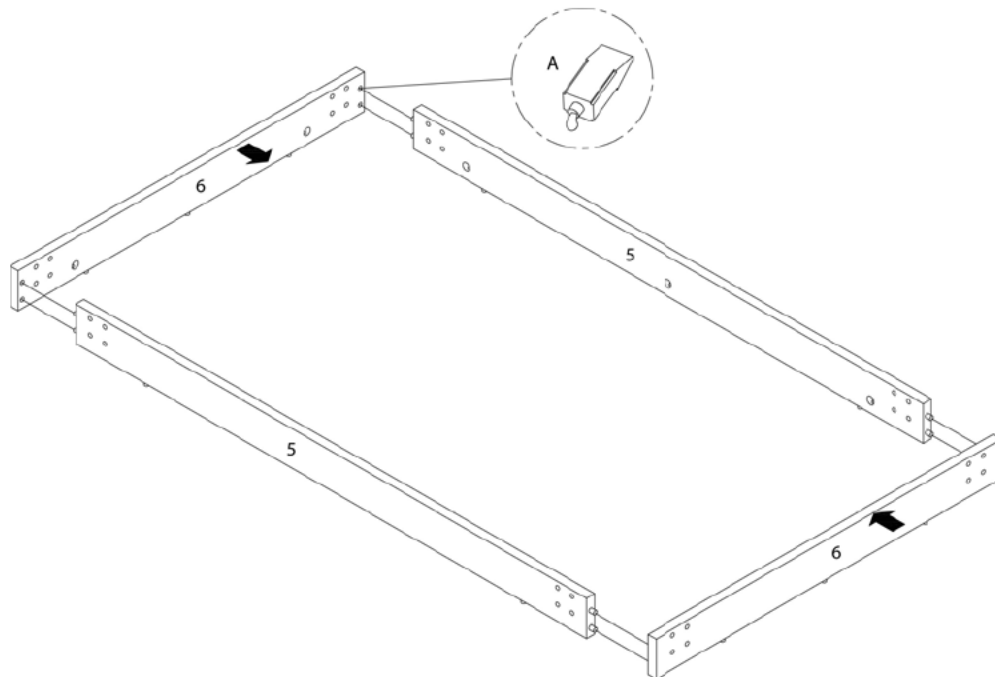

ÉTAPE / STEP 3

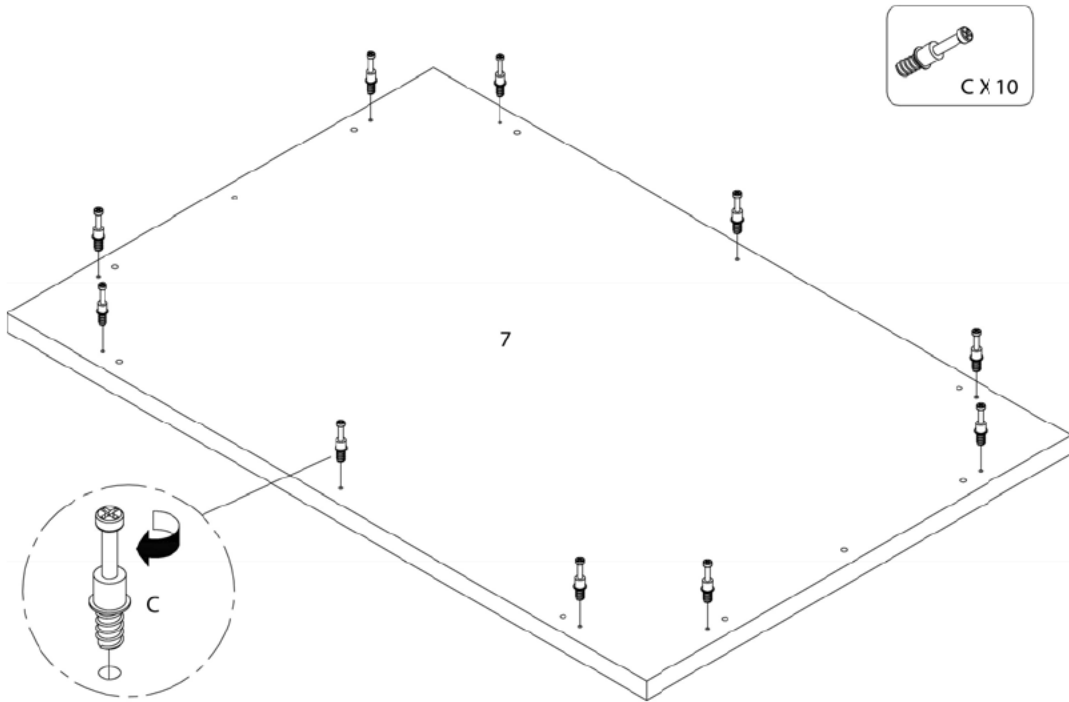

ÉTAPE / STEP 4

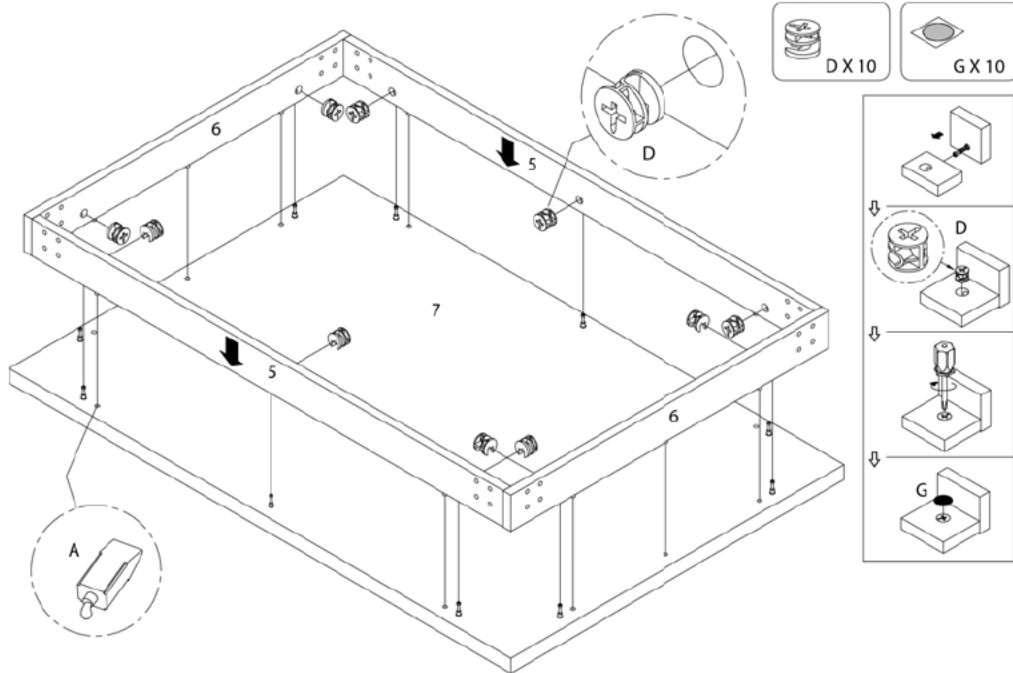

ÉTAPE / STEP 5

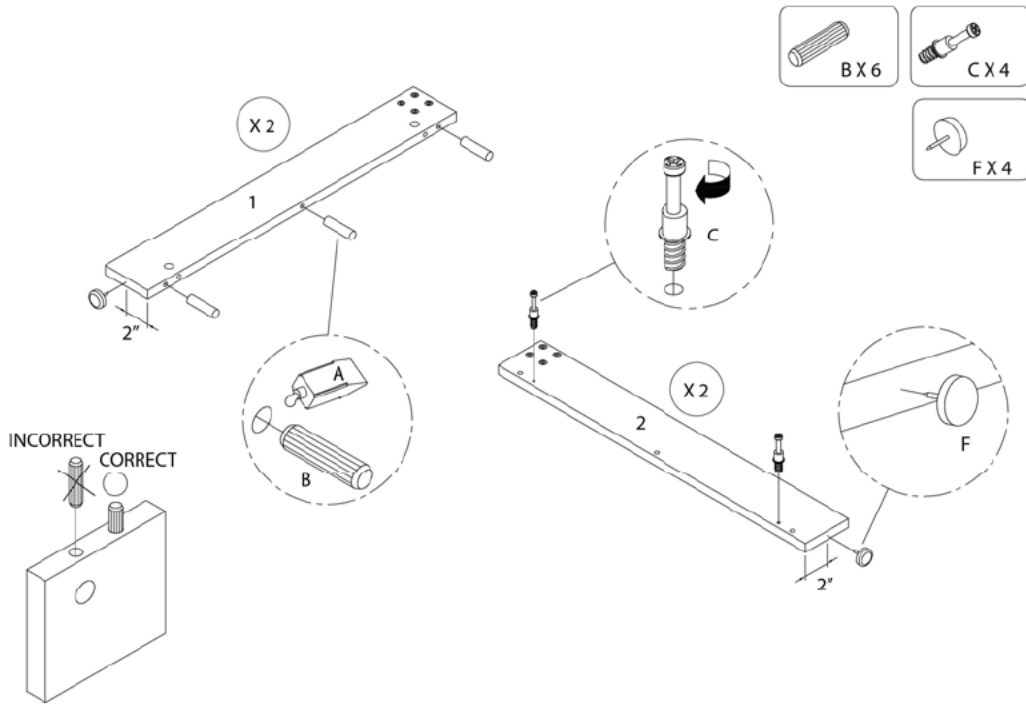

ÉTAPE / STEP 6

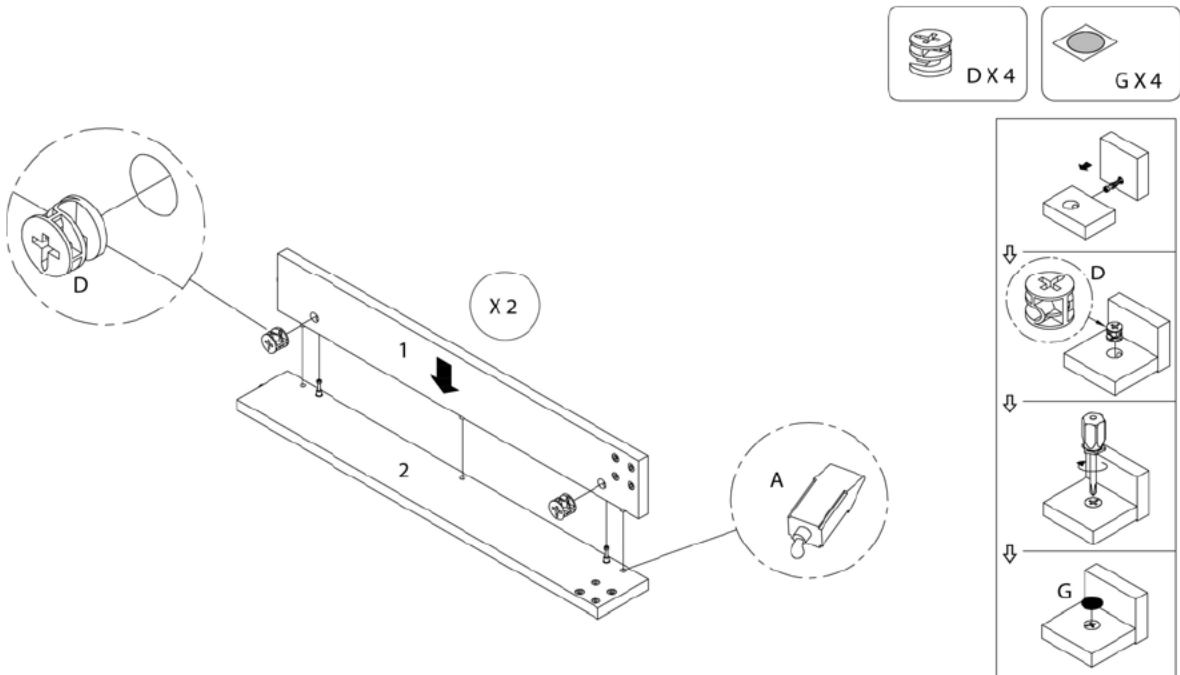

ÉTAPE / STEP 7

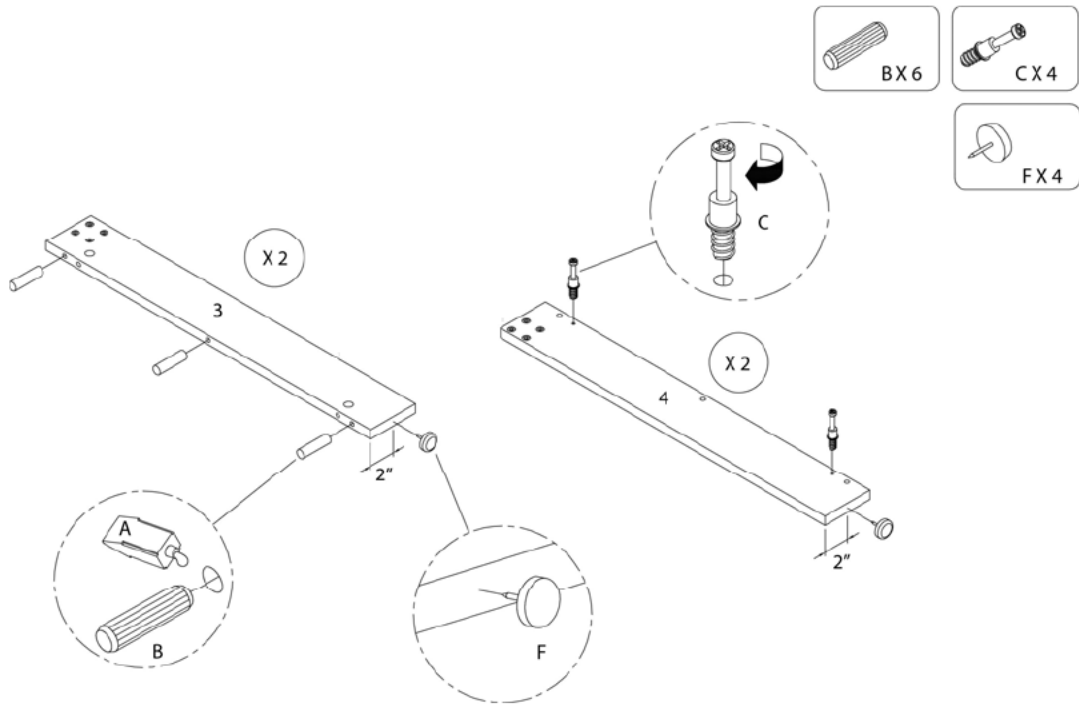

ÉTAPE / STEP 8

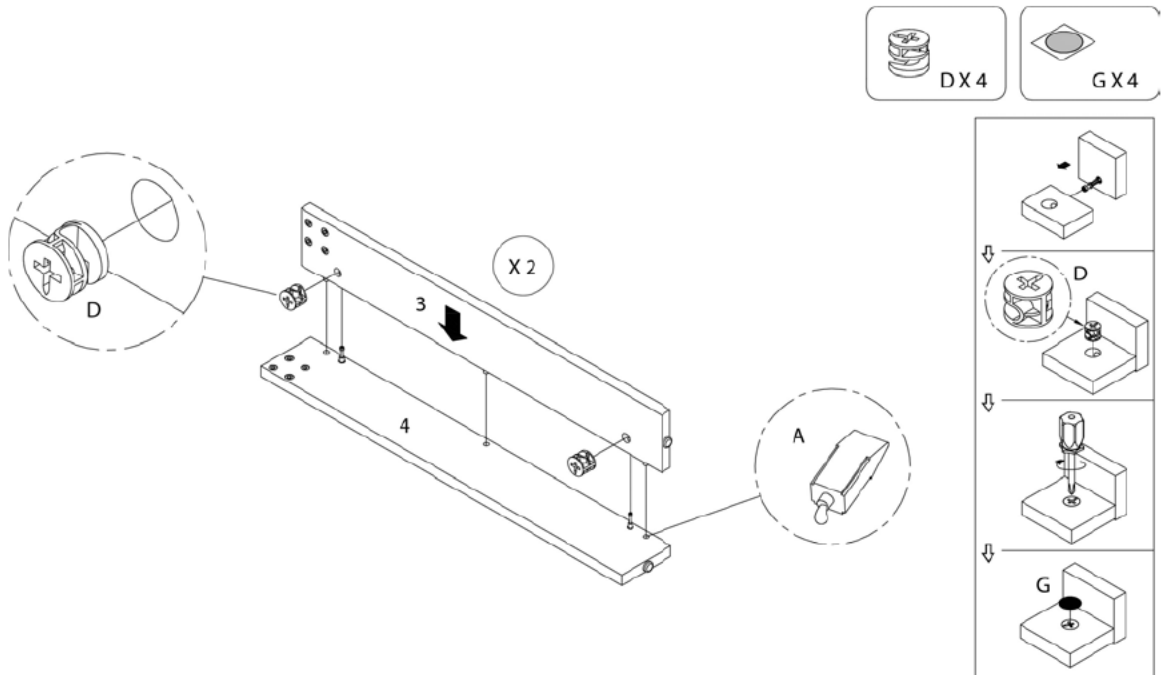

ÉTAPE / STEP 9

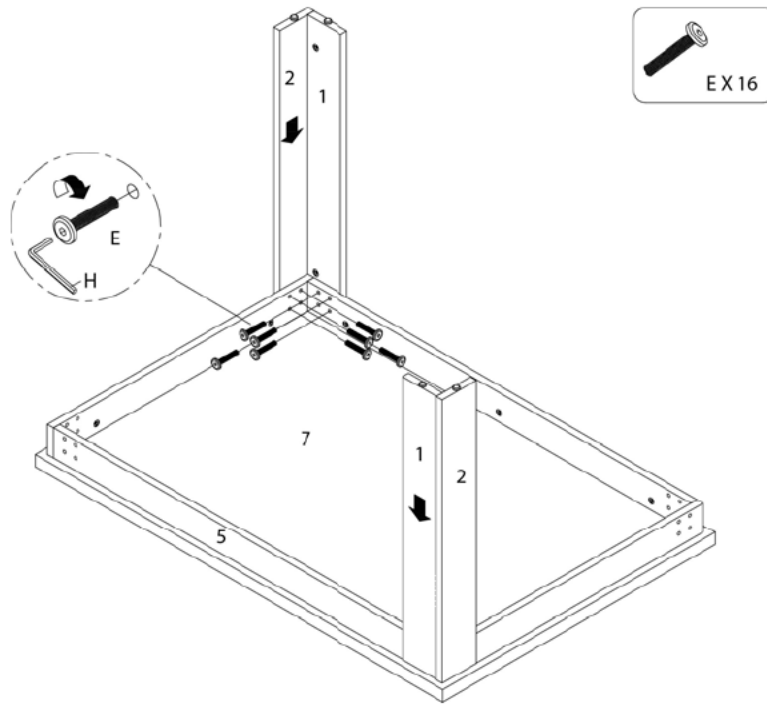

ÉTAPE / STEP 10

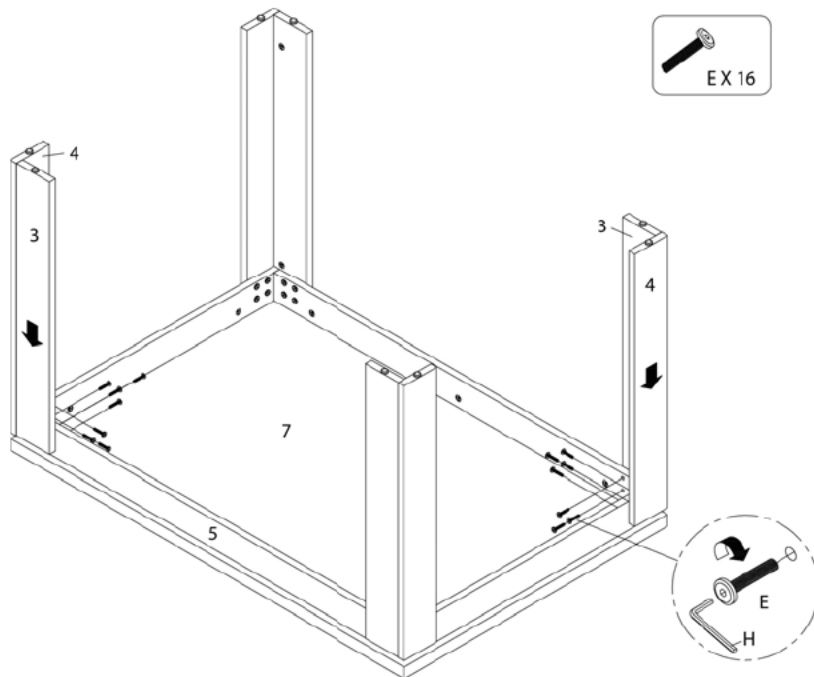

ÉTAPE / STEP 11

