

# **WARNING!!**

## **Furniture Tipping Risk.**

**Serious risk of severe or fatal crush injuries can occur from furniture tipping over if not secured.**

**Children like to climb on furniture and Unsecured furniture can pose a serious danger.**

**Please follow all instructions and install the tip-over restraints provided.**

**In addition to installing the restraints, to help prevent tip-over:**

- 1. Place heaviest items in the lowest drawers,**
- 2. Unless specifically designed to accommodate, do not set TV's or other heavy objects on top of this product,**
- 3. Never allow children to climb or hang on drawers, doors, or shelves,**
- 4. Do not leave drawers open,**
- 5. Never open more than one drawer at a time, and**
- 6. Do not step on the base.**

# Assembly Instructions

CAUTION: You must read these Assembly Instructions before you proceed.

## Care & Maintenance



- Not for commercial use. For residential use only.



- Do not put hot items directly on furniture surface.



- Do not clean furniture with harsh cleansers or polish.



- To obtain the longest lifespan of your outdoor products, minimizing exposure to direct sunlight is recommended.



- Children should not climb or jump on the furniture.



- Do not write on furniture without a padded barrier to protect the surface.



- To obtain the longest lifespan of your outdoor products, avoid extended and lengthy exposure to rain, snow, and direct sunshine. Whenever possible cover the product and /or place under patio or awnings.



- Stains may be removed with mild soap solution and damp cloth.



- Dust and pick-up spills using a clean, non-colored, lint-free cloth.

Please look in carton for hardware packs and legs.

Sets often ship in multiple boxes and may arrive a day or two apart

# Assembly Instructions

CAUTION: You must read these Assembly Instructions before you proceed.





Please look into the Hardware Bag for all hardware.

## **OUTDOOR ACACIA WOOD BAR CART**



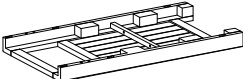
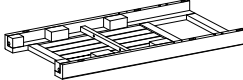
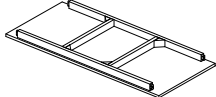
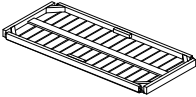
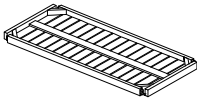
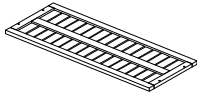
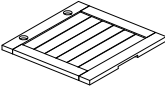
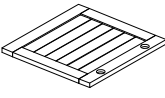



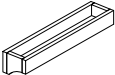



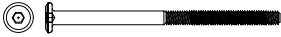

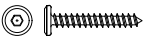
CAUTION: This Outdoor Acacia Wood Bar Cart is NOT a TOY.  
Keep your child / children at bay during the assembly process.  
Whenever lifting or moving the Bar Cart and to prevent damage to the Bar Cart, two adult partners may be needed to execute these actions.

**Parts List :**

| Label | Picture   | Description     | QTY |
|-------|---|-----------------|-----|
| A     |    | Side Left       | 1   |
| B     |    | Side Right      | 1   |
| C     |    | Top             | 1   |
| D     |    | Upper shelf     | 1   |
| E     |    | Lower shelf     | 1   |
| F     |    | Middle shelf    | 1   |
| G     |   | Left door       | 2   |
| H     |  | Right door      | 2   |
| I     |  | Back bracket    | 2   |
| J     |  | Front bracket   | 2   |
| K     |  | Push handle bar | 2   |
| L     |  | Storage shelf   | 1   |

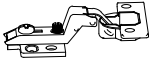
**Hardware :**

| Label | Picture   | Description          | QTY |
|-------|---|----------------------|-----|
| ①     |  | Bolt<br>(M6x100 mm)  | 13  |
| ②     |  | Bolt<br>(M6x70 mm)   | 13  |
| ③     |  | Screws<br>(M6x35 mm) | 10  |

|   |   |                           |    |
|---|---|---------------------------|----|
| ④ |  | Barrel Nuts<br>(M6x15 mm) | 13 |
| ⑤ |  | Magnetic latch            | 4  |
| ⑥ |  | Screws<br>(M3.5x15 mm)    | 9  |
| ⑦ |  | Hinge                     | 8  |
| ⑧ |  | Screws<br>(M4x15 mm)      | 49 |
| ⑨ |  | Wheel                     | 4  |
| ⑩ |  | Allen Wrench(M4)          | 2  |

### Assembly Preparation :

Before Beginning Assembly:

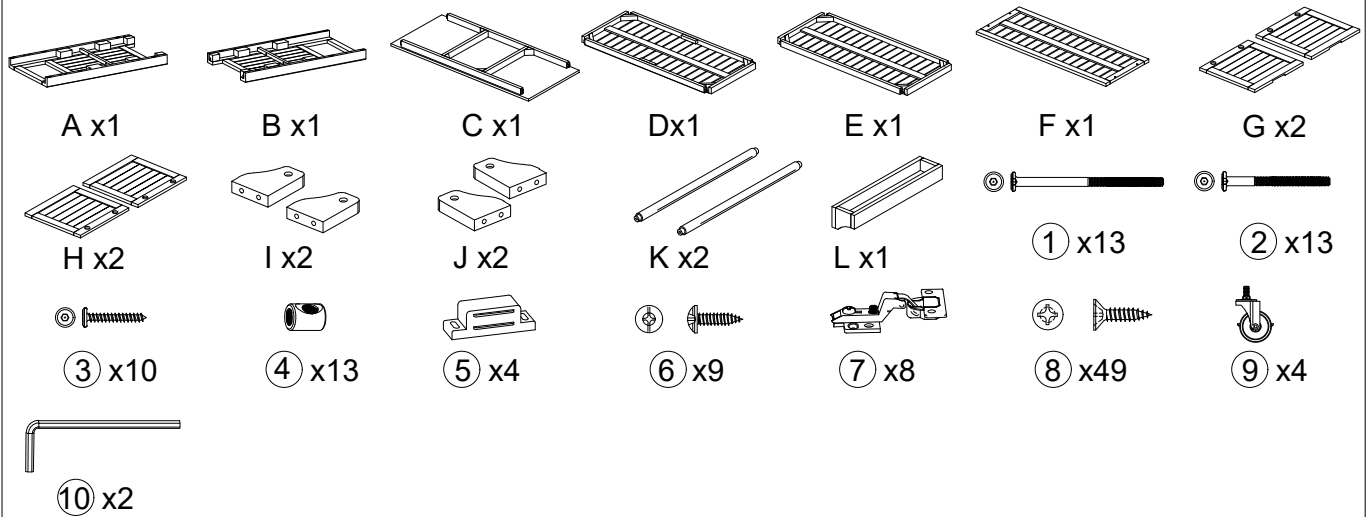

- Read instructions, cover to cover.



- Have 2 adults on hand for assembly.



- Do not assemble on flooring or carpet



- Assemble on a clean non-marring surface (packing foam)



- Save all packaging until finished.

## Assembly Steps:

### Overview

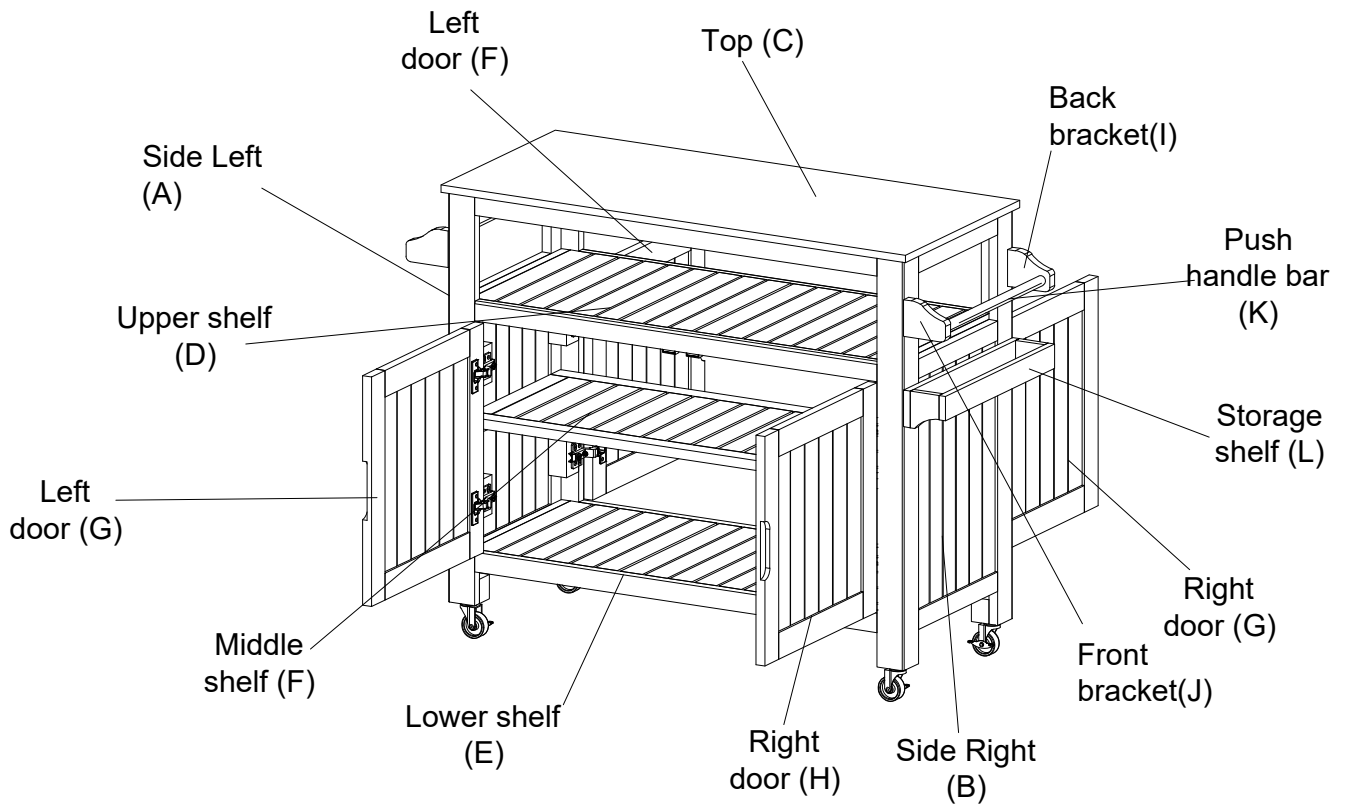

This bar cart has multiple parts and may require up to some 1 hours to assemble. To give you an overview of the bar cart parts, the above picture is to help you put the various parts into perspective. Please read through the instructions below to familiarise yourself with the parts and steps before assembly.

### Step 1

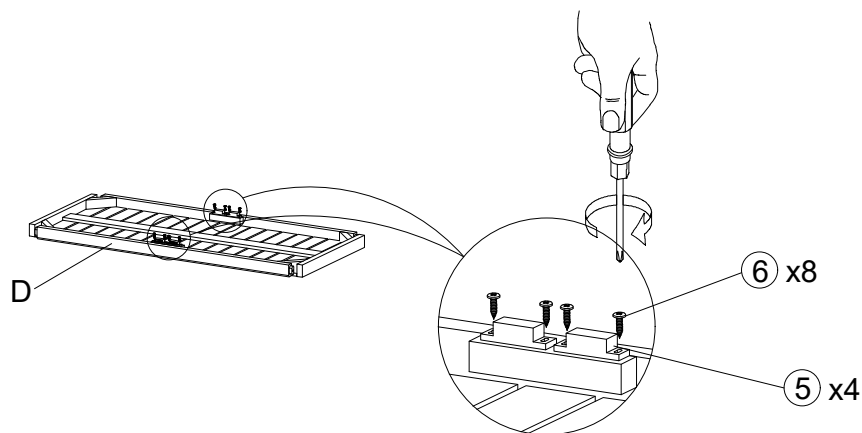

1/ Attach the 4 magnetic latches (5) to the Upper Shelf (C) using 8 screws (M3.5 × 15 mm). Tighten them with a screwdriver.

## Step 2

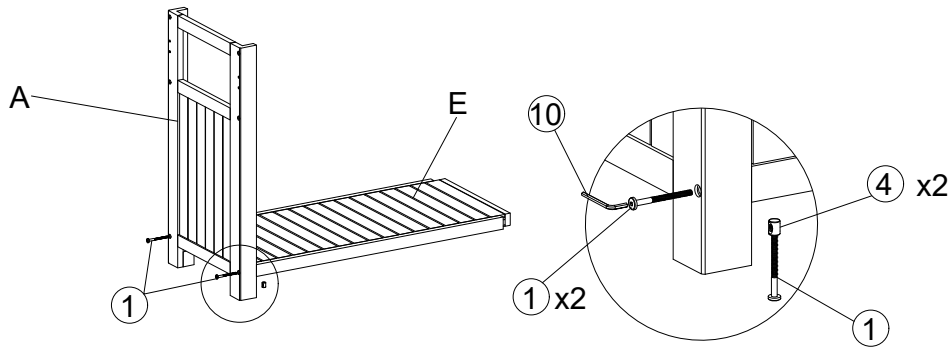

2/ Attach the Side Leg (A) to the Lower Shelf (D) using 2 bolts (M6 × 100 mm) and 2 barrel nuts (M6 × 15 mm). Tighten with the Allen Wrench (M4).

DO NOT fully tighten the Bolts at this time.

## Step 3

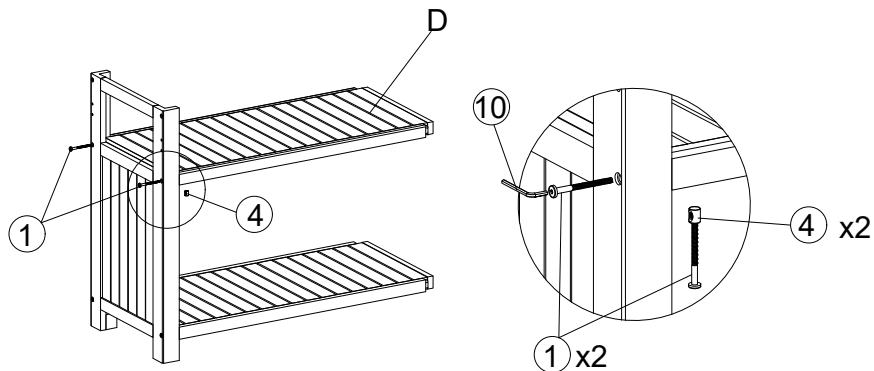

3/ Attach it to the Upper Shelf (C) using 2 bolts (M6 × 100 mm) and 2 barrel nuts (M6 × 15 mm). Tighten with the Allen Wrench (M4).

DO NOT fully tighten the Bolts at this time.

## Step 4

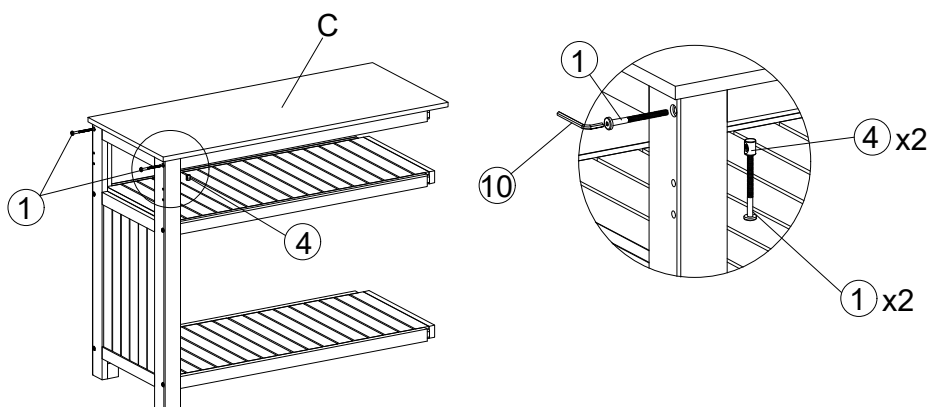

4/ Attach it to the Top (B) using 2 bolts (M6 × 100 mm) and 2 barrel nuts (M6 × 15 mm). Tighten with the Allen Wrench (M4).

DO NOT fully tighten the Bolts at this time.

### Step 5

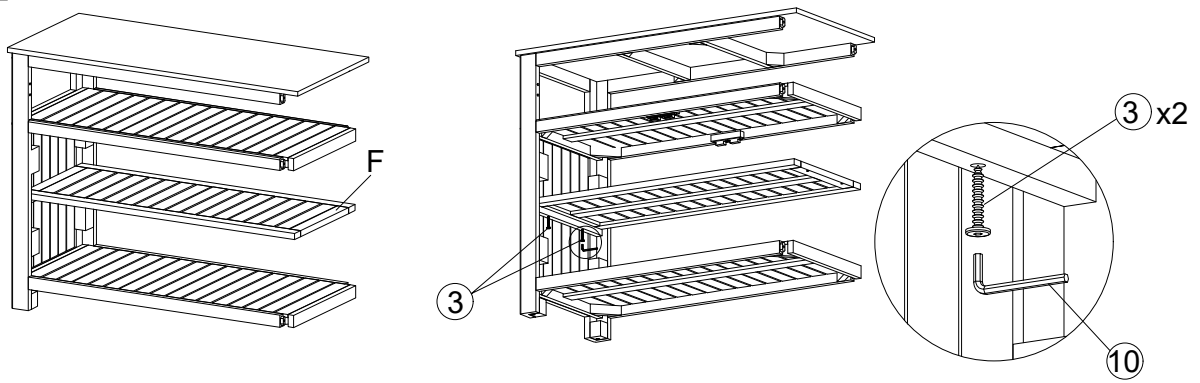

5/ Attach it to the Middle Shelf (E) using 2 screws (M6 × 35 mm). Tighten with the Allen Wrench (M4).  
DO NOT fully tighten the Bolts at this time.

### Step 6

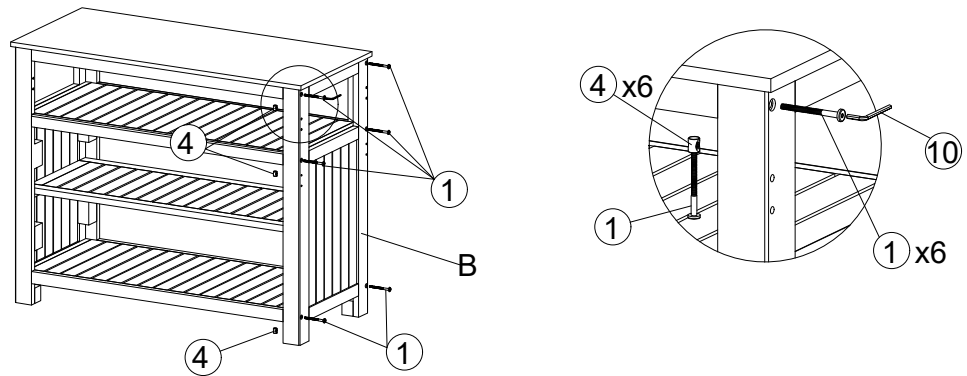

6/ Attach the remaining Side Leg(A) using 6 bolts (M6 × 100 mm) and 6 barrel nuts (M6 × 15 mm). Tighten with the Allen Wrench (M4).  
DO NOT fully tighten the Bolts at this time.

### Step 7

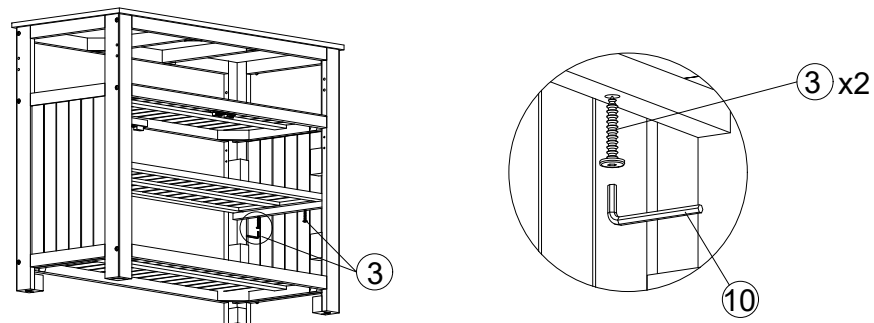

7/ Tighten the 2 screws (M6 × 35mm) with the Allen Wrench (M4).  
DO NOT fully tighten the Vis at this time.

## Step 8

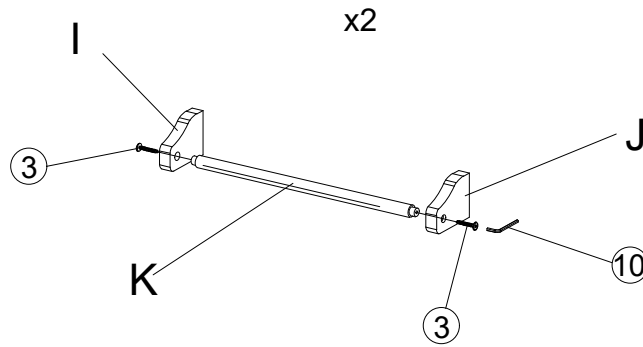

8/ Attach the Back bracket(H) to the Font bracket(I) and the Push Handle Bar(J) using 2 screws (M6 × 35 mm). Tighten with the Allen Wrench (M4).  
DO NOT fully tighten the Bolts at this time.

## Step 9

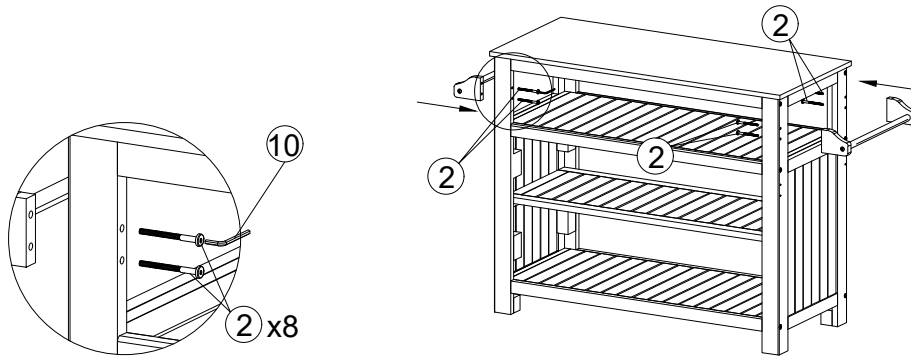

9/ Attach it to the cabinet body using 8 bolts (M6 × 70 mm). Tighten with the Allen Wrench (M4).  
DO NOT fully tighten the Bolts at this time.

## Step 10

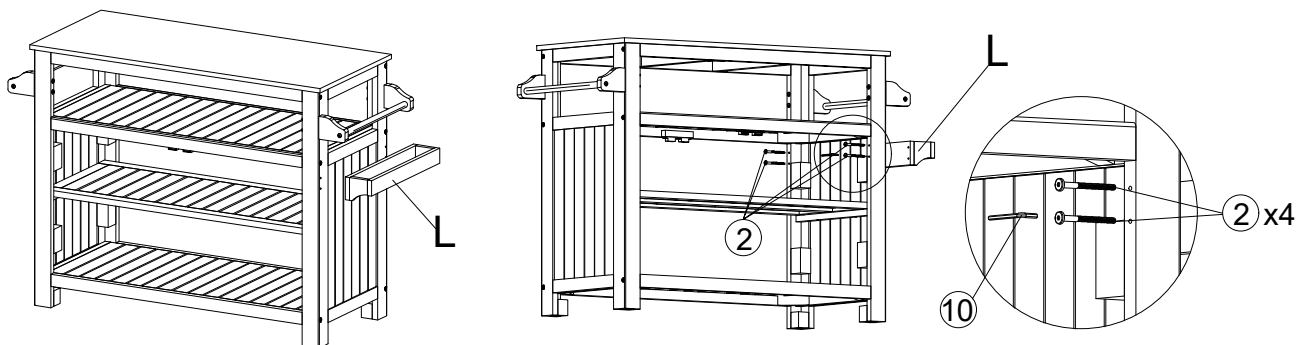

10/ Attach the Storage Shelf (K) using 4 bolts (M6 × 70 mm). Tighten with the Allen Wrench (M4).  
Fully tighten the Bolts/Vis at this time.

### Step 11

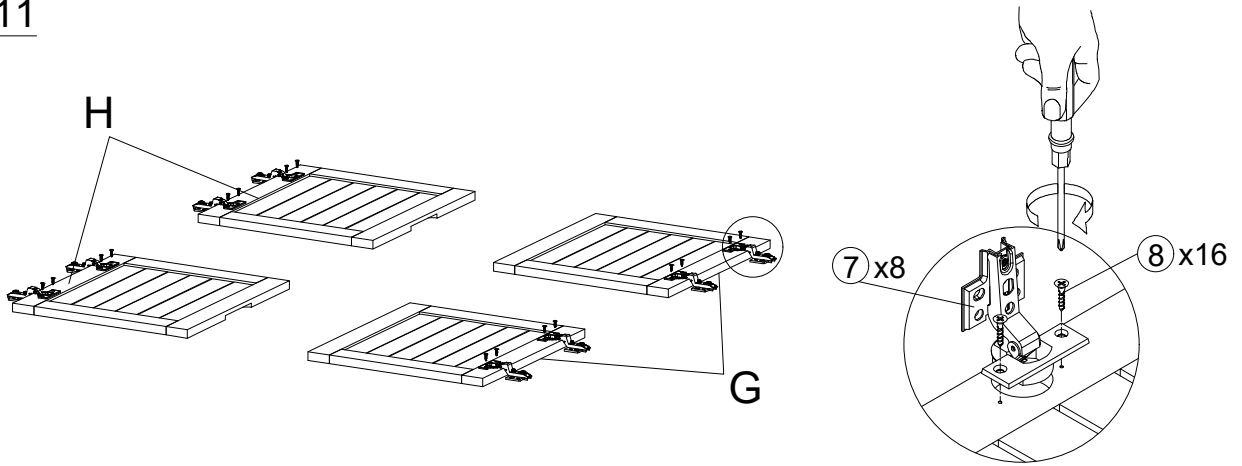

11/ Attach 8 hinges to the 2 Left Doors (G) and 2 Right Doors (H) using 16 screws (M4×15mm).

### Step 12

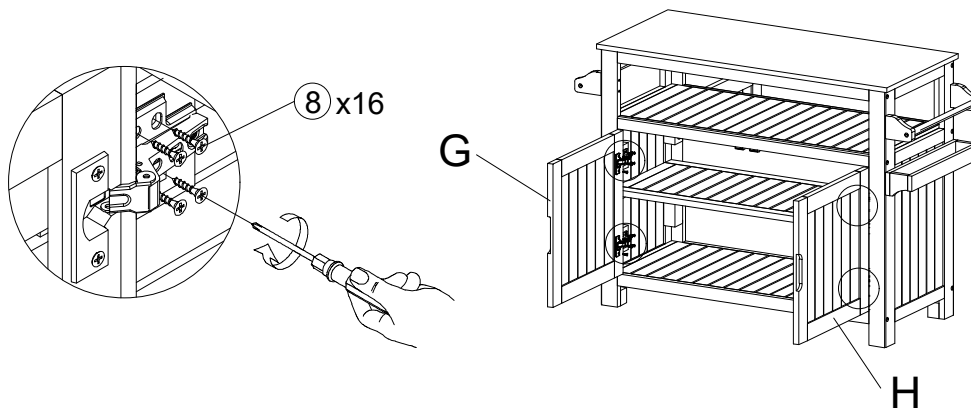

12/ Attach the 1 Right Door(H) and 1 Left Door(G) to the front cabinet body using 16 screws (M4 × 15 mm). Tighten clockwise with a screwdriver.

### Step 13

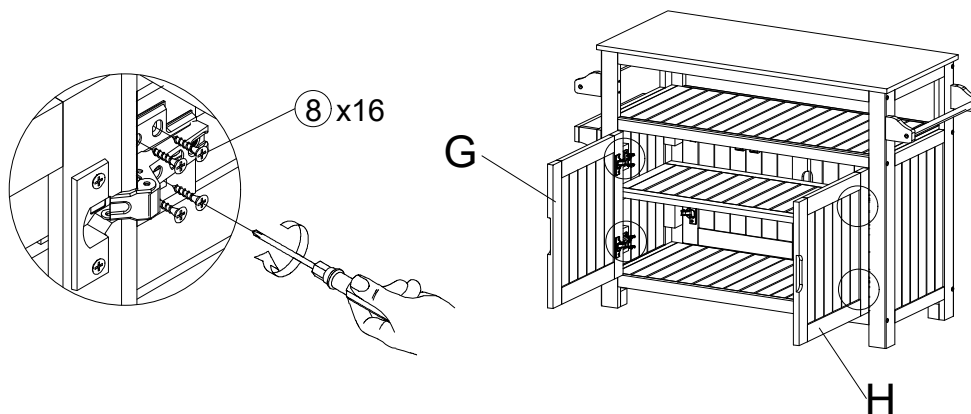

13/ Attach the 1 Left Door(G) and 1 Right Door(H) to the back cabinet body using 16 screws (M4 × 15 mm). Tighten clockwise with a screwdriver.

## Step 14

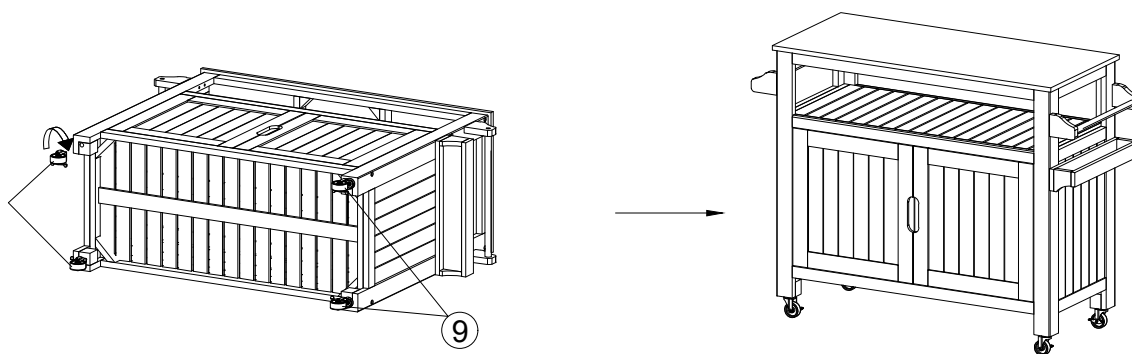

14/Lay the cabinet on its side and install the four wheels(9) onto its four legs, tightening them clockwise. Then, stand the cabinet upright as shown in the picture

## Adjusting door hinges and wheels

**1.Back and Forth Adjustment:** To move the cabinet door closer to or farther from the cabinet frame

**2.Left and Right Adjustment:** To shift the cabinet door sideways for alignment.

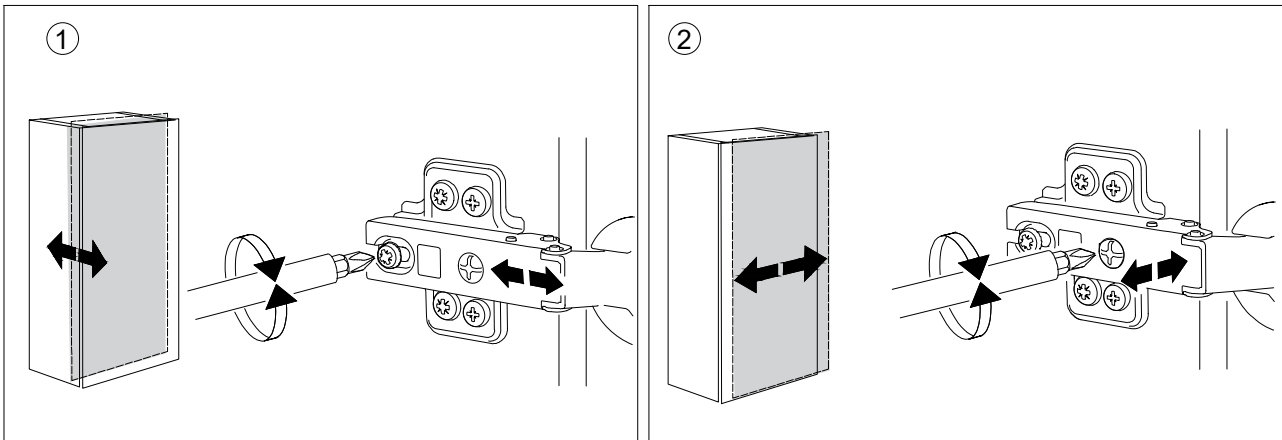

### TIPS FOR ADJUSTMENT:

These “adjustments” are not preset and will need to be checked to meet the desired look

- We recommend the use of a #2 Phillips Screwdriver.
- Adjust in small steps and check your progress frequently.
- Use a measuring tape to ensure the gaps between the top and bottom of the door are even.
- Avoid forcing the door closed if it does not align properly, as this may damage the door
- If the alignment is still off, make further adjustments as needed.

By following these steps, you can achieve a balanced door alignment.

If you need further adjustments, repeat the process in small increments.

### Important notes

While adjusting the hinges, firmly hold the door in place to prevent it from falling and getting damaged.

Repeatedly tightening and loosening the hinge screws can cause the screw holes to widen. To avoid this, minimize adjustments and avoid overtightening.

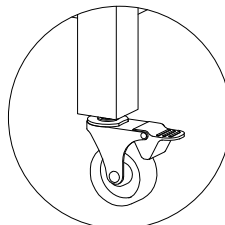

**ON**

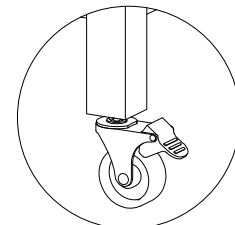

**OFF**

**To lock the wheel:**

- Press the brake lever down until it engages. When the brake is activated, the wheel is locked

**To unlock the wheel:**

- Pull the brake lever up to release it. Once the brake is disengaged, the wheel can rotate and move freely.

## Questions & Answers about Proposition 65

- What is Proposition 65?

Proposition 65 requires businesses to provide warnings to Californians about significant exposures to chemicals that cause cancer, birth defects or other reproductive harm. These chemicals can be in the products that Californians purchase, in their homes or workplaces, or that are released into the environment. By requiring that this information be provided, Proposition 65 enables Californians to make informed decisions about their exposures to these chemicals.

Proposition 65 also prohibits California businesses from knowingly discharging significant amounts of listed chemicals into sources of drinking water.

Proposition 65 requires California to publish a list of chemicals known to cause cancer, birth defects or other reproductive harm. This list, which must be updated at least once a year, has grown to include approximately 900 chemicals since it was first published in 1987.

- What types of chemicals are on the Proposition 65 list?

The list contains a wide range of naturally occurring and synthetic chemicals that include additives or ingredients in pesticides, common household products, food, drugs, dyes, or solvents. Listed chemicals may also be used in manufacturing and construction, or they may be byproducts of chemical processes, such as motor vehicle exhaust.

- What does a warning mean?

If a warning is placed on a product label or posted or distributed at a workplace, a business, or in rental housing, the business issuing the warning is aware or believes that it is exposing individuals to one or more listed chemicals.

By law, a warning must be given for listed chemicals unless the exposure is low enough to pose no significant risk of cancer or is significantly below levels observed to cause birth defects or other reproductive harm.

- Where can I get more information on Proposition 65?

If you have specific questions on the administration or implementation of Proposition 65, you can contact OEHHA's Proposition 65 program at [P65.Questions@oehha.ca.gov](mailto:P65.Questions@oehha.ca.gov), or by phone at (916) 445-6900.