

ASSEMBLY INSTRUCTION

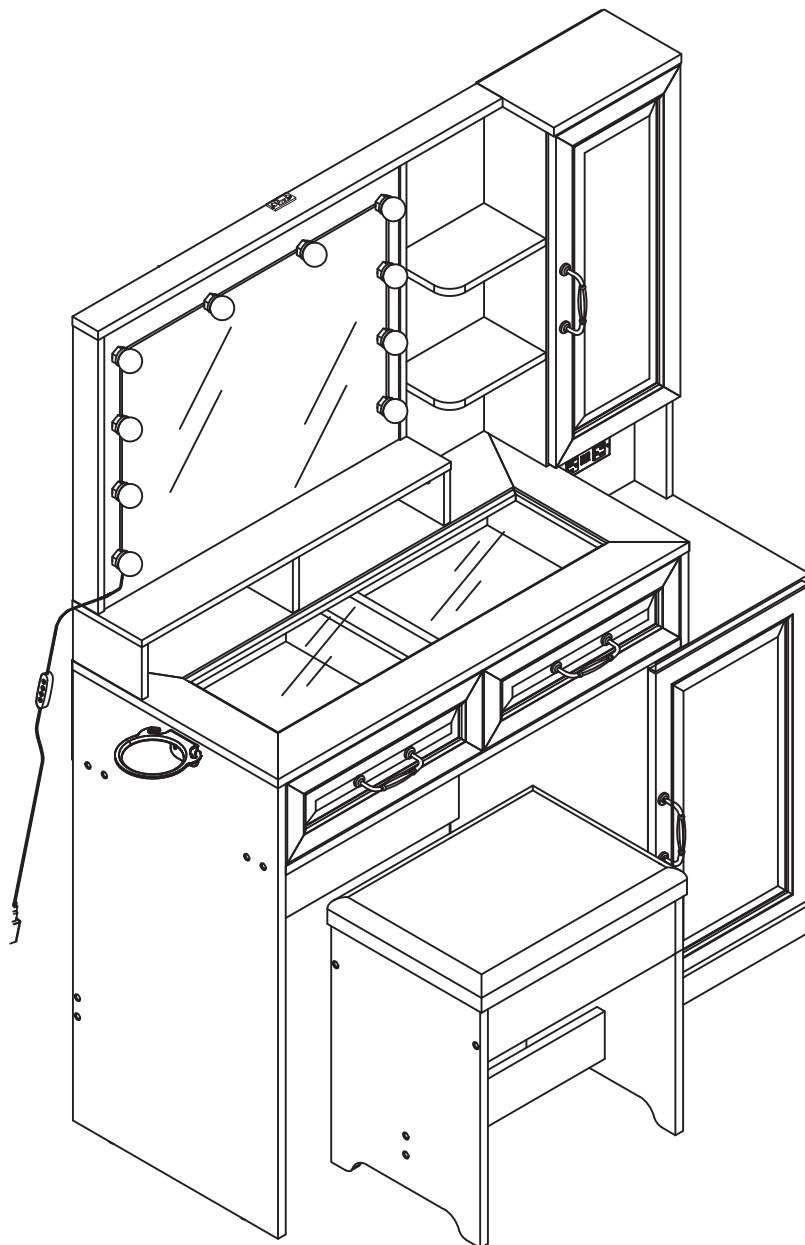

Before You Start

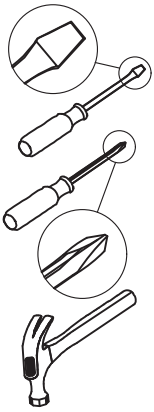

- ✓ Read through each step carefully and follow the proper order
- ✓ Separate and count all your parts and hardware
- ✓ Give yourself enough room for the assembly process
- ✓ Have the following tools: Flat Head Screwdriver, #2 Phillips Head Screwdriver and Hammer
- ✓ Caution: If using a power drill or power screwdriver for screwing, please pay attention to slow down and stop when screw is tight. Failure to do so may result in stripping the screw. (Assembly speed can be increased by using electric screwdriver)

Helpful Hints

PEOPLE NEEDED FOR ASSEMBLY:1-2

- Open your item in the area you plan to keep it to avoid excessive heavy lifting.
- Identify, sort and count the parts before attempting assembly.
- Compression dowels are lightly tapped in with a hammer.
- Slides are labeled with an R (right) and L (left) for proper placement.
- Make sure to always face the point on the top of the Cam Lock towards the outer edge.
- If there is a back panel in the package, please install it to make sure your unit is complete and sturdy.
- Please fix all the screws provided for the back panel which can enhance product stability. If it is difficult to fix it when tightening, it can be fixed with the help of a hammer and then tightened.
- Do NOT use harsh chemicals or abrasive cleaners on this item.
- Never push, pull, or drag your furniture.

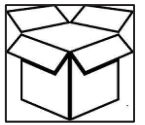

Board Identification

Not actual size

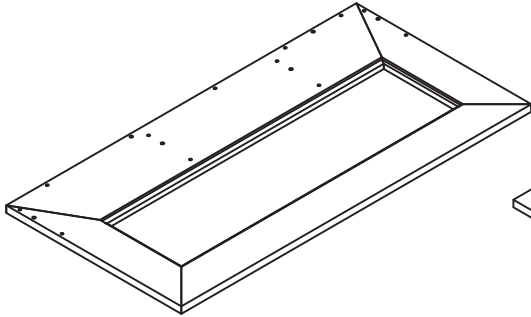

Ⓐ

TOP
Qty:1

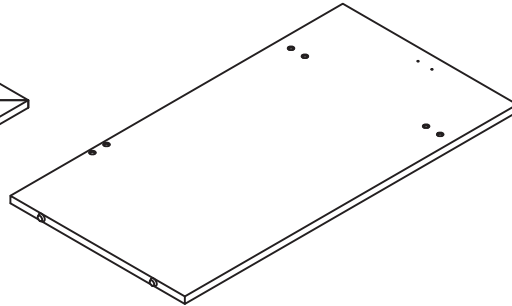

Ⓑ

LEFT SIDE PANEL
Qty:1

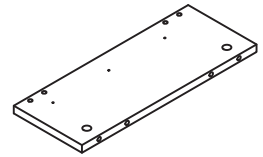

Ⓒ

RIGHT SIDE PANEL
Qty:1

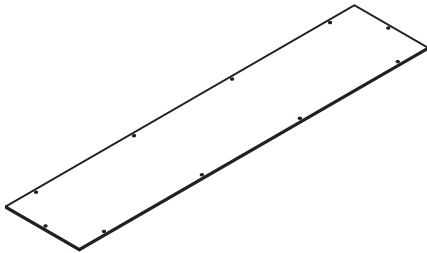

Ⓓ

DESK BACK PANEL
Qty:1

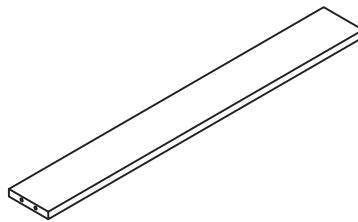

Ⓔ

LOWER BACK SLAT
Qty:1

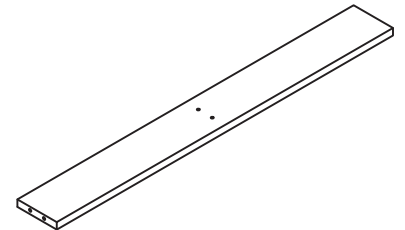

Ⓕ

FRONT SLAT
Qty:1

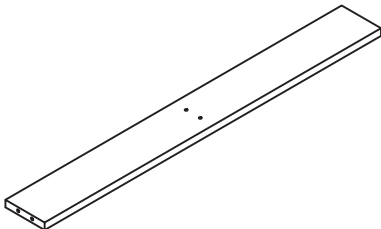

Ⓖ

BACK SLAT
Qty:1

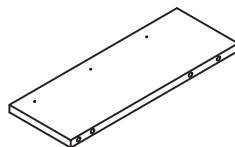

Ⓖ

MIDDLE PANEL
Qty:1

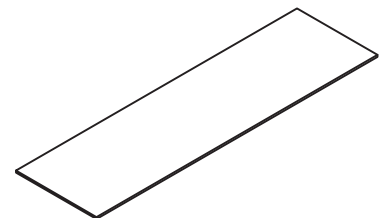

Ⓙ

DESKTOP GLASS
Qty:1

Board Identification

Not actual size

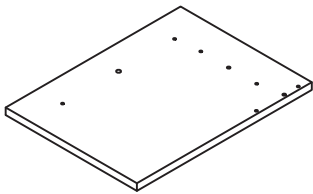

ⓐ

TOP
Qty:1

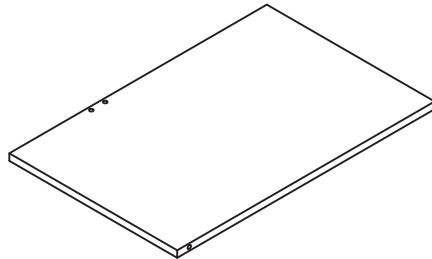

ⓑ

LEFT SIDE PANEL
Qty:1

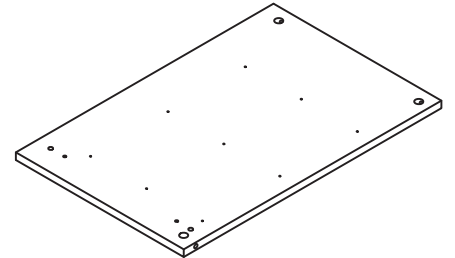

ⓒ

RIGHT SIDE PANEL
Qty:1

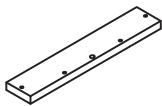

ⓓ

FRONT PANEL
Qty:1

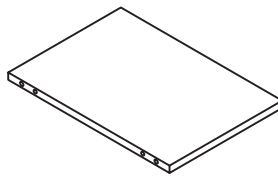

ⓔ

BOTTOM
Qty:1

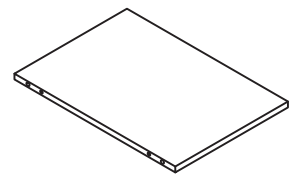

ⓕ

FIXED SHELF
Qty:1

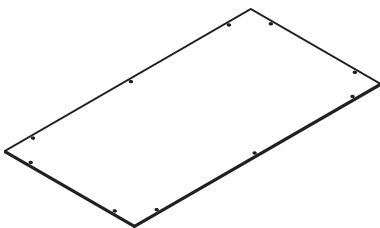

ⓖ

DESK BACK PANEL
Qty:1

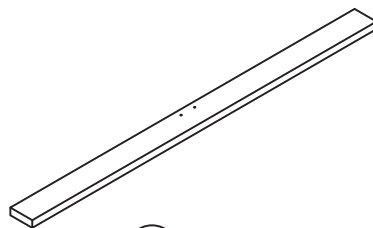

ⓗ

FIXED SHELF
Qty:1

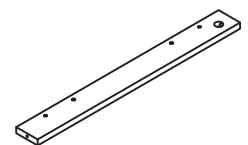

ⓘ

UPPER LEFT SIDE PANEL
Qty:1

Board Identification

Not actual size

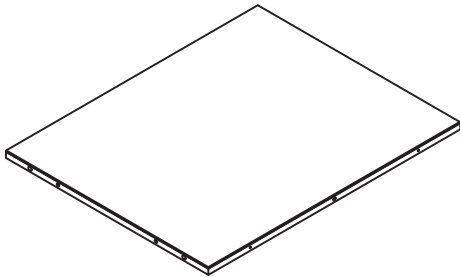

Ⓢ

DRESSING MIRROR
Qty:1

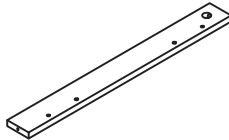

Ⓣ

UPPER LEFT MIDDLE PANEL
Qty:1

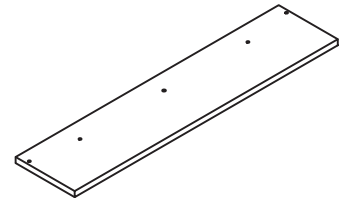

Ⓤ

HUTCH FIXED SHELF
Qty:1



Ⓥ

HUTCH SIDE PANEL
Qty:1



Ⓦ

HUTCH SIDE PANEL
Qty:1

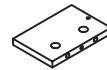

Ⓧ

HUTCH SIDE PANEL
Qty:1

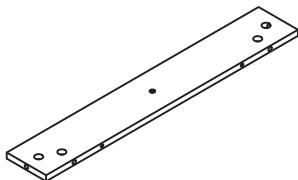

Ⓨ

DESK BACK PANEL
Qty:1

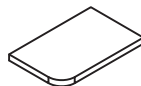

Ⓩ

FIXED SHELF
Qty:2

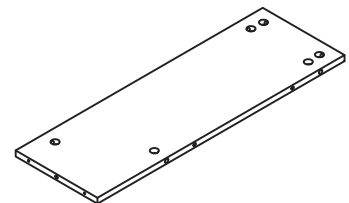

ⒶⒶ

DESK BACK PANEL
Qty:1

Board Identification

Not actual size

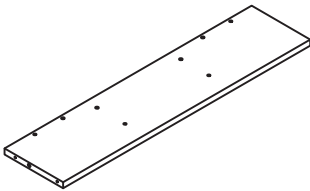

ⓑ

UPPER RIGHT MIDDLE PANEL
Qty:1

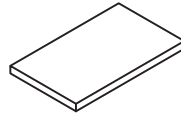

ⓒ

FIXED SHELF
Qty:1

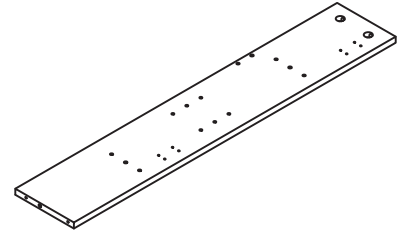

ⓓ

UPPER RIGHT SIDE PANEL
Qty:1

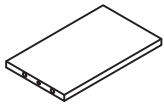

ⓔ

FIXED SHELF
Qty:1

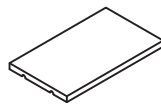

ⓕ

FIXED SHELF
Qty:1

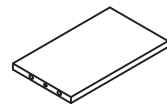

ⓖ

FIXED SHELF
Qty:1

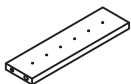

ⓓⓓ

HUTCH FIXED SHELF
Qty:1

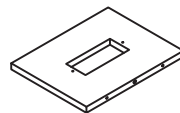

ⓓⓓ

FIXED SHELF
Qty:1

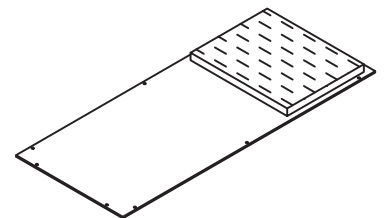

ⓓⓓ

DESK BACK PANEL
Qty:1

Board Identification

Not actual size

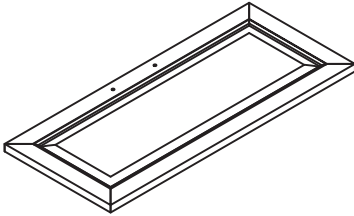

ⓀⓀ

DOOR
Qty:1

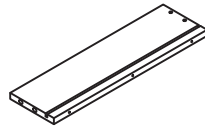

ⓁⓁ

DRAWER LEFT SIDE
Qty:2

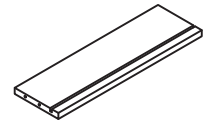

ⓂⓂ

DRAWER BACK PANEL
Qty:2

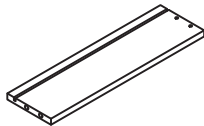

ⓃⓃ

DRAWER RIGHT SIDE
Qty:2

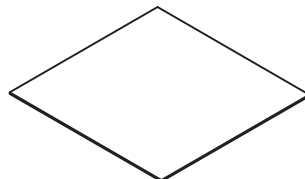

ⓄⓄ

DRAWER BOTTOM
Qty:2

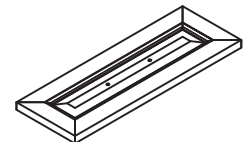

ⓅⓅ

LEFT DRAWER FRONT
Qty:1

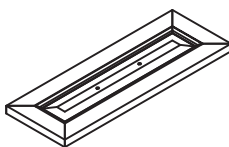

ⓆⓆ

RIGHT DRAWER FRONT
Qty:1

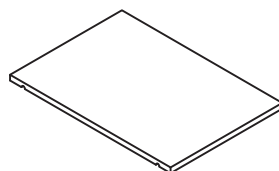

ⓇⓇ

FIXED SHELF
Qty:1

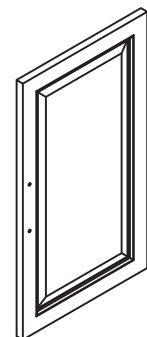

ⓈⓈ

DOOR
Qty:1

Board Identification

Not actual size

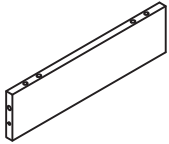

TT

STOOL APRON
Qty:2

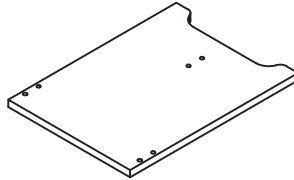

UU

STOOL SIDE PANEL
Qty:2

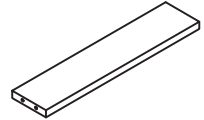

VV

STOOL LOWER SLAT
Qty:1

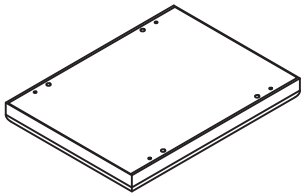

WW

SPONGE CUSHION
Qty:1

Part List

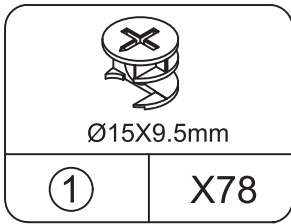

CAM LOCK
spare:3

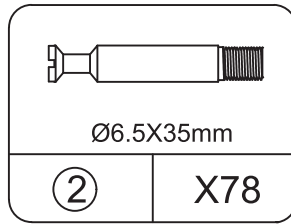

CAM BOLT
spare:3

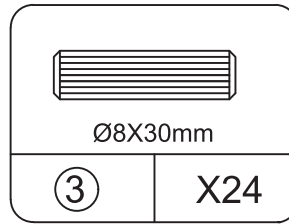

WOOD DOWEL
spare:2

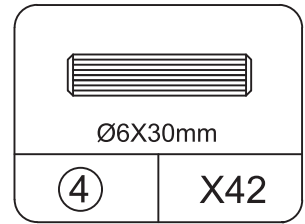

WOOD DOWEL
spare:3

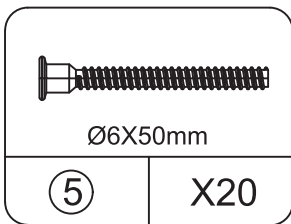

SCREW
spare:2

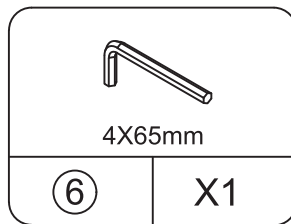

HEX KEY

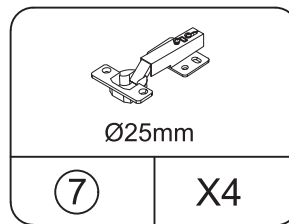

HINGE

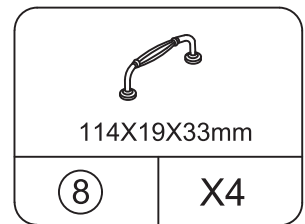

HANDLE

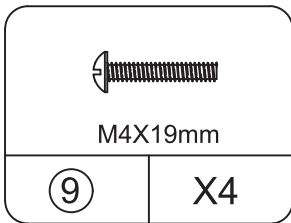

SCREW
spare:1

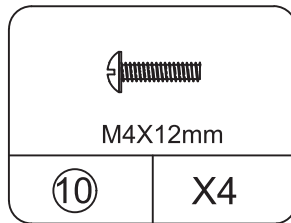

SCREW
spare:1

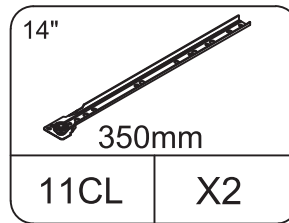

LEFT CABINET MEMBER

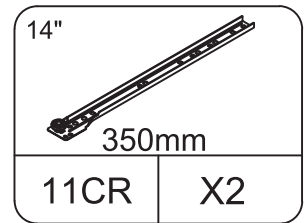

RIGHT CABINET MEMBER

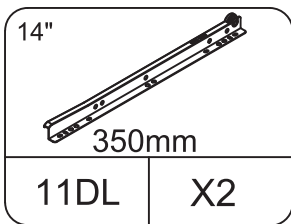

LEFT DRAWER RUNNER

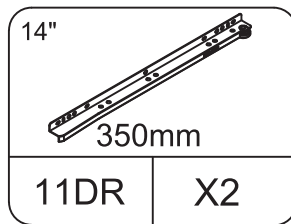

RIGHT DRAWER RUNNER

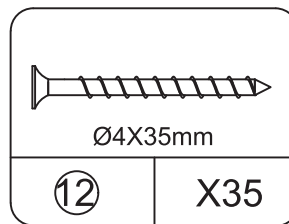

SCREW
spare:3

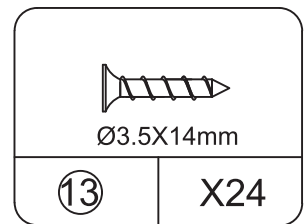

SCREW
spare:2

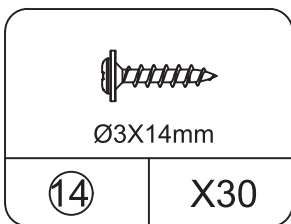

SCREW
spare:2

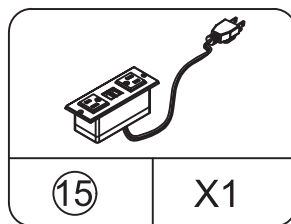

POWER STRIP

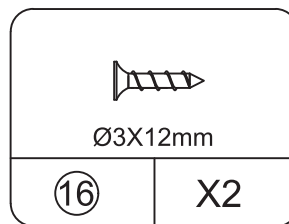

SCREW
spare:1

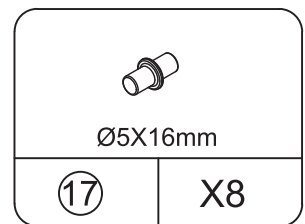

SHELF SUPPORT
spare:1

Part List

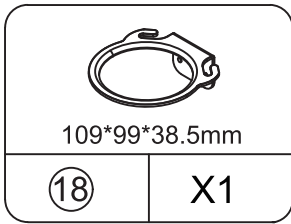

HAIR DRYER RACK

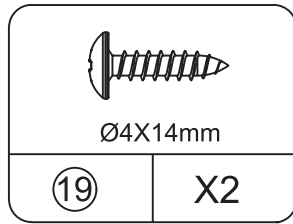

SCREW
spare:1

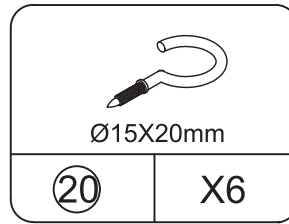

HOOKING
spare:1

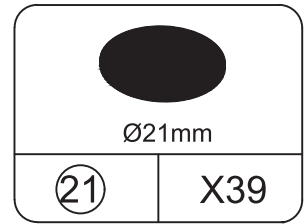

PERFECT STICKER
spare:3

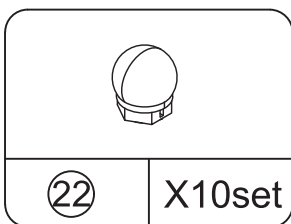

LIGHT BULB

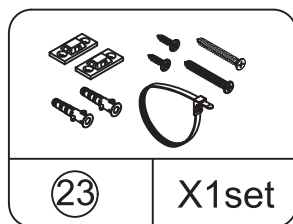

HIPPING RESTRAINT
HARDWARE KIT

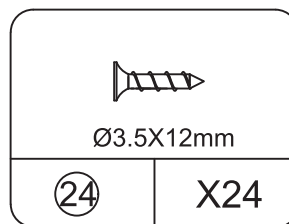

SCREW
spare:2

Cam Lock Fastening System

⚠ Insert the cam bolt into the hole first, then insert the cam lock and lock it.

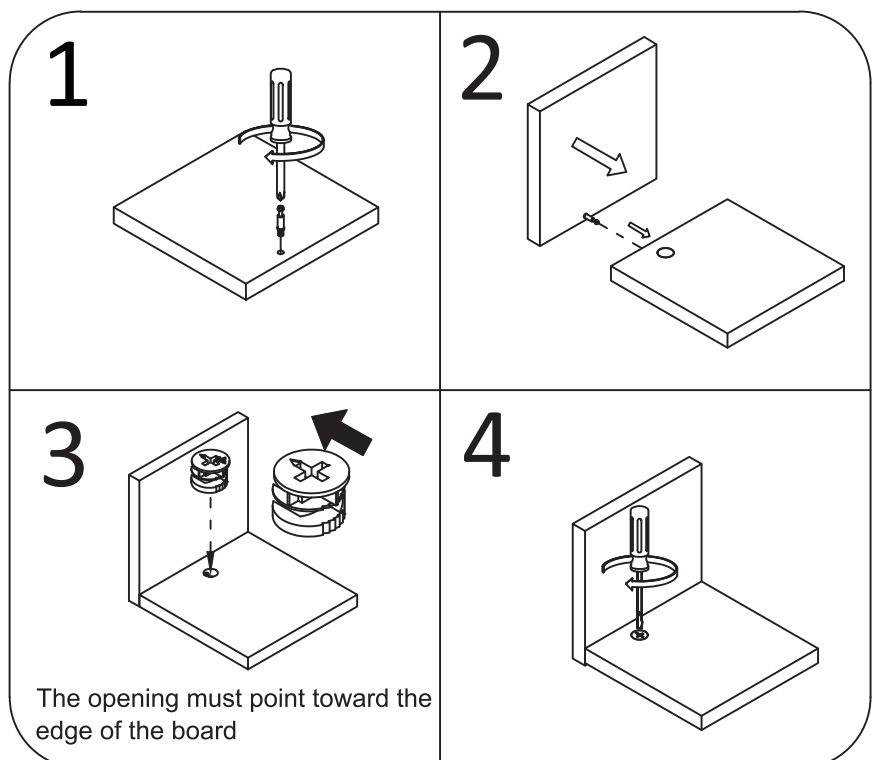

PARTS LIST

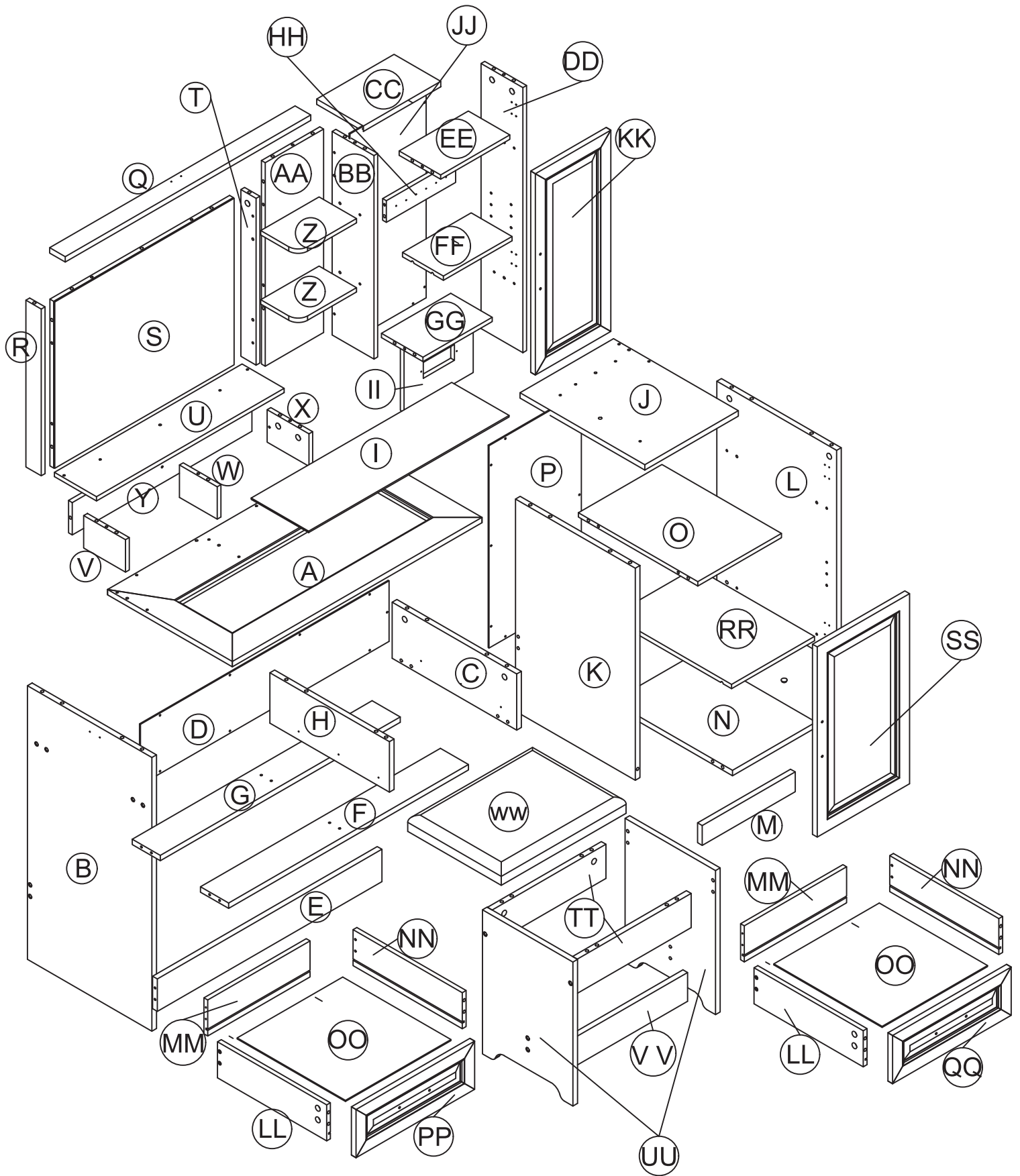

STEP1

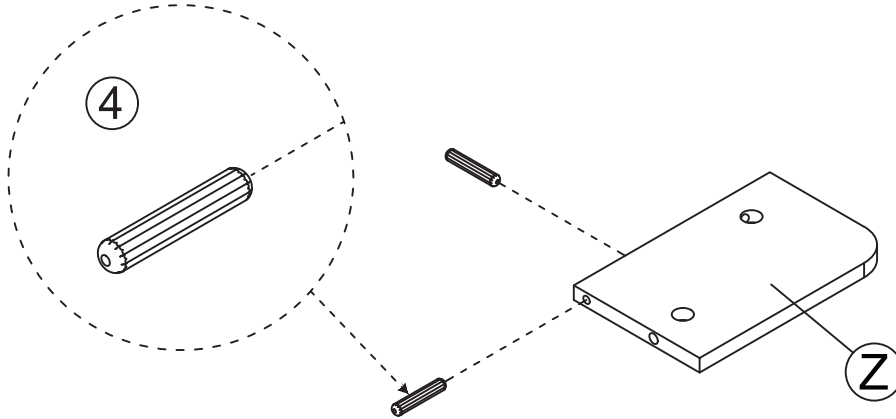
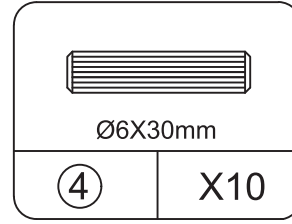
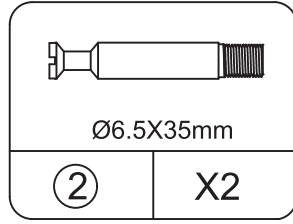
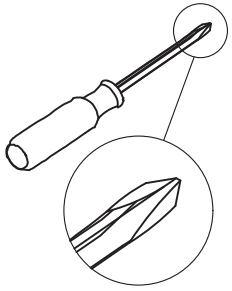

X2

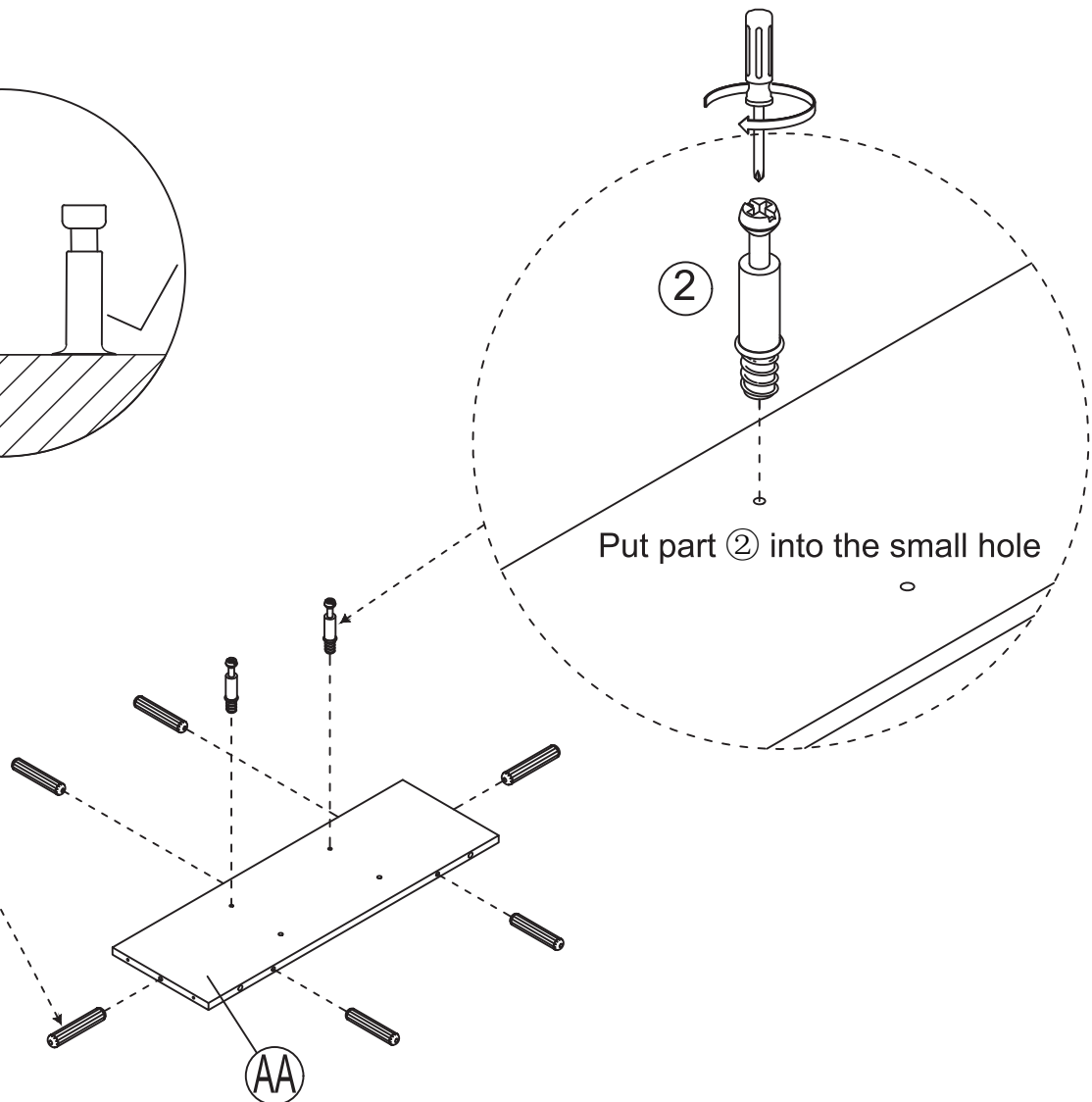
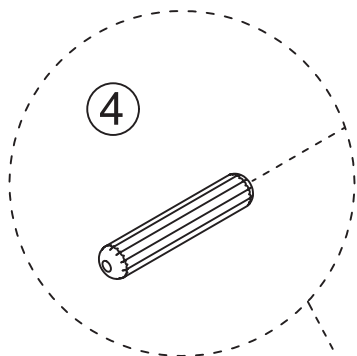
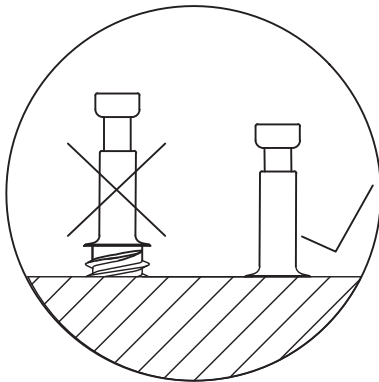

STEP 2

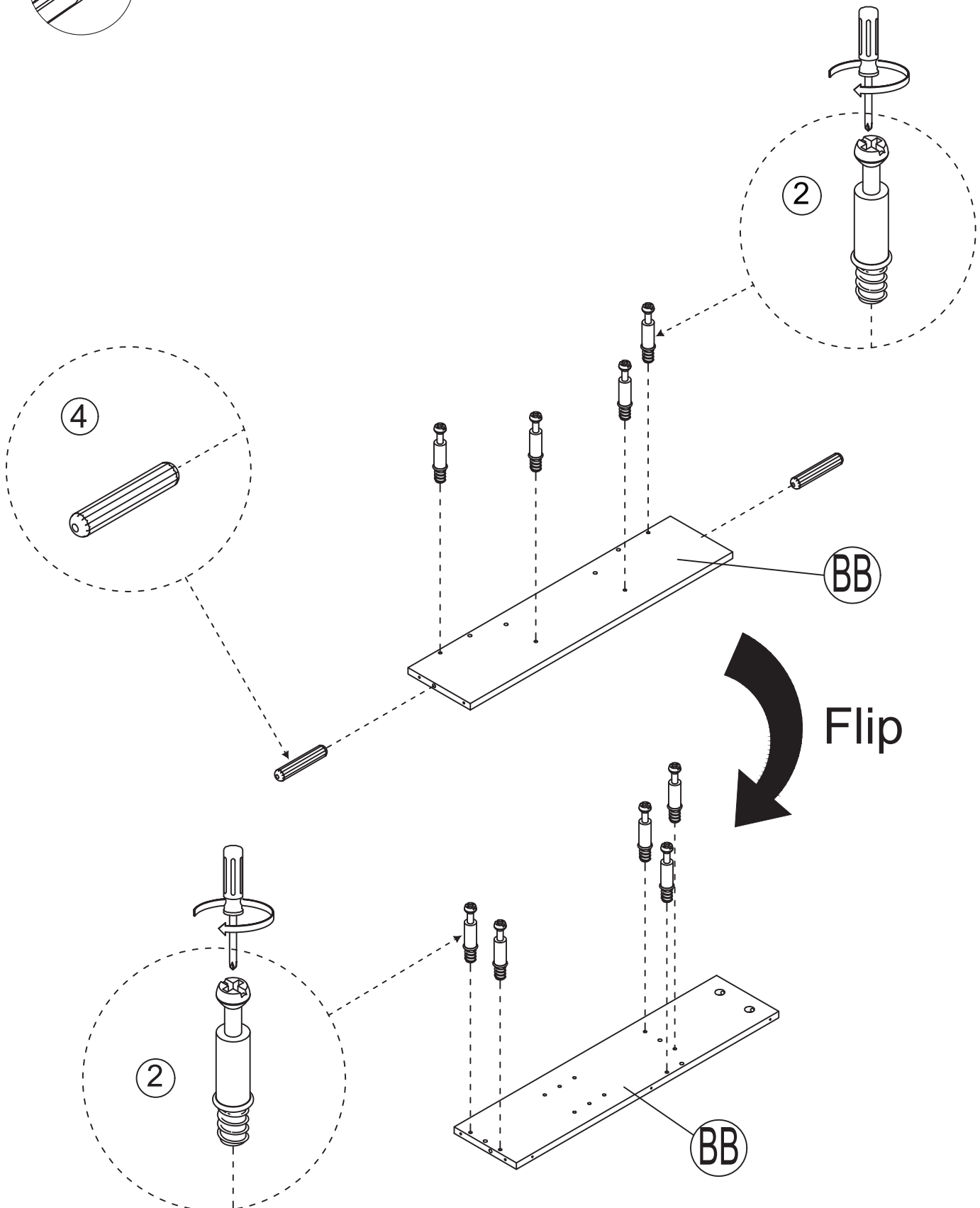
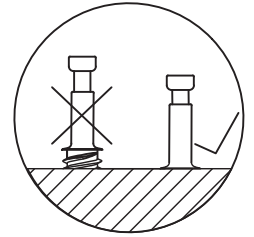
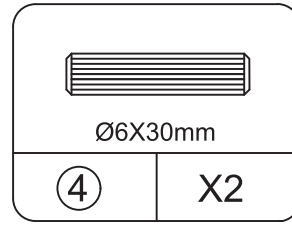
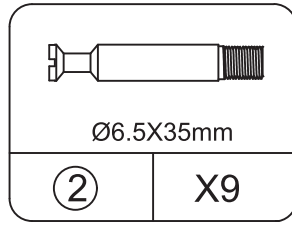
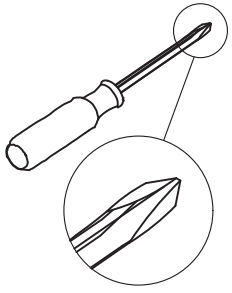

STEP 3

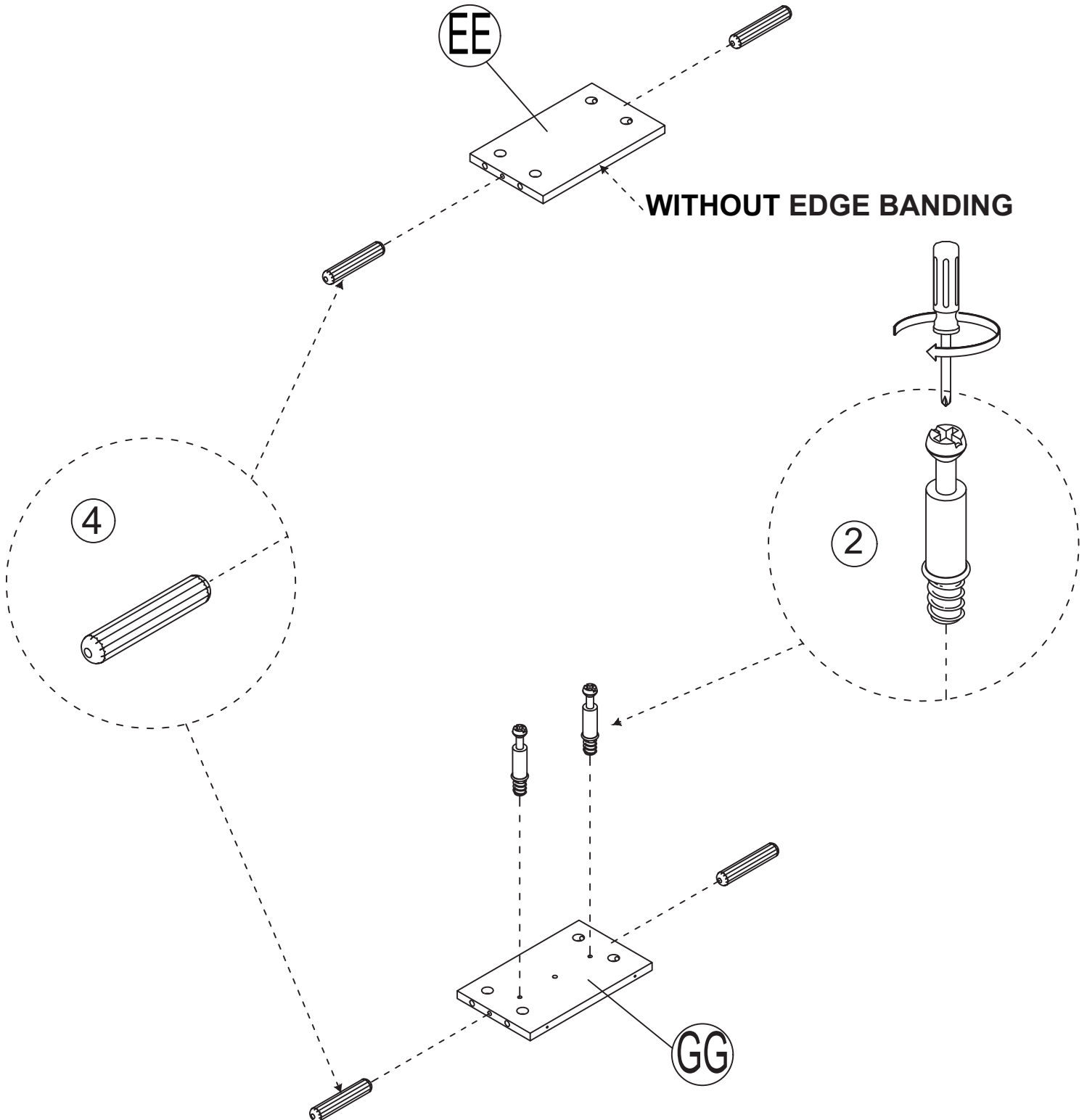
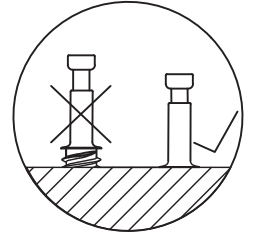
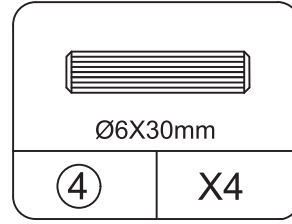
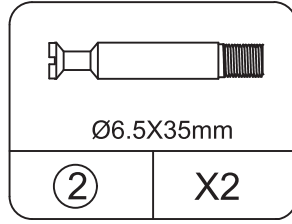
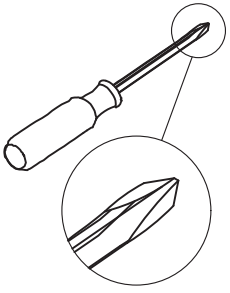

STEP 4

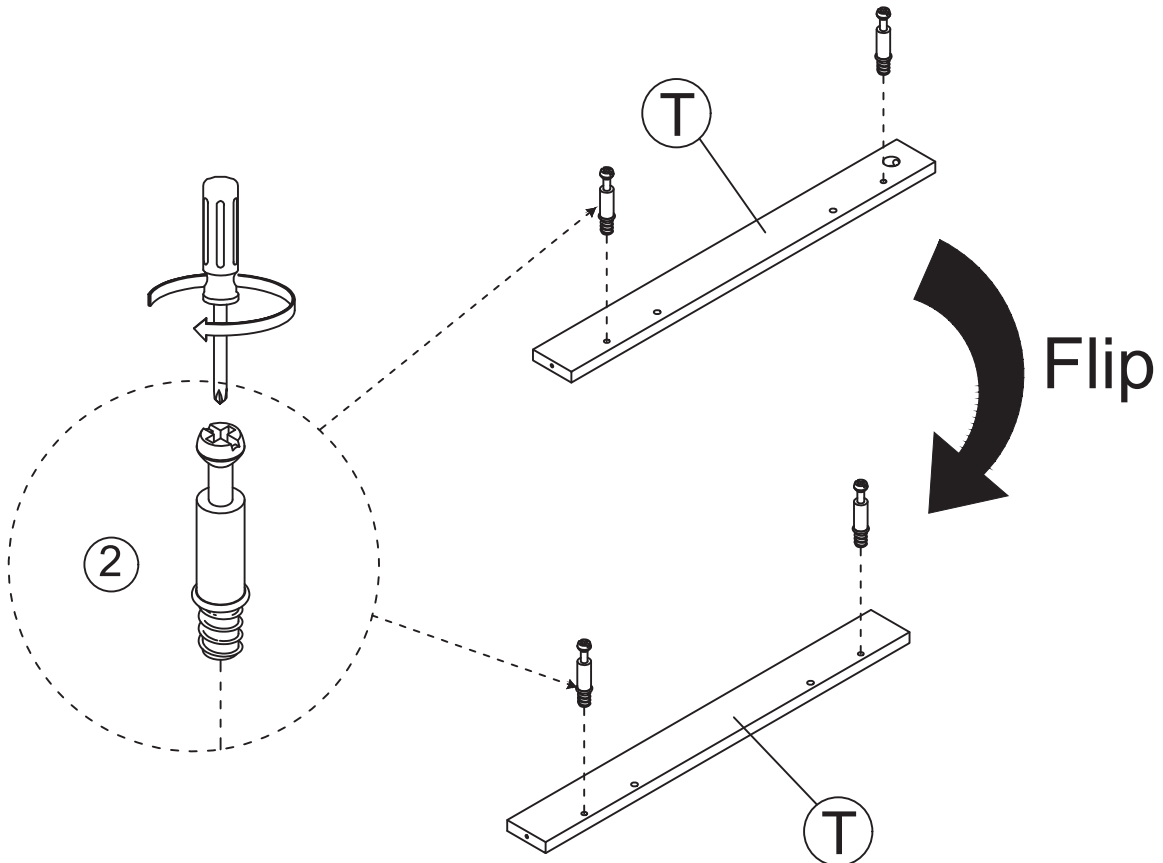
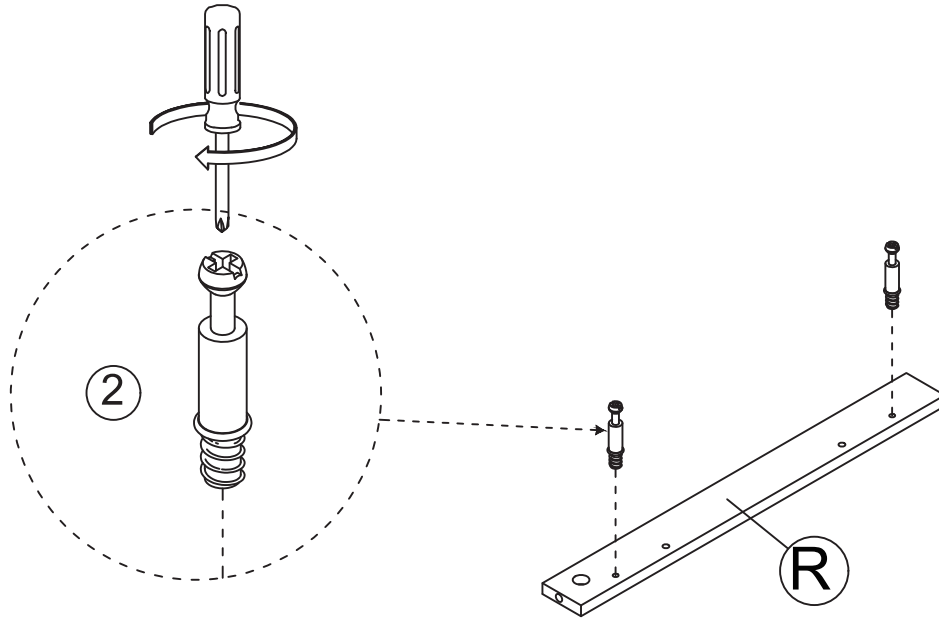
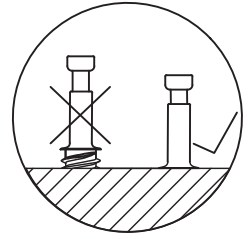
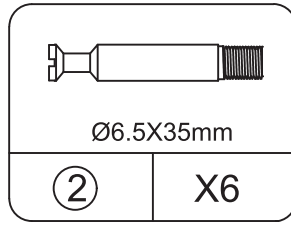
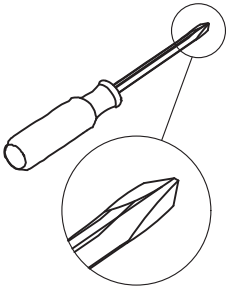

STEP 5

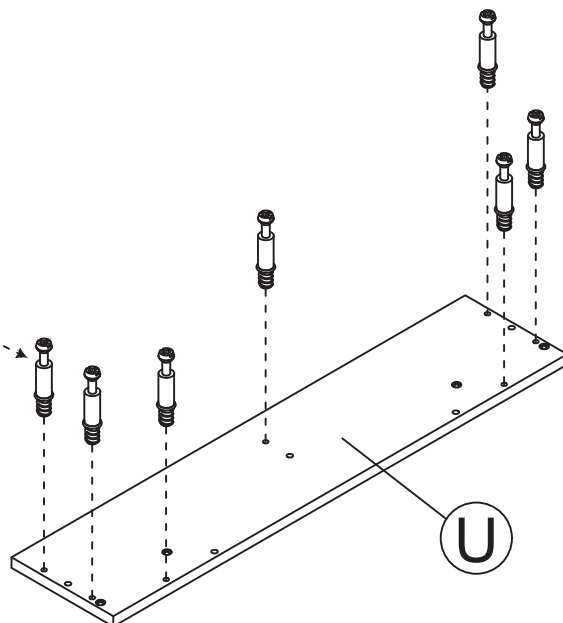
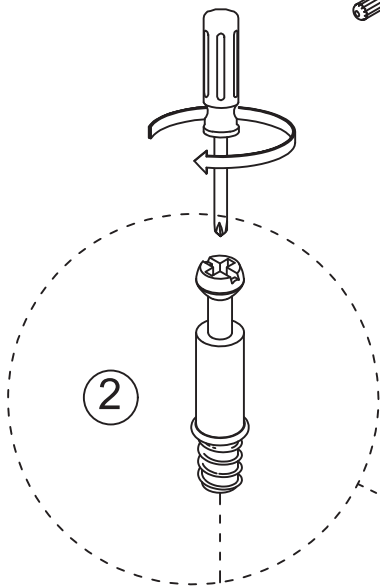
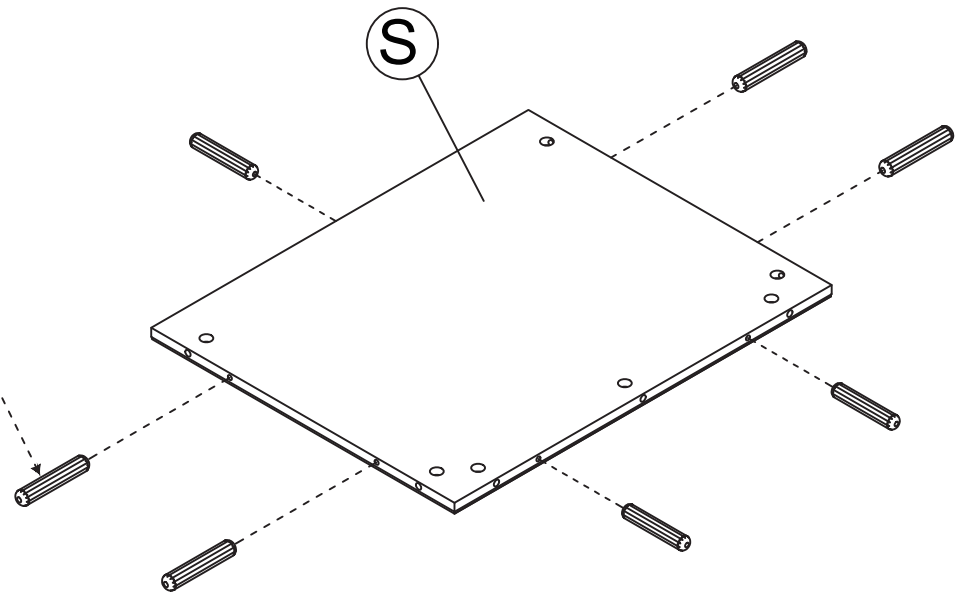
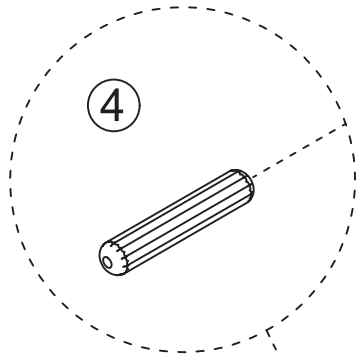
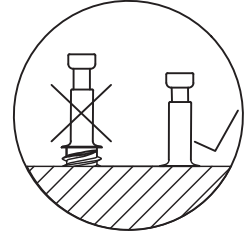
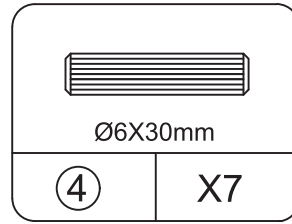
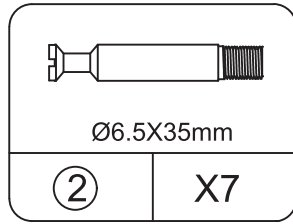
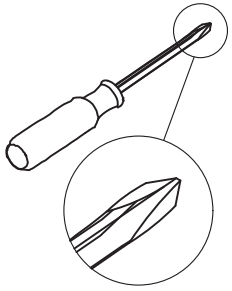

STEP 6

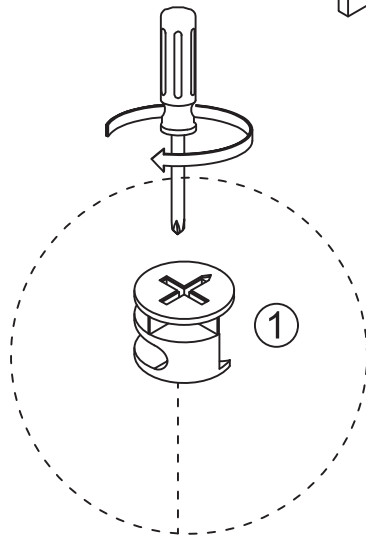
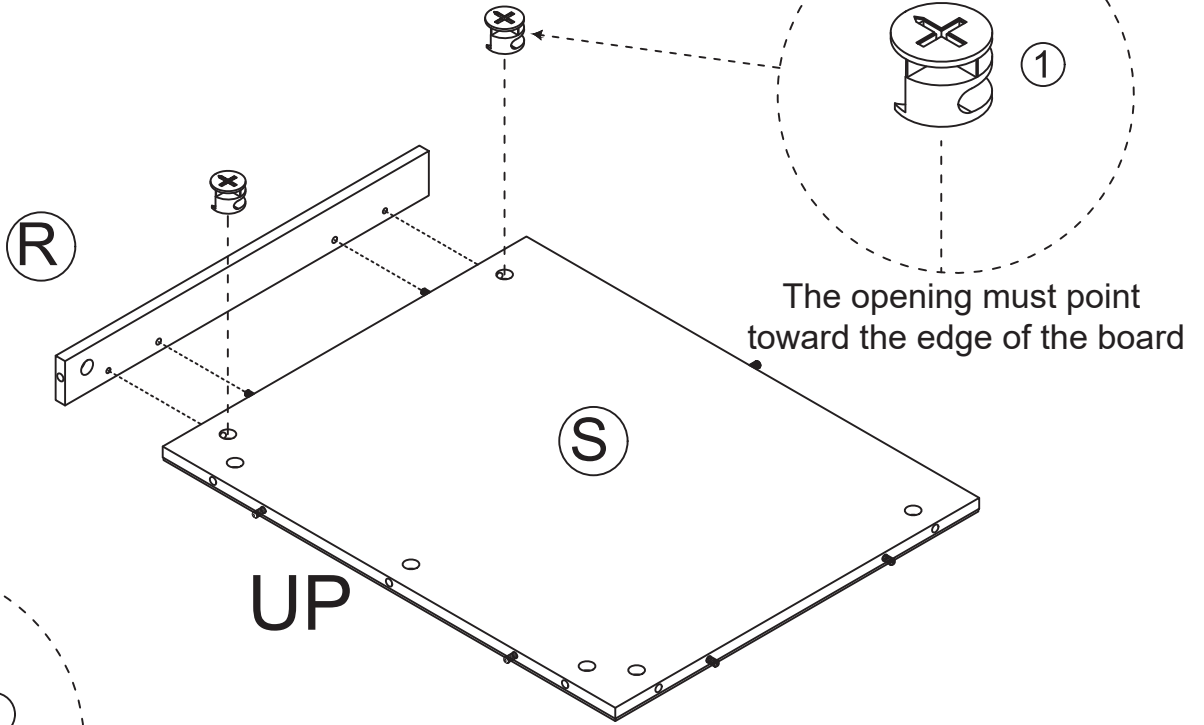
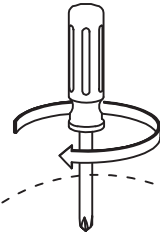
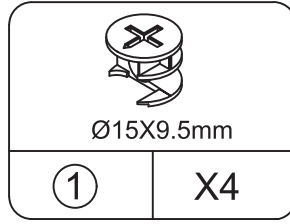
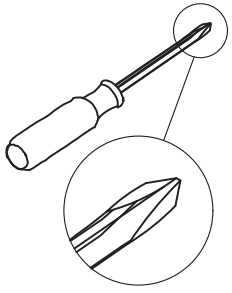

The opening must point toward the edge of the board

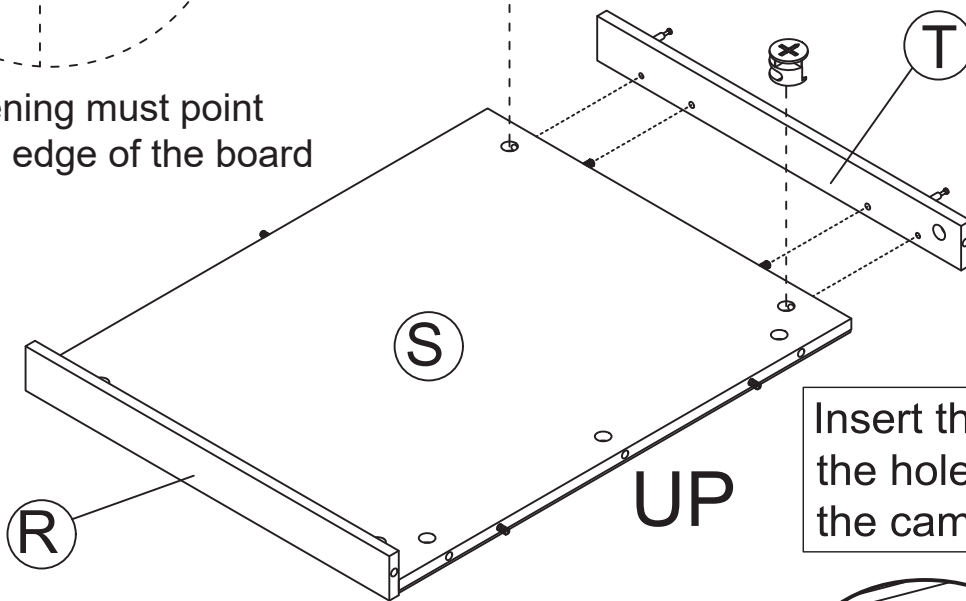

Insert the cam bolt into the hole first, then insert the cam lock and lock it.

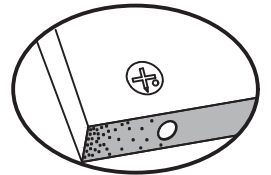

Proper orientation of CAM LOCK

STEP 7

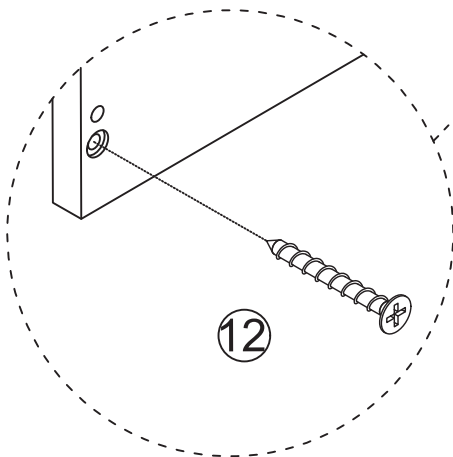
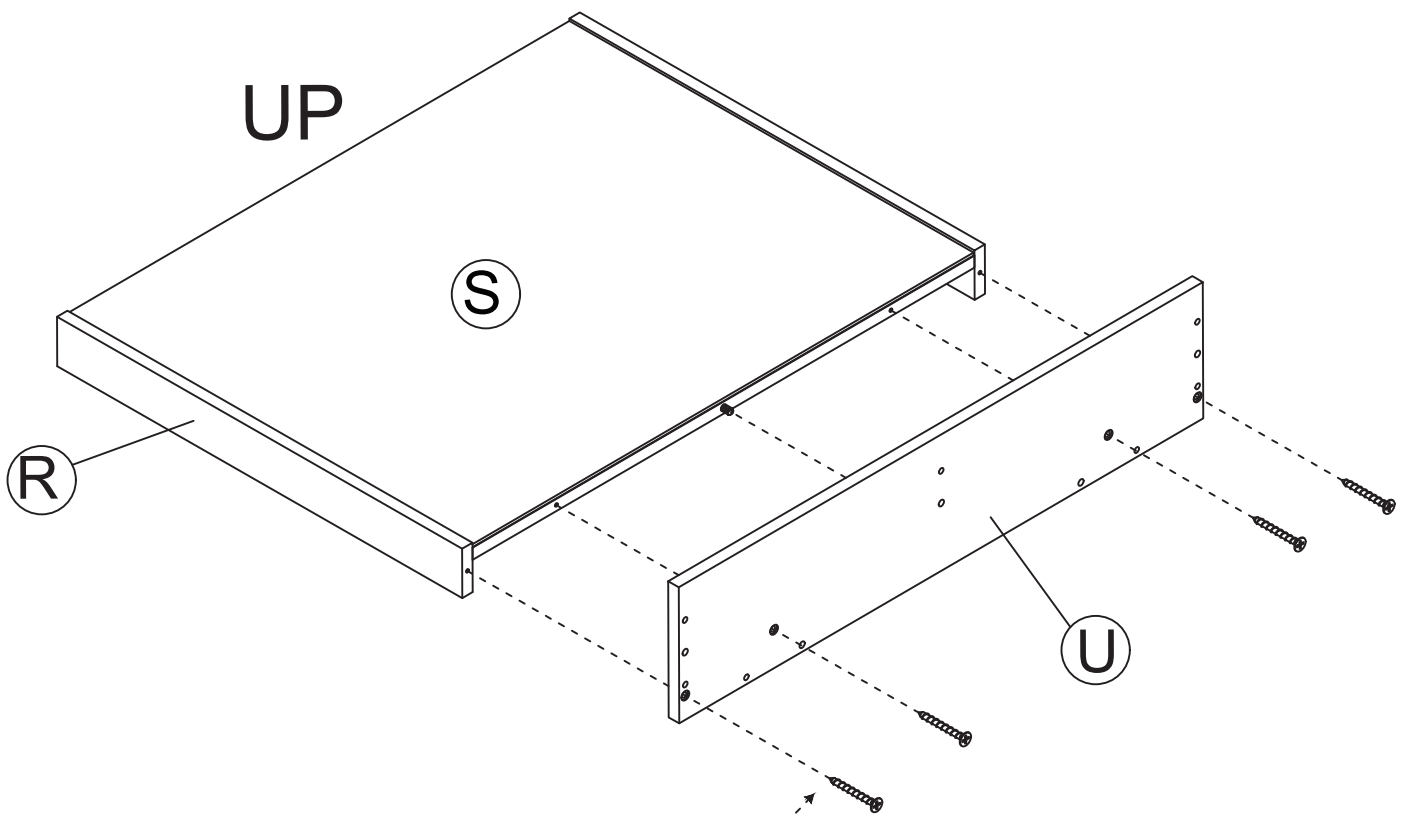
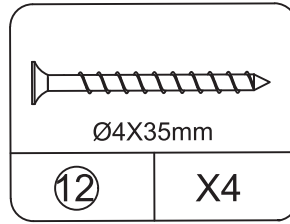
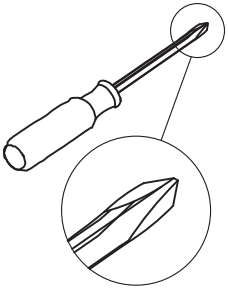

STEP8

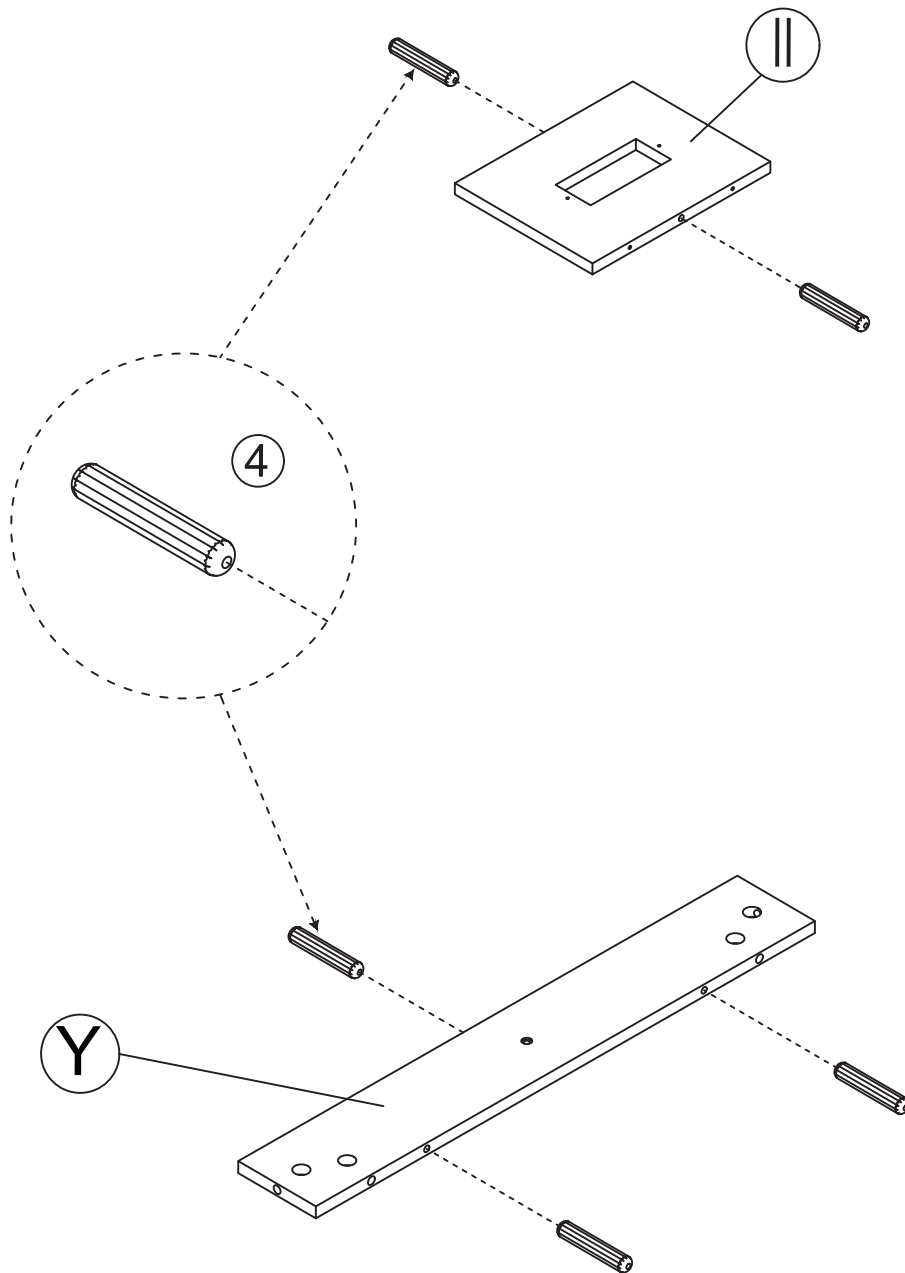
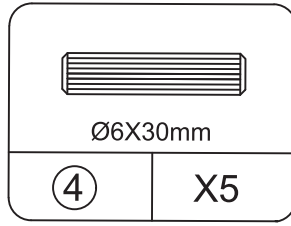
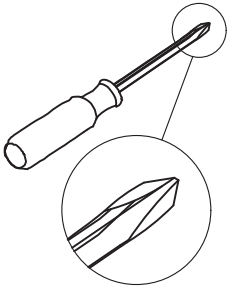

STEP9

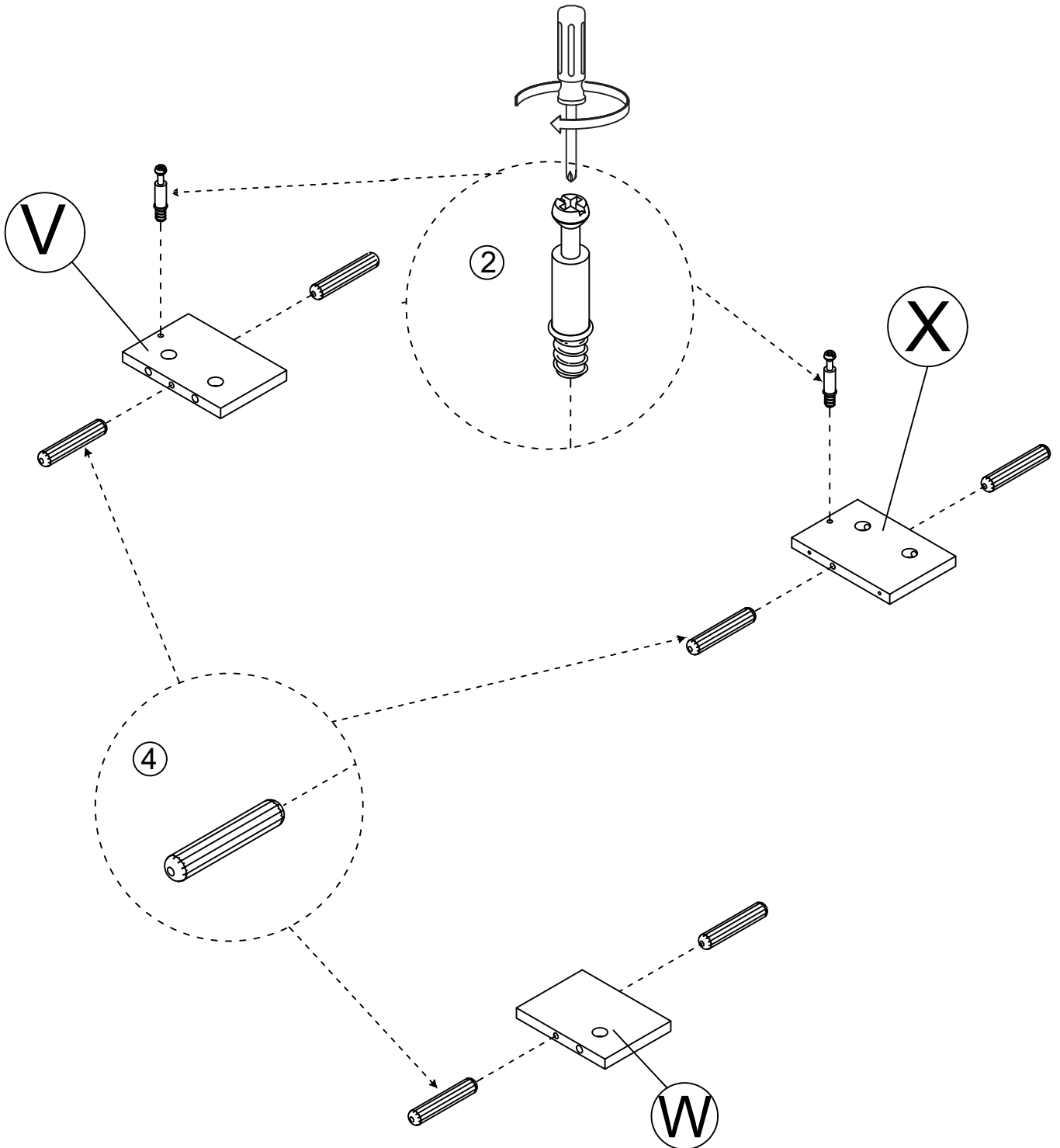
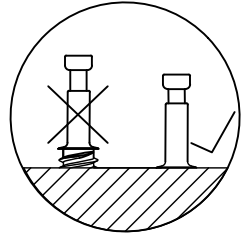
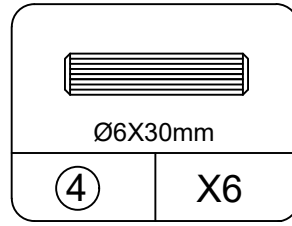
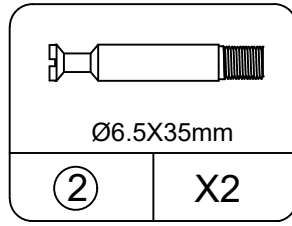
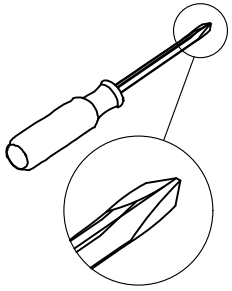

STEP10

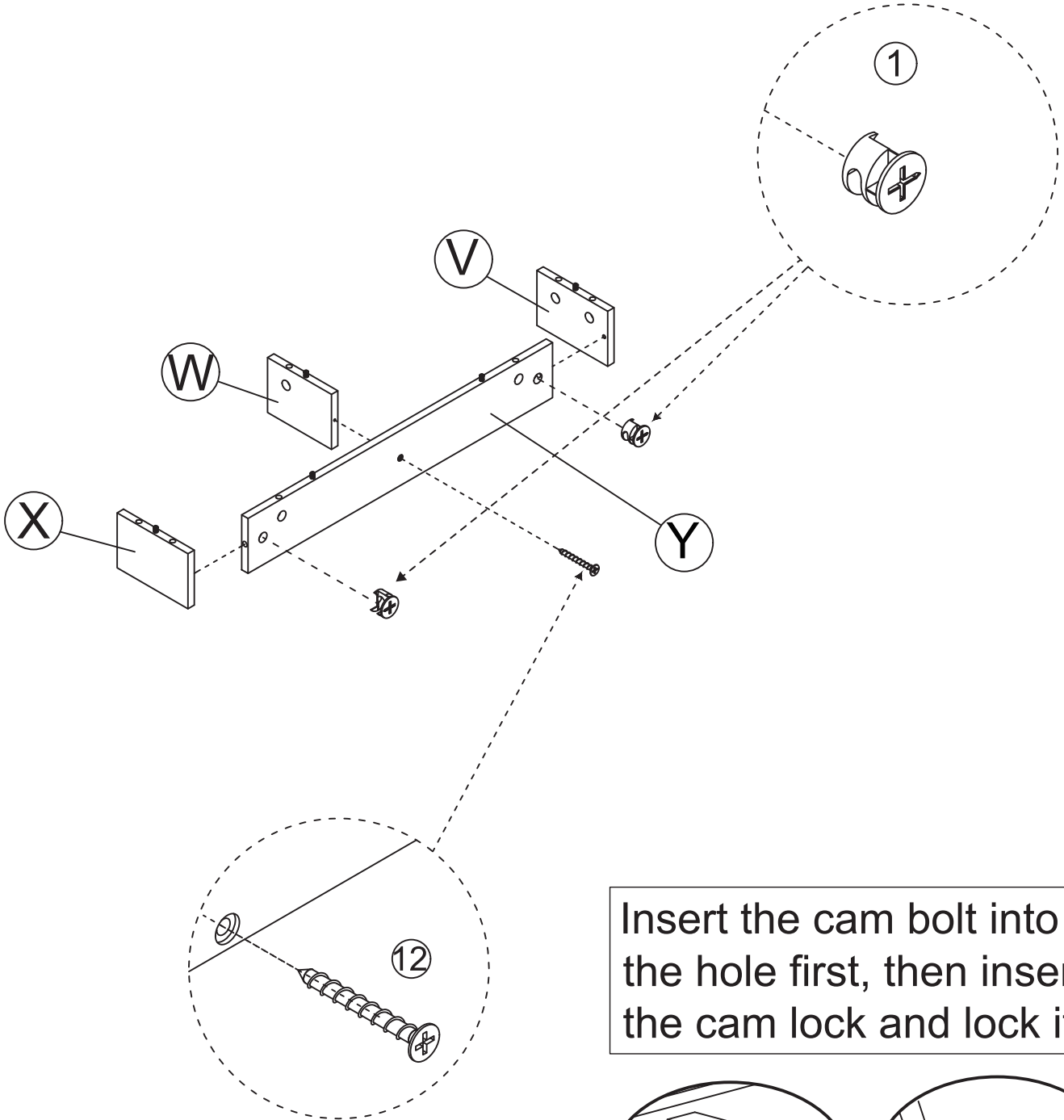
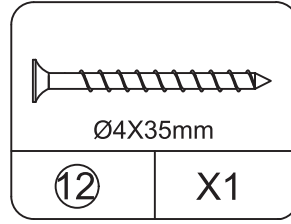
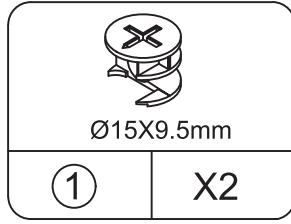
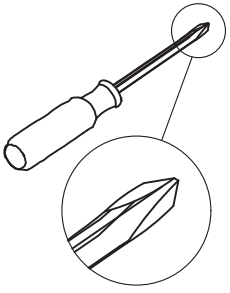

Insert the cam bolt into the hole first, then insert the cam lock and lock it.

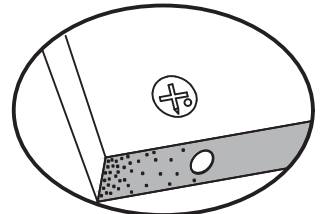

Proper orientation of CAM LOCK

STEP11

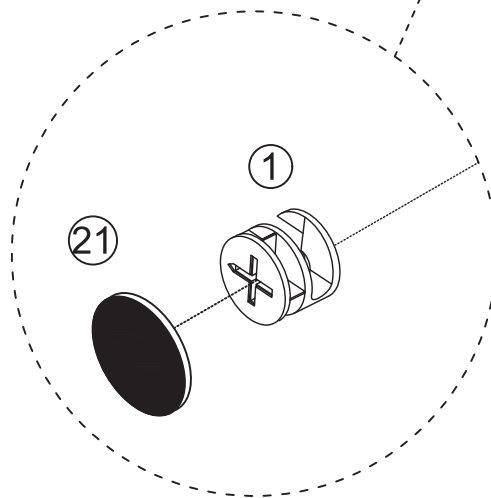
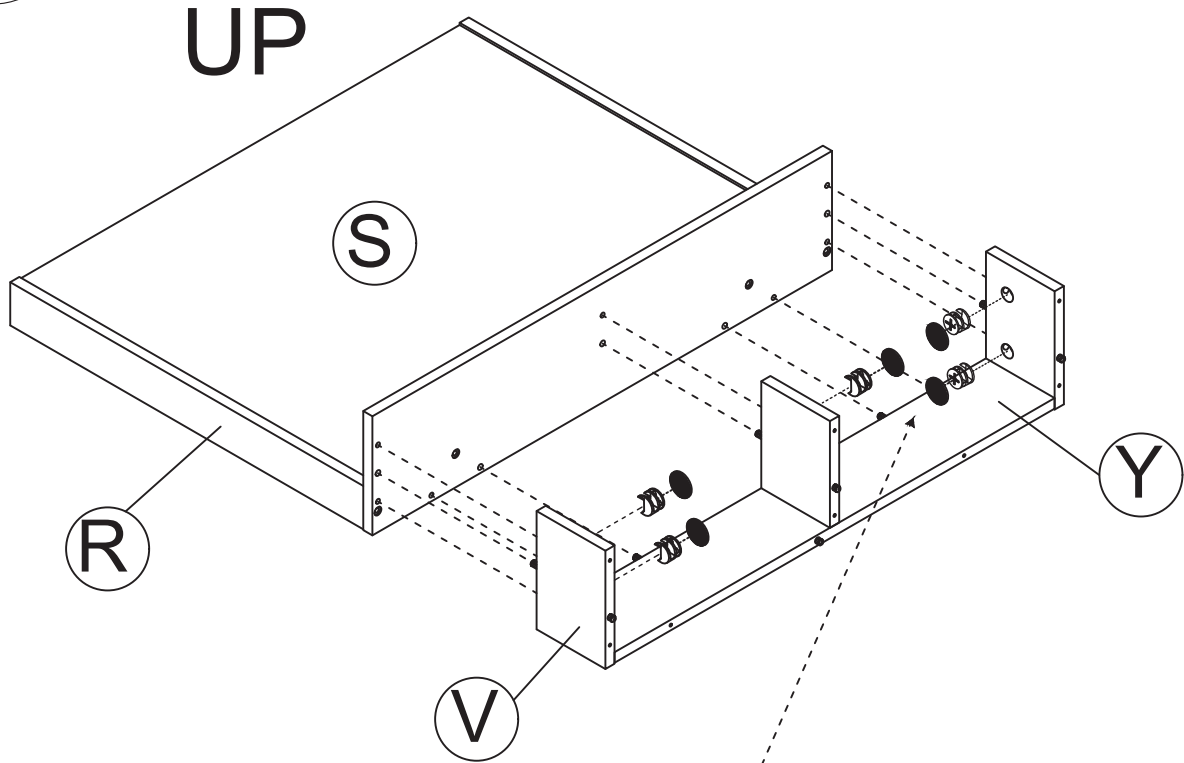
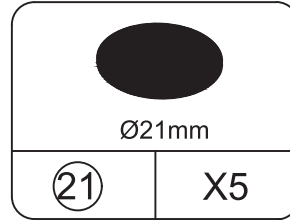
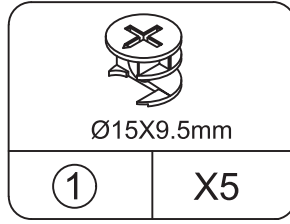
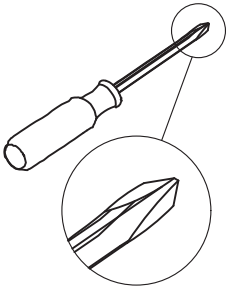

Lock first

Insert the cam bolt into the hole first, then insert the cam lock and lock it.

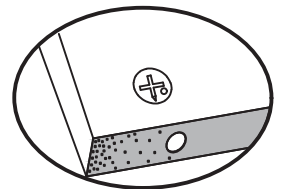

Proper orientation of CAM LOCK

STEP12

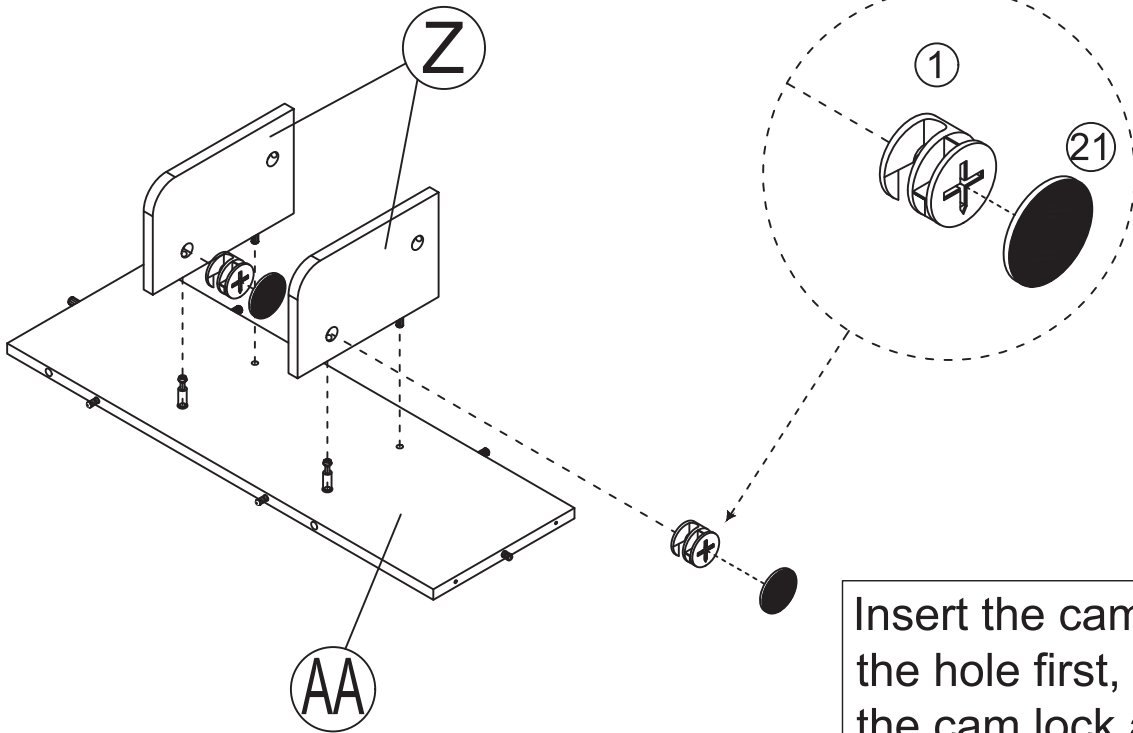
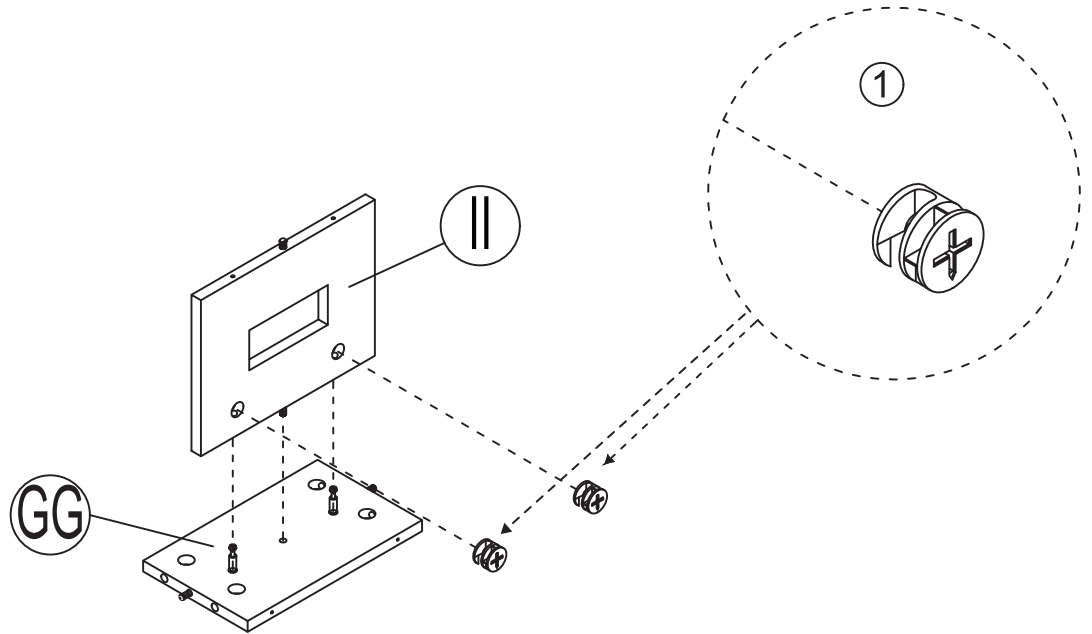
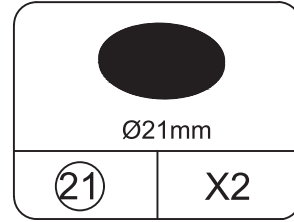
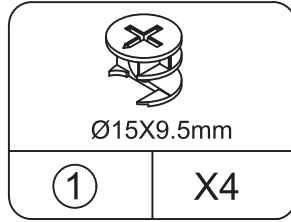
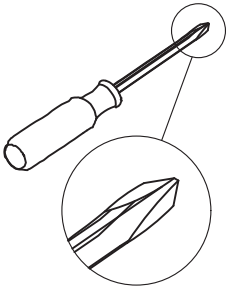

Insert the cam bolt into the hole first, then insert the cam lock and lock it.

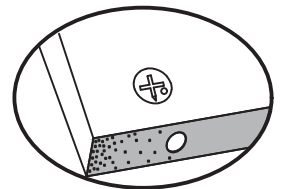

Proper orientation of CAM LOCK

STEP13

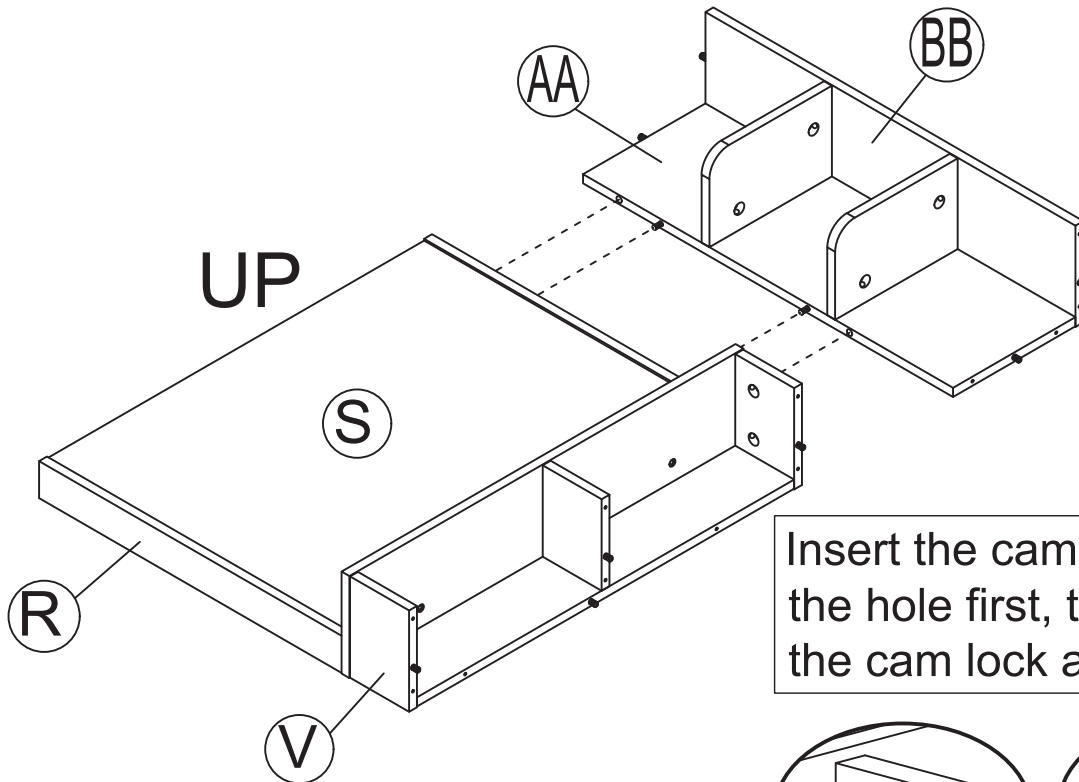
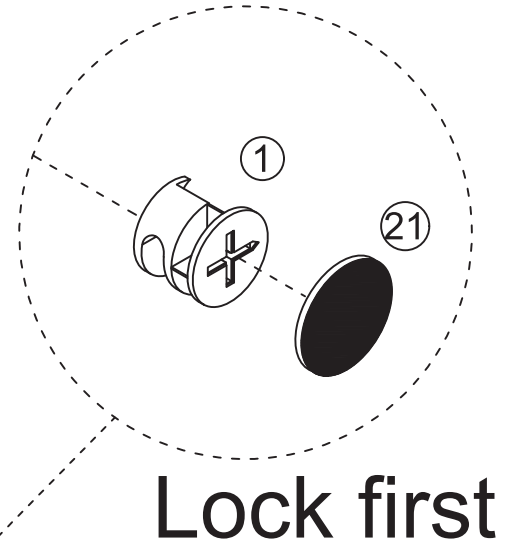
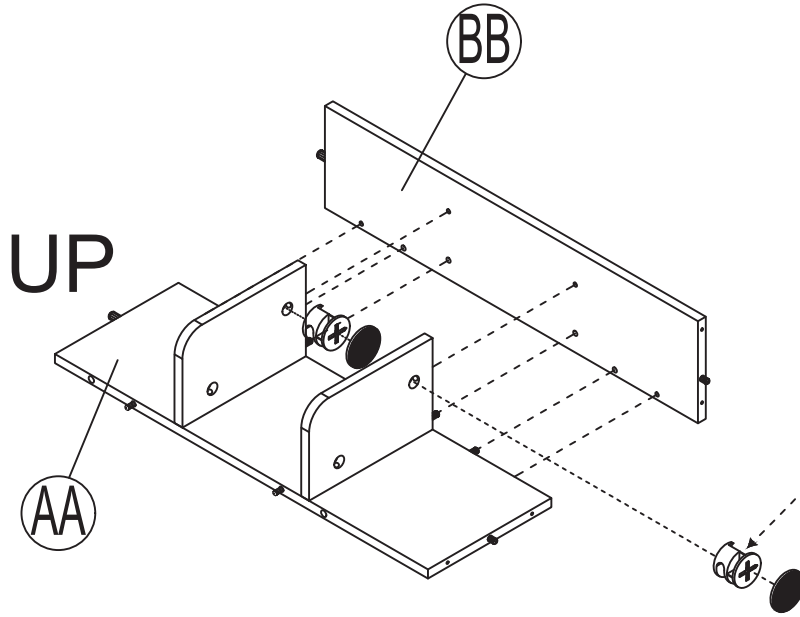
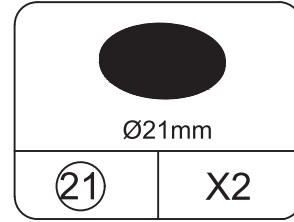
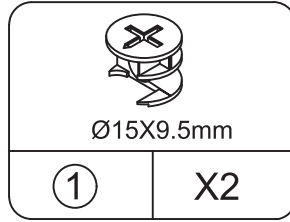
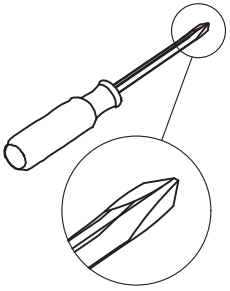

Insert the cam bolt into the hole first, then insert the cam lock and lock it.

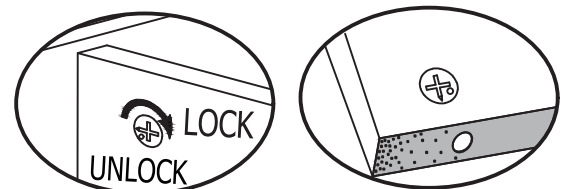

Proper orientation of CAM LOCK

STEP14

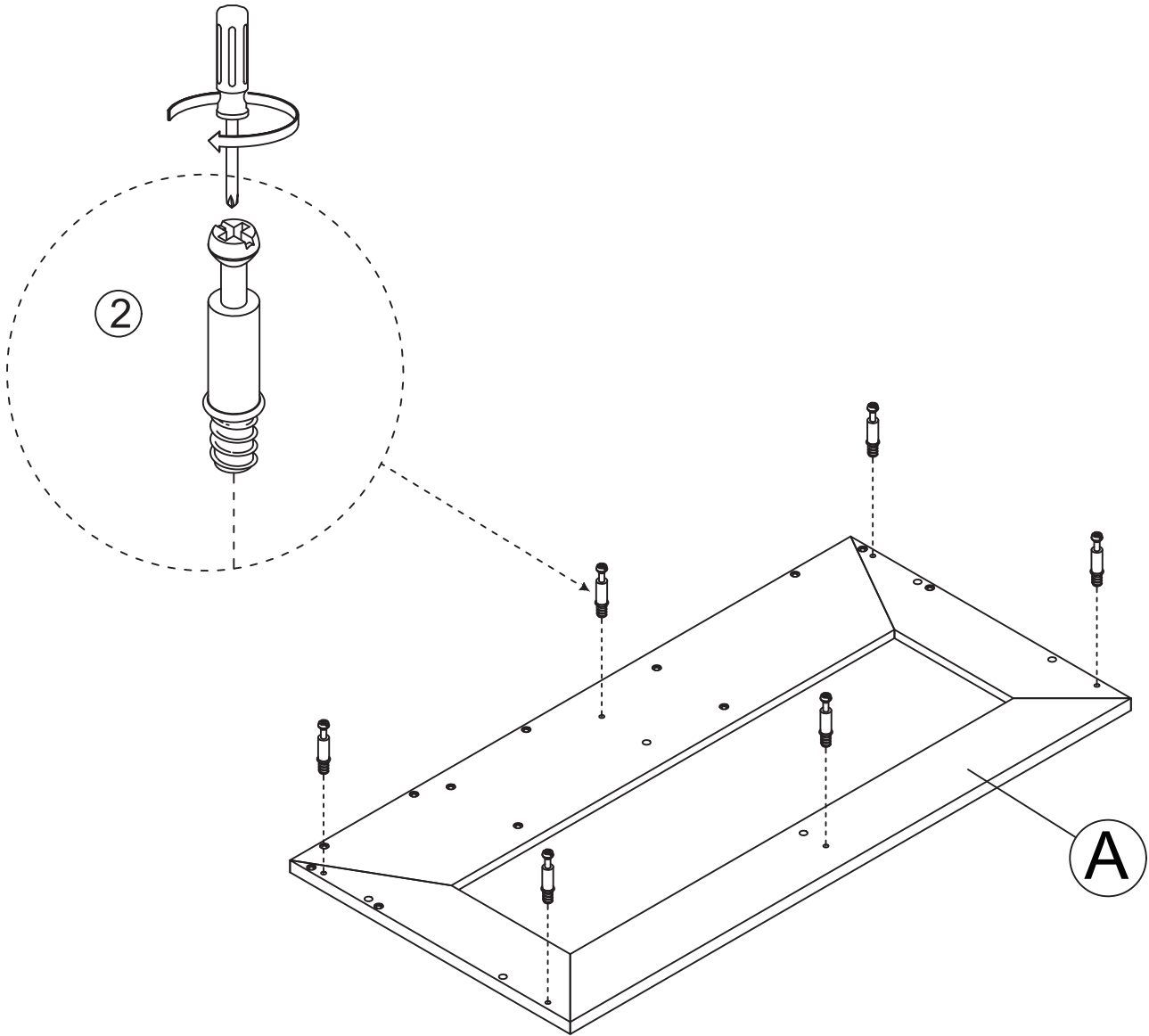
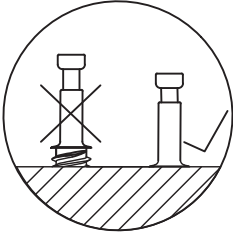
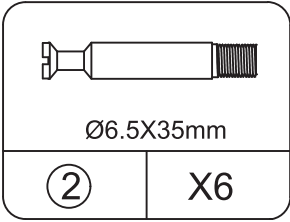
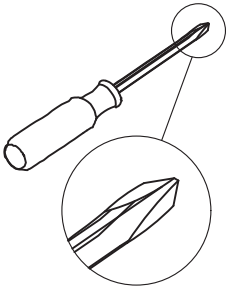

STEP 15

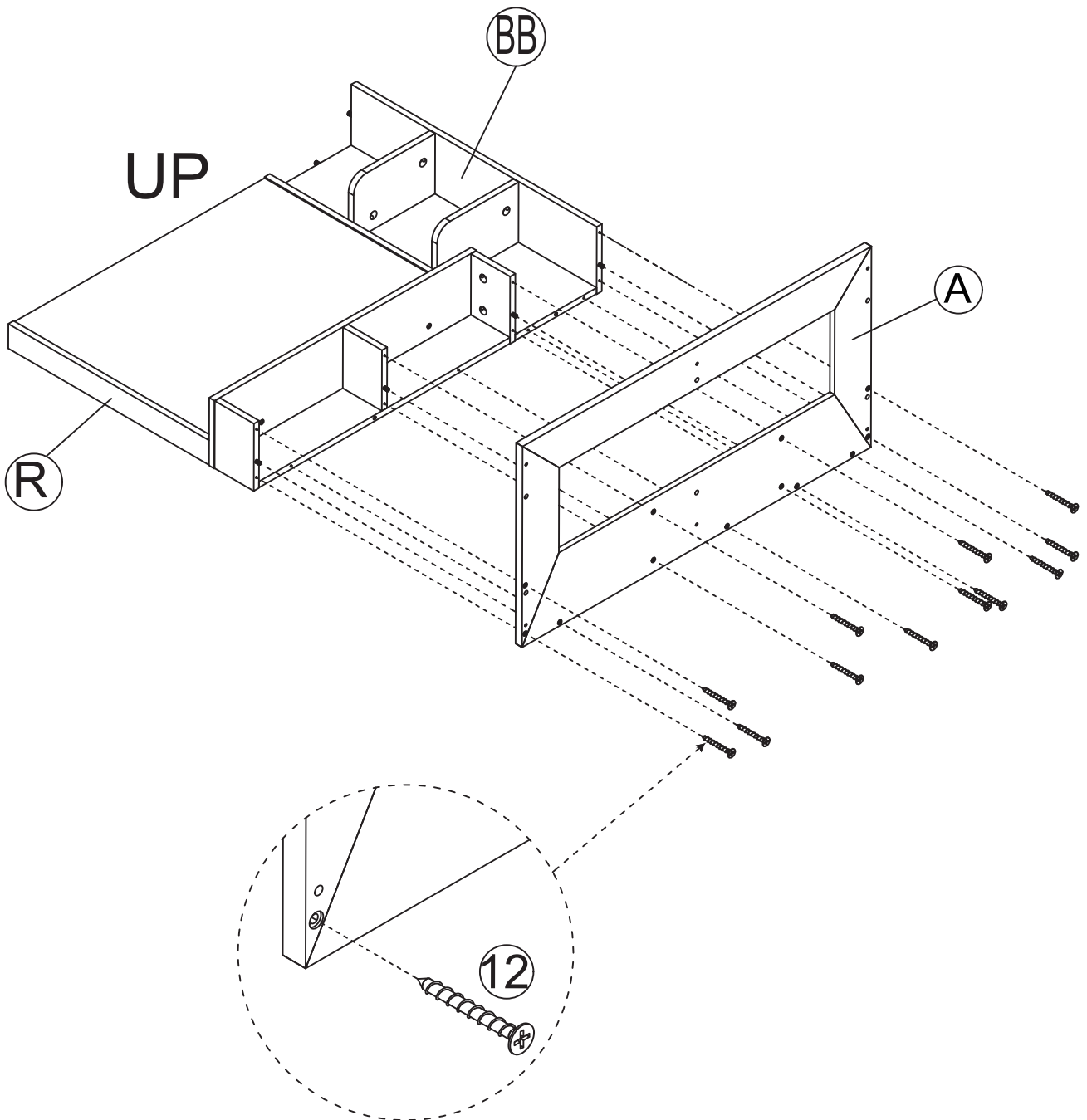
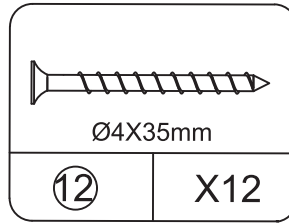
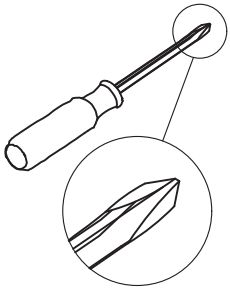

STEP16

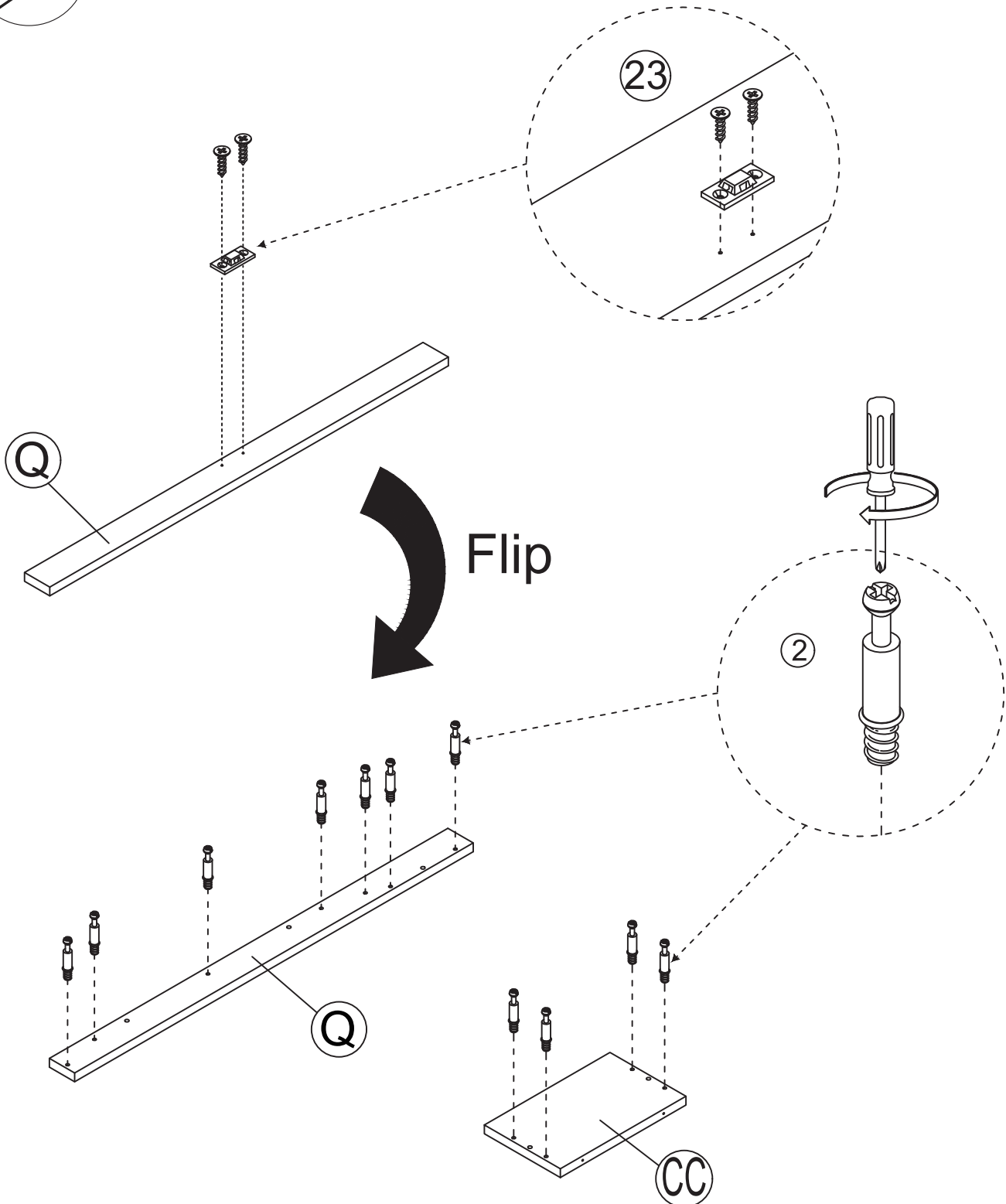
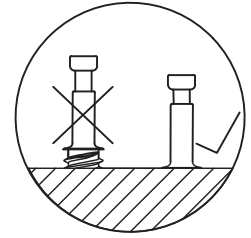
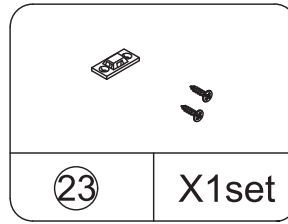
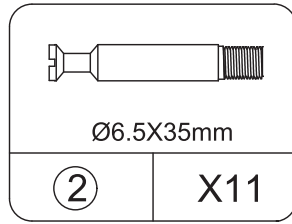
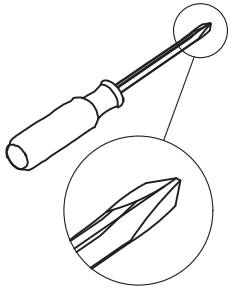

STEP17

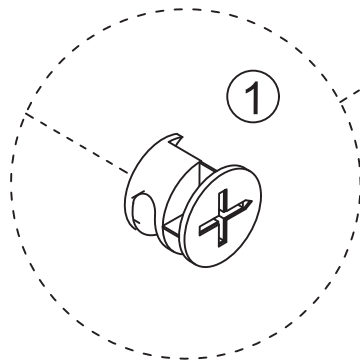
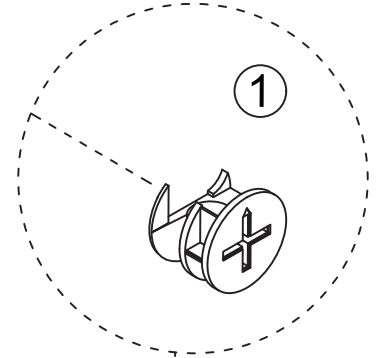
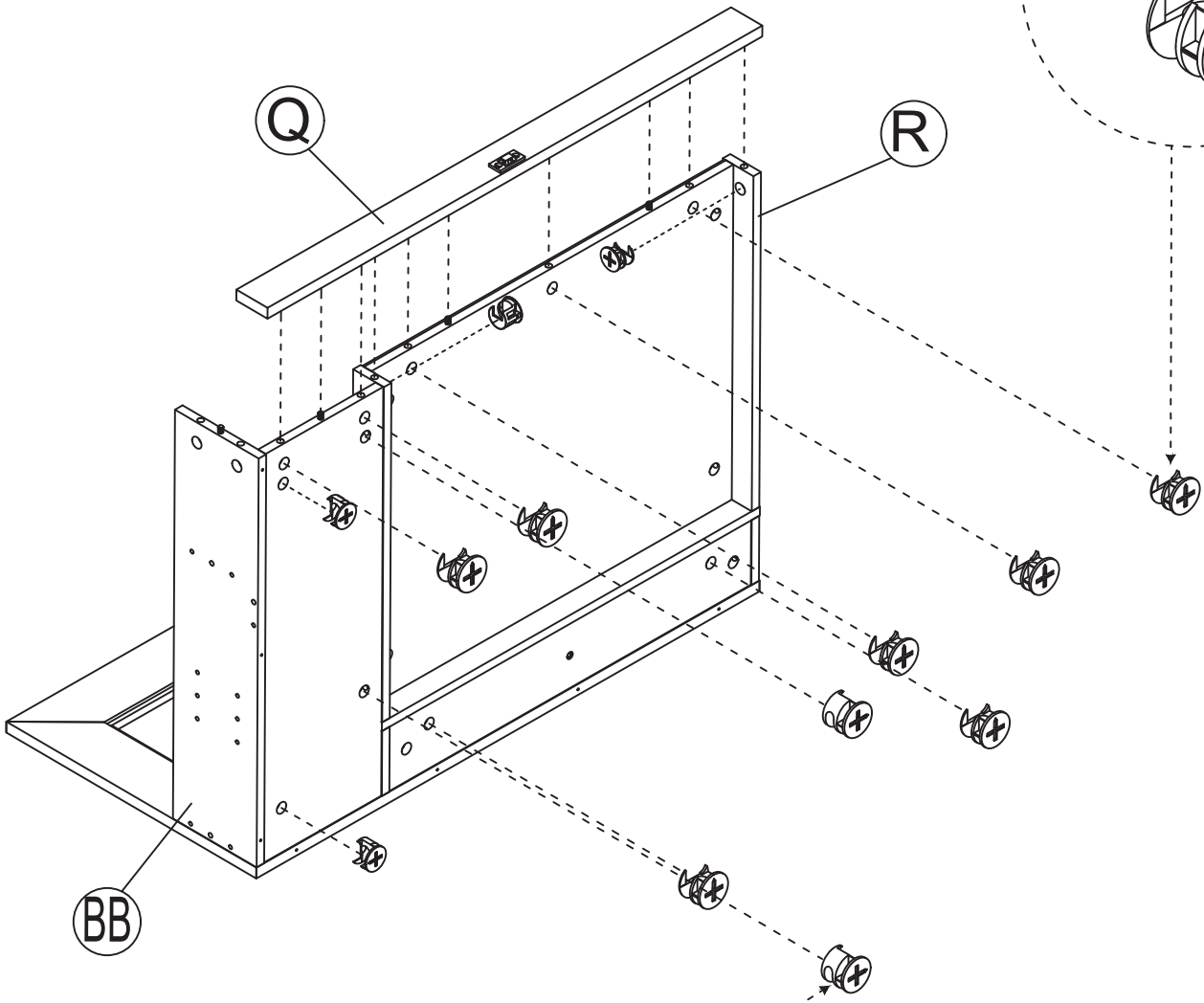
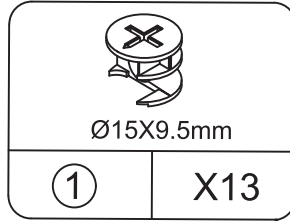
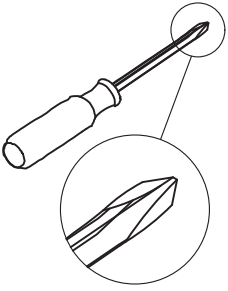

Insert the cam bolt into the hole first, then insert the cam lock and lock it.

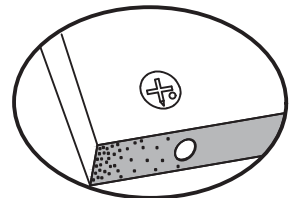

Proper orientation of CAM LOCK

STEP18

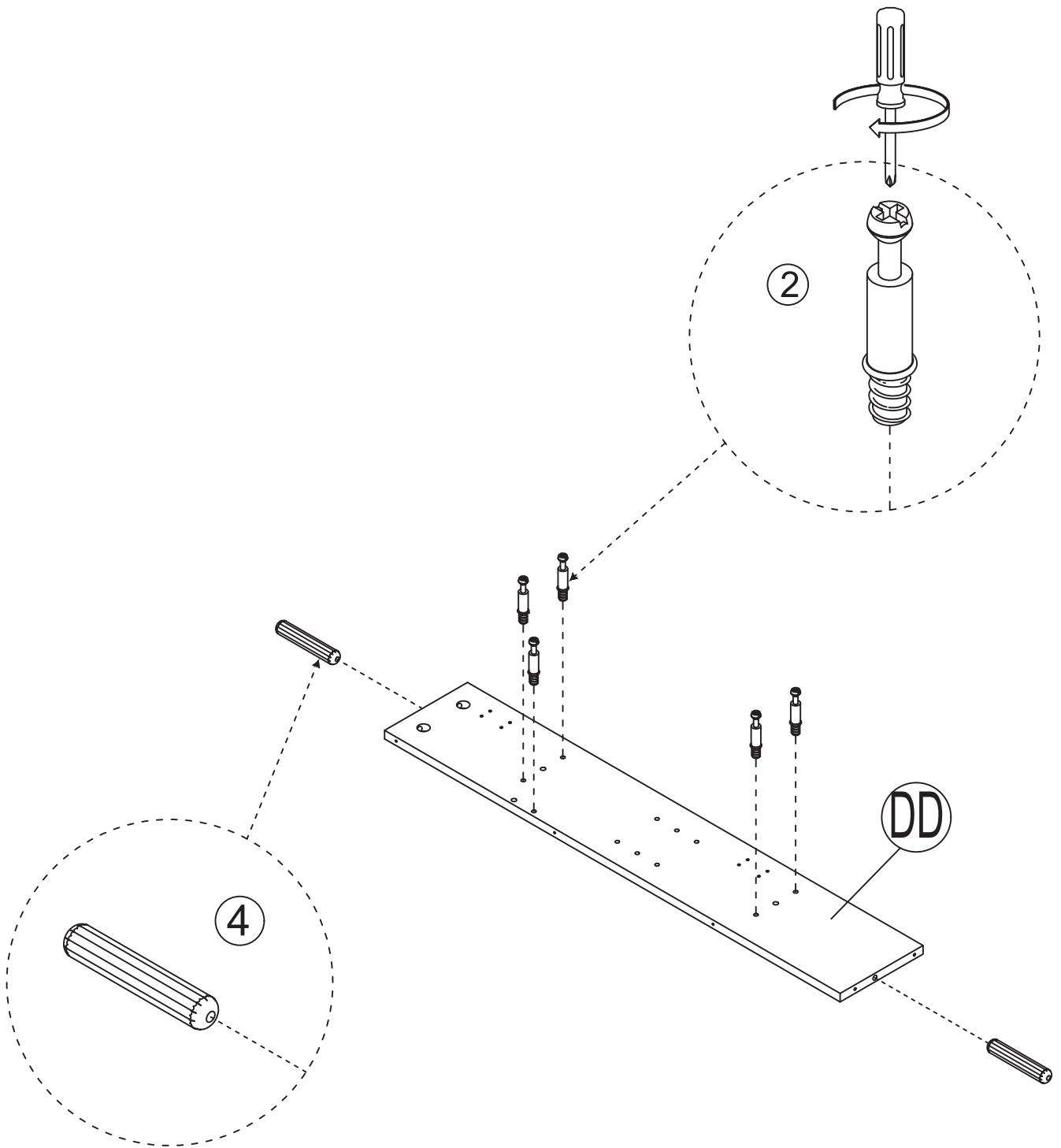
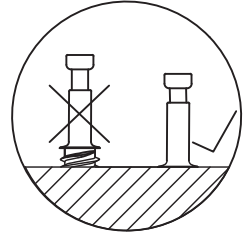
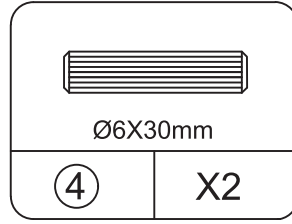
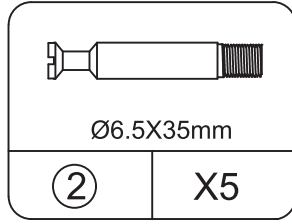
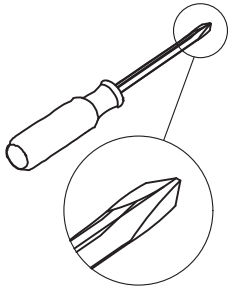

STEP19

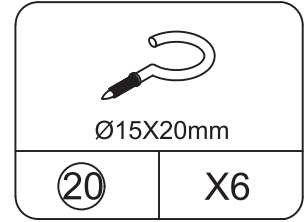
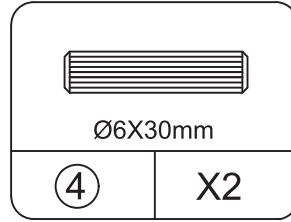
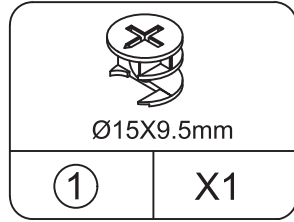
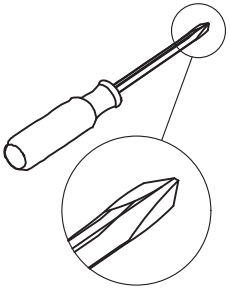

WITHOUT EDGE BANDING

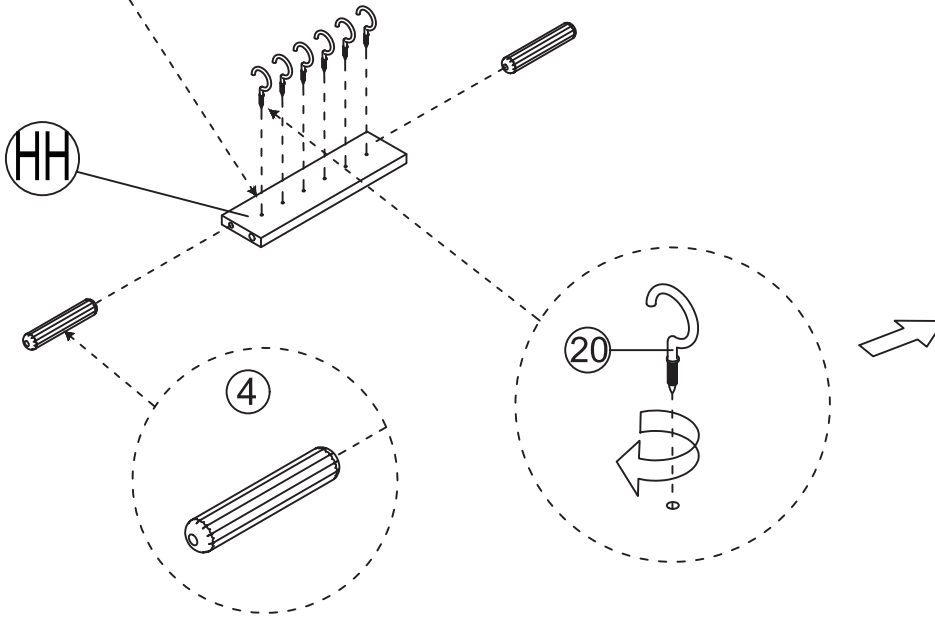

THE RIGHT DIRECTION

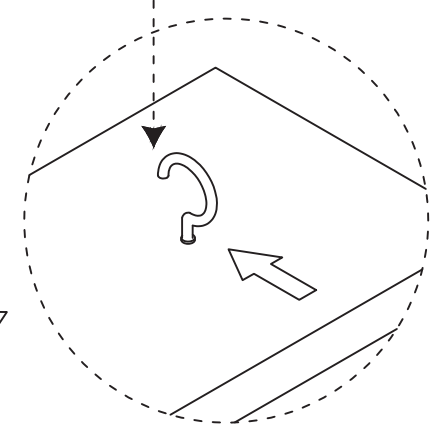

FINISH

No. 24 hardware
completion direction

WITHOUT EDGE BANDING

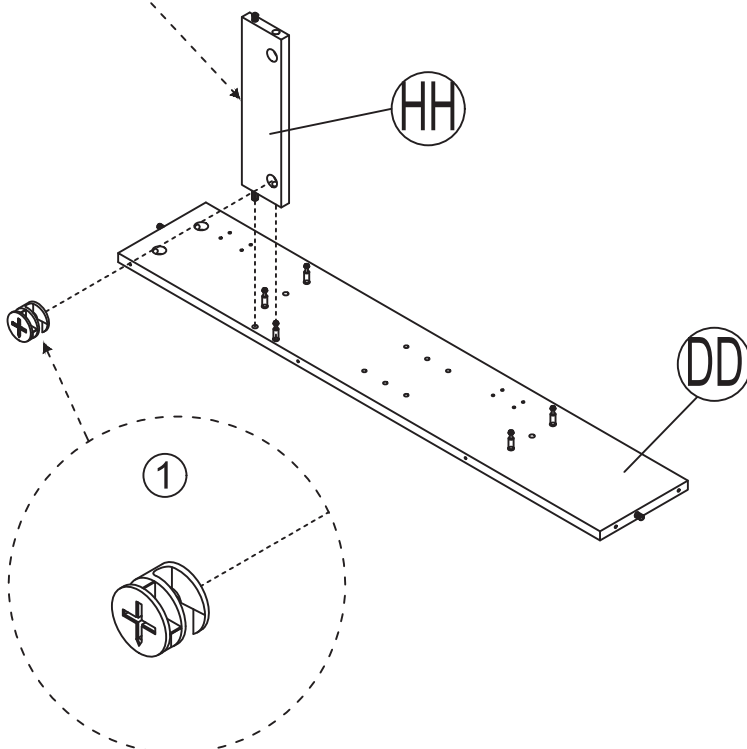

Insert the cam bolt into the hole first, then insert the cam lock and lock it.

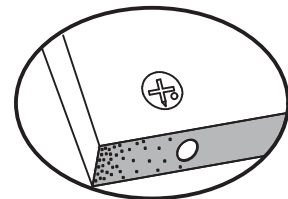

Proper orientation of CAM LOCK

STEP20

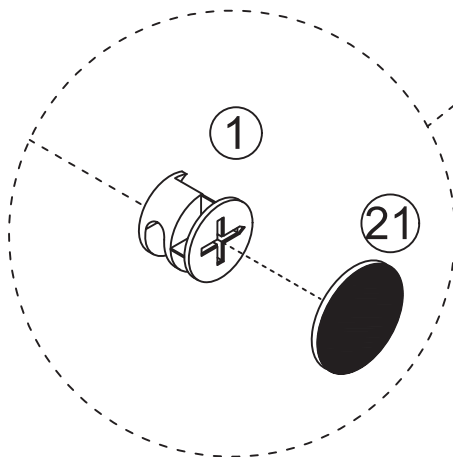
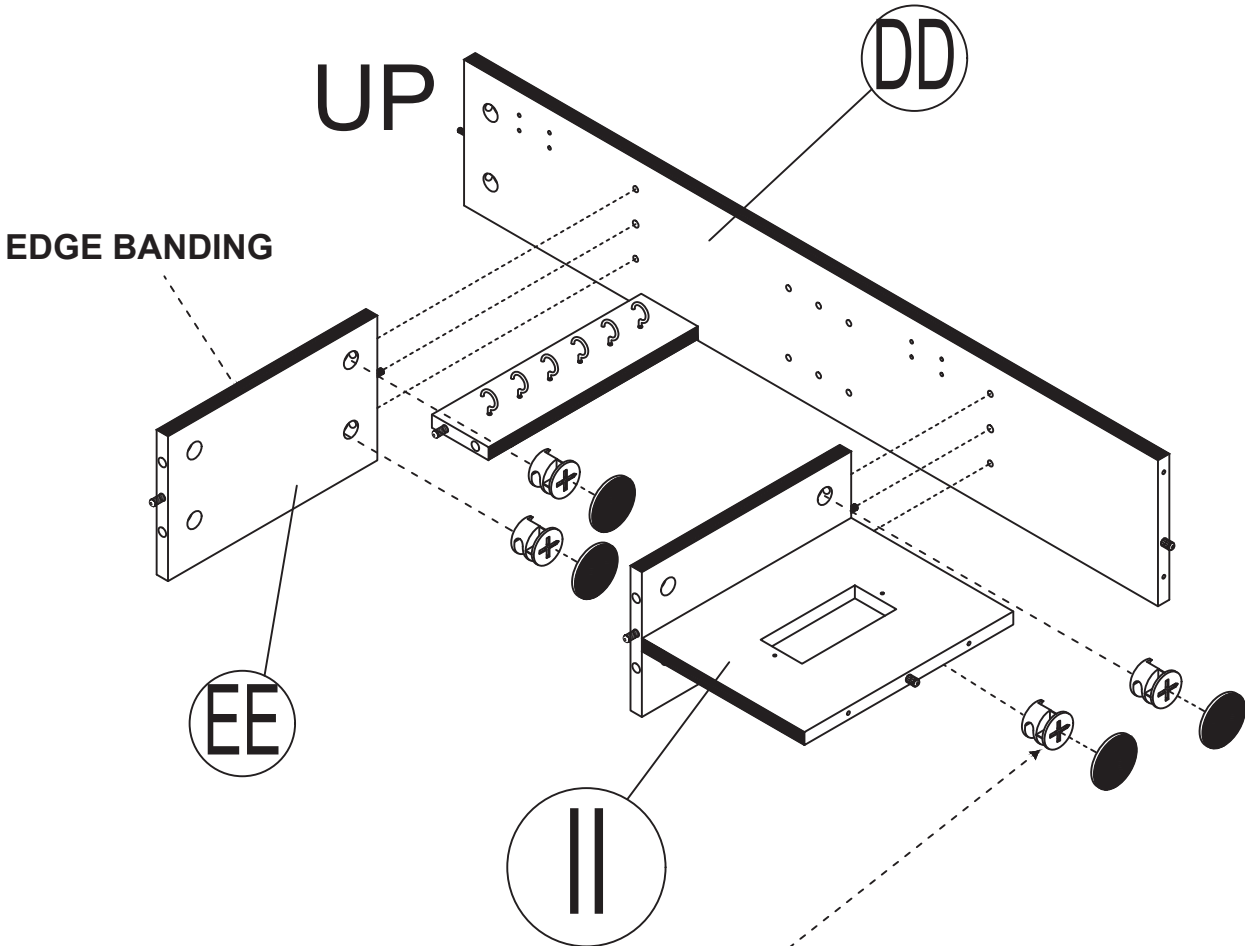
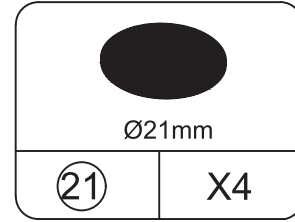
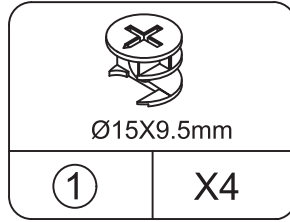
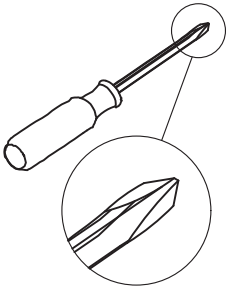

Lock first

Insert the cam bolt into the hole first, then insert the cam lock and lock it.

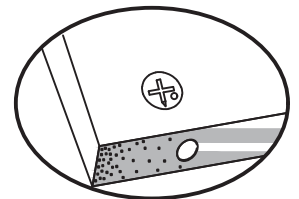

Proper orientation of CAM LOCK

STEP21

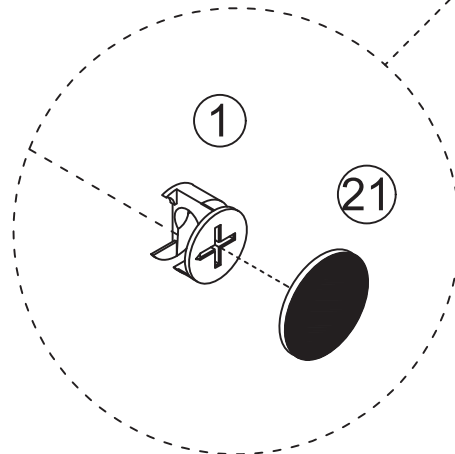
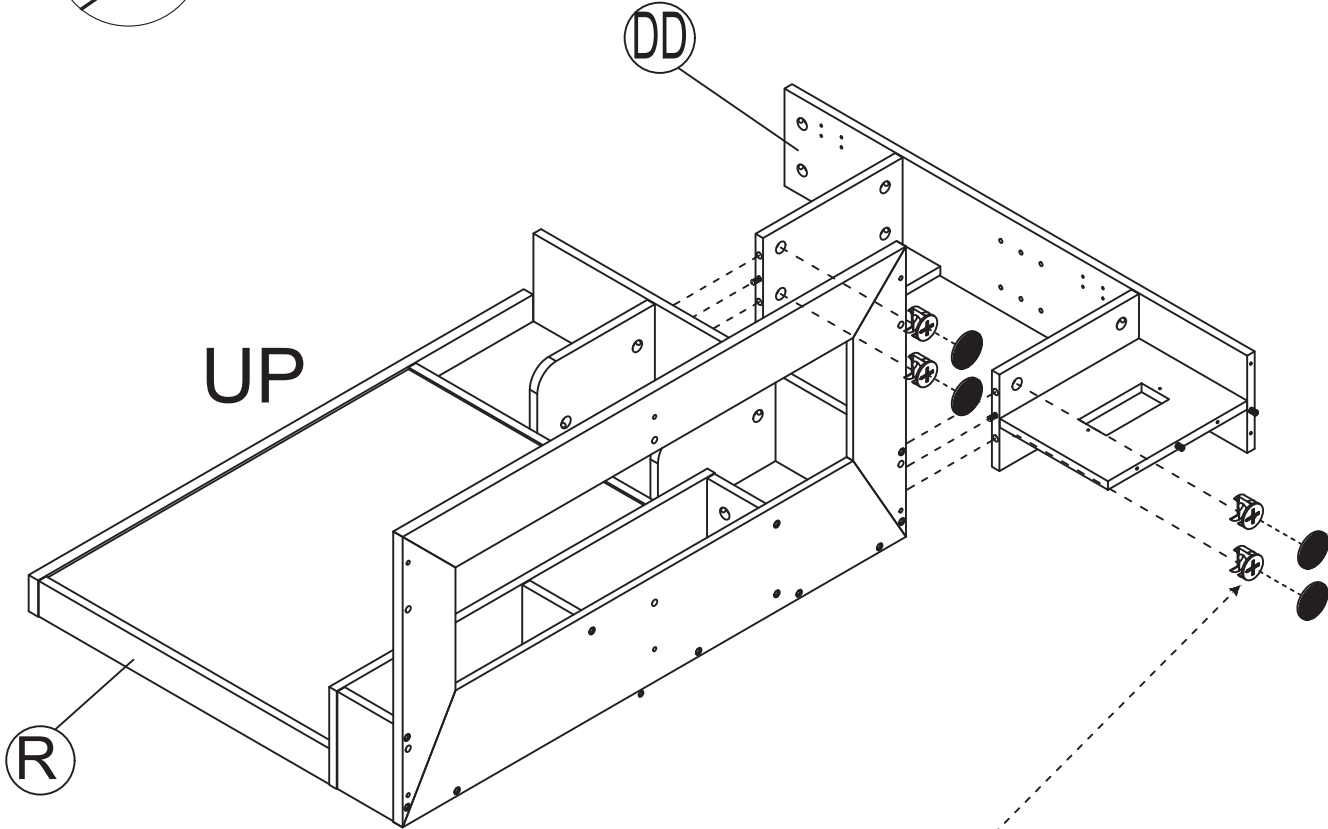
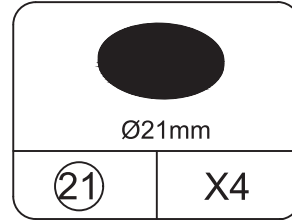
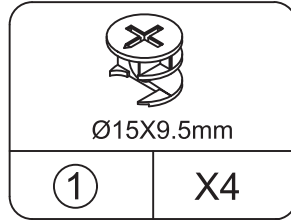
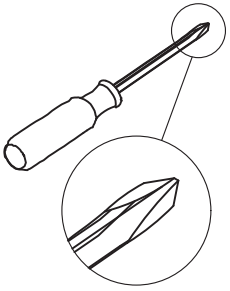

Insert the cam bolt into the hole first, then insert the cam lock and lock it.

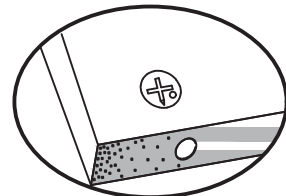

Proper orientation of CAM LOCK

STEP22

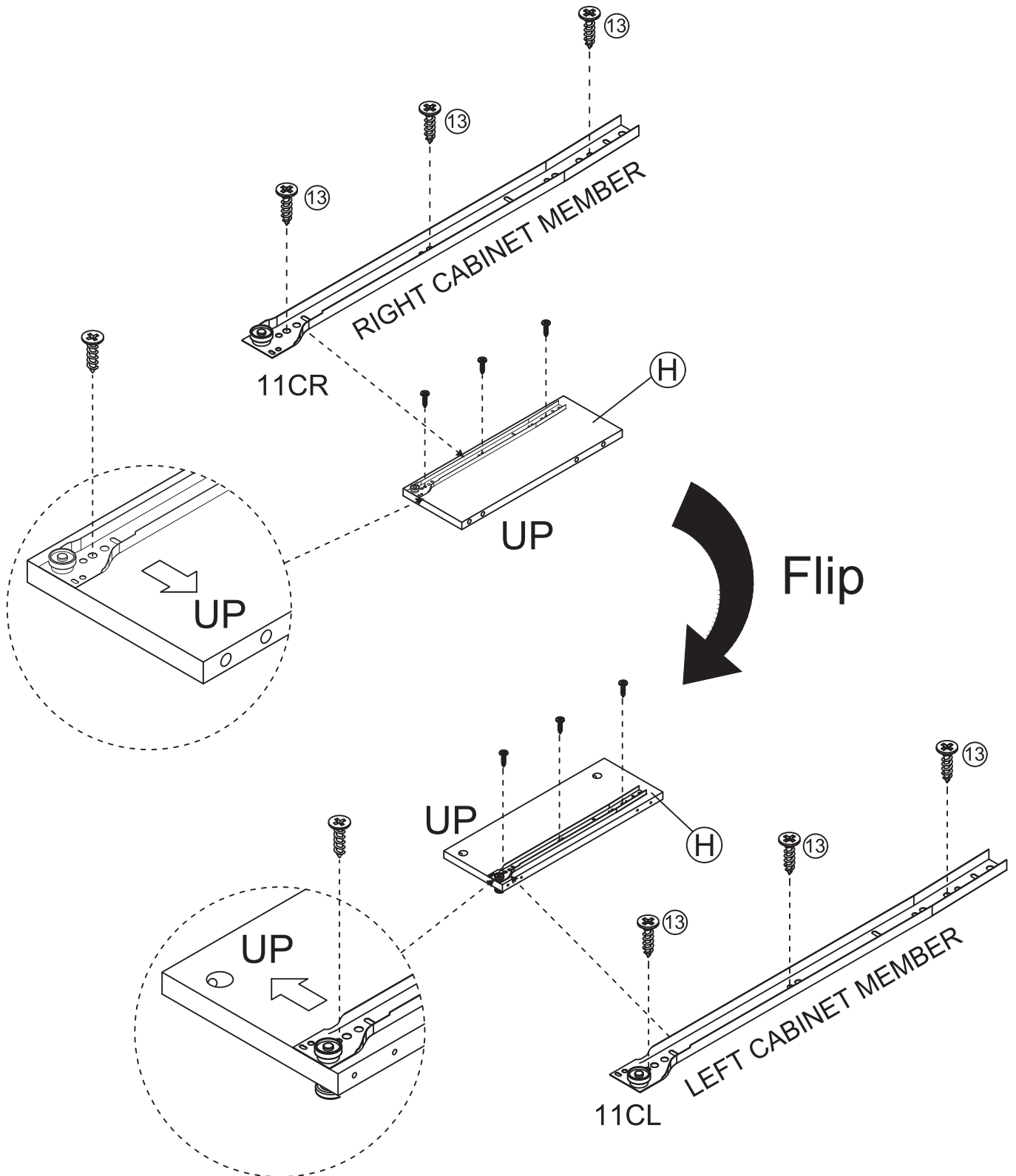
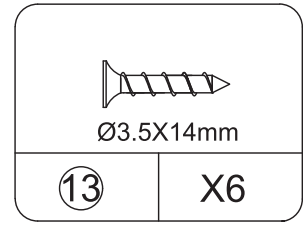
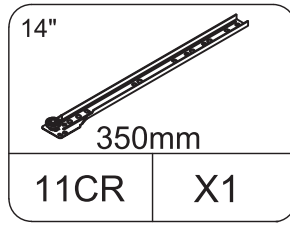
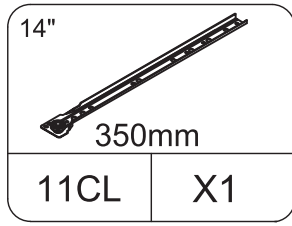
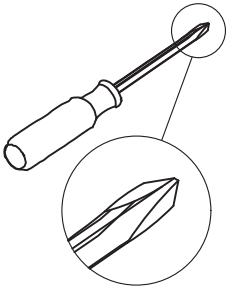

STEP23

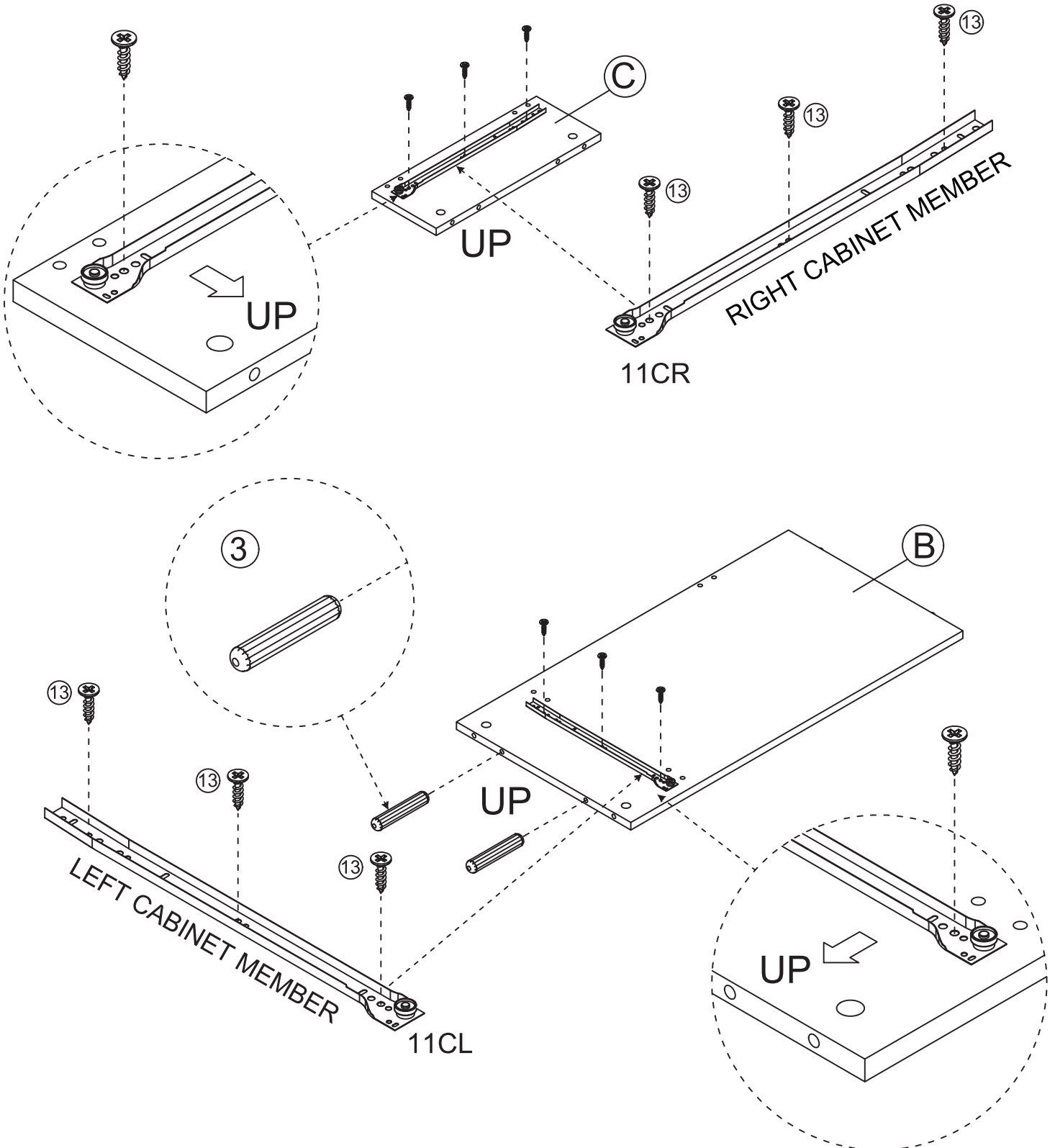
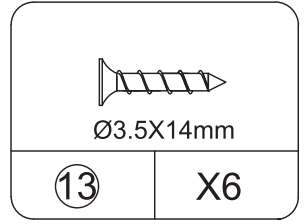
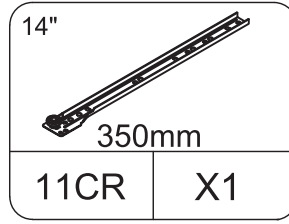
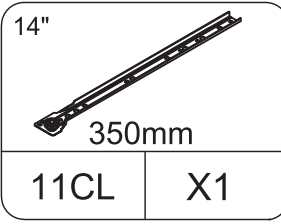
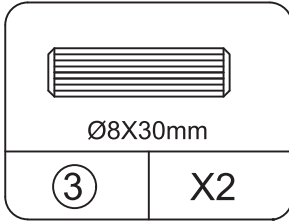
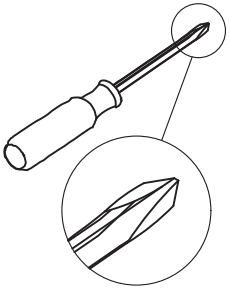

STEP24

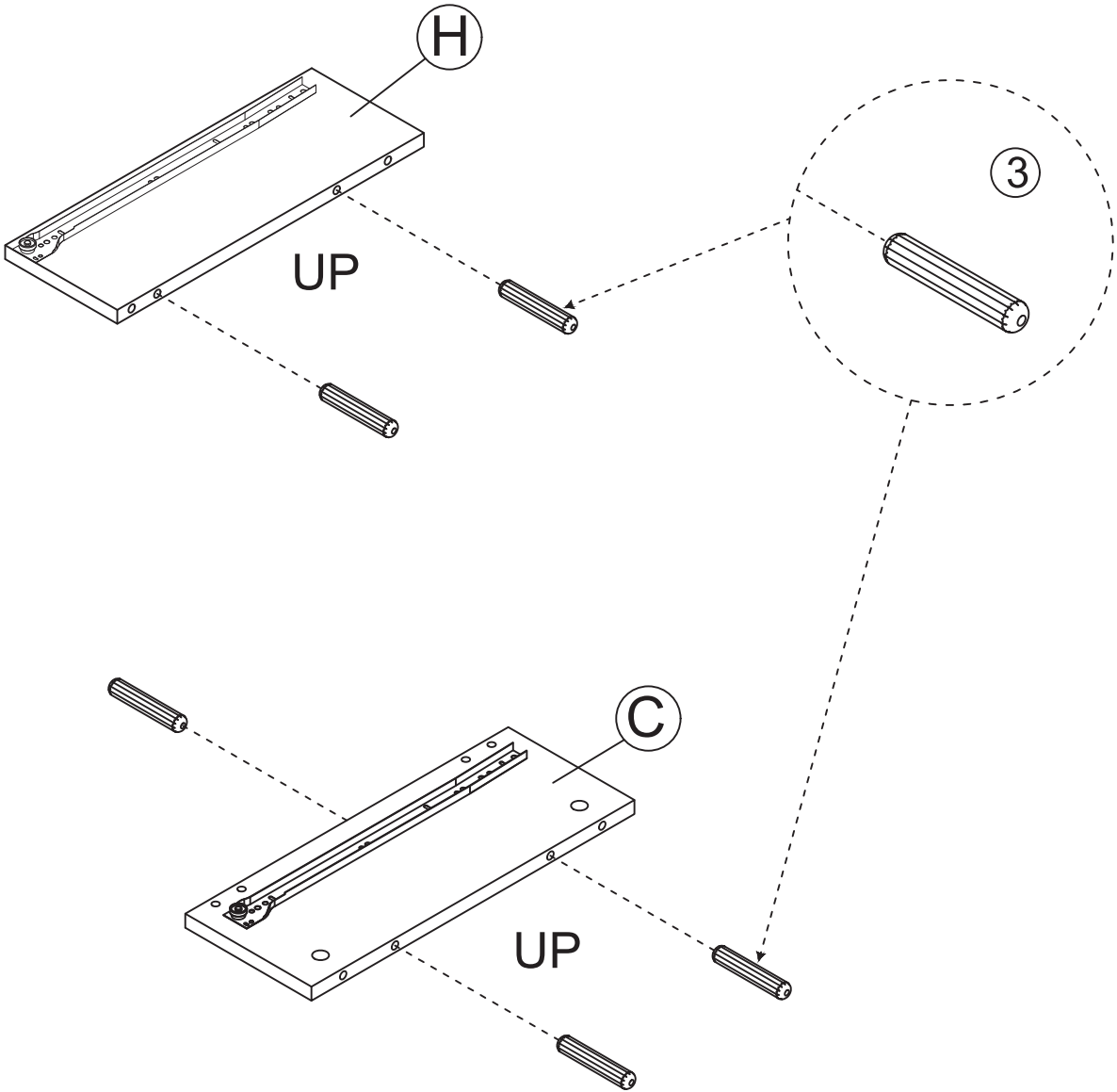
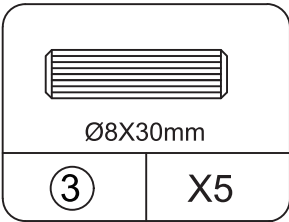

STEP25

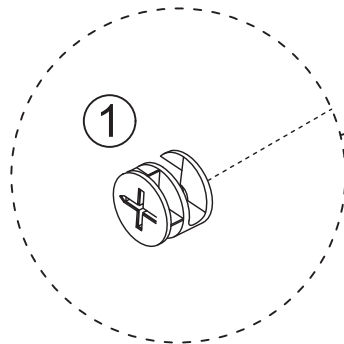
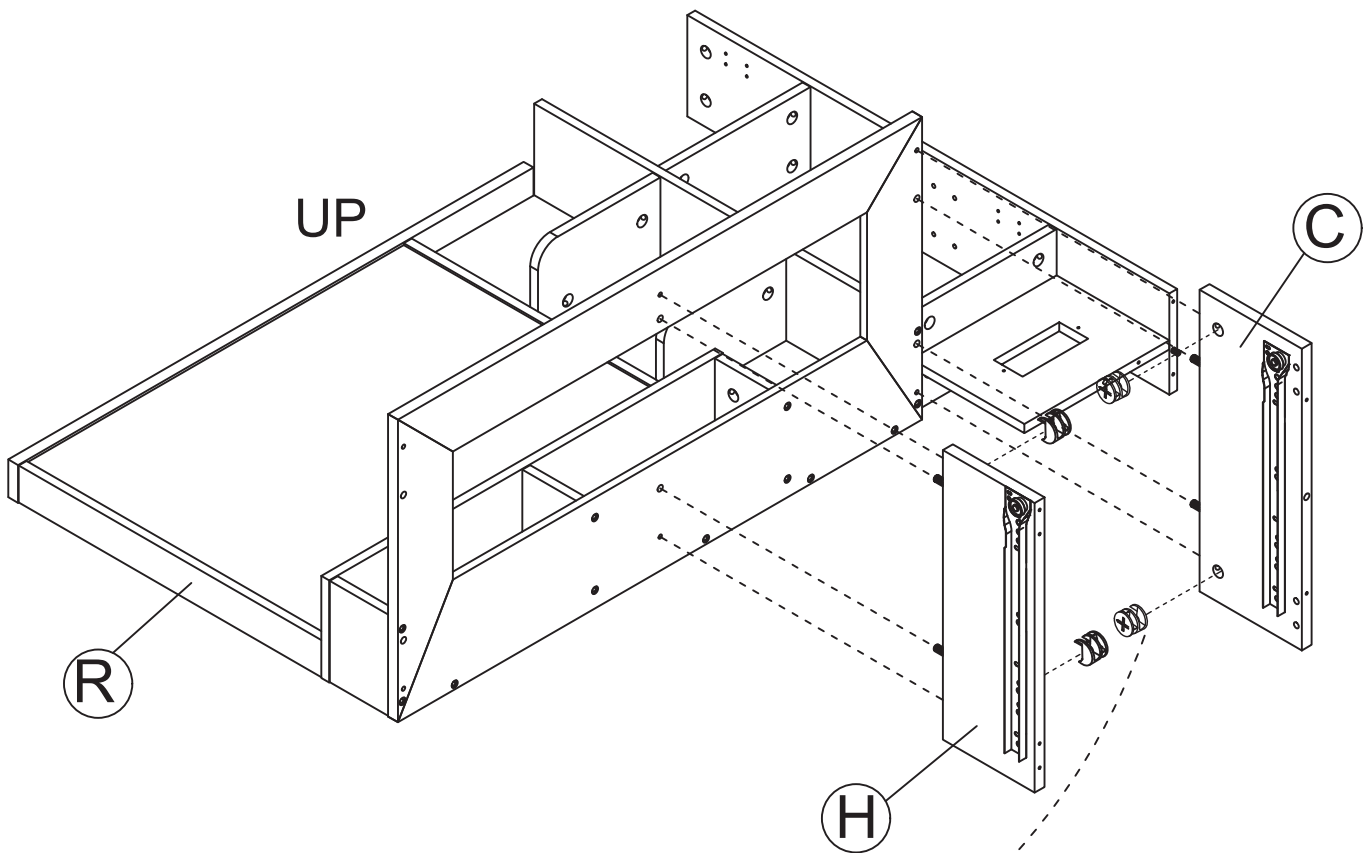
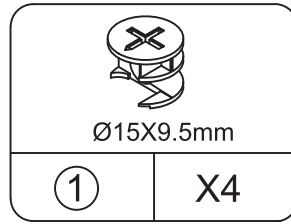
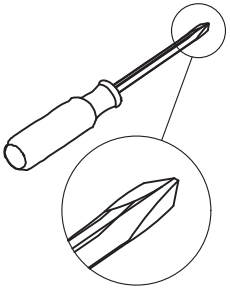

Insert the cam bolt into the hole first, then insert the cam lock and lock it.

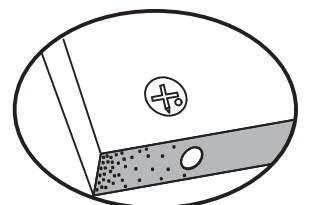

Proper orientation of CAM LOCK

STEP26

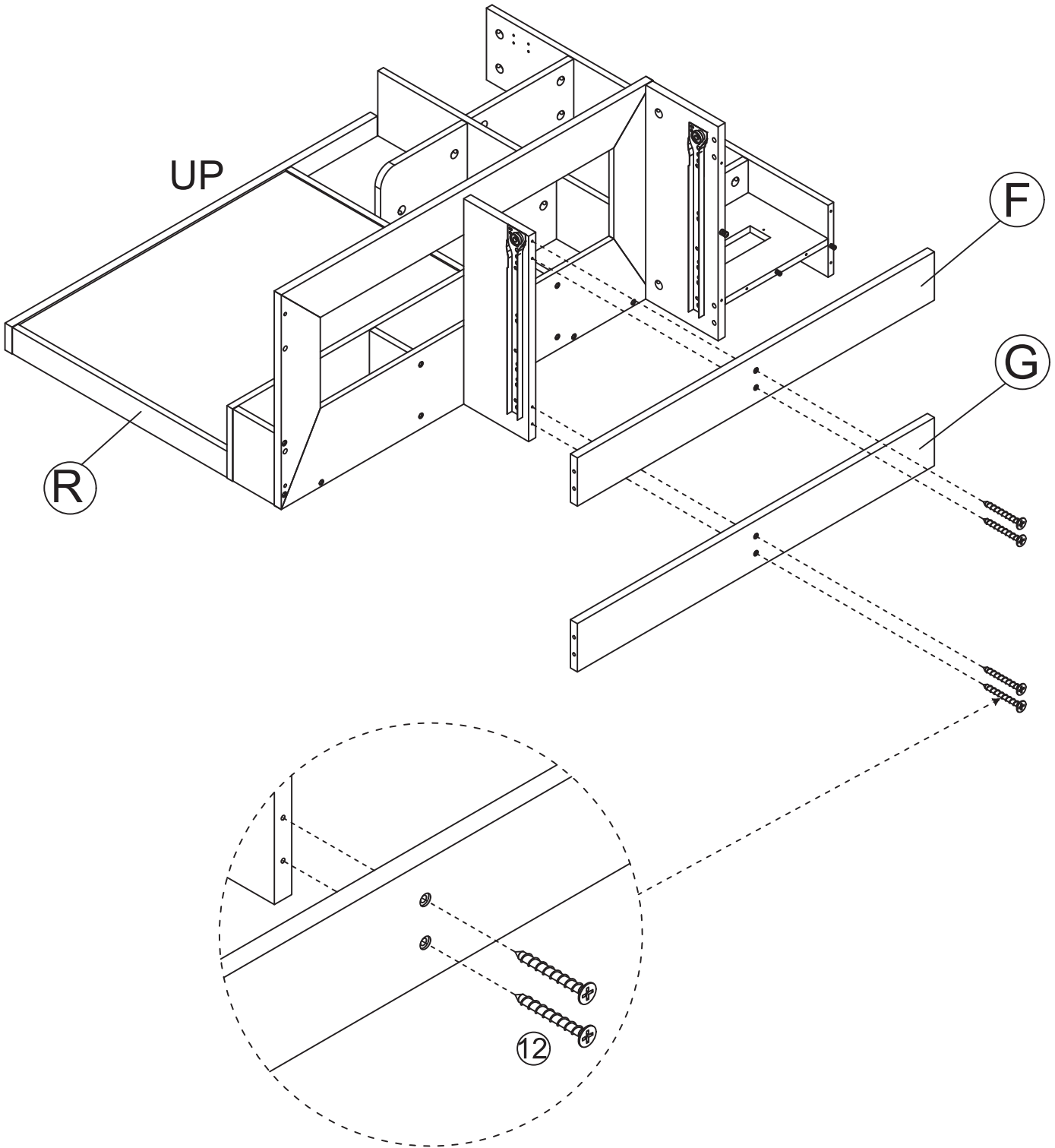
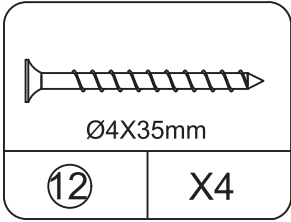
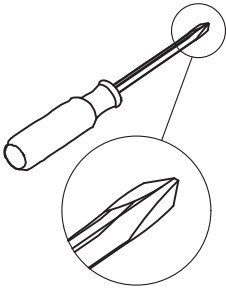

STEP27

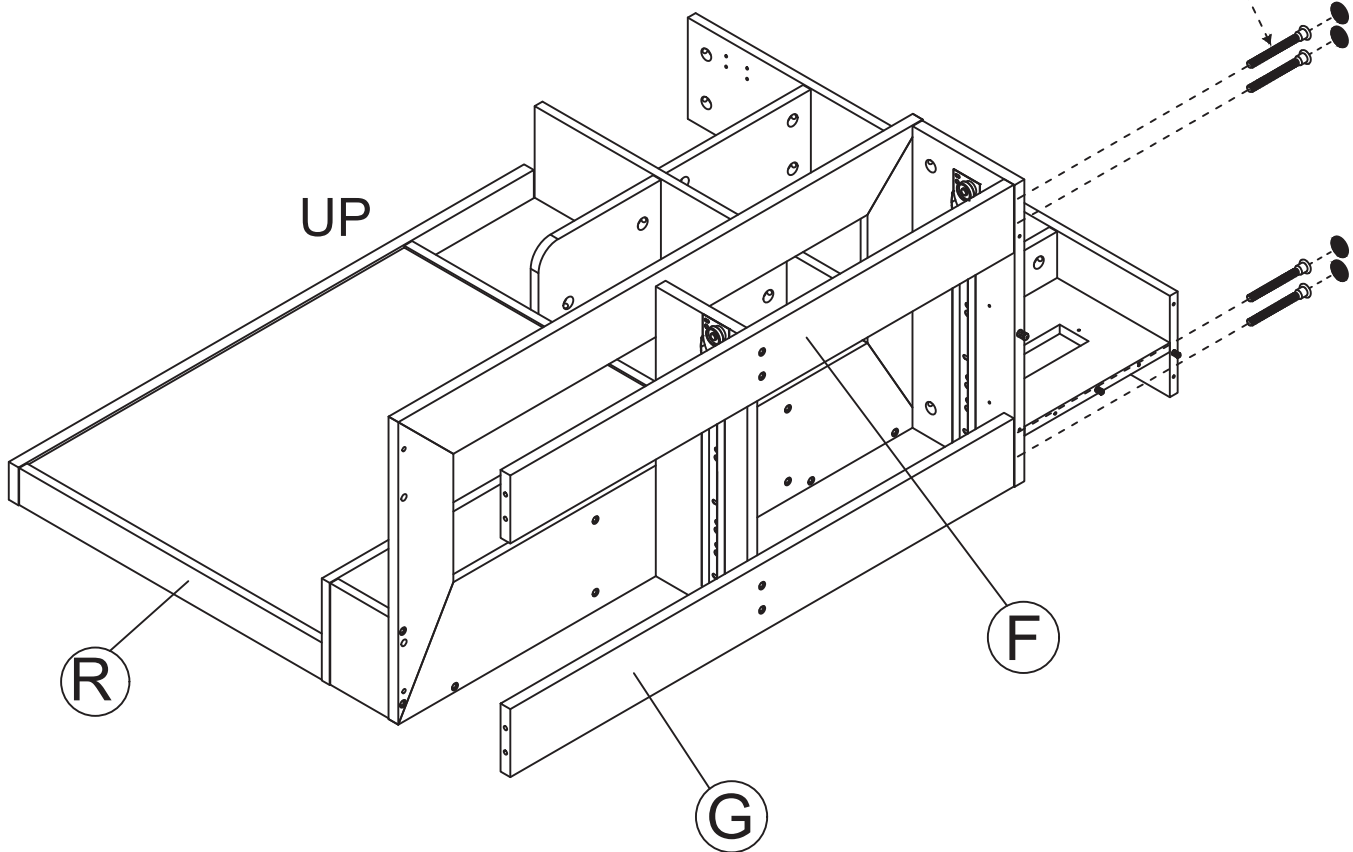
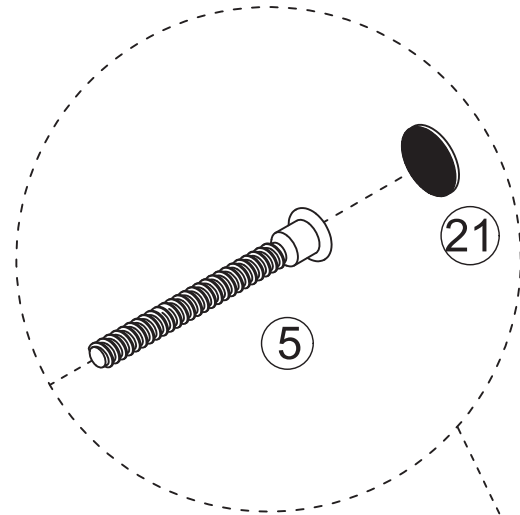
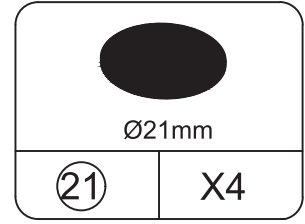
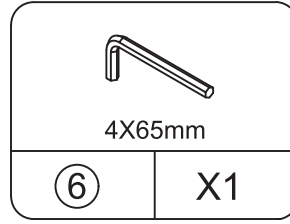
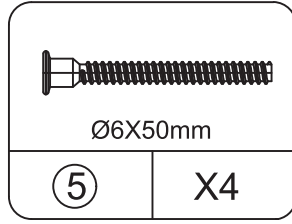
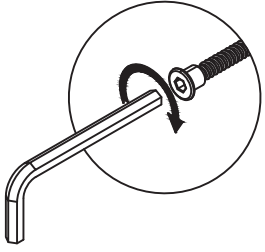

STEP28

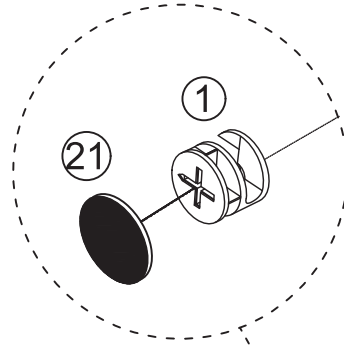
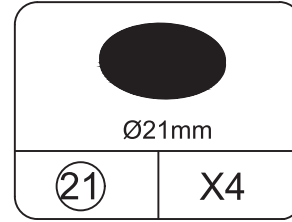
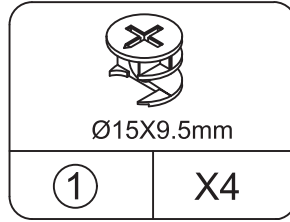
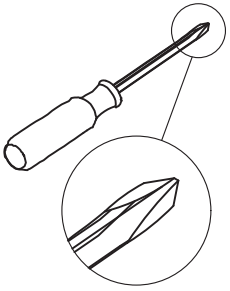

Lock first

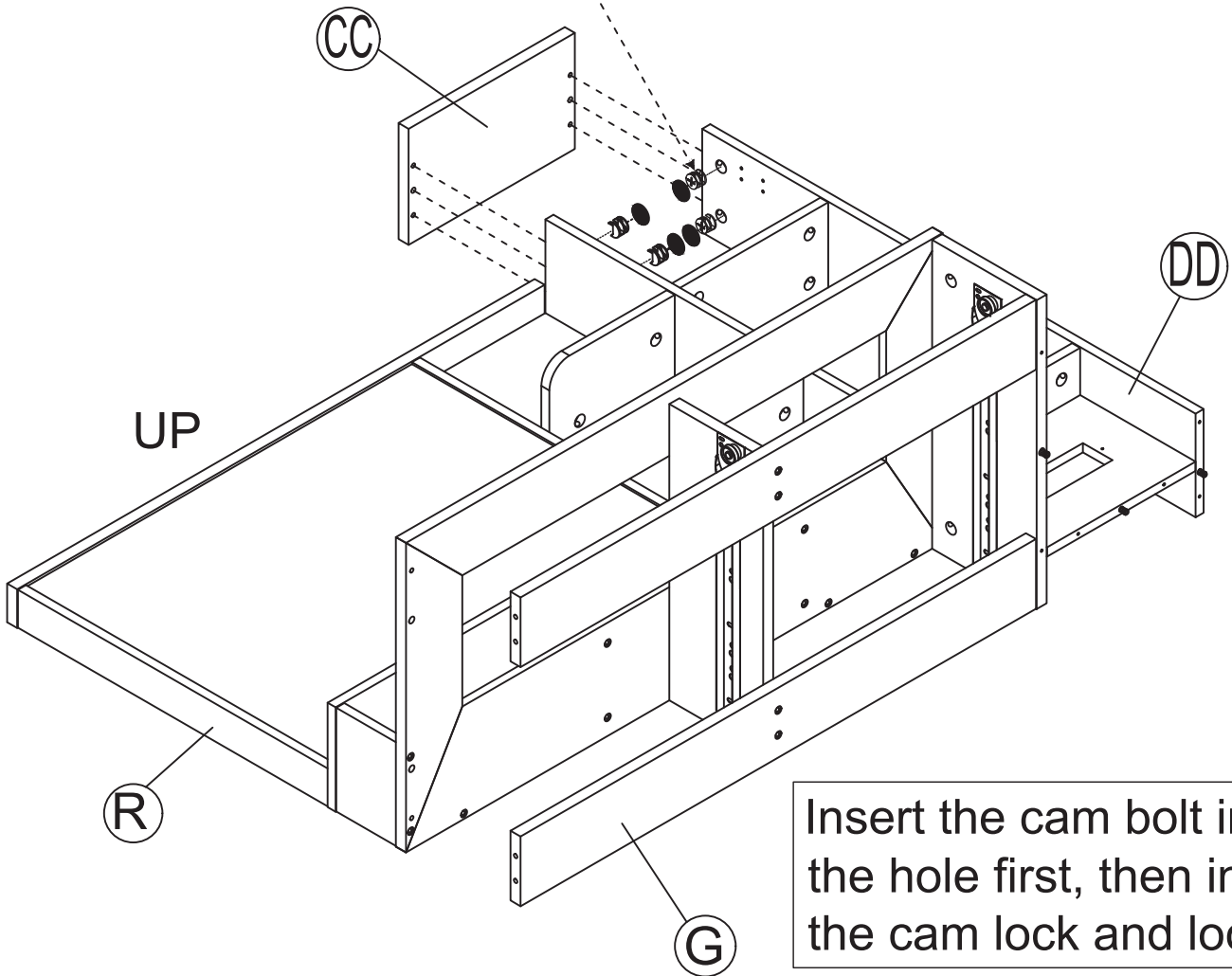

Insert the cam bolt into the hole first, then insert the cam lock and lock it.

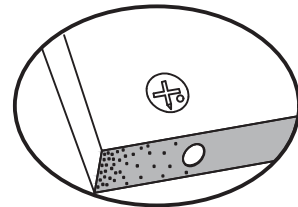

Proper orientation of CAM LOCK

STEP 29

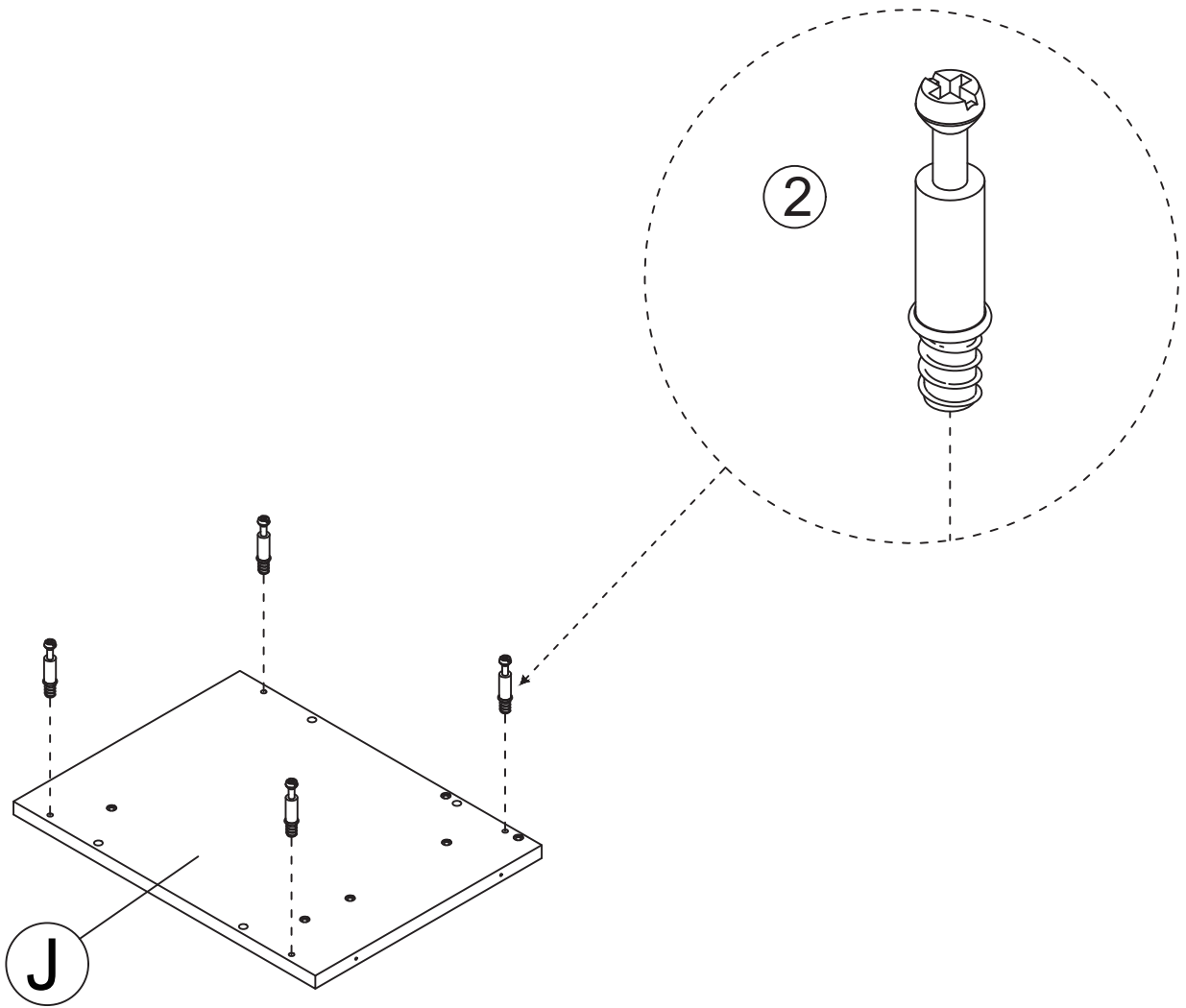
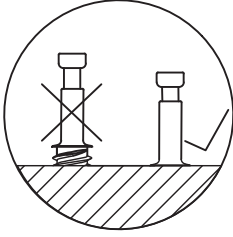
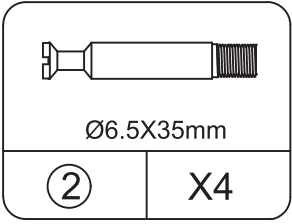
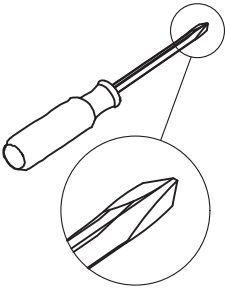

STEP30

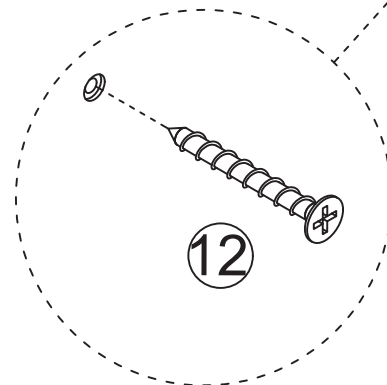
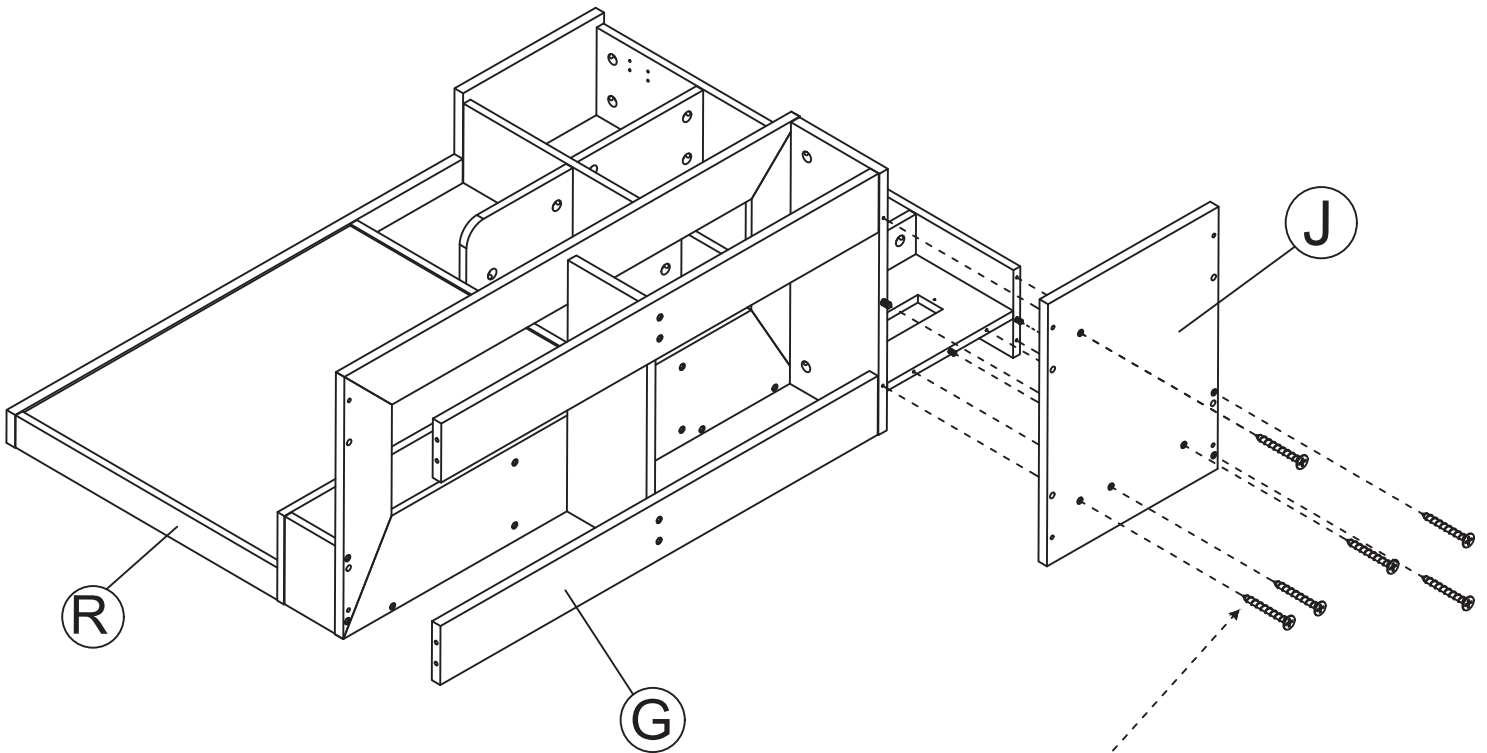
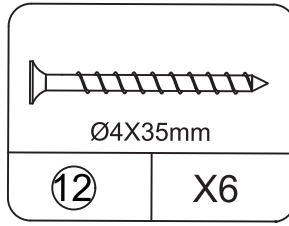
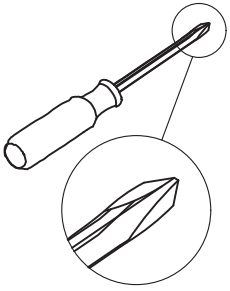

STEP31

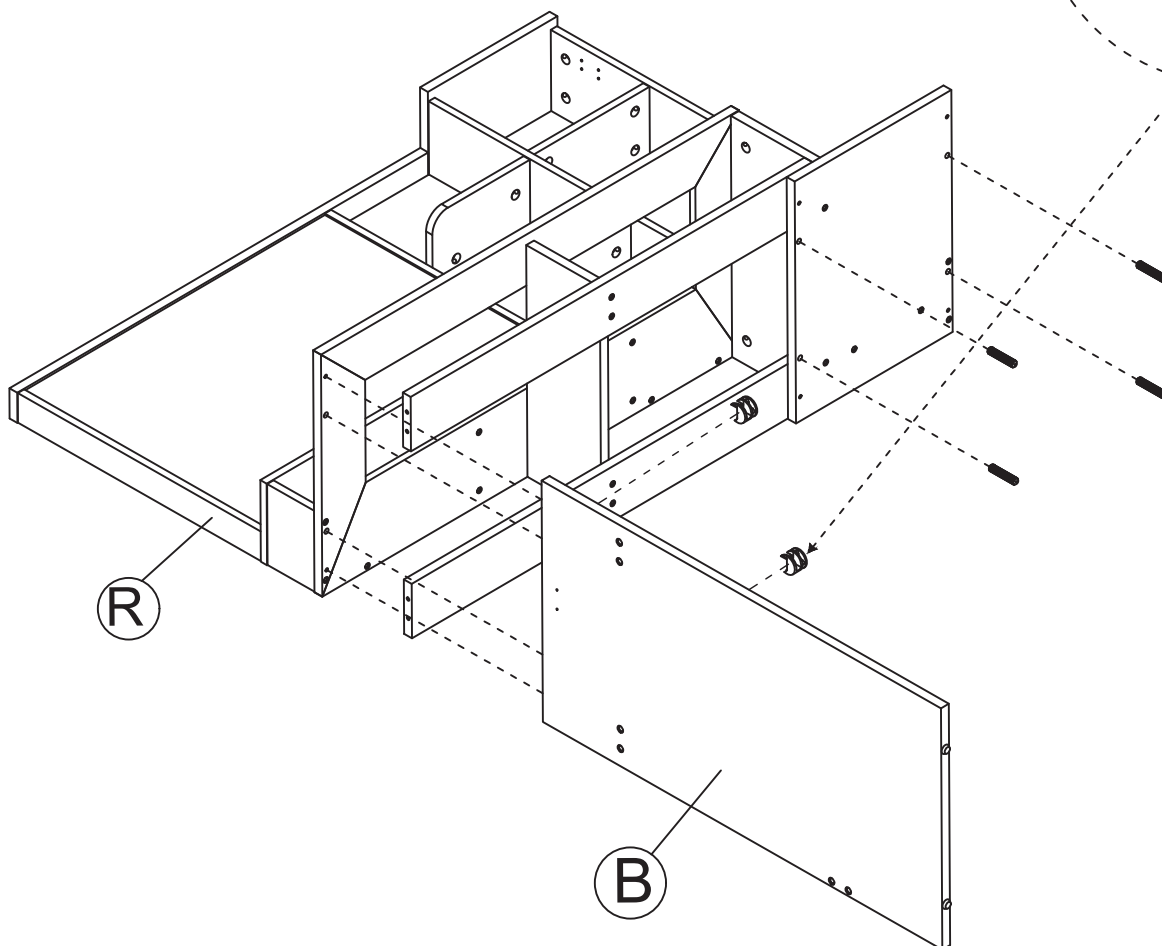
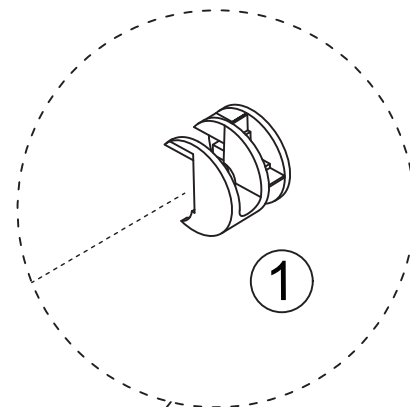
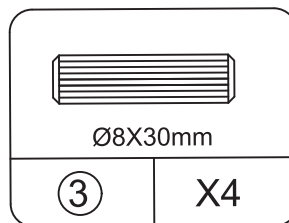
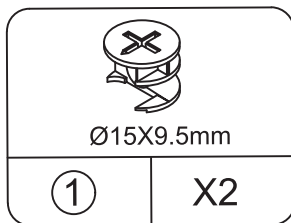
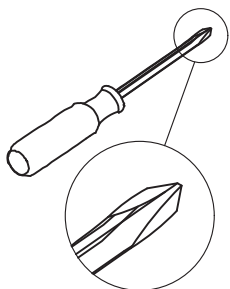

Insert the cam bolt into the hole first, then insert the cam lock and lock it.

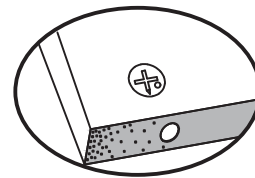

Proper orientation of CAM LOCK

STEP32

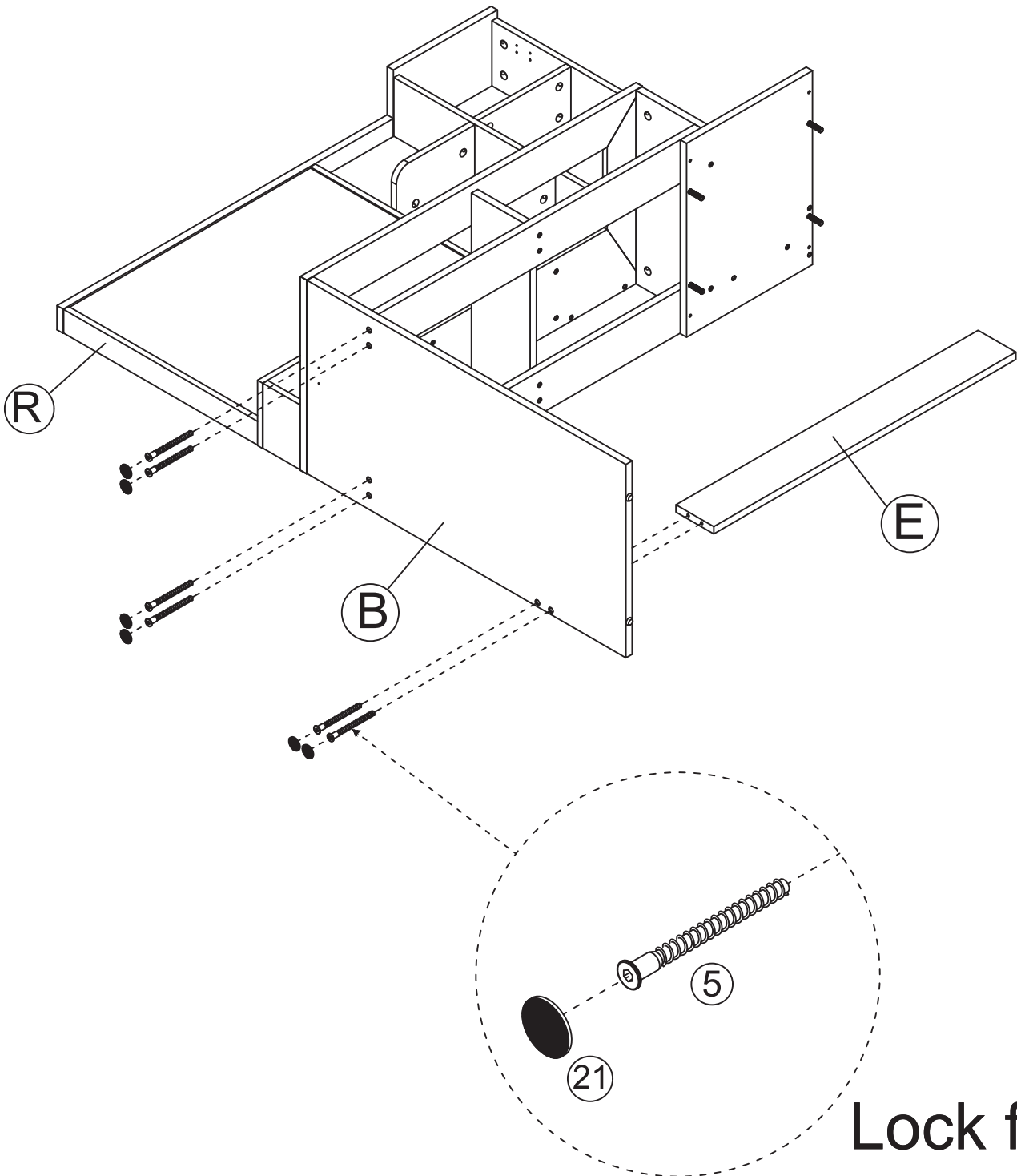
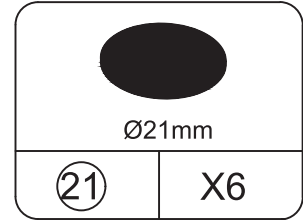
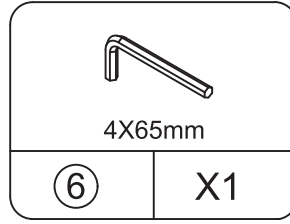
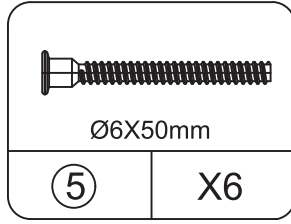
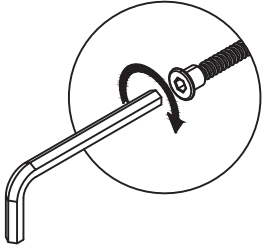

STEP33

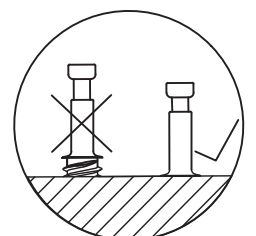
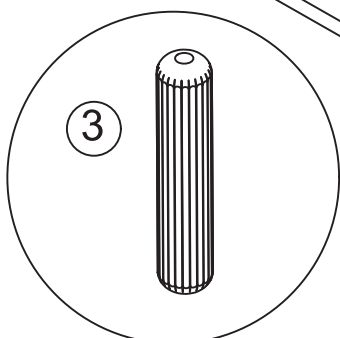
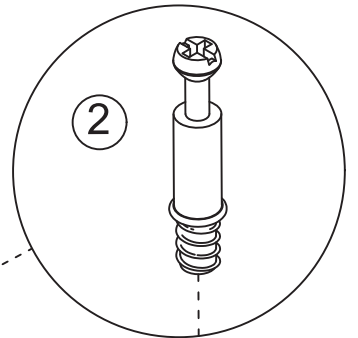
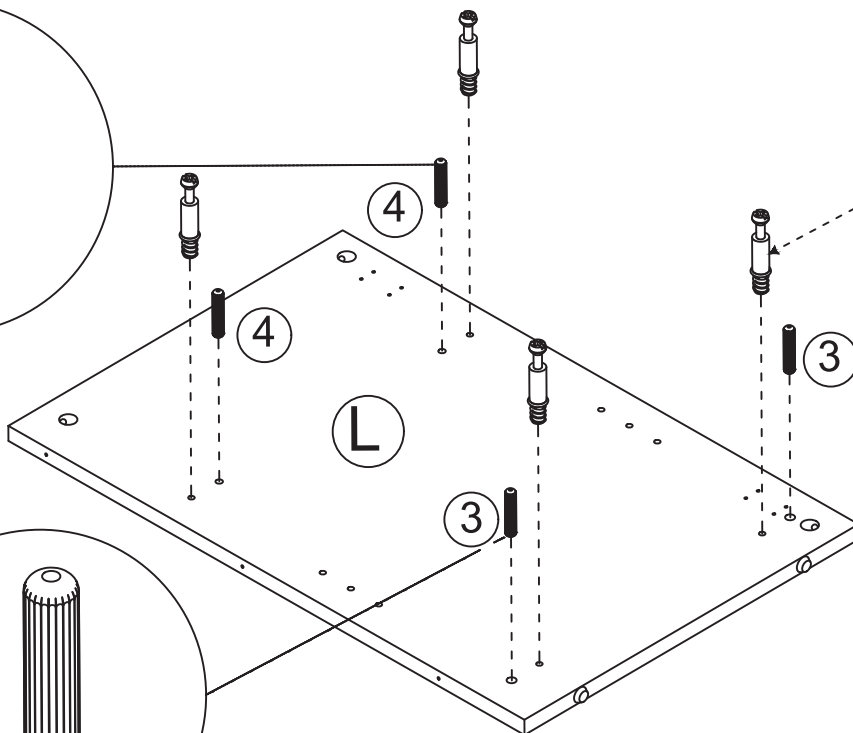
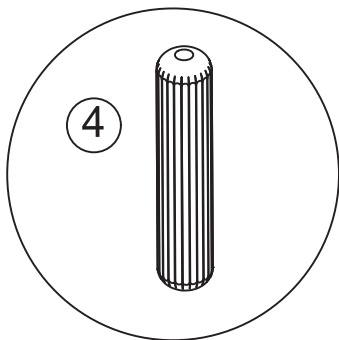
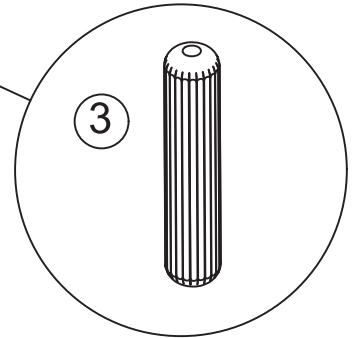
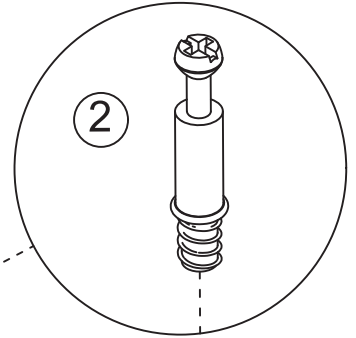
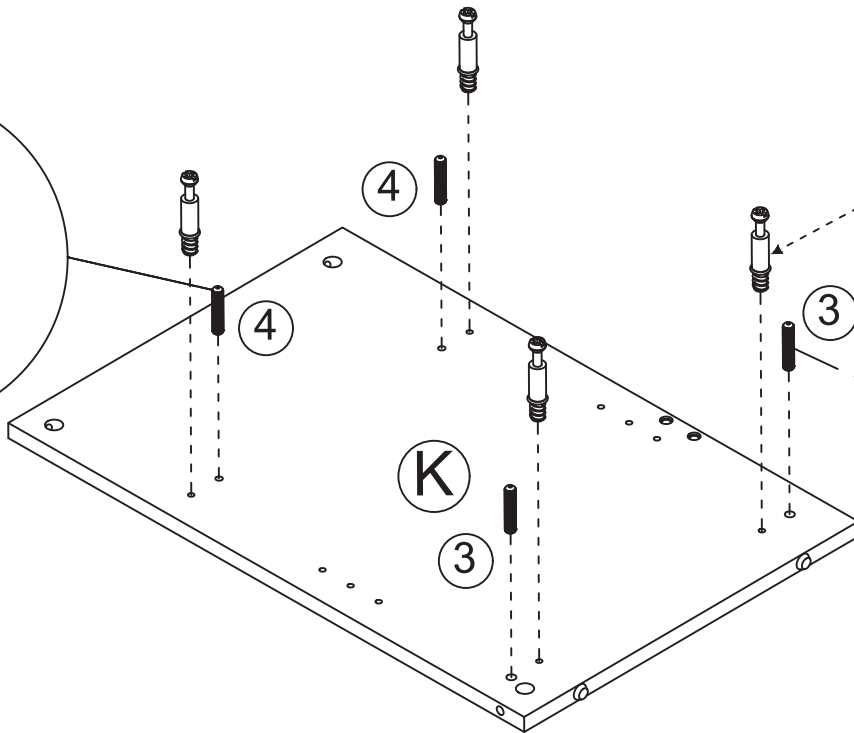
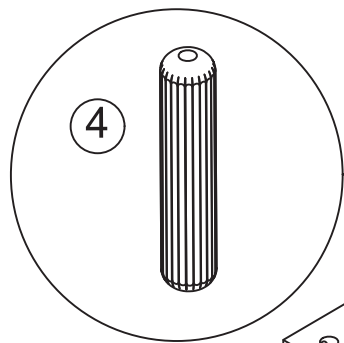
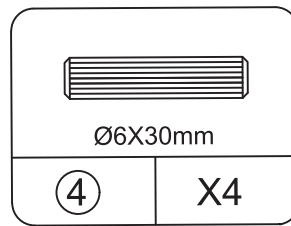
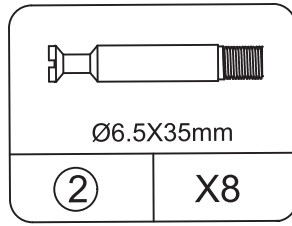
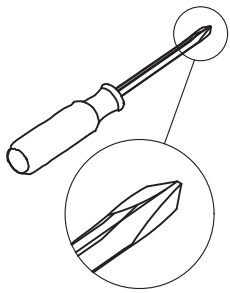

STEP34

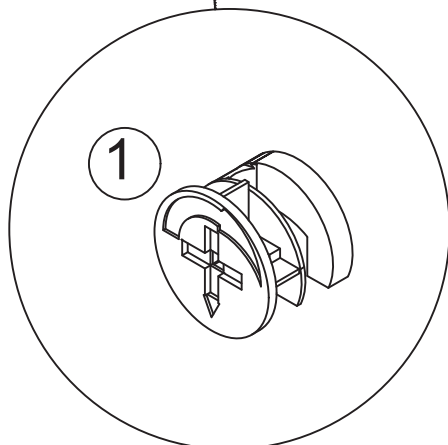
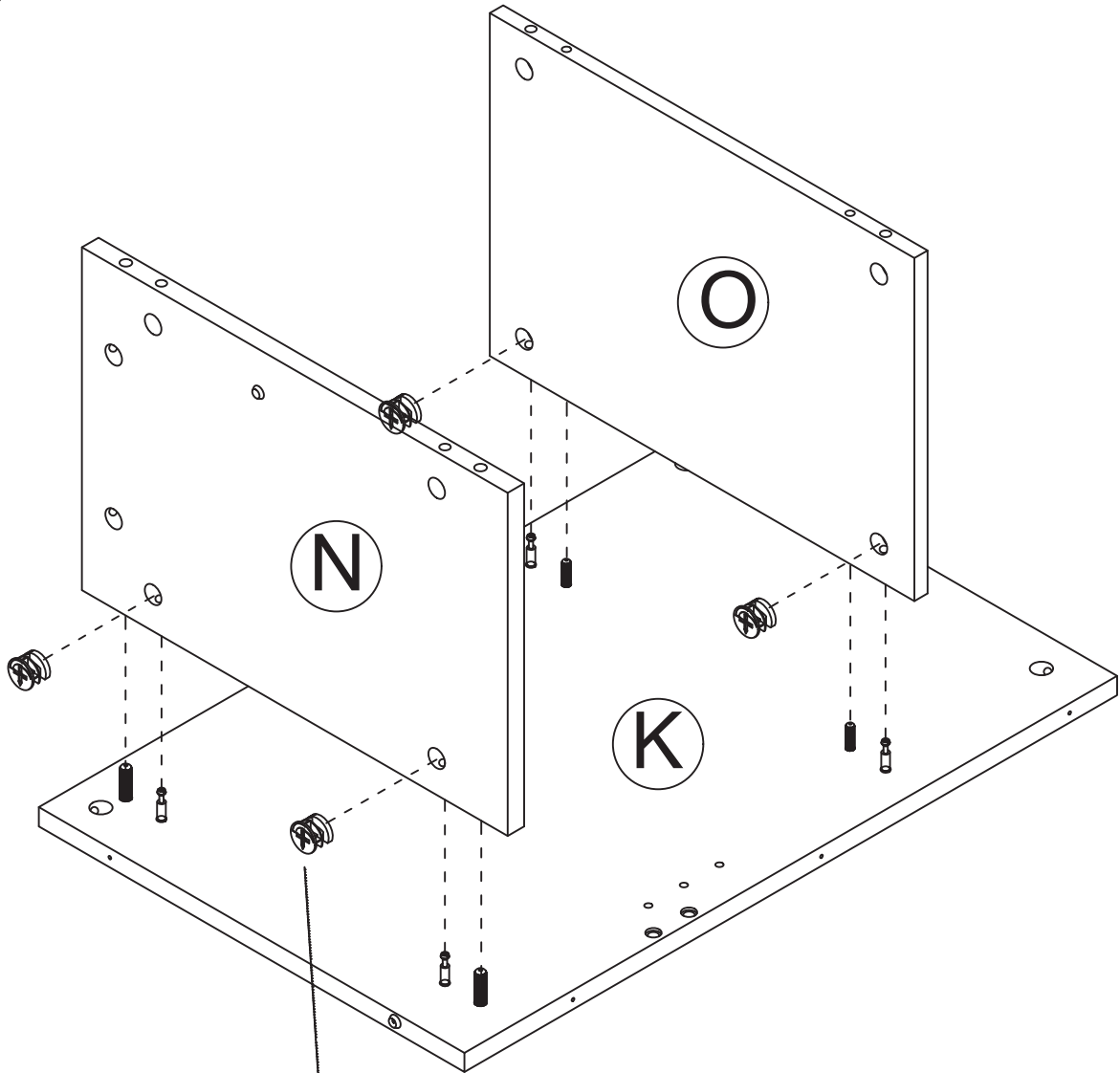
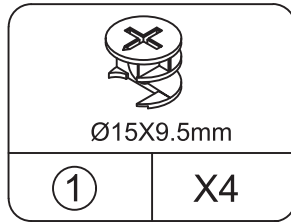
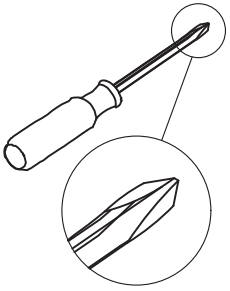

Insert the cam bolt into the hole first, then insert the cam lock and lock it.

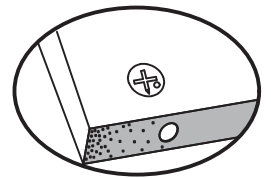

Proper orientation of CAM LOCK

STEP35

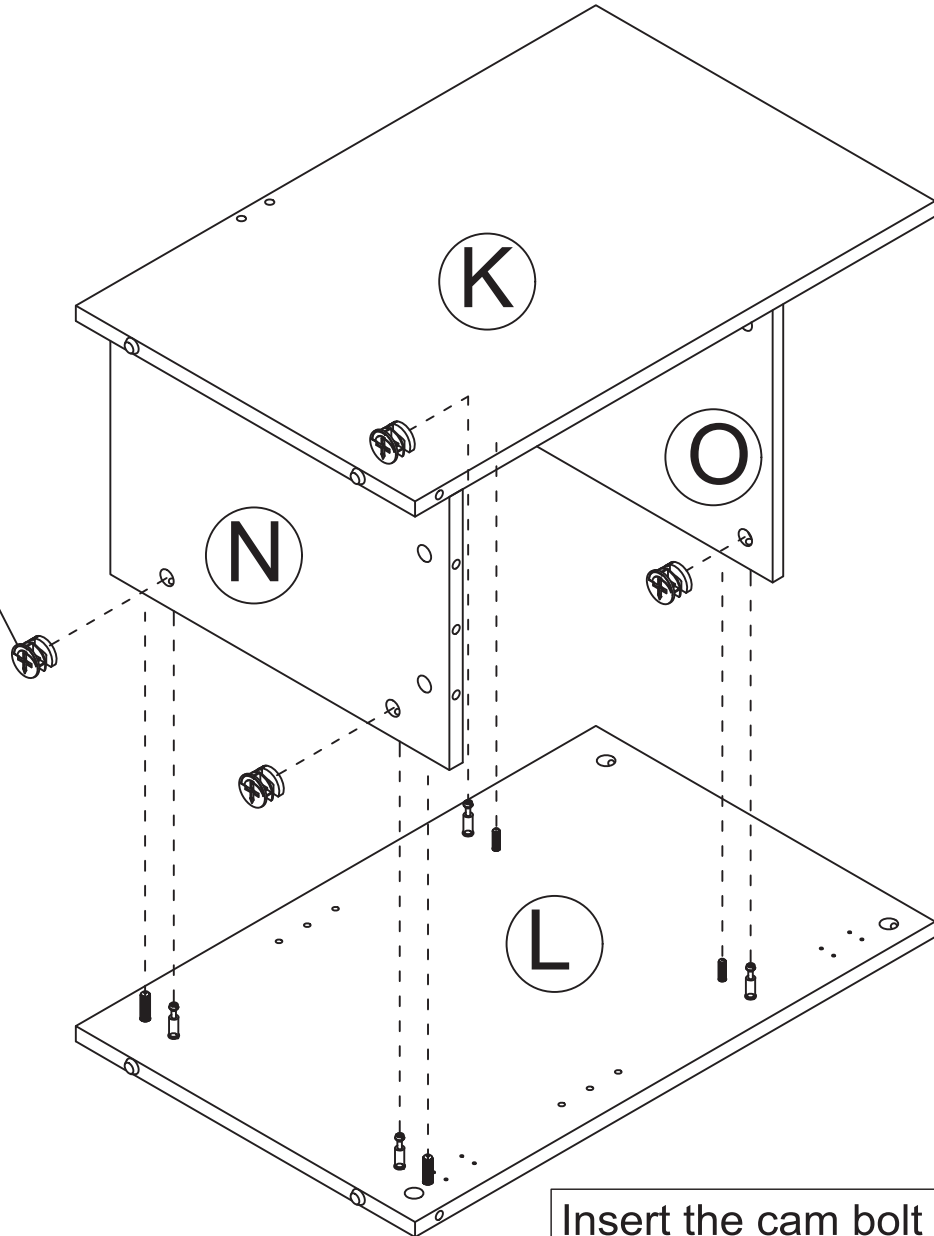
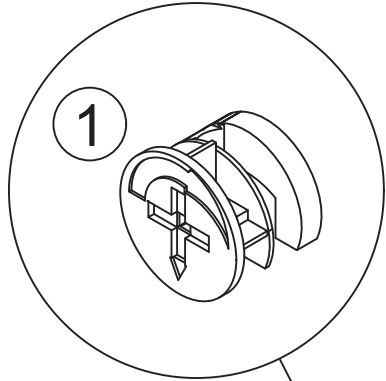
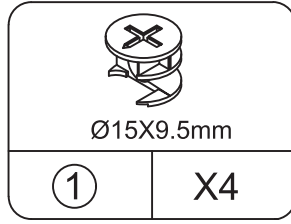
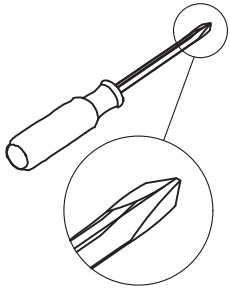

Insert the cam bolt into the hole first, then insert the cam lock and lock it.

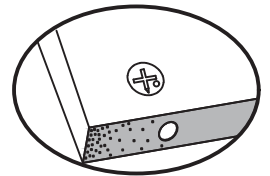

Proper orientation of CAM LOCK

STEP36

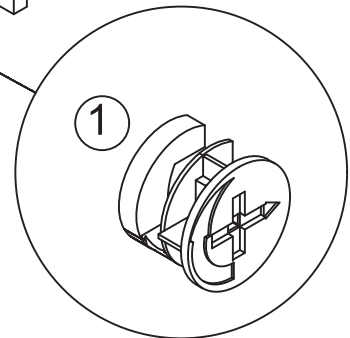
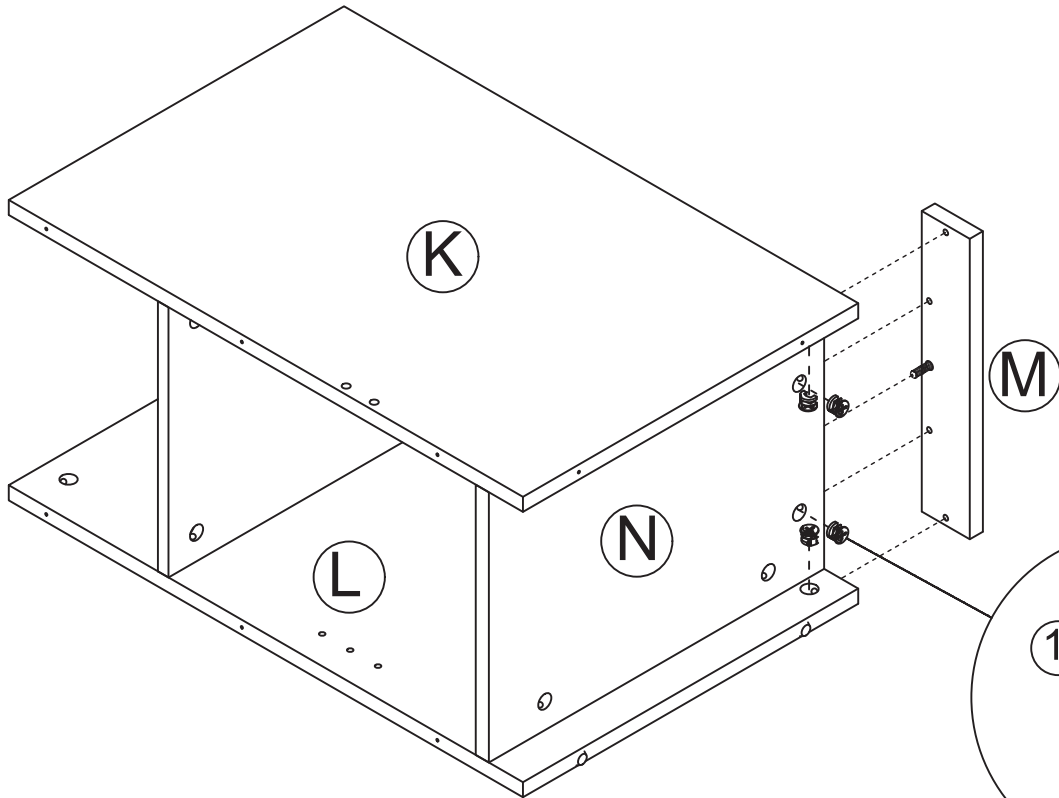
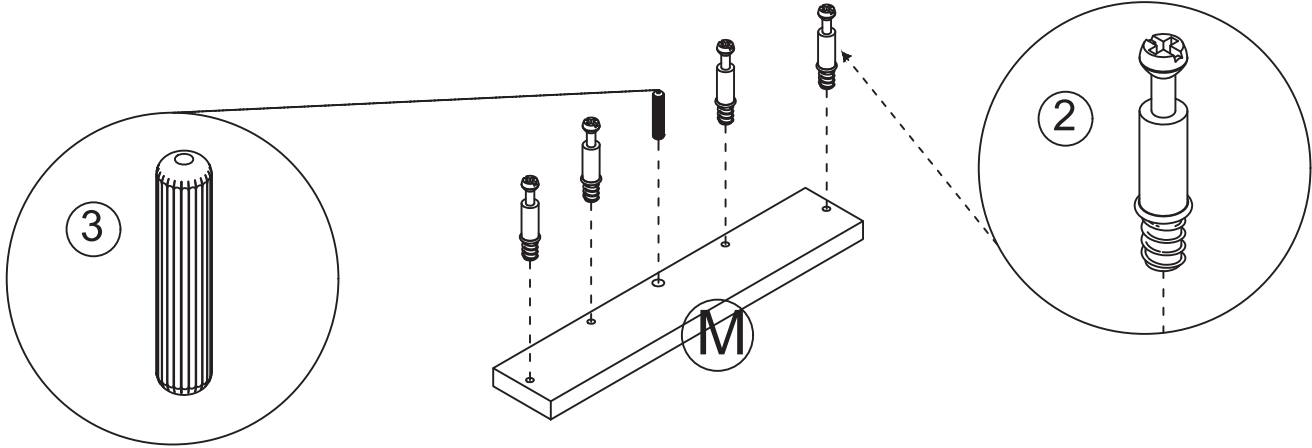
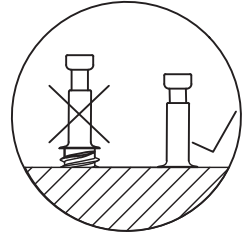
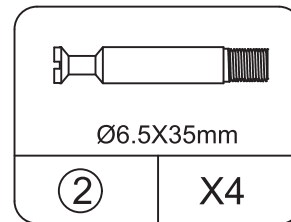
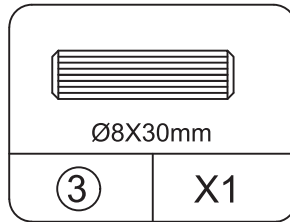
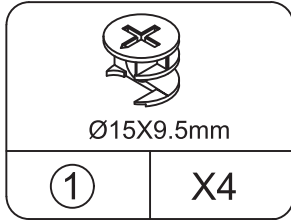
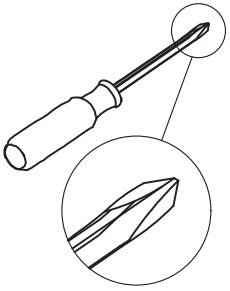

Insert the cam bolt into the hole first, then insert the cam lock and lock it.

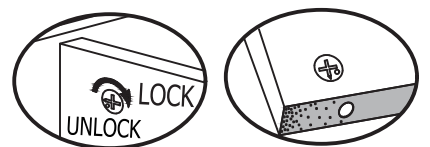

Proper orientation of CAM LOCK

STEP37

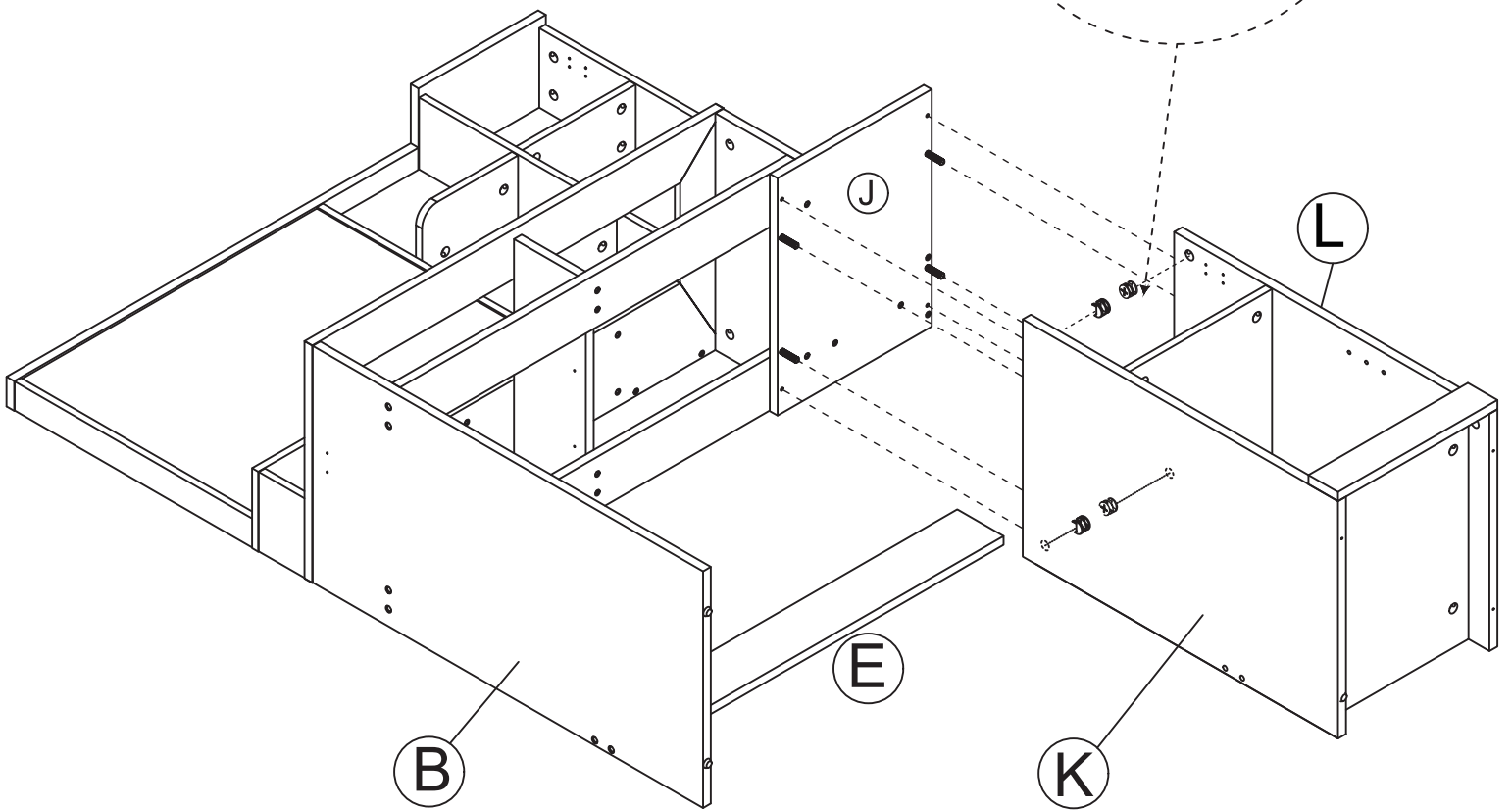
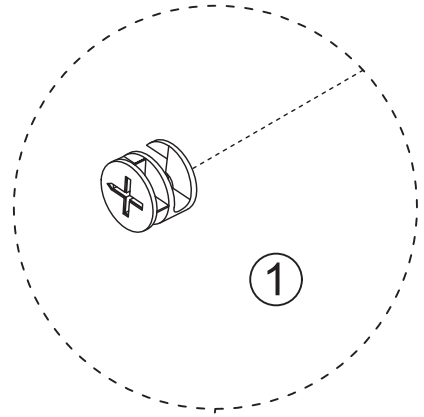
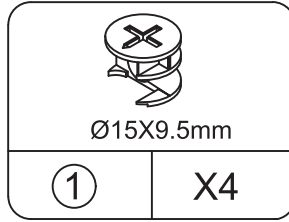
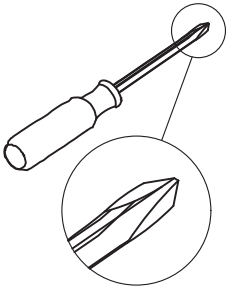

Insert the cam bolt into the hole first, then insert the cam lock and lock it.

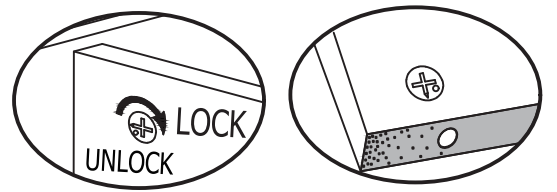

Proper orientation of CAM LOCK

STEP38

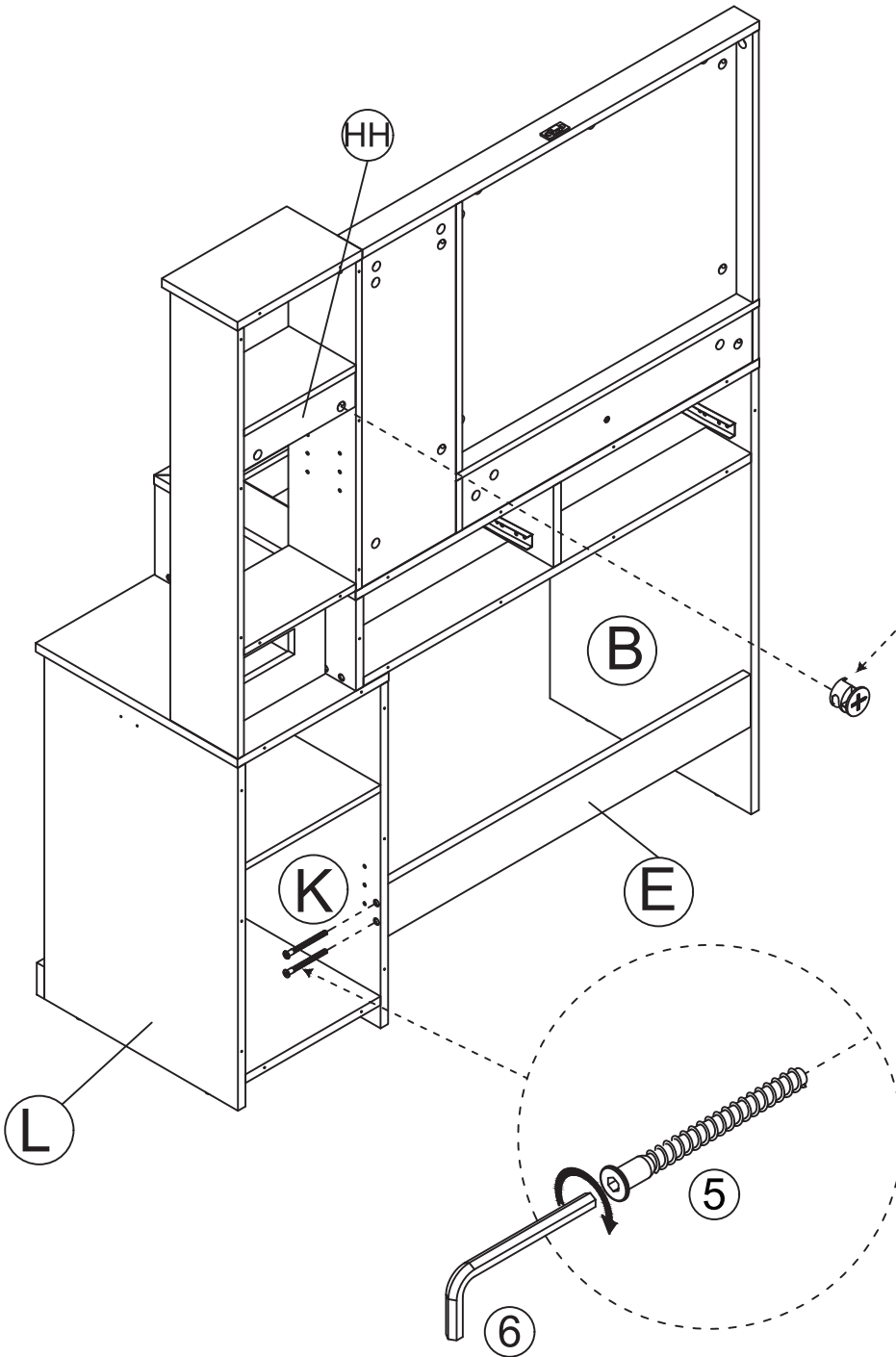
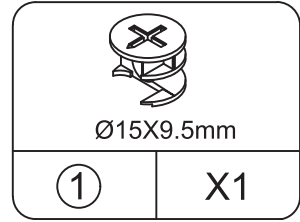
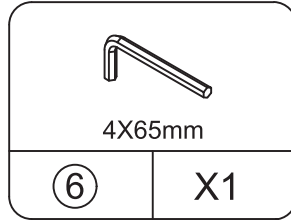
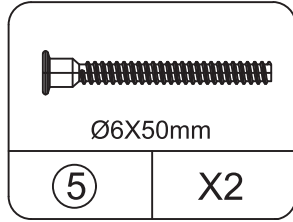
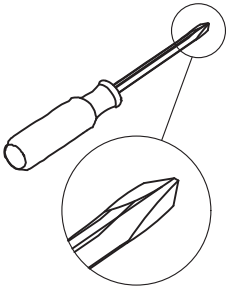

Insert the cam bolt into the hole first, then insert the cam lock and lock it.

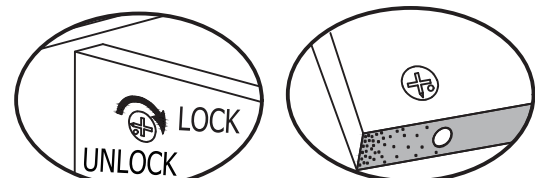

Proper orientation of CAM LOCK

STEP39

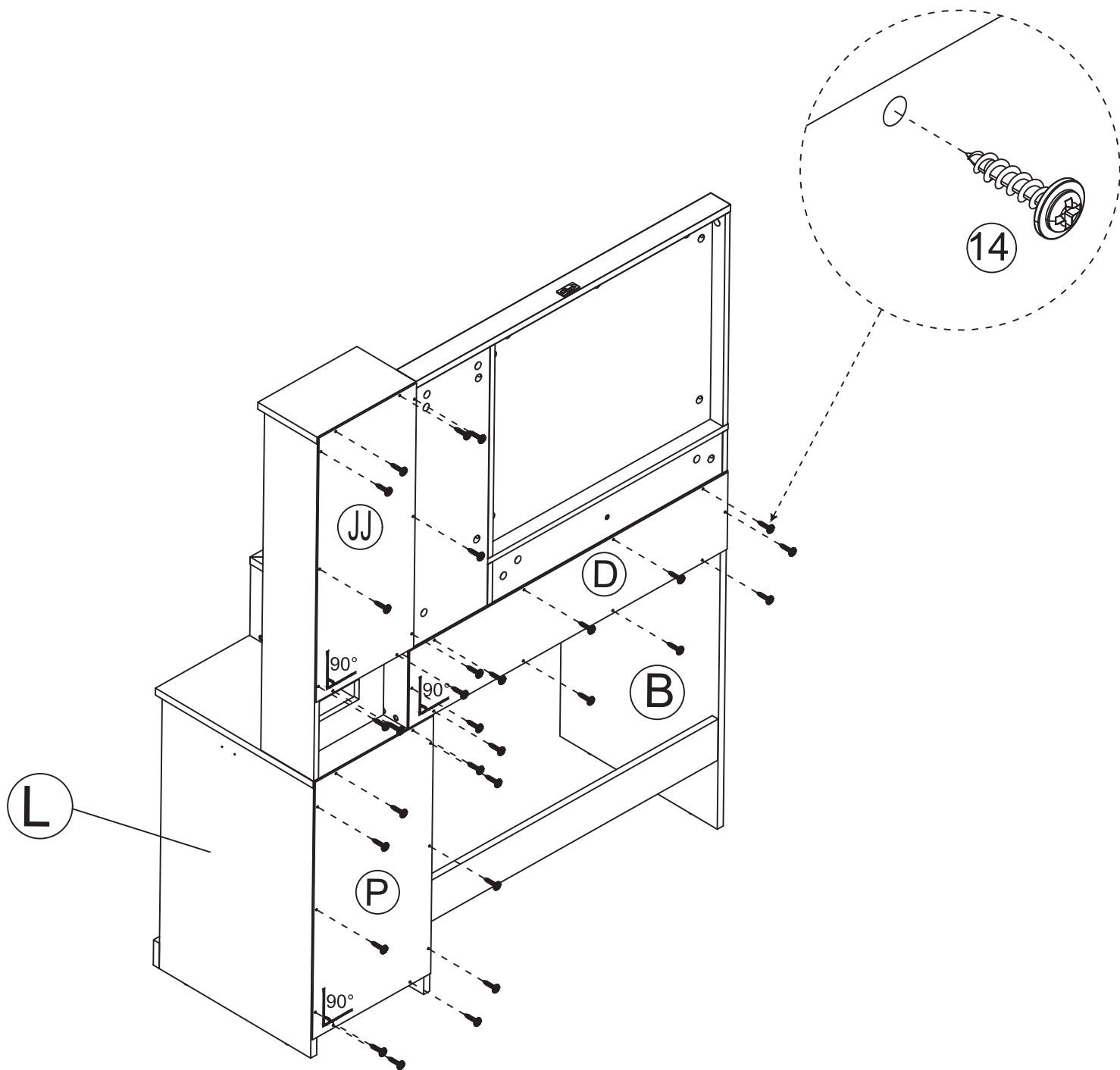
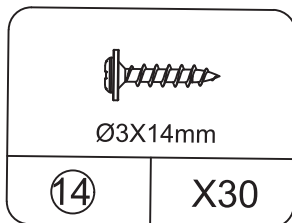
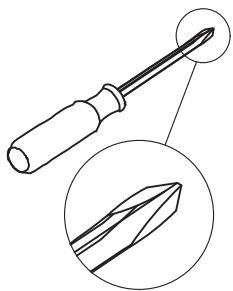

STEP40

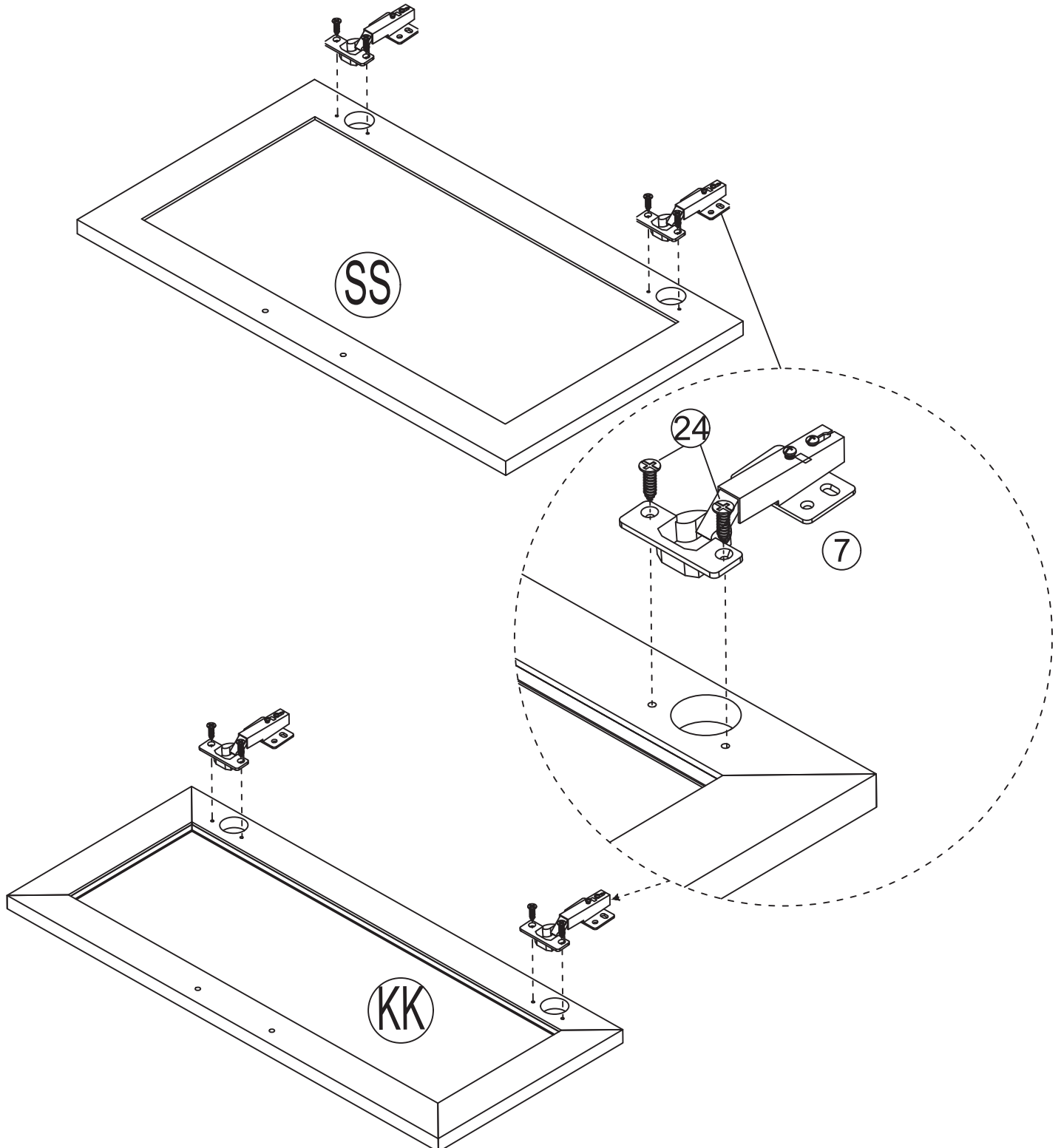
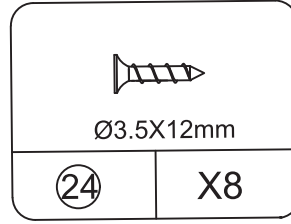
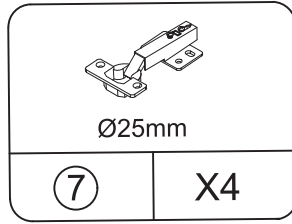
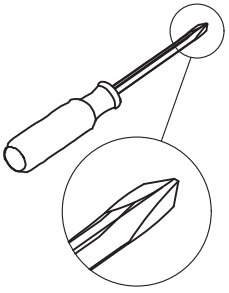

STEP 41

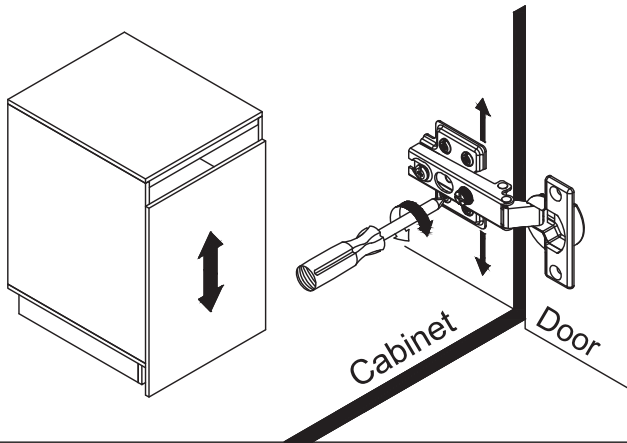
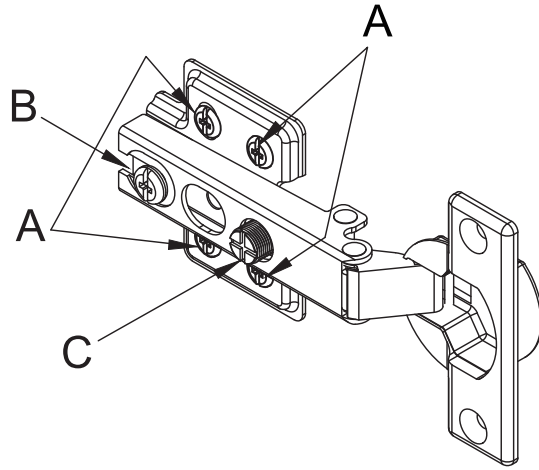

To adjust the vertical height.

Loosen the four screws "A" on both hinges. Two of them are usually in slotted holes which allows you to adjust up or down by a few mm. Then tighten back up.

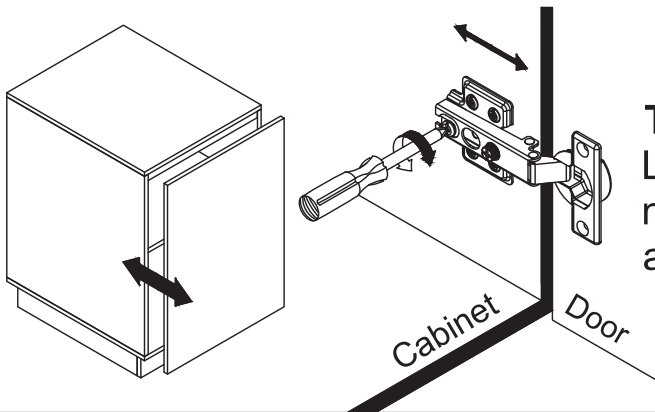

To adjust depth.

Loosen screw "B" and adjust door, if the door can not be adjusted, please loosen screw "C", then try again. Tighten screw "B" and "C".

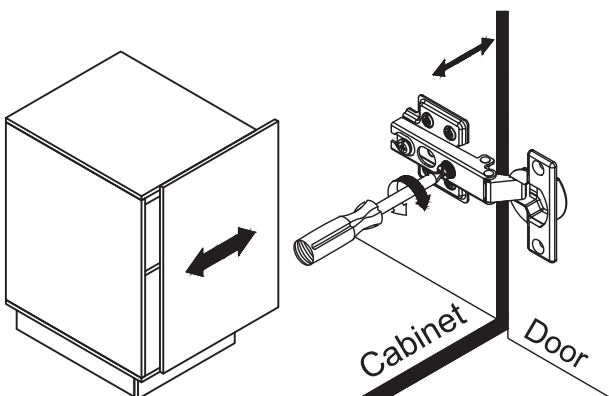

To adjust side ways.

Turning the screw "C" on BOTH hinges on each door.

STEP42

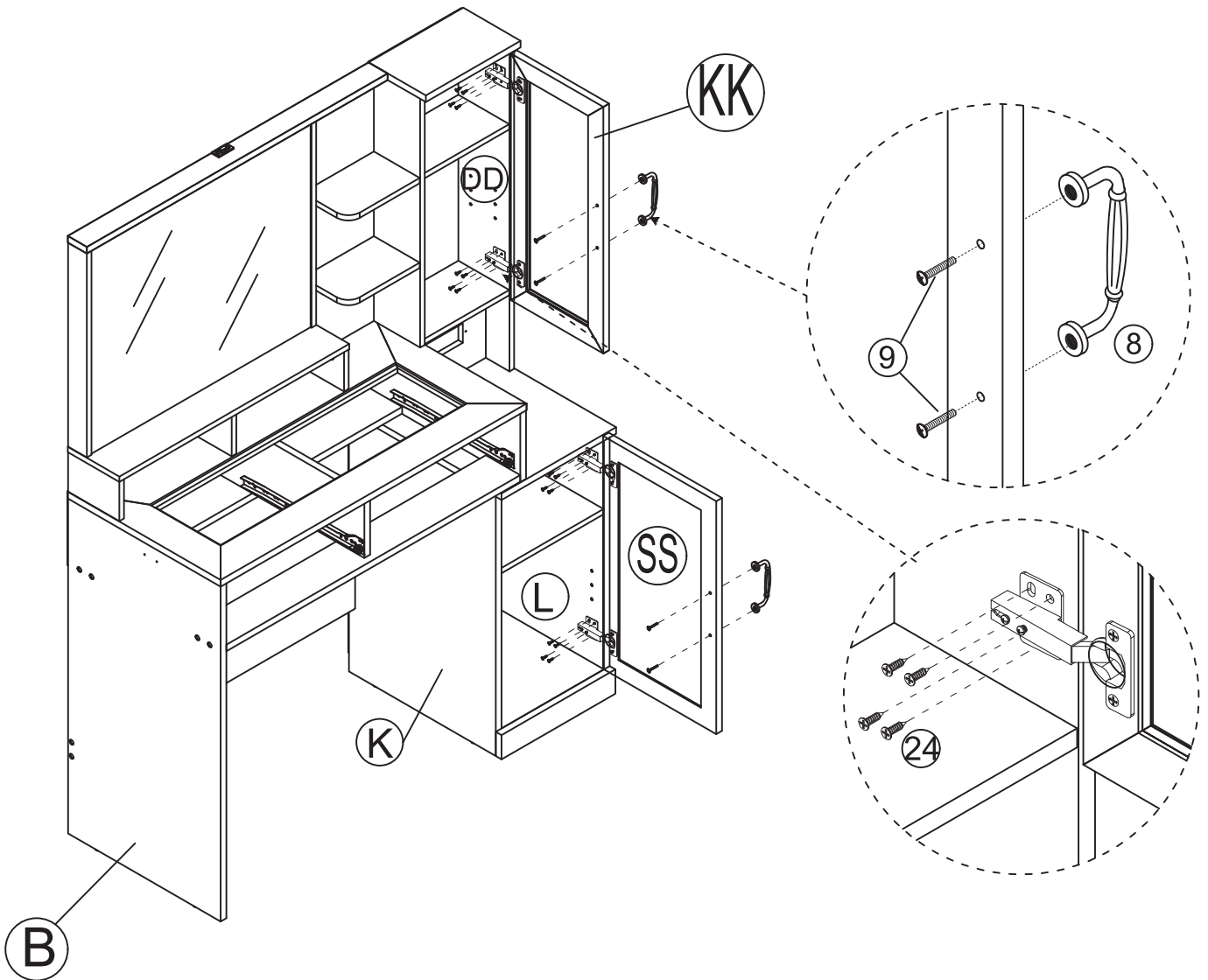
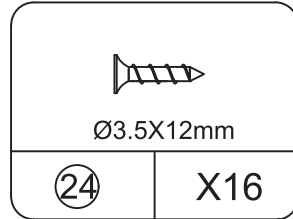
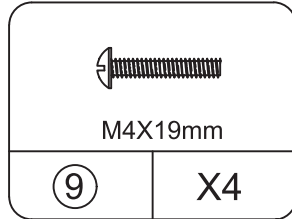
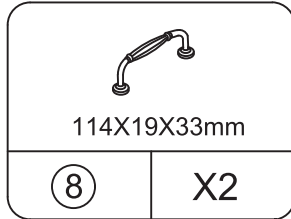
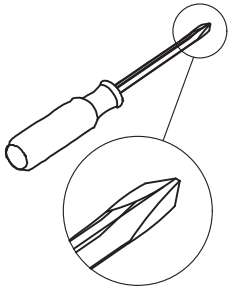

STEP43

	
Ø5X16mm	
17	X8

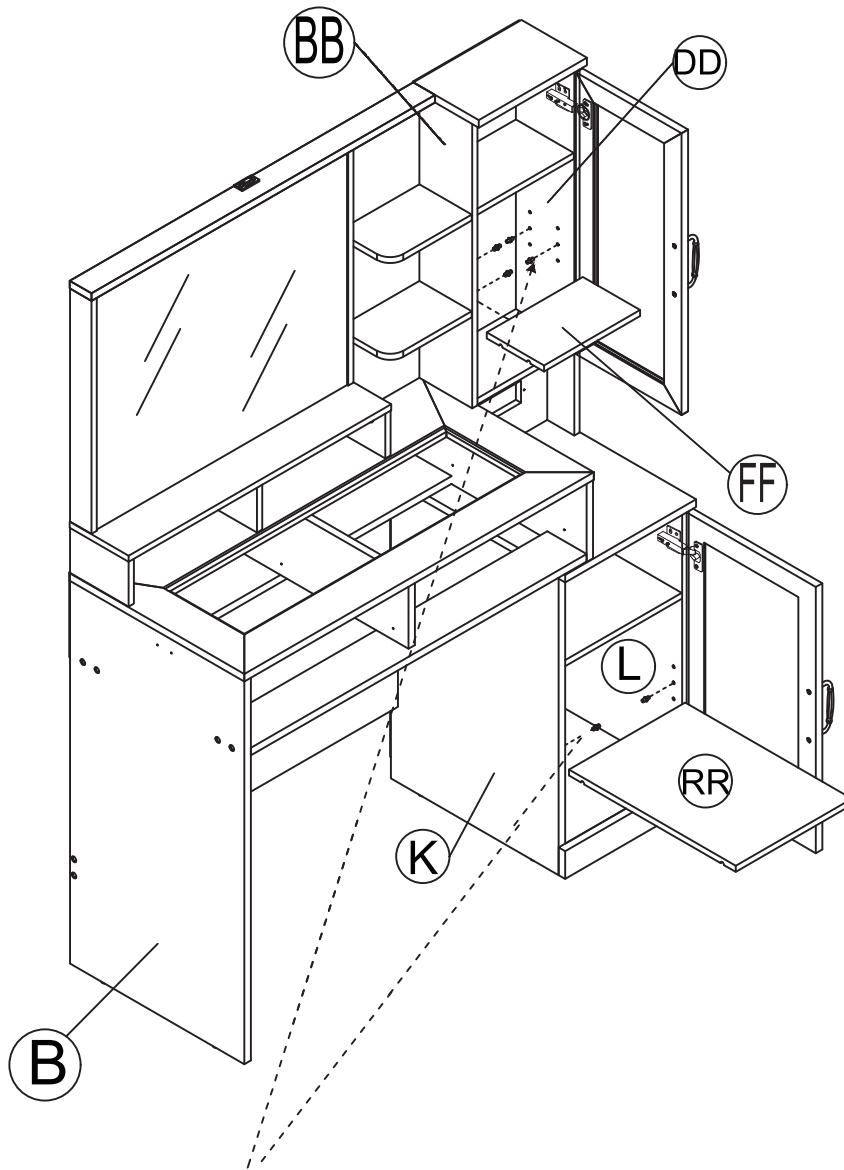

Step 1

Select the desired height and put it in

Step 2

Aim the board gaps down

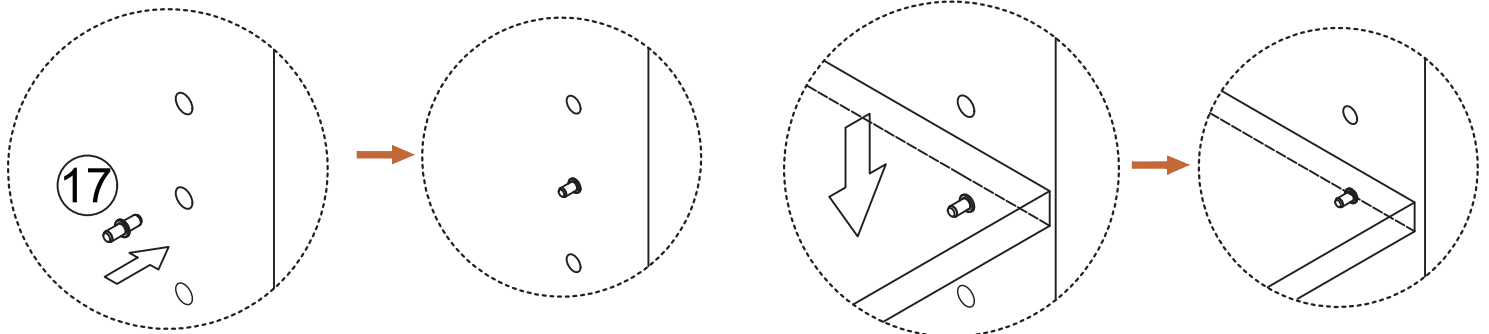

STEP44

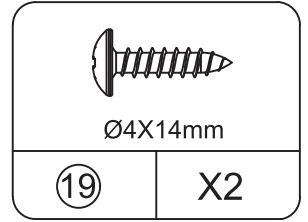
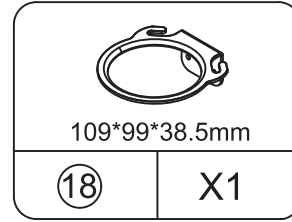
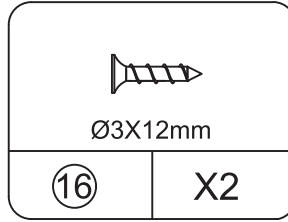
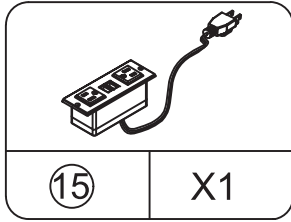
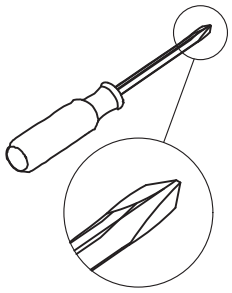

According to the needs of customers, install part 18 on the B or L board

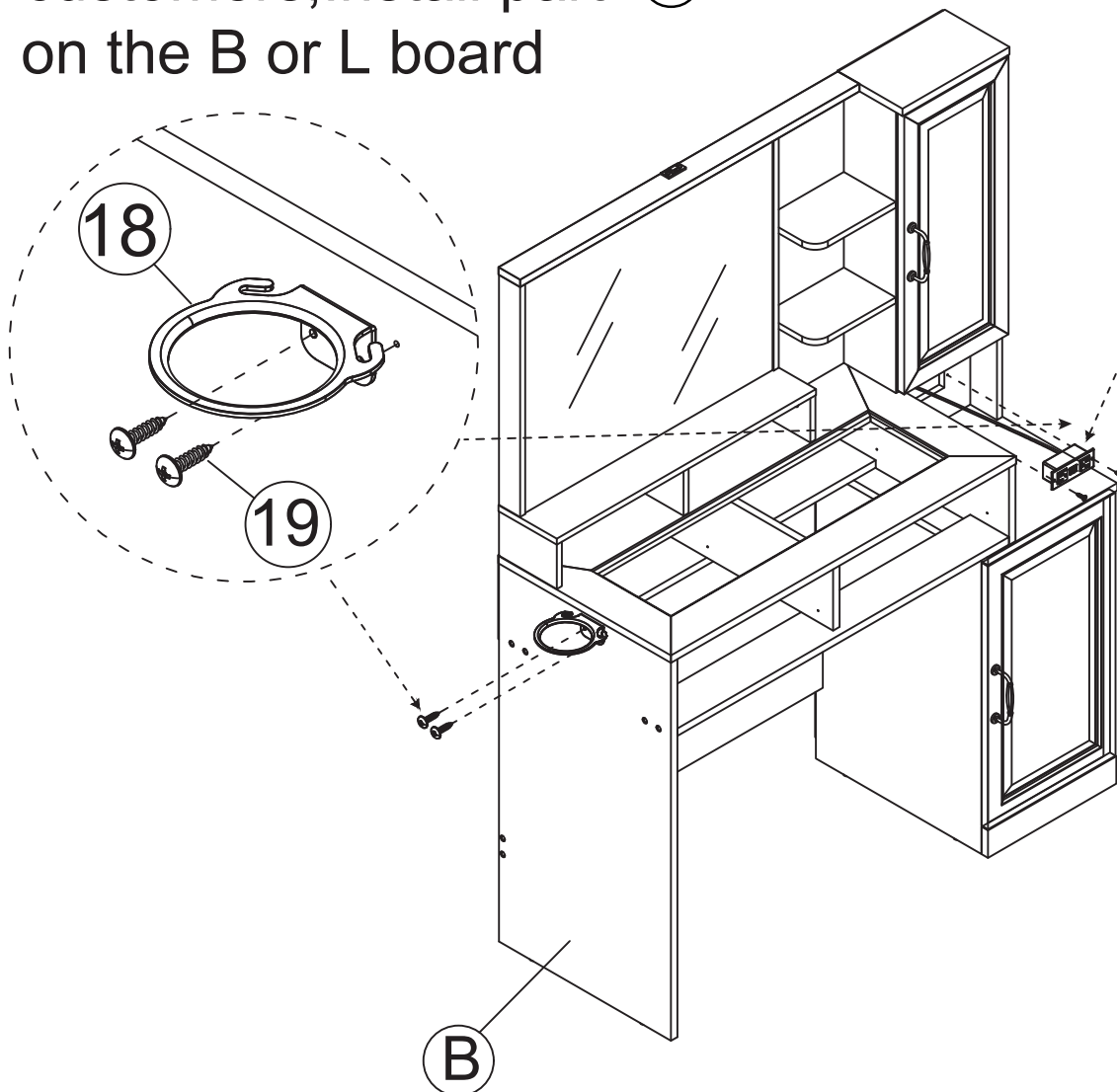

STEP45

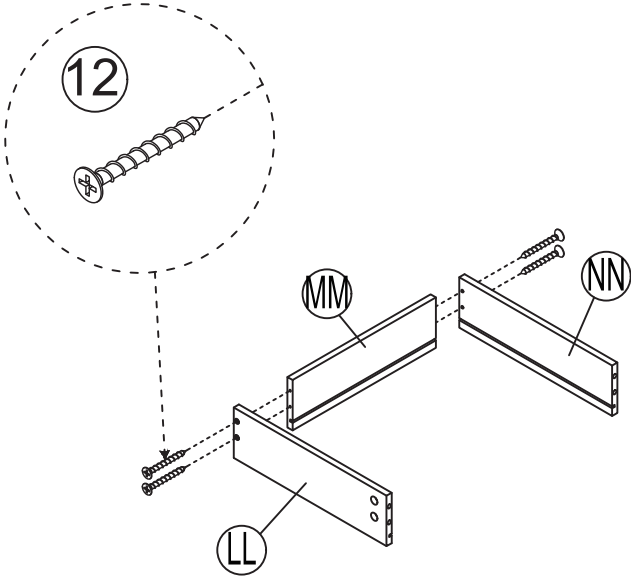
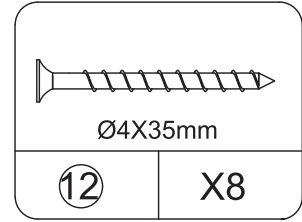
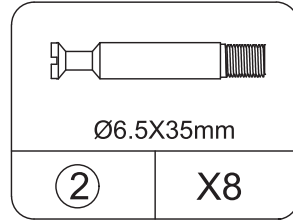
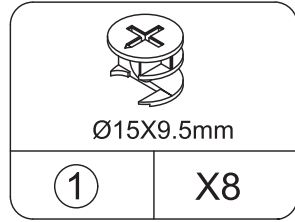
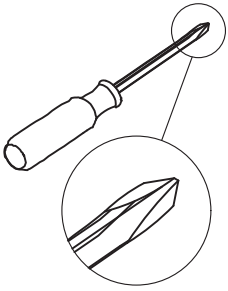

Step 1

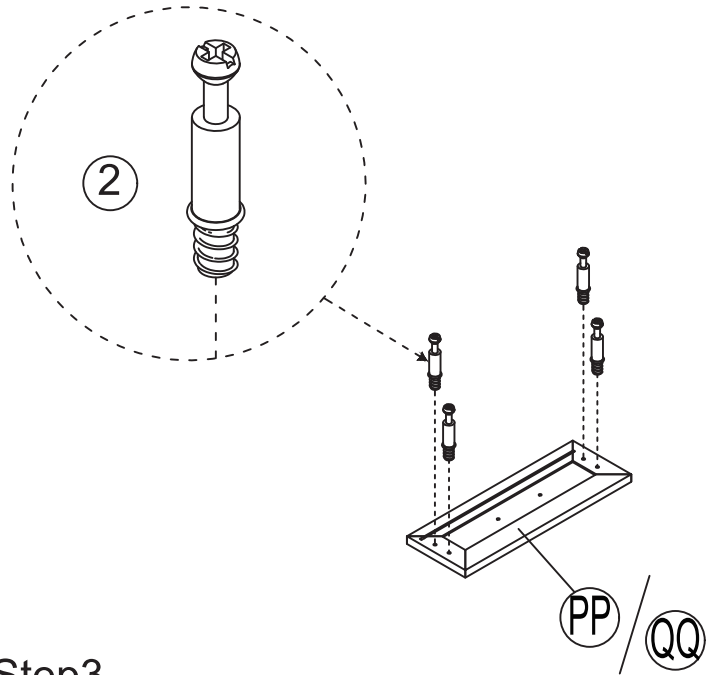

Step 3

Step 2

Step 4

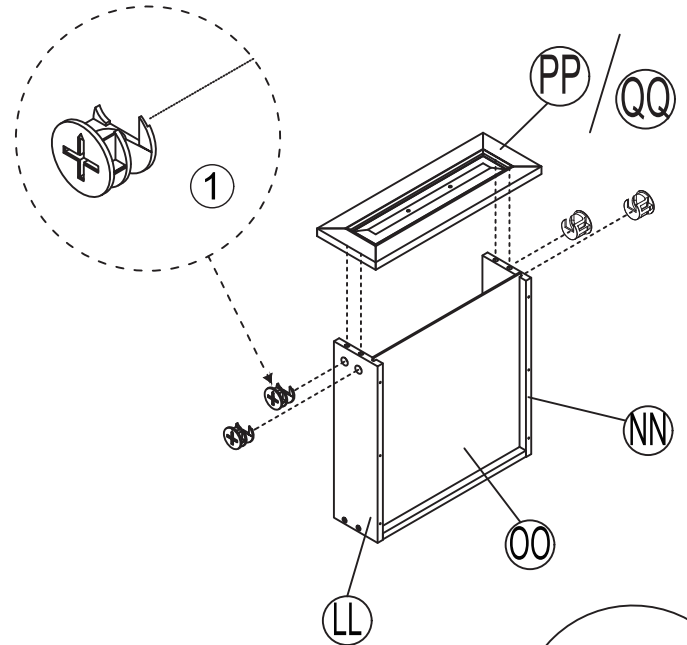
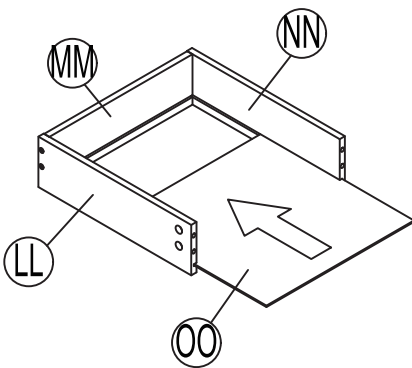

Insert the cam bolt into the hole first, then insert the cam lock and lock it.

X2

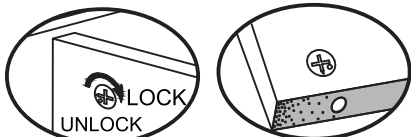

Proper orientation of CAM LOCK

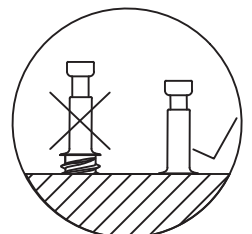

STEP46

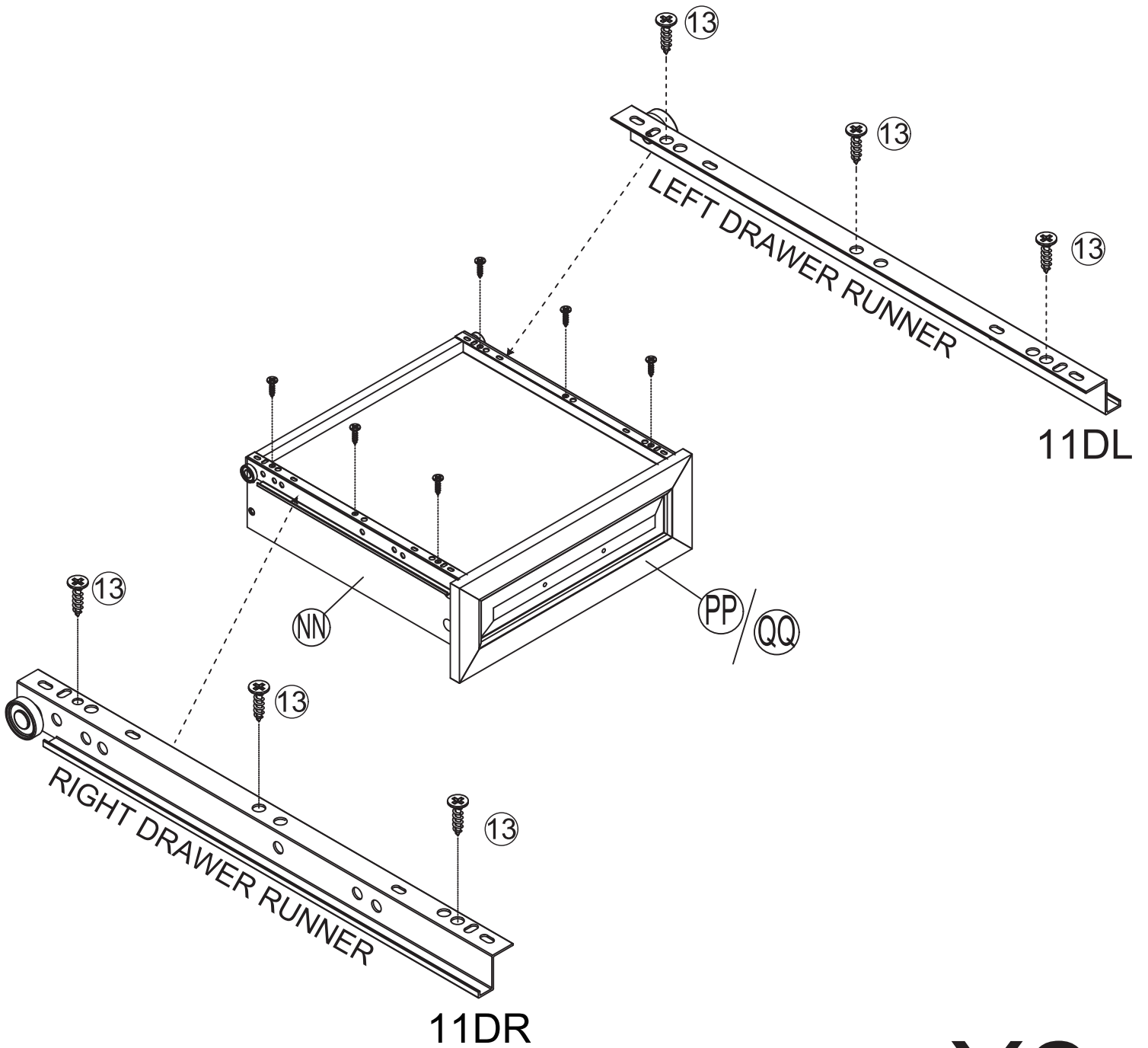
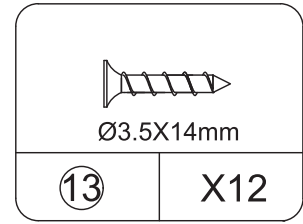
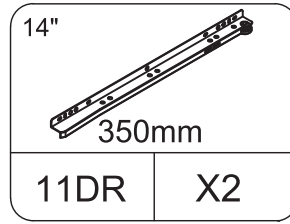
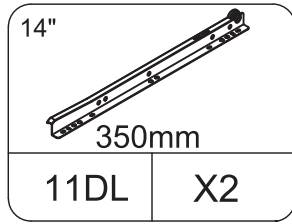
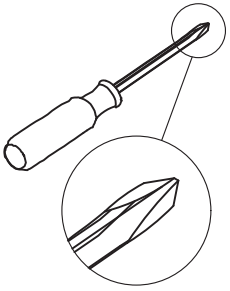

X2

STEP47

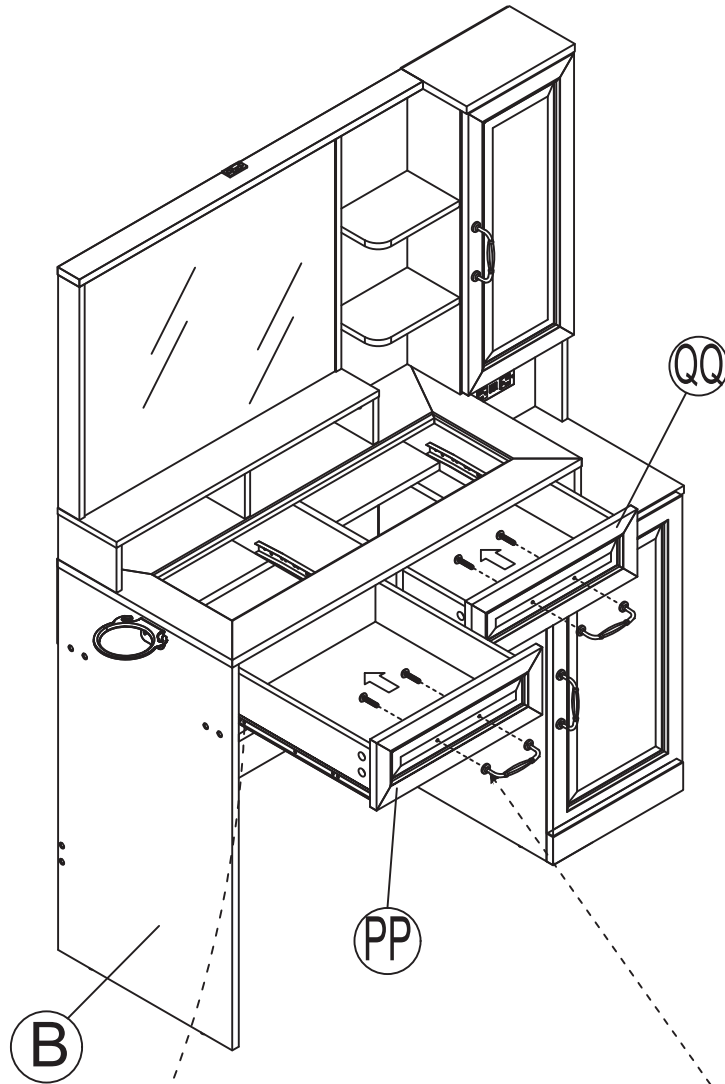
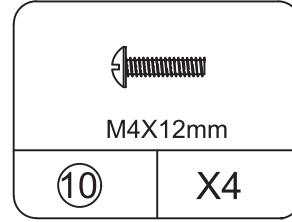
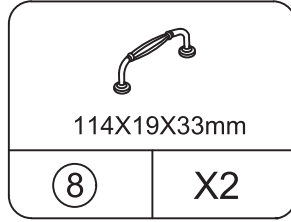
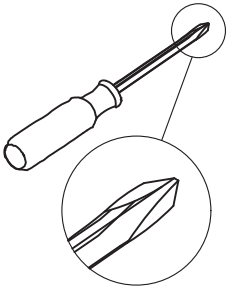

Cabinet Slide

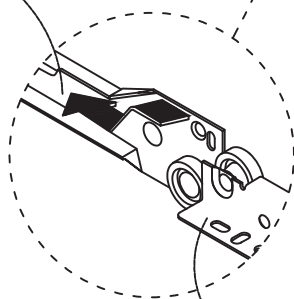

Drawer Slide

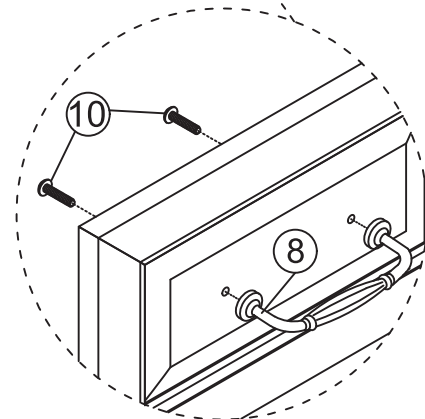

STEP48

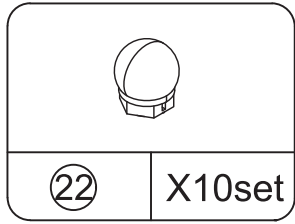

For specific installation and debugging, please read the last two pages

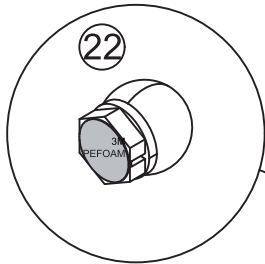

ABS lamp holder

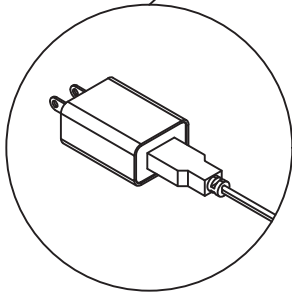

USB power adapter

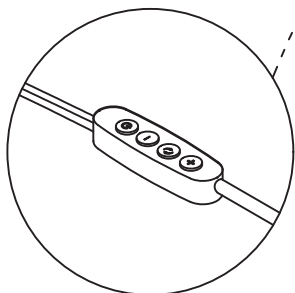

Switch regulator

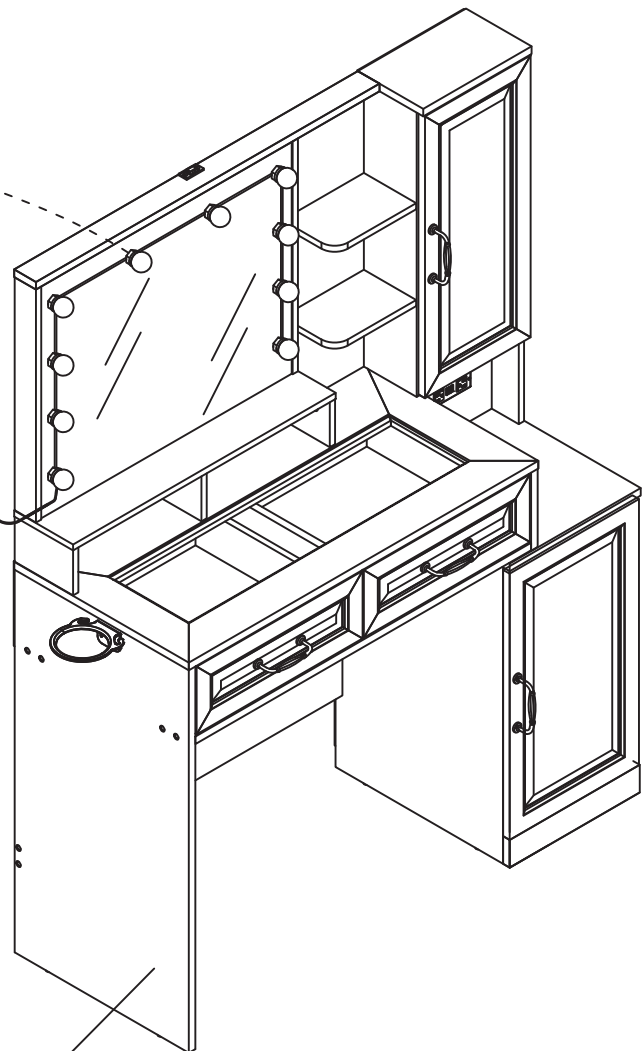

B

STEP49

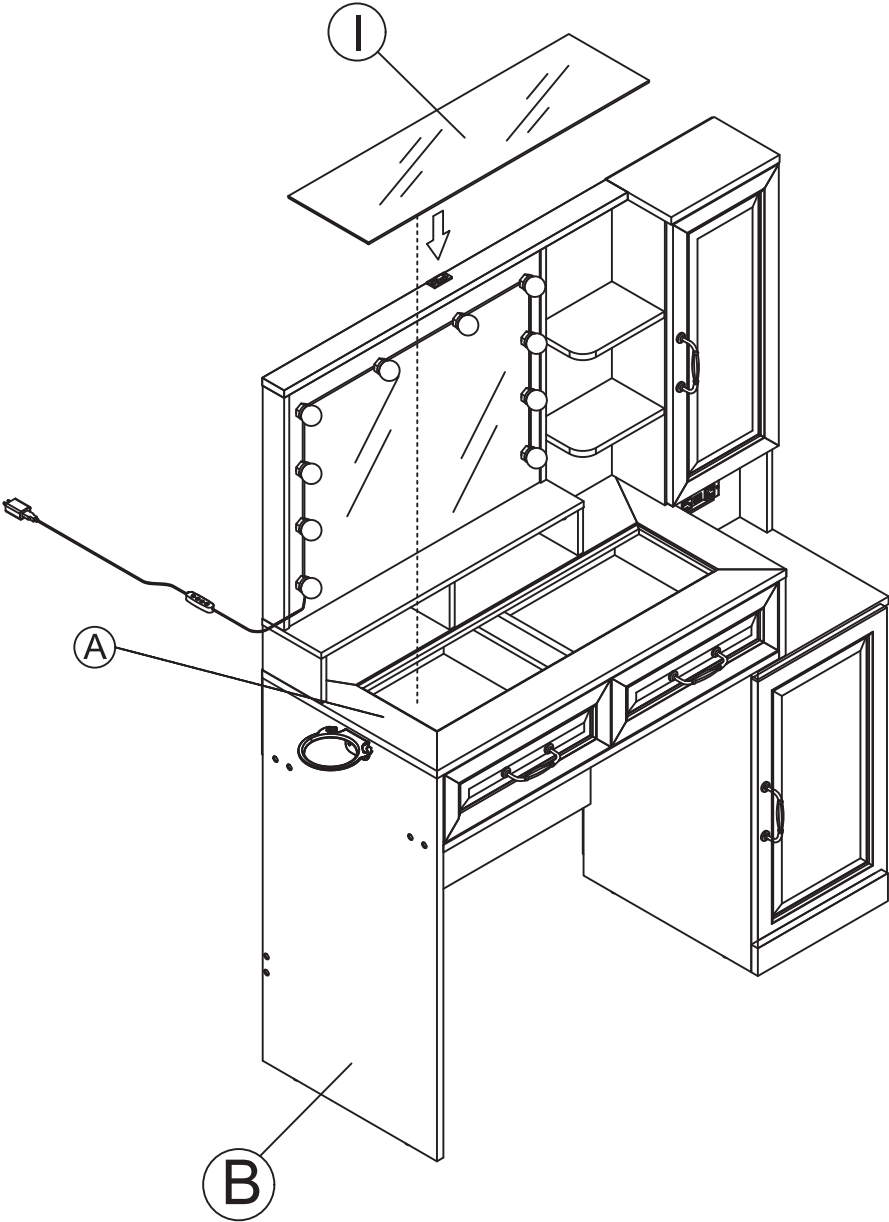

STEP50

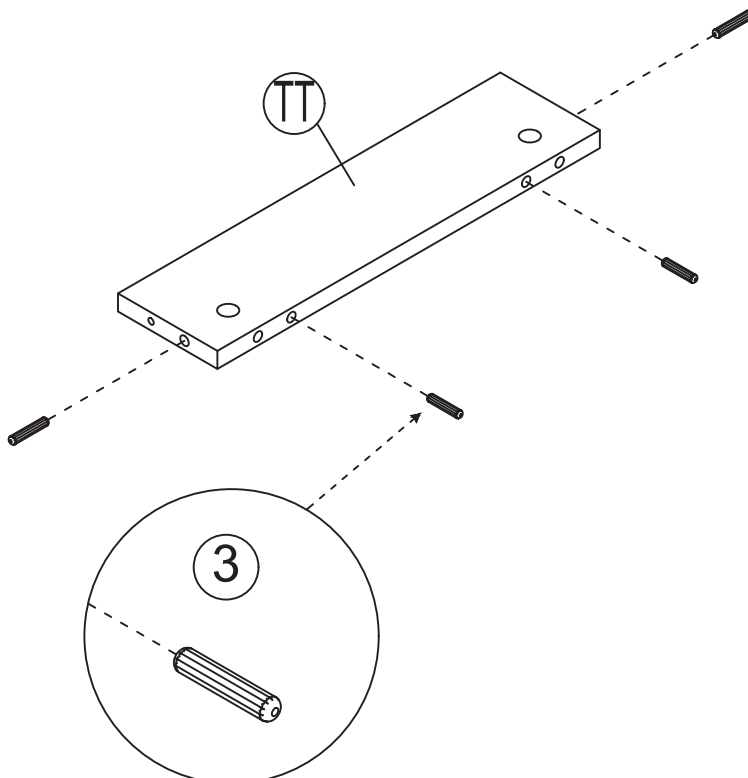
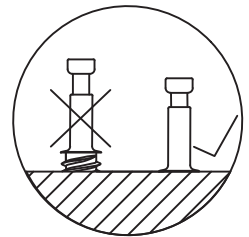
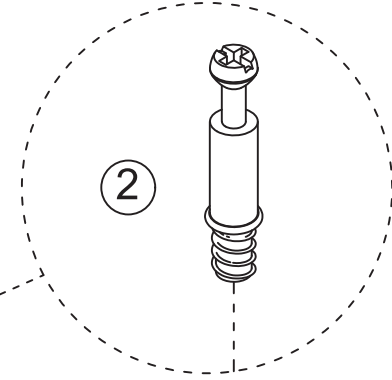
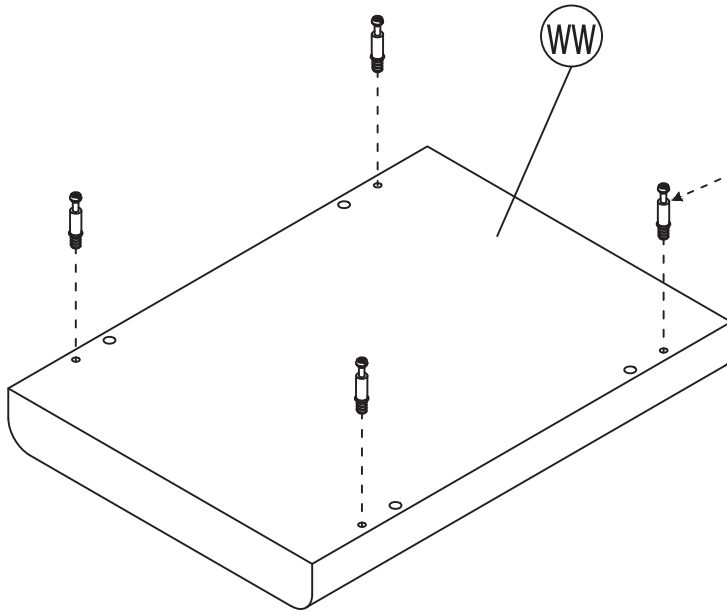
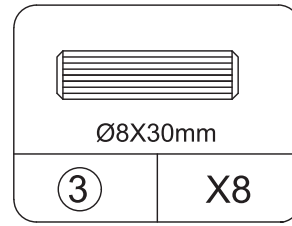
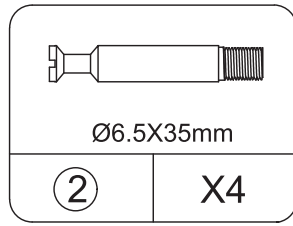
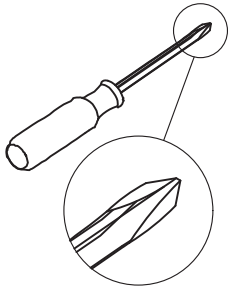

X2

STEP51

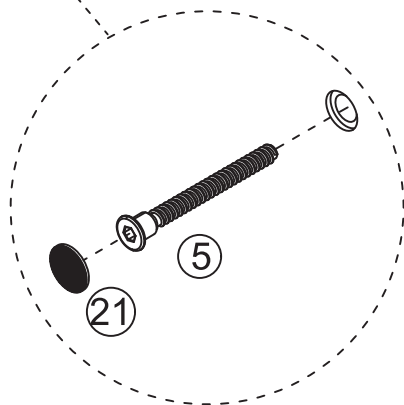
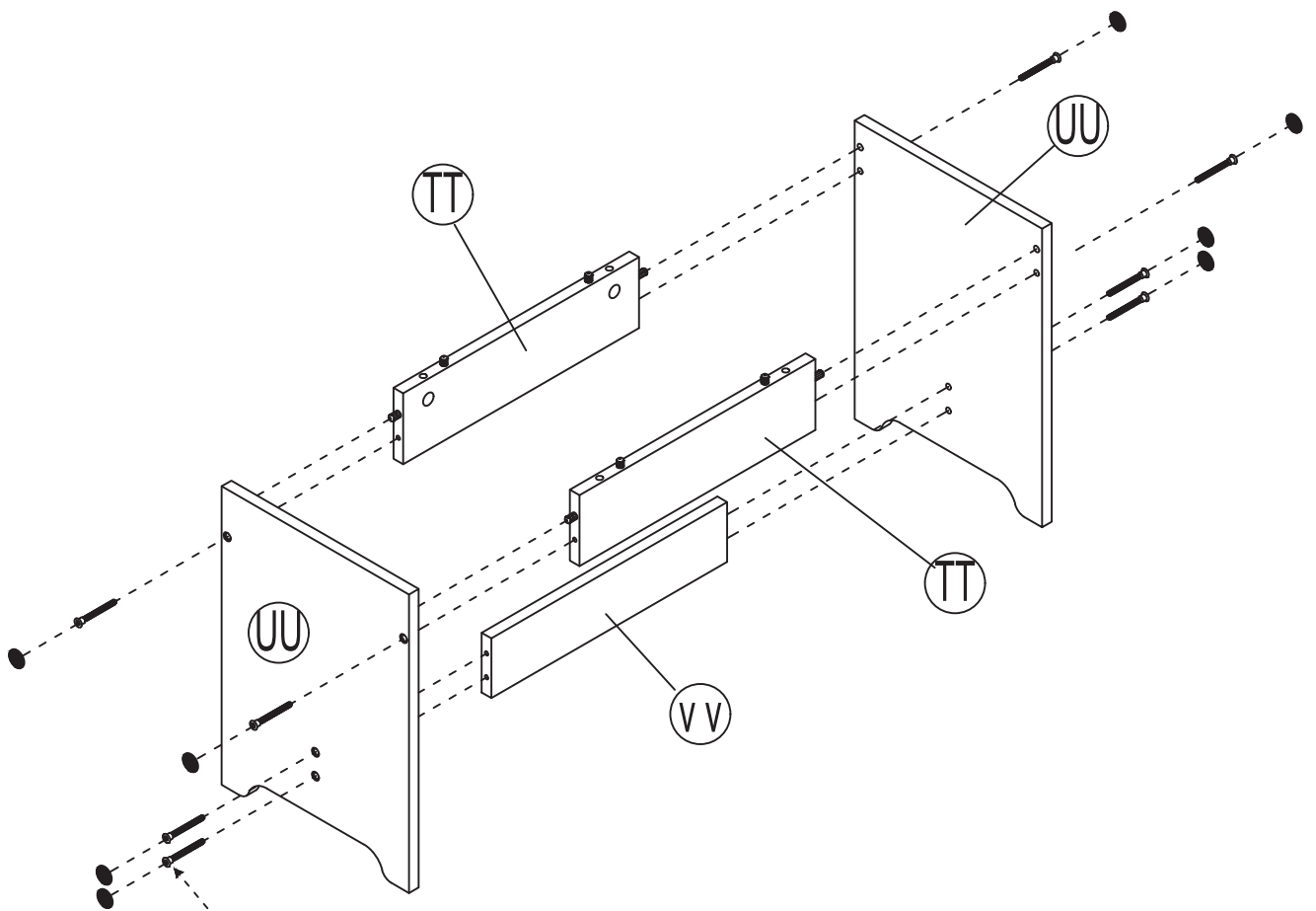
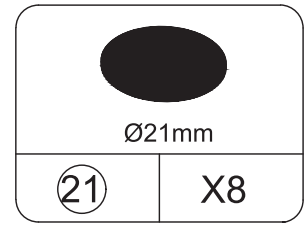
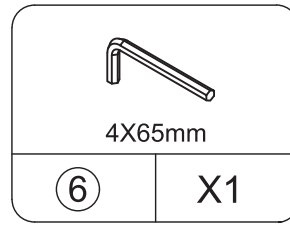
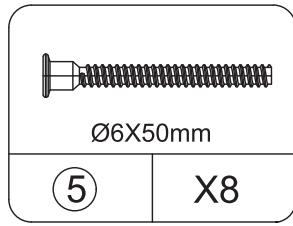
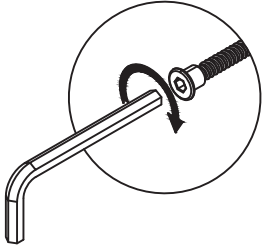

Lock first

STEP52

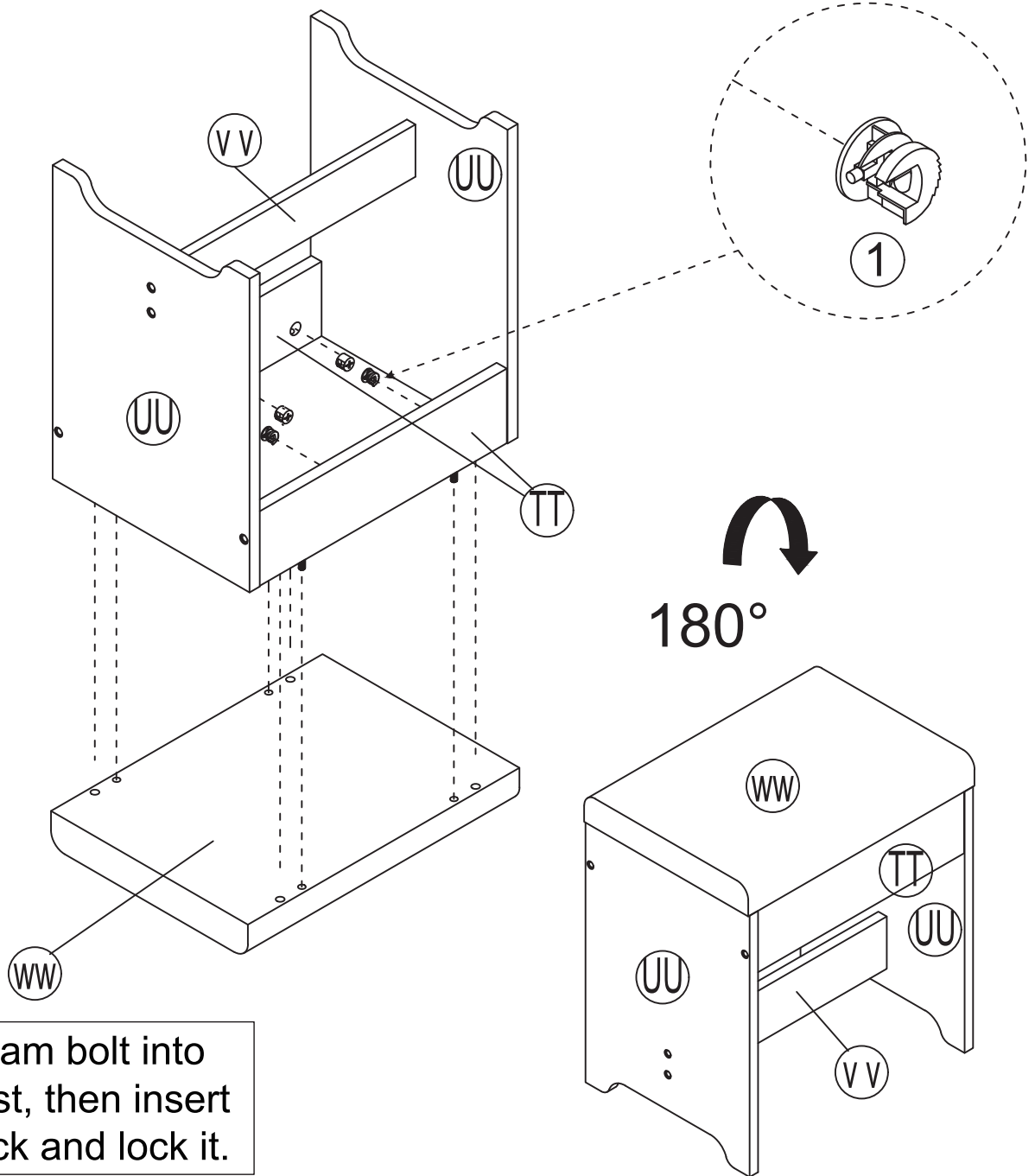
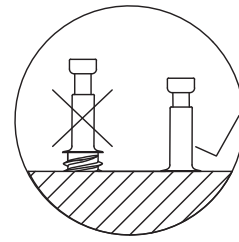
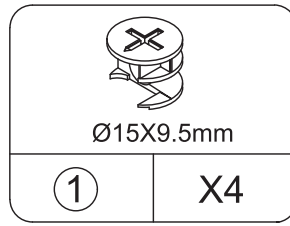
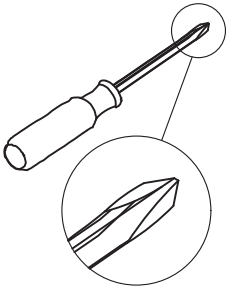

Insert the cam bolt into the hole first, then insert the cam lock and lock it.

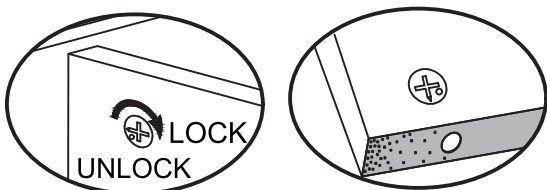

Proper orientation of CAM LOCK

STEP53

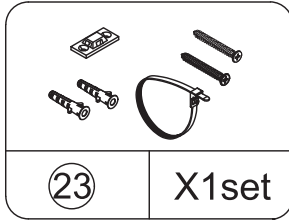
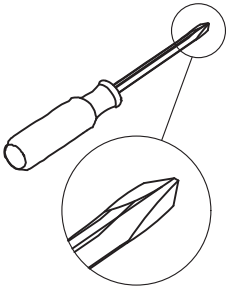

NOTE: The tipping restraint hardware included is for wooden stud wall construction. It must be attached to a wall stud. Depending upon your wall construction different anchor hardware maybe required. Please contact your local hardware store for assistance. Young children can be seriously injured by tipping furniture. You must install the tipping restraint hardware with the unit to prevent the unit from tipping, causing any accidents or damage. The tipping restraints are intended only as a deterrent and are not a substitute for proper adult supervision. The tipping restraints are not earthquake restraints. If you wish to add the extra security of earthquake restraints, they must be purchased and installed separately.



Install the tipping restraint hardware

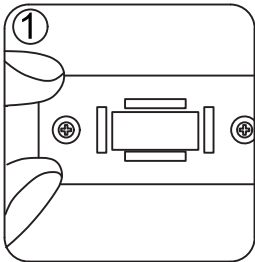

1. make mark on the wall

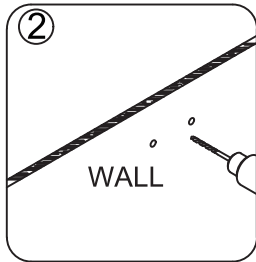

2. drill two Ø6 holes on the wall

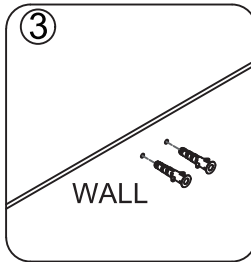

3. put two anchors in the holes

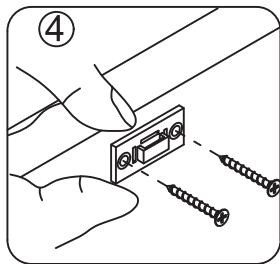
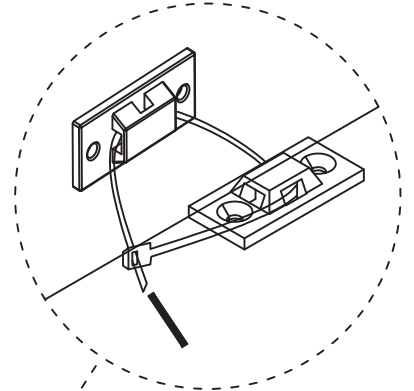

4. fix the device on the wall by the long screws

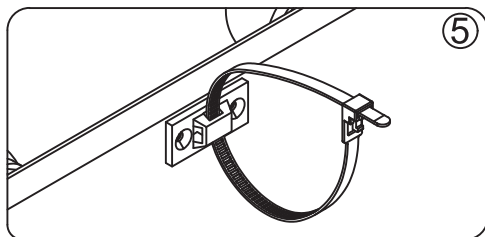

5. Push the cabinet close to the wall so that the two bases are close to each other, and then put on nylon tie to tighten it.

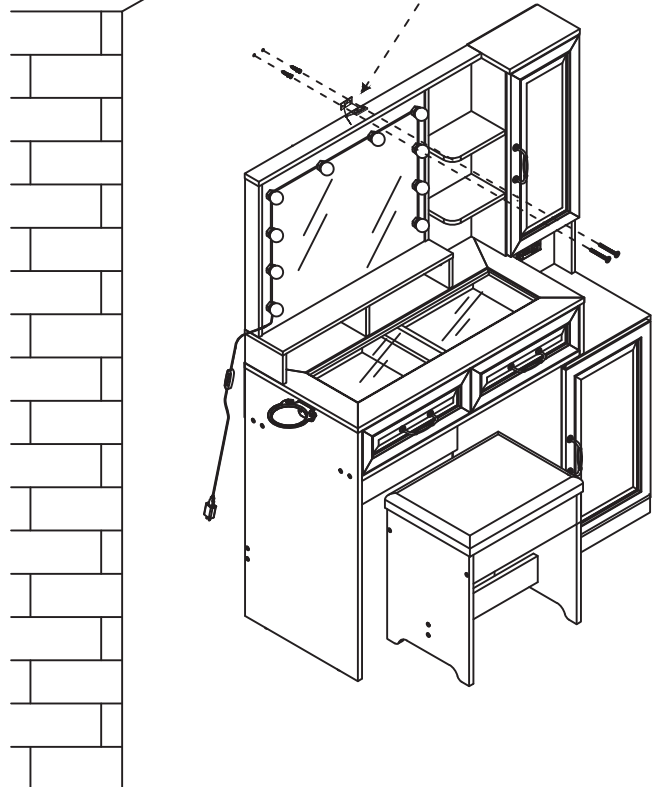

CONTINUED

Thank you for purchasing our company's DIY makeup mirror fill Light products, this product supports DIY own home mirror, instantly make their own mirror into a modern fashion makeup with LED fill mirror. Even more interesting is that you can adjust the color temperature by yourself!

Product Features:

1. The standard USB power supply, safety voltage.
2. PC soft mask, don't stab the eyes.
3. All transparent lines, beautiful and stylish.
4. Multilevel luminance adjustable, beauty skin and beauty face.
5. The color temperature is adjustable with the buttons.
6. By rotating the bulbs, the excess connecting wire can be hidden in the bottom shell make the installation more simple and beautiful.

Product parameters:

Product Name: Vanity Mirror Lights

Bulb Size: 45 X 45 X 47 mm.

Power Supply: Standard USB 5V 2A or above.

LED colour temperature: 3000K and 6500K.

Power: a single lamp maximum power is 0.8W.

Material: ABS lamp-holder and PC lampshade.

Wisdom in design:

Rotate the bulbs clockwise or anticlockwise, the ball bubble spacing becomes shorter, the connection line shrinks and hides in the ball bubble bottom cover. Simple and beautiful installation, use more comfortable.

Rest assured dressing:

USB 5V low voltage power supply, safe! Multilevel luminance adjustable, suitable for different dressing needs. Three kinds of color temperature can be adjusted: Warm White, Natural White and Pure White.

Vanity Mirror Lights
The color temperature is adjustable
Instructions

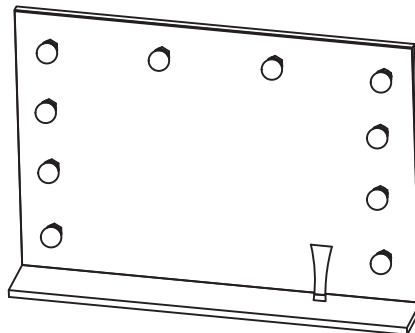

See Yourself Better!!!
Wisdom in design, Enjoy your life!

CONTINUED

Use the installation details see inside pages.

Functional Description:

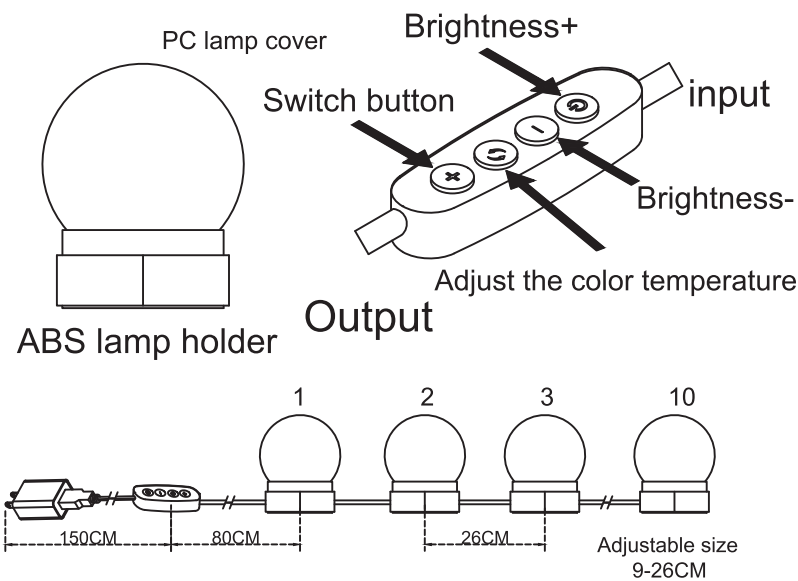

Install reference diagram:

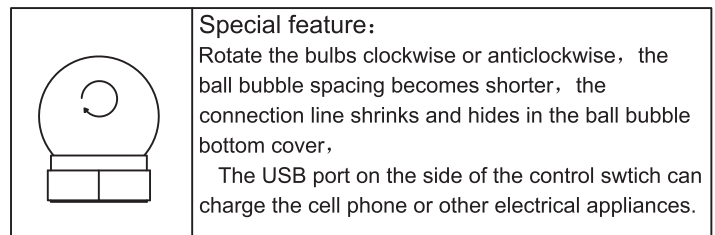
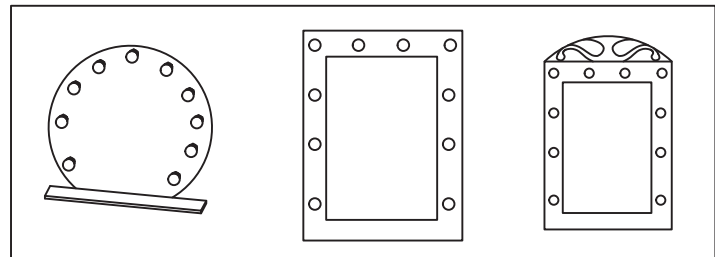

Application notes:

1. It is recommended to choose 2A or above USB power adapter, mobile phone charger and other standard USB mobile power can be use.

2. The product uses double-side adhesive paste installation of the bonding surface must be clean, dry, smooth, can not have rust and oil.

3. The wire can be adjustable through the winding between the base slot, and the bulb spacing can be adjusted between 9-26CM.

Reminded: When the bulb is pasted, please press the product for about 30 seconds, it tacks 24 hours to achieve the best adhesive strength.

See Yourself Better!!!

Installation steps:

1. Cosmetic mirror or be installed surface treatment: should be sticky surface should be try, clean, and no rust, oxidation, grease, dust and other pollutants.
2. According to the design of the number of mirrors and bulbs, each bulb installation location, note the lamp spacing of up to 26CM the minimum apacing of about 9 CM.
3. Remove the product to determine the power and control switch to place the seat is appropriate to determine the first light paste location (with the control switch to connect the first line).
4. The bottom of the product is double-side adhesive tape tear off the film, and then affixed to the first lamp position, forced down, so that double-side adhesive is pasted better. Make the tape and the bonding surface get full contact.
5. After the installation, the rotating bulbs will shrink the redundant connecting wires and hide them in the bottom shell to ensure the simple and beautiful installation and achieve the best use effect.
6. When you use the lights, you can adjust the color temperature and the brightness with the function buttons. And choose your favorite color!