



XOPOT24_

LUXURY PATIO/DECK GAS FIRE POT

PUT SOME AWESOME IN YOUR BACKYARD



XOPOT24LS



XOPOT24GR

- 65,000 BTUs
- Glass Fiber Reinforced Cement
- Manual Light Ignition
- Natural Gas (with/LP Conversion Kit Incl.)

MEMORIES - WARMTH - EXPERIENCE

Our Fire Tables and Bowls bring a heightened level of design and elegance to any outdoor space. Handcrafted from durable GFRC, our finishing process ensures each fire centerpiece is a unique creation, a beautiful and functional addition to grace any backyard or patio.

Experience the warmth your XO fire bowl can bring to your next gathering.

WORLD CLASS SERVICE | COMPREHENSIVE WARRANTIES

OUR LASTING COMMITMENT TO YOU

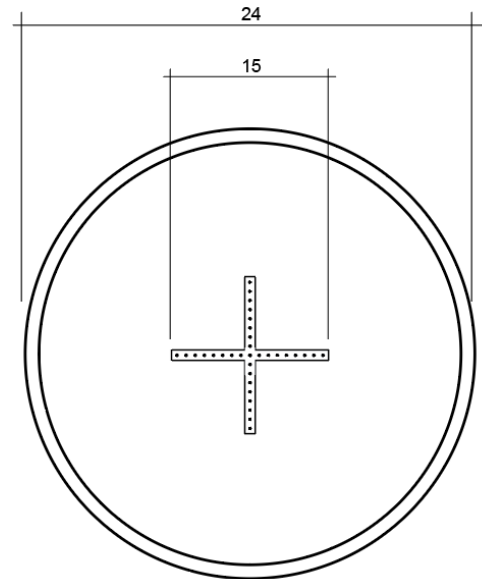
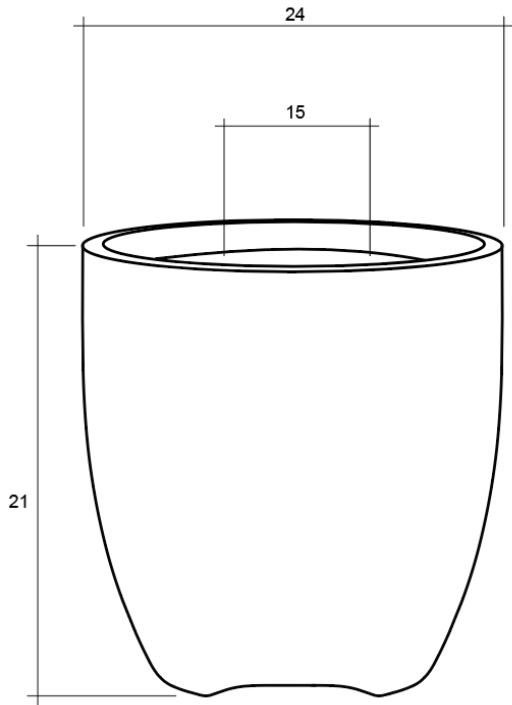

FEATURES

FINISH

Hand Crafted GFRC



Dark Gray



Limestone

FEATURES

- 304 Stainless Steel Burner
- 65,000 BTUs Maximum Output
- Available in Dark Gray and Limestone Finishes
- Individually Hand-Crafted
- Fiberglass Reinforced Durable Concrete
- Lighter than Natural Stone
- Natural Gas Standard (LP Conversion Kit Included)
- Includes 50lbs Lava Rock
- 2 Year Limited Warranty

SPECIFICATIONS

DIAMETER	24"
HEIGHT	21"
BURNER	65,000 BTU
WEIGHT	40 LBS
FUEL SOURCE	NG (LP conversion kit included)
IGNITION	Manual Light
MATERIALS	Glass fiber reinforced cement
OPTIONS	
Round Propane Encl.	XOFRNDENC20GR
Square Propane Encl.	XOFSQRENC20GR
50lbs Round Fire Rocks	XOFROCK50LBS
50lbs Lava Fire Rocks	XOFLAVA50LBS
Fire Pot Cover	XOFCOVERPOT24