











ASSEMBLY INSTRUCTION

QUEEN BED

Thank you for purchasing this quality product. Be sure to check all packing material carefully for small parts which may have come loose inside the carton during shipment. Separate, identify and count all parts and metal hardware. Compare with parts list to be sure all parts are present. If any part(s) are missing or damaged, please contact your local furniture dealer. For efficient and speedy service, please indicate the model number and code letter of part(s) needed.

*** Do not fully tighten screws until fully assembled ***

PARTS LIST				HARDWARE LIST			
NO	DESCRIPTION	SKETCH	QTY	NO	DESCRIPTION	SKETCH	QTY
A	DRAWER FRONT		2 Pcs	1	BOLT		16 Pcs
B	BACK PANEL OF DRAWER		2 Pcs	2	PHILLIP SCREW (Ø5/32"*25MM)		4 Pcs
C	SIDE PANEL OF DRAWER (R)		2 Pcs	3	PHILLIP SCREW (Ø5/32"*30MM)		16 Pcs
D	SIDE PANEL OF DRAWER (L)		2 Pcs	4	SCREW (M4*12MM)		4 Pc
E	BOTTOM SUPPORT		2 Pcs	5	KNOB		2 Pcs
F	BOTTOM PANEL OF DRAWER		2 Pcs				

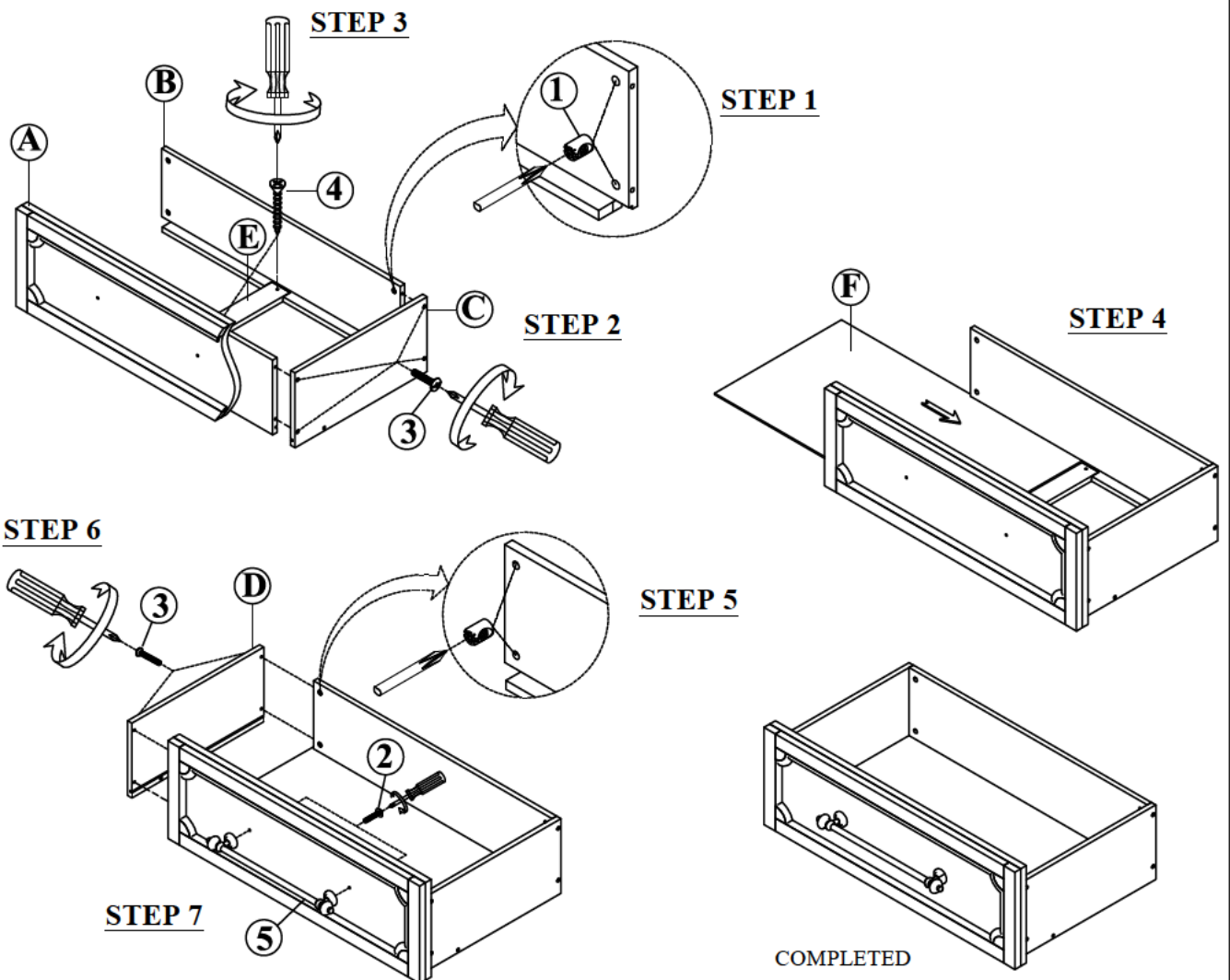







ASSEMBLY INSTRUCTION

QUEEN BED

Thank you for purchasing this quality product. Be sure to check all packing material carefully for small parts which may have come loose inside the carton during shipment. Separate, identify and count all parts and metal hardware. Compare with parts list to be sure all parts are present. If any part(s) are missing or damaged, please contact your local furniture dealer. For efficient and speedy service, please indicate the model number and code letter of part(s) needed.

*** Do not fully tighten screws until fully assembled ***

PARTS LIST				HARDWARE LIST			
NO	DESCRIPTION	SKETCH	QTY	NO	DESCRIPTION	SKETCH	QTY
G	HEADBOARD		1 Pc	6	BOLT		8 Pcs
H	FOOTBOARD		1 Pc	7	FLAT WASHER (Ø5/16*3*8MM)		8 Pcs
I	SIDE RAILS		2 Pcs	8	HEX NUT (Ø5/16*15*12MM)		8 Pcs
				9	SPANNER WRENCH (M12)		1 Pc

STEP 8

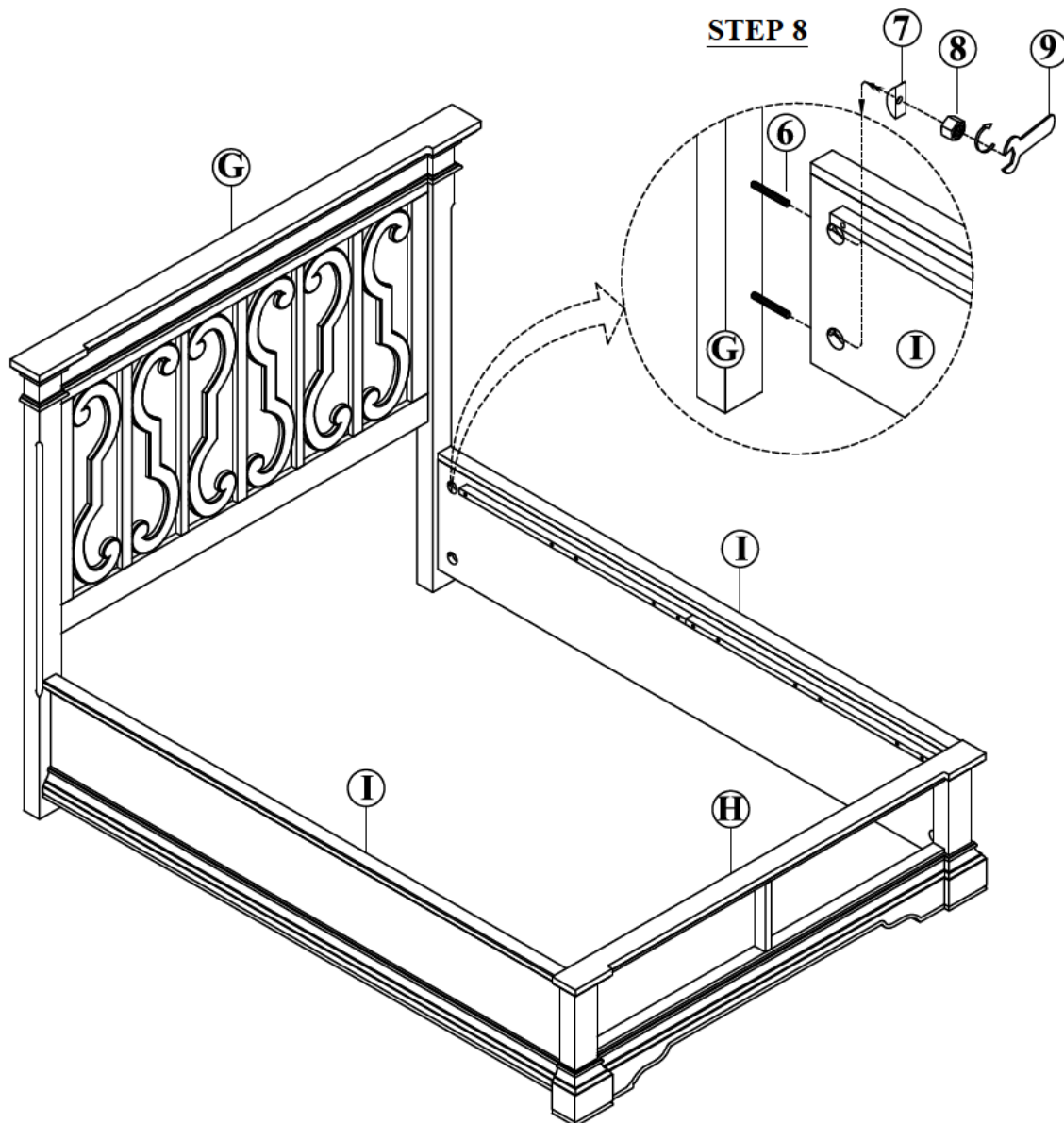

ASSEMBLY INSTRUCTION





QUEEN BED



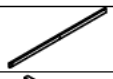

Thank you for purchasing this quality product. Be sure to check all packing material carefully for small parts which may have come loose inside the carton during shipment. Separate, identify and count all parts and metal hardware. Compare with parts list to be sure all parts are present. If any part(s) are missing or damaged, please contact your local furniture dealer. For efficient and speedy service, please indicate the model number and code letter of part(s) needed.

*** Do not fully tighten screws until fully assembled ***

PARTS LIST

HARDWARE LIST

NO	DESCRIPTION	SKETCH	QTY
J	CROSSBAR		1 Pc
K	SIDE OF THE CROSSBAR (R)		1 Pc
L	SIDE OF THE CROSSBAR (L)		1 Pc
M	SIDE OF THE CROSSBAR (MID)		1 Pc
N	SUPPORT LEG		3 Pcs

NO	DESCRIPTION	SKETCH	QTY
10	ALLEN BOLT (Ø1/4"×45MM)		15 Pcs
11	SPRING WASHER (Ø1/4"×2MM)		15 Pcs
12	SLAT WASHER (Ø1/4"×2MM)		15 Pcs
13	ALLEN KEY (M4)		1 Pc

STEP 9

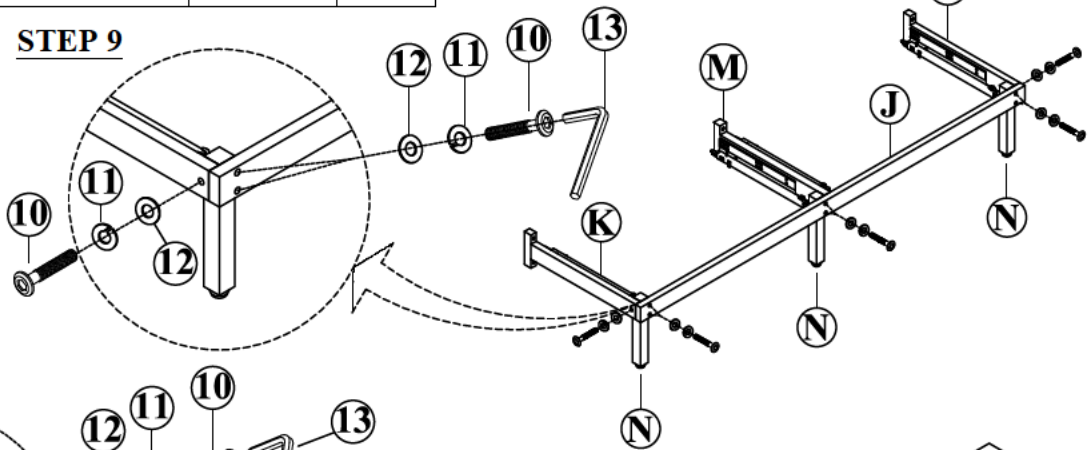

STEP 10

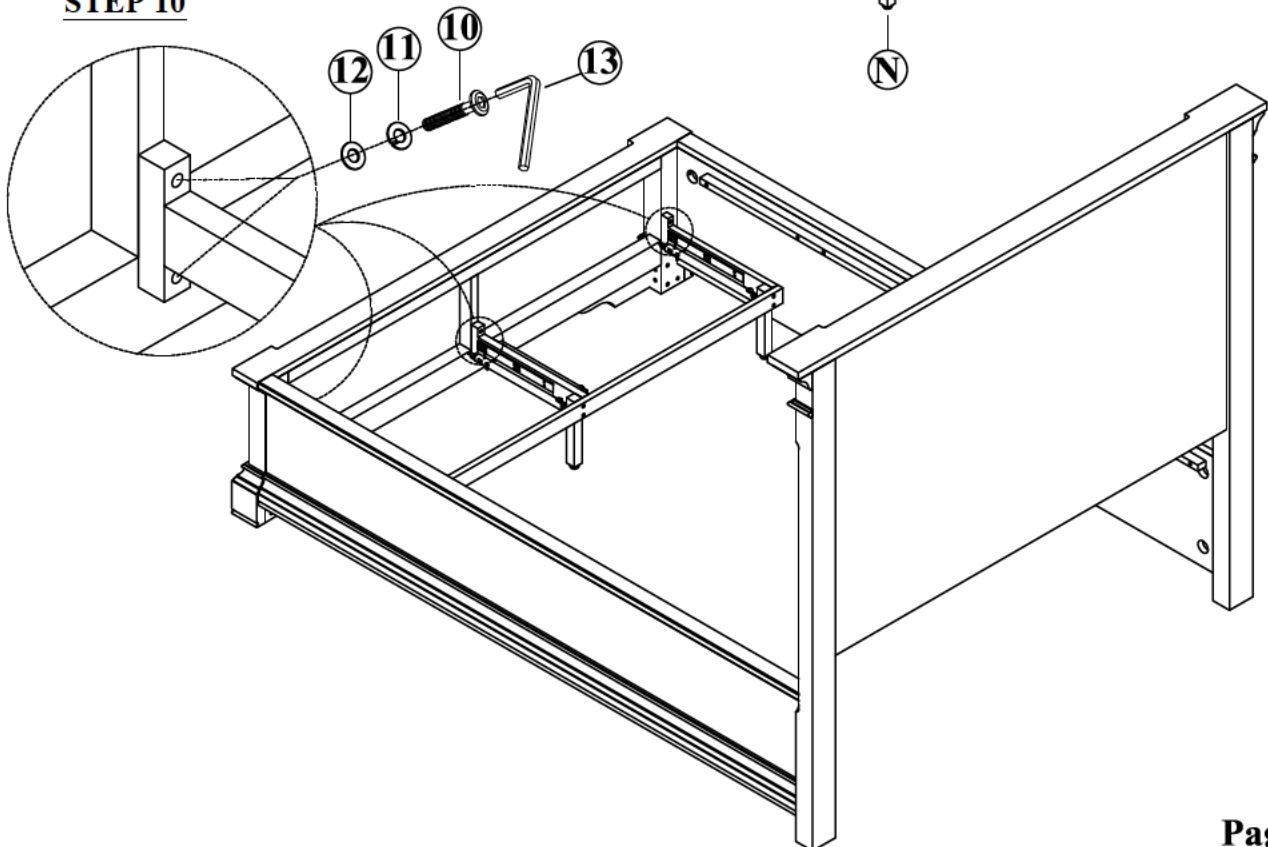

ASSEMBLY INSTRUCTION

QUEEN BED

Thank you for purchasing this quality product. Be sure to check all packing material carefully for small parts which may have come loose inside the carton during shipment. Separate, identify and count all parts and metal hardware. Compare with parts list to be sure all parts are present. If any part(s) are missing or damaged, please contact your local furniture dealer. For efficient and speedy service, please indicate the model number and code letter of part(s) needed.

*** Do not fully tighten screws until fully assembled ***

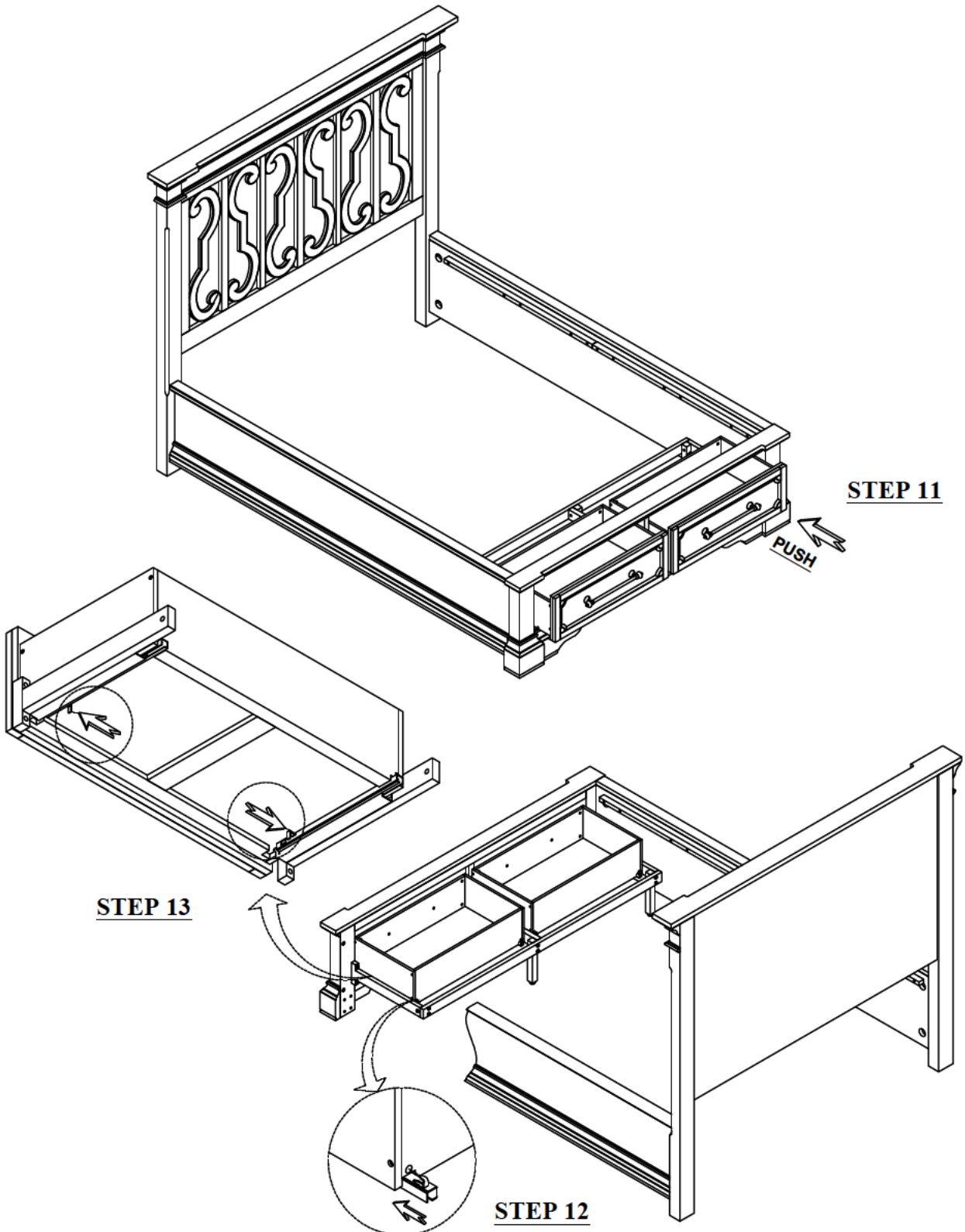



ASSEMBLY INSTRUCTION

QUEEN BED

Thank you for purchasing this quality product. Be sure to check all packing material carefully for small parts which may have come loose inside the carton during shipment. Separate, identify and count all parts and metal hardware. Compare with parts list to be sure all parts are present. If any part(s) are missing or damaged, please contact your local furniture dealer. For efficient and speedy service, please indicate the model number and code letter of part(s) needed.

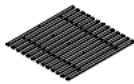
*** Do not fully tighten screws until fully assembled ***

PARTS LIST				HARDWARE LIST			
NO	DESCRIPTION	SKETCH	QTY	NO	DESCRIPTION	SKETCH	QTY
O	SIDE RAILS		1 Set	14	SCREW (M4*35MM)		26 Pcs
P	SUPPORT LEGS		4 Pcs				

