

# Assembly Instructions

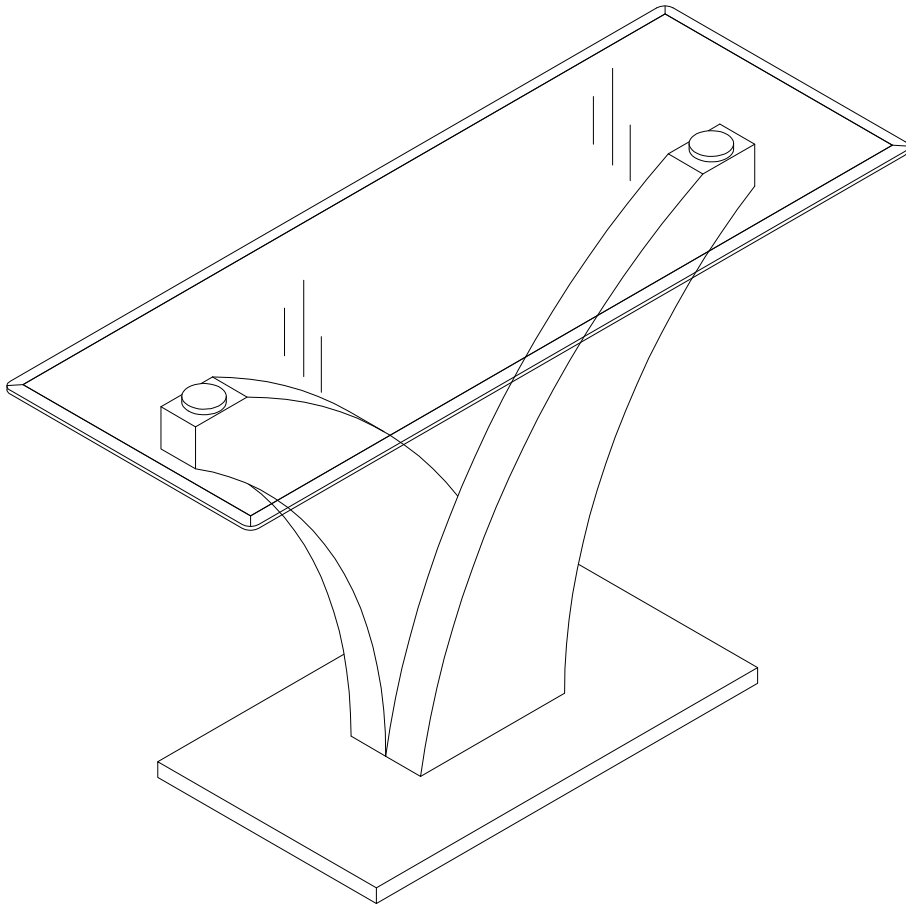

## ASSEMBLY RATING

The Assembly Rating is a 5-point system that shows the degree of effort needed in assembling a specific product (with 1 being easy and 5 being difficult). For some products, two persons are recommended.

EASY

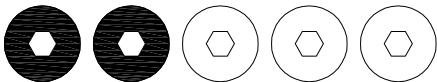

DIFFICULT

## Tools Required For Assembly:

Allen Wrench

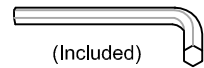

(Included)

Socket Wrench

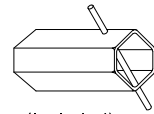

(Included)

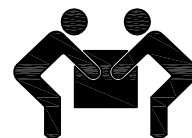

2 PERSONS RECOMMENDED

# ASSEMBLY & CARE ADVICE

FOR YOUR FURNITURE TO LAST, CORRECT ASSEMBLY AND PROPER MAINTENANCE ARE NECESSARY. PLEASE FOLLOW THE INFORMATION PROVIDED BELOW TO FULLY ENJOY YOUR FURNITURE.

## BASIC ASSEMBLY TECHNIQUES

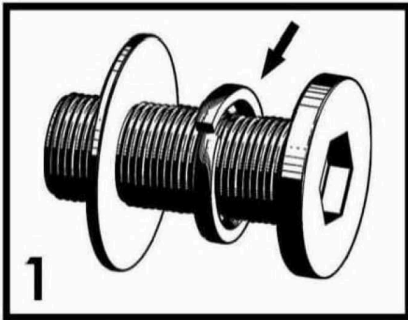

When lock or spring washer is used in an assembly, please make sure the lock or spring washer is placed between the larger flat washer and the head of the screw or bolt.

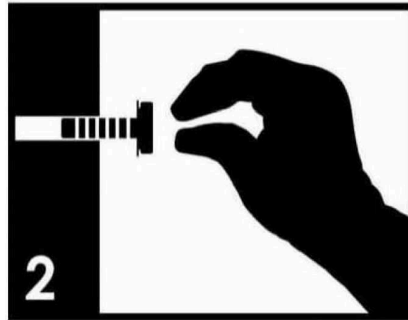

Position each part correctly and insert screws or bolts into their respective holes by hand tighten or using the proper hand tool. Only tighten when step is completed or when instructed to do so.

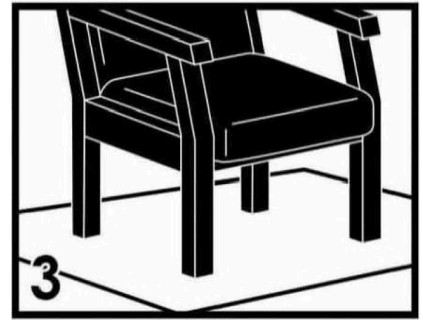

Use cardboard or carpet area when assembling furniture to prevent scratches. Make sure the furniture rests on a flat and level surface with each leg evenly touching the floor.

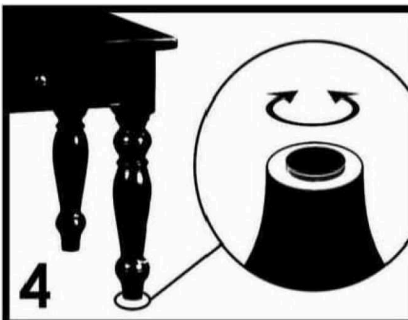

Some furniture comes with height adjustment knobs underneath each leg. To lower or to raise each leg, you need to turn clockwise or counterclockwise, respectively.

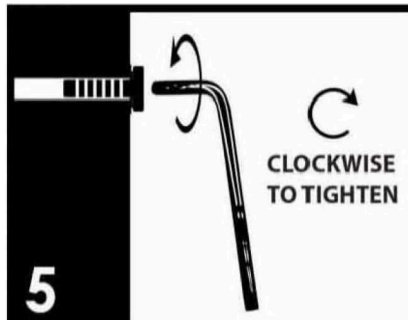

Make sure all parts are properly aligned, then use the appropriate hand tool to completely tighten the bolts or screws. Do not use power tools and do not overtighten.

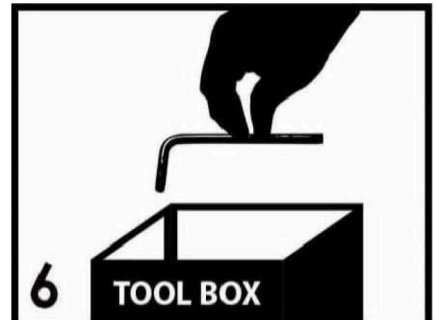

Save the instructions and store the Allen wrench or any supplied tool for later maintenance. After two weeks, check and tighten any loose hardware and repeat again every six months thereafter.

IT IS THE USER'S RESPONSIBILITY TO MAINTAIN THE FURNITURE. THE HARDWARE MAY LOOSEN OVER TIME AND MAY CAUSE THE FURNITURE TO BE WOBBLY AND UNABLE TO SUPPORT ITS INTENDED WEIGHT CAPACITY. THIS MAY LEAD TO COLLAPSE AND MAY CAUSE SERIOUS INJURY.

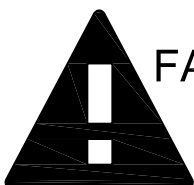

**FAILURE TO FOLLOW THE GUIDELINES ABOVE MAY RESULT IN INJURY AND/OR PROPERTY DAMAGE.**

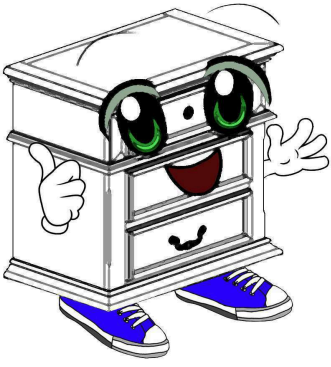

Before you begin, please read Page 2 of "Assembly and Care Advice".

And remember, do not tighten until each step is completed or instructed.

## Parts List

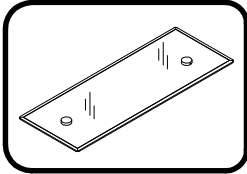

#1 x 1pc  
Top Glass

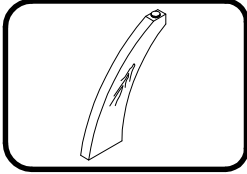

#2 x 1pc  
Right Support Leg

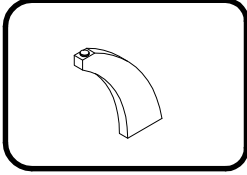

#3 x 1pc  
Left Support Leg

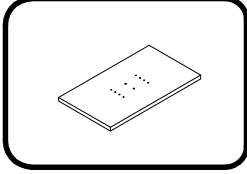

#4 x 1pc  
Bottom

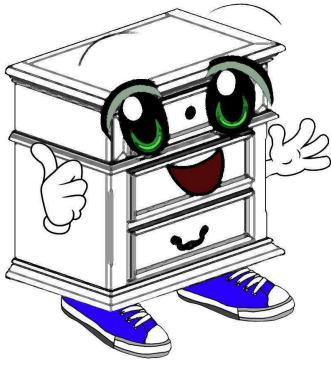

Before you begin, please read Page 2 of "Assembly and Care Advice".

And remember, do not tighten until each step is completed or instructed.

### Hardware List



#A x 8pcs  
Bolt 1/4" X 1-3/4"



#B x 6pcs  
Adjustable Foot

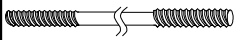

#C x 2pcs  
Rod 5/16" X 4"



#D x 8pcs  
Washer Ø18xØ6x1.5



#E x 1pc  
Allen Wrench M4

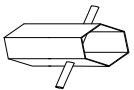

#F x 1pc  
Socket Wrench



#G x 2pcs  
Wood Dowel Ø8 X 30



#H x 2pcs  
Washer Ø18 X Ø9 X 2.0



#I x 2pcs  
Nut M8



#J x 1pc  
White Cover Ø30



#K x 1pc  
Grey Cover Ø30



#G x 2pcs

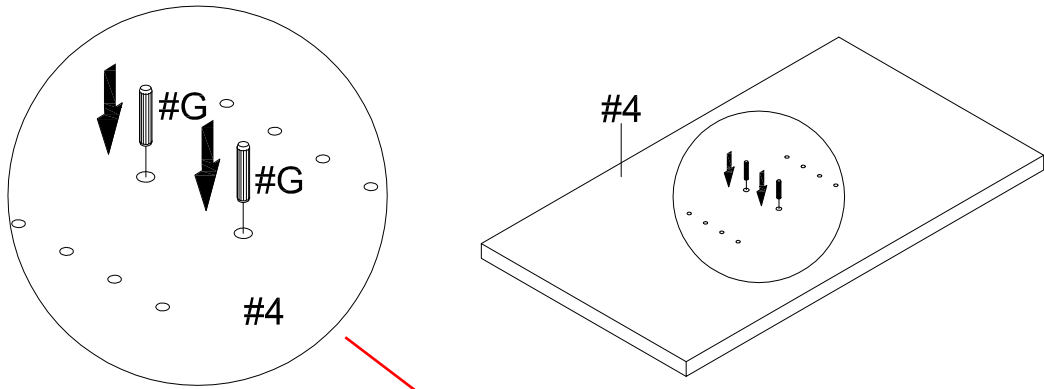

Insert 2 wood dowels (#G) to the holes in the center of the bottom panel (#4) as shown in the picture.



#A x 8pcs  
#B x 6pcs  
#D x 8pcs

1) Attach support legs (#2,3) to the bottom panel (#4). Make sure the legs are attached through the wood dowels.

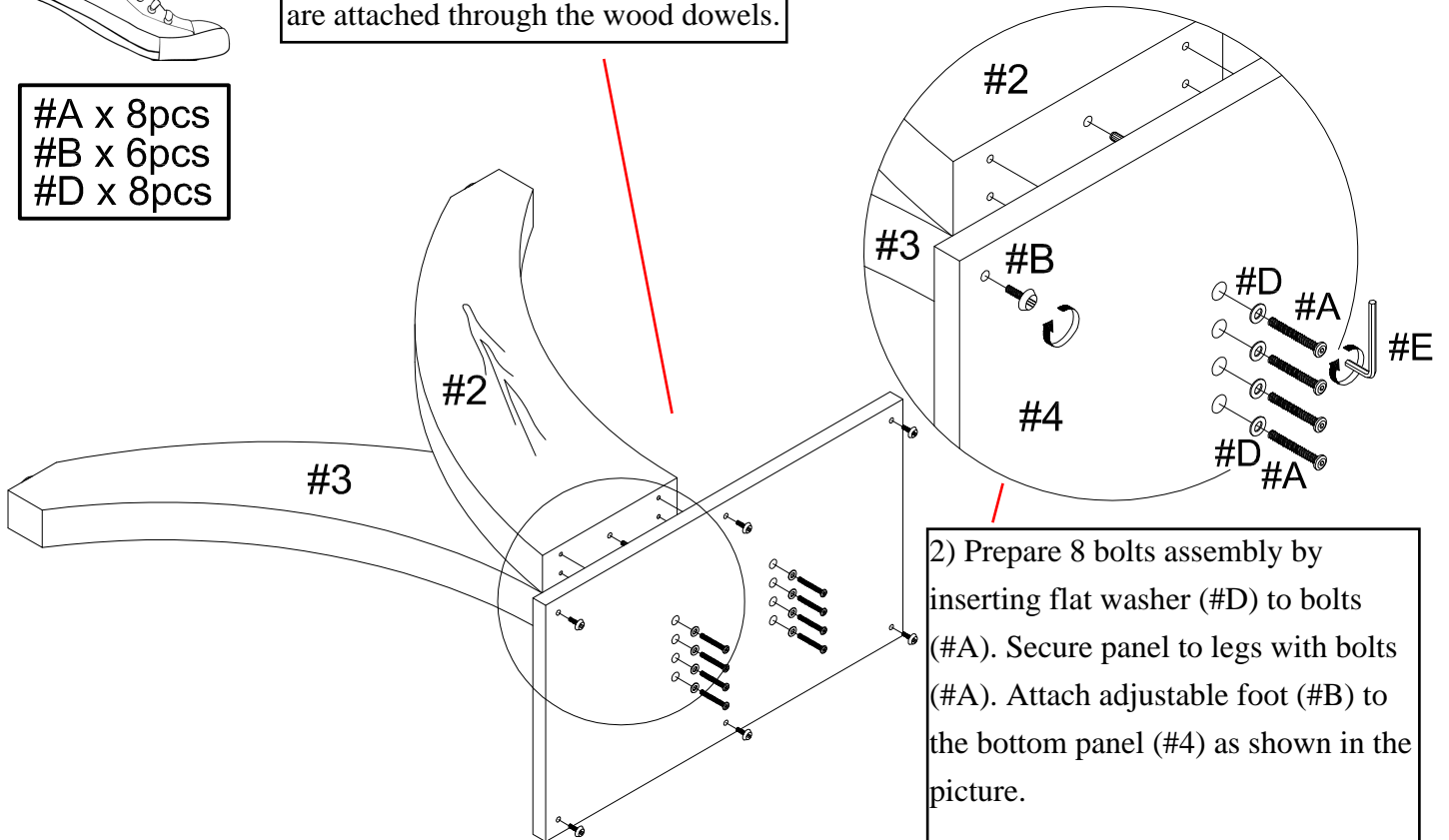

2) Prepare 8 bolts assembly by inserting flat washer (#D) to bolts (#A). Secure panel to legs with bolts (#A). Attach adjustable foot (#B) to the bottom panel (#4) as shown in the picture.



#3

#C x 2pcs  
#H x 2pcs  
#I x 2pcs

1) Insert rod (#C) to the glass top (#1), then align the base so that the rods (#C) pit through the hole as shown in the picture.

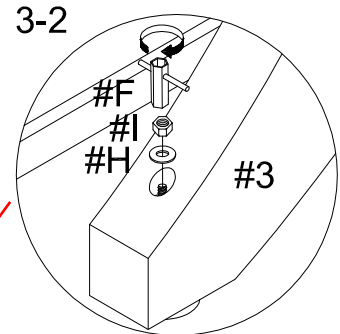
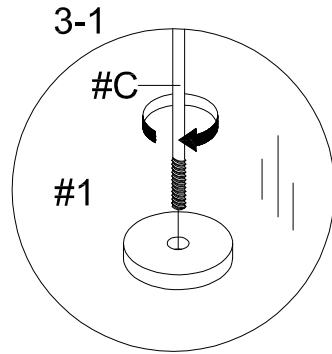
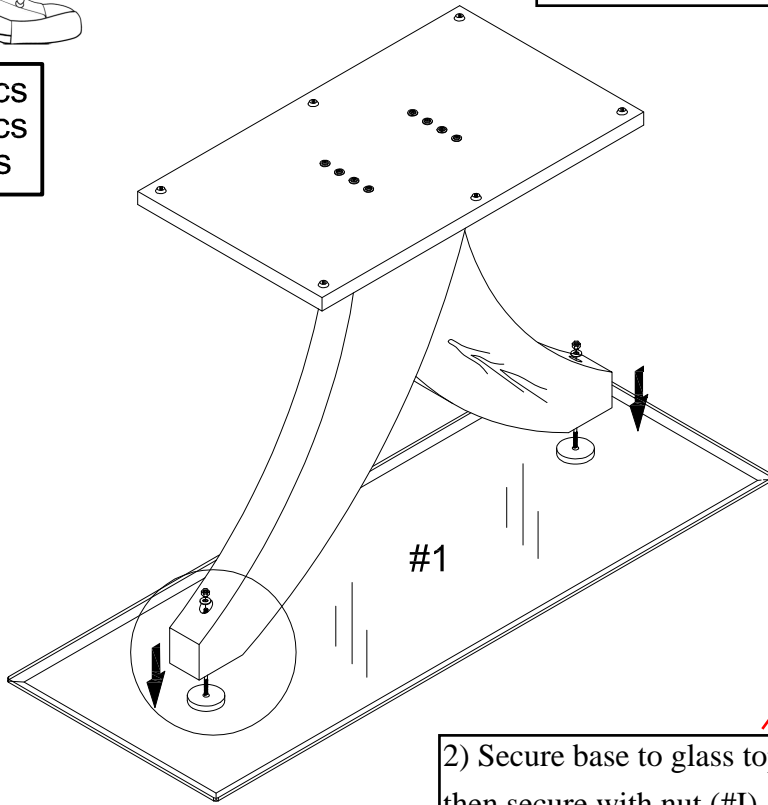

2) Secure base to glass top (#1). Insert washer (#H) to rod (#C), then secure with nut (#I).



#4

#J x 1pc  
#K x 1pc

Make sure bolts are secured tightly.

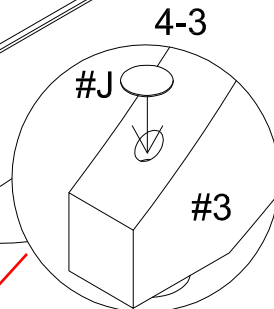
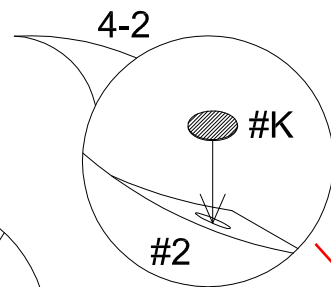
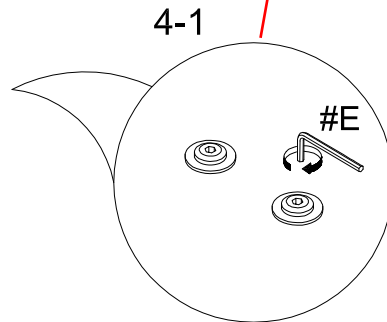
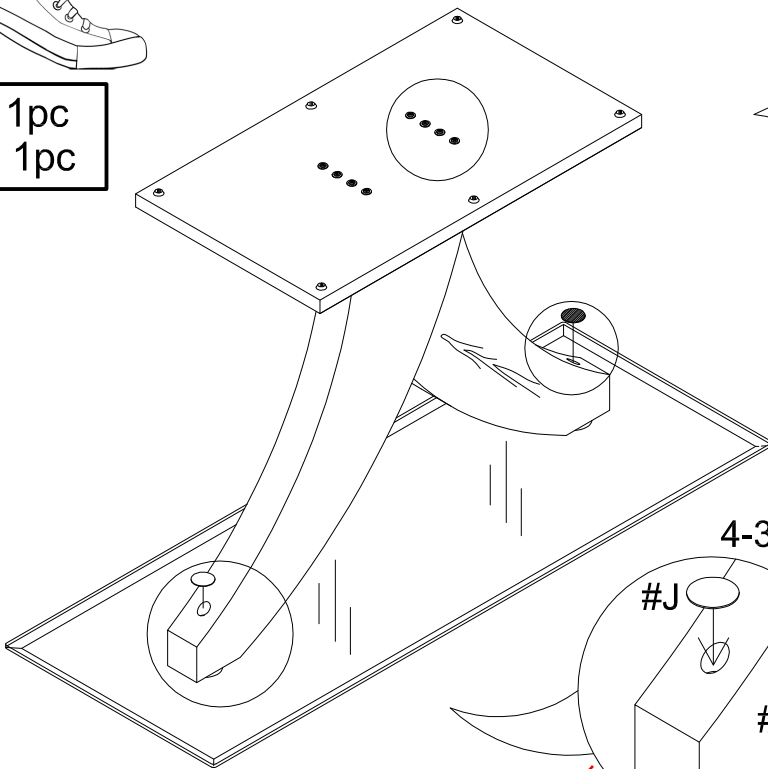

Place grey cover on the hole of bolt located at the right support leg (#2).

Place white cover on the hole of bolt located at the left support leg (#3).