

L-SHAPED DESK

ASSEMBLY INSTRUCTION

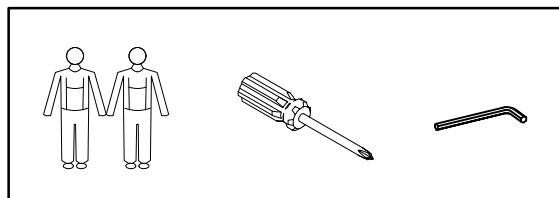
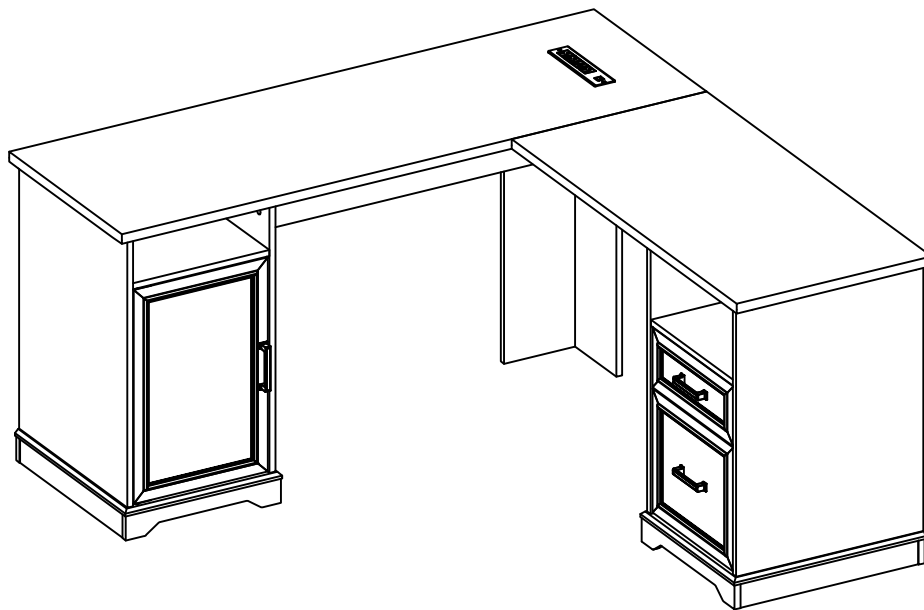

CAUTION

Put the screws in loosely until all pieces are together and then tighten them all.
It will save your time if you make a mistake while installing.



There are two packages for this desk, you may not receive them at the same time, please wait a few days if you only get one package.

Dear Customers,

Thank you for purchasing our products.

As a reliable seller, we have been pursuing to provide customers with 100% satisfied products and services, so we hope that you will enjoy this shopping experience.

If you find any damage, missing parts, or dissatisfaction after receiving the product, please contact us freely at the first time. We will provide you with a 100% satisfactory solution.

Thanks again for your order. Please feel free to contact us from Amazon or homeycs@hotmail.com in case of any problem regarding assembling or the product itself. We will do everything we can to resolve it. Please call for replacement parts or assistance: 1-857-800-8808. Mon-Fri 9am-5pm (PST)



Please follow the instruction manuals and use a pad to protect the product during your assembly.

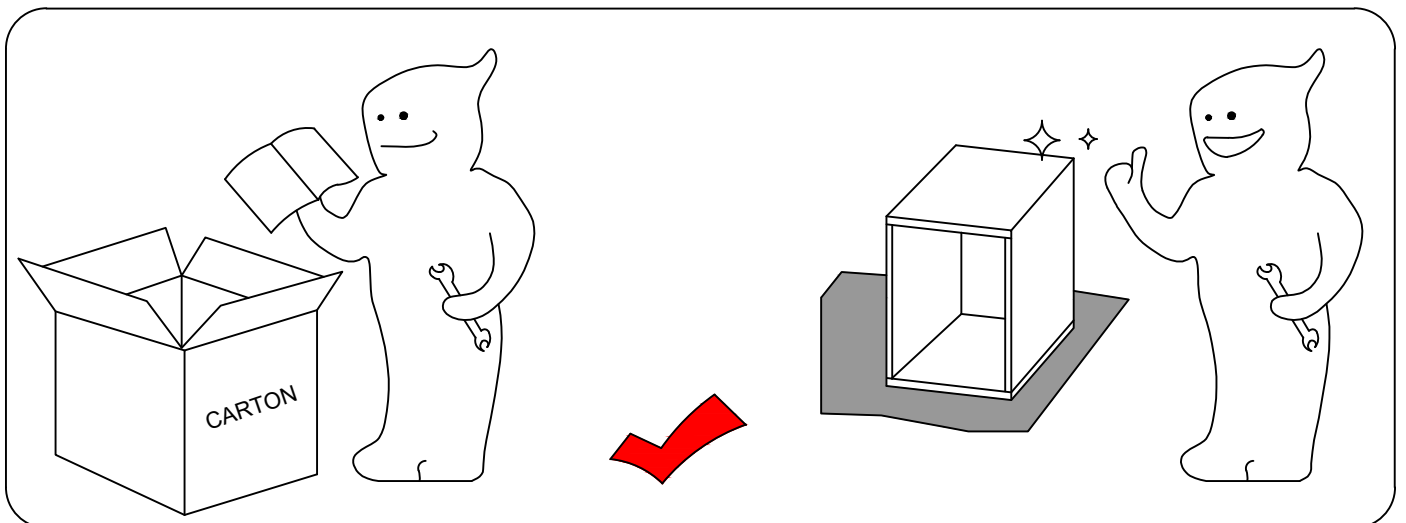
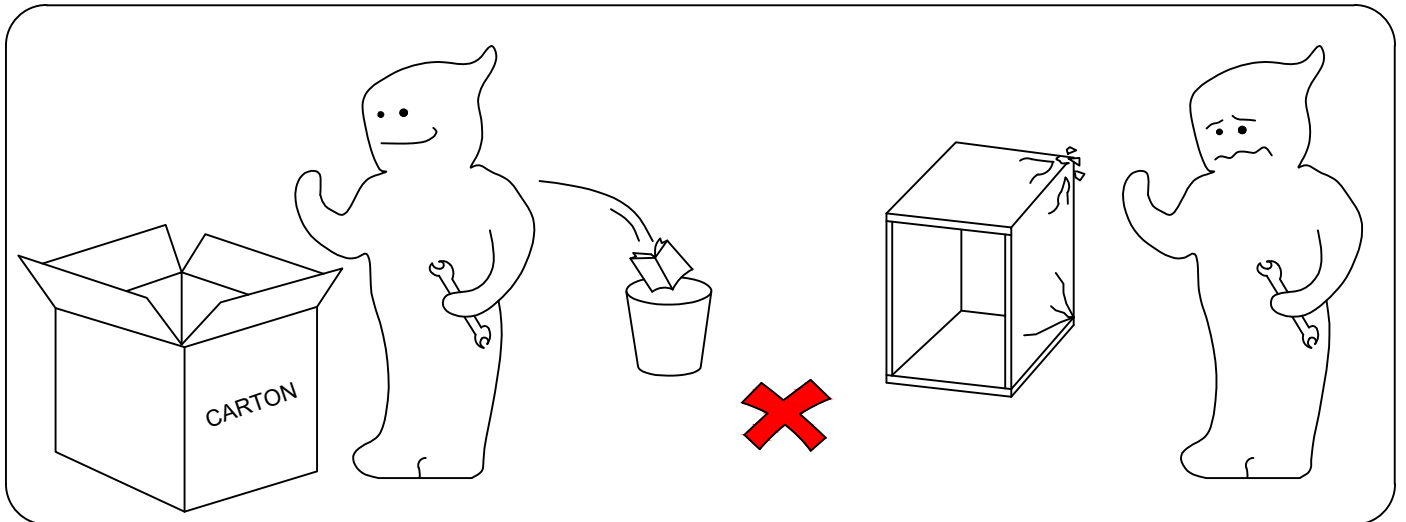

 homeycs@hotmail.com

Using Camlocks

Connect the male camlock as directed in the assembly instructions using a screwdriver.

1 DO NOT OVER TIGHTEN

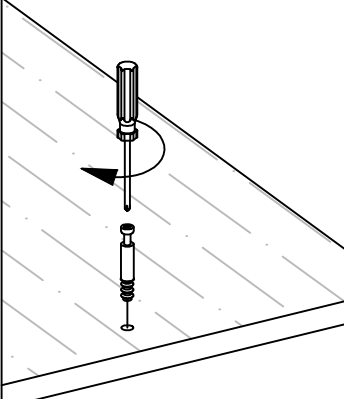

Push the male camlock into the entry hole.

2

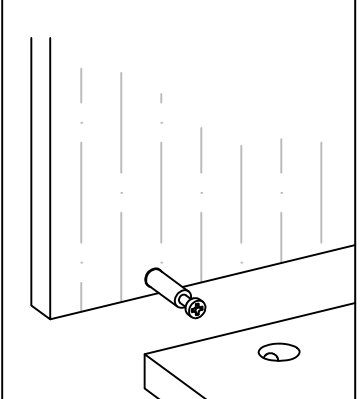

Insert the female camlock as shown in the instruction.

Note: ensure that the arrow on the top of the camlock points toward the entry hole for the male camlock.

3

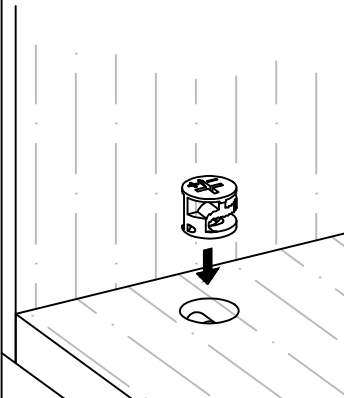

Turn the female camlock clockwise with a screwdriver.

You should feel a click when the camlock is locked in place.





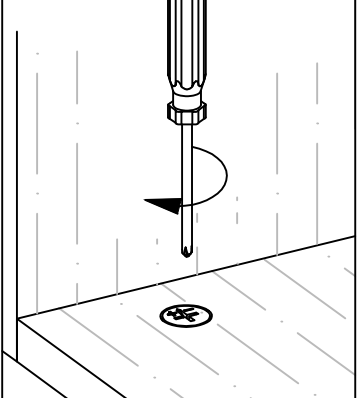

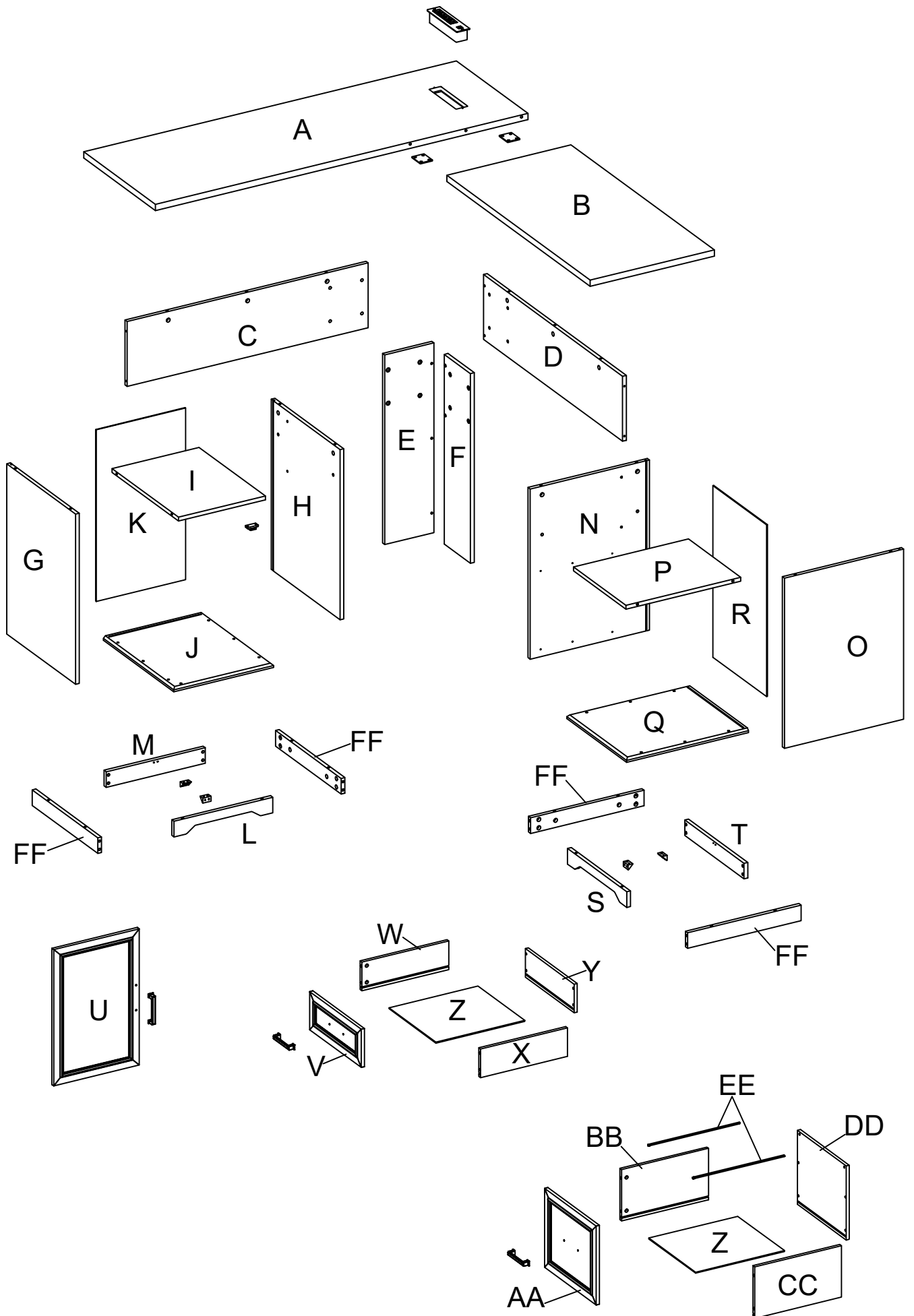
The joint is now secure.

4

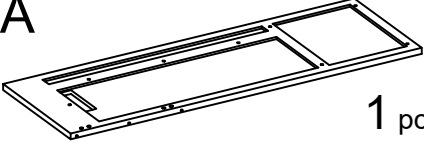
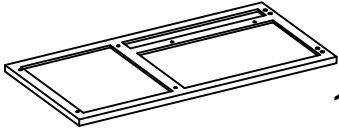
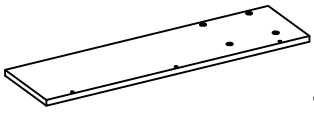
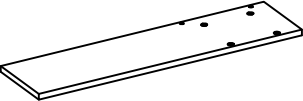
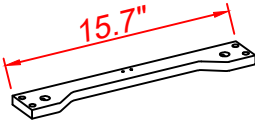
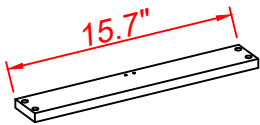
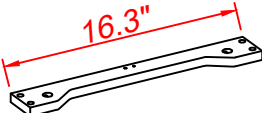
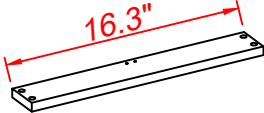
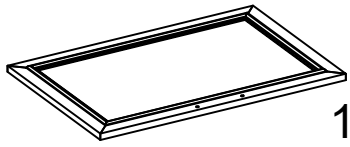

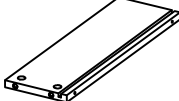
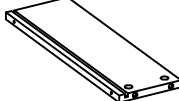

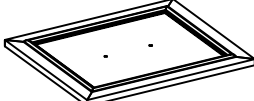
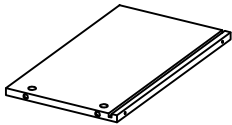
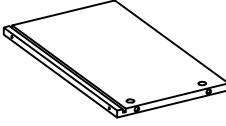
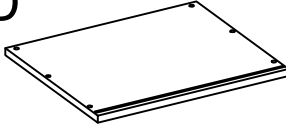





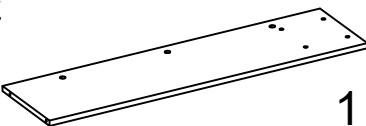
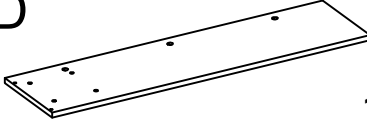
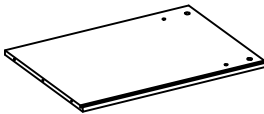
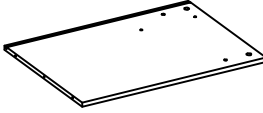
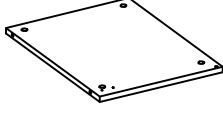
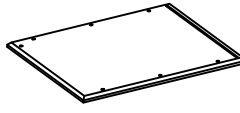
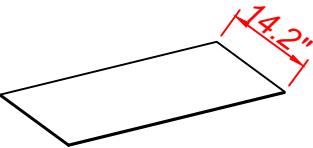
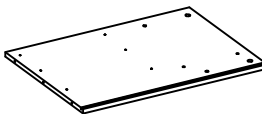
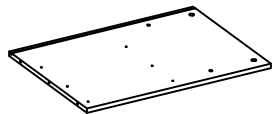
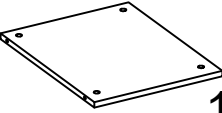
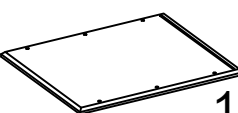
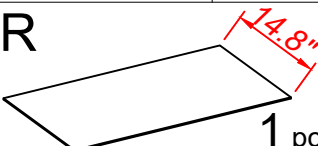
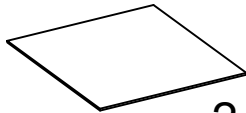



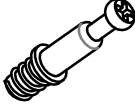

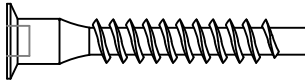
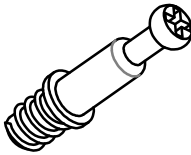

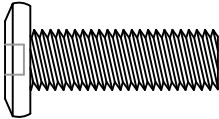
PART LIST A

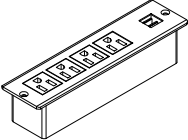
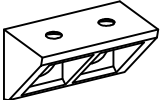
<p>A</p>  <p>1 pc</p>	<p>B</p>  <p>1 pc</p>	<p>E</p>  <p>1 pc</p>
<p>F</p>  <p>1 pc</p>	<p>L</p>  <p>1 pc</p>	<p>M</p>  <p>1 pc</p>
<p>S</p>  <p>1 pc</p>	<p>T</p>  <p>1 pc</p>	<p>U</p>  <p>1 pc</p>
<p>V</p>  <p>1 pc</p>	<p>W</p>  <p>1 pc</p>	<p>X</p>  <p>1 pc</p>
<p>Y</p>  <p>1 pc</p>	<p>AA</p>  <p>1 pc</p>	<p>BB</p>  <p>1 pc</p>
<p>CC</p>  <p>1 pc</p>	<p>DD</p>  <p>1 pc</p>	<p>EE</p>  <p>368L 2 pcs</p>
<p>FF</p>  <p>4 pcs</p>		

PART LIST B

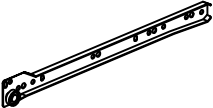
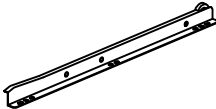
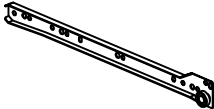
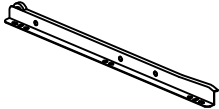
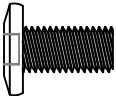
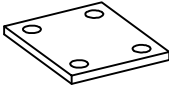
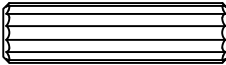
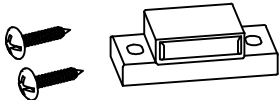
<p>C</p>  <p>1 pc</p>	<p>D</p>  <p>1 pc</p>	<p>G</p>  <p>1 pc</p>	
<p>H</p>  <p>1 pc</p>	<p>I</p>  <p>1 pc</p>	<p>J</p>  <p>1 pc</p>	
<p>K</p>  <p>1 pc</p>	<p>N</p>  <p>1 pc</p>	<p>O</p>  <p>1 pc</p>	
<p>P</p>  <p>1 pc</p>	<p>Q</p>  <p>1 pc</p>	<p>R</p>  <p>1 pc</p>	<p>Z</p>  <p>2 pcs</p>

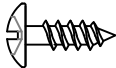
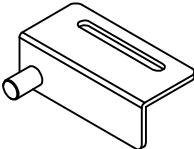
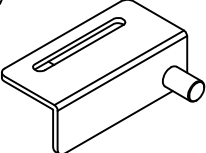
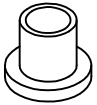
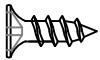
HARDWARE LIST

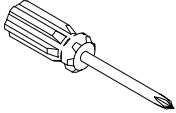
①  M6x28 8 pcs	②  Ø12 8 pcs	③  M6x40 29 pcs	④  M6x40 50 pcs
⑤  Ø15 50 pcs	⑥  M8x25 8 pcs	⑦  M3x12 28 pcs	⑧  1 pc
⑨  4 pcs	⑩  M4x8 4 pcs	⑪  M4x16 2 pcs	⑫  3 pcs
⑬  350L 2 pcs	⑭  350L 2 pcs	⑮  350L 2 pcs	⑯  350L 2 pcs
⑰  M6x12 8 pcs	⑱  60*50*3 2 pcs	⑲  Ø8x30 3 pcs	⑳  M3x16 1 pc
㉑  1 pc	㉒  M3.5x12 4 pcs	㉓  1 pc	㉔  1 pc
㉕  2 pcs	㉖  M4x12 16 pcs	㉗  M4 1 pc	㉘  1 pc

STEP 1

③  x4

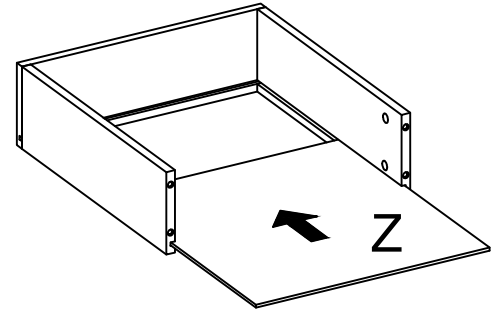
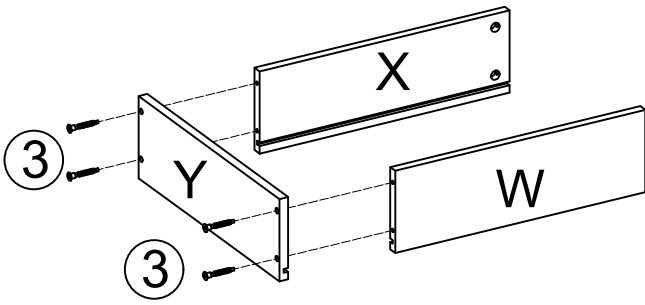

STEP 2

①  x4

②  x4

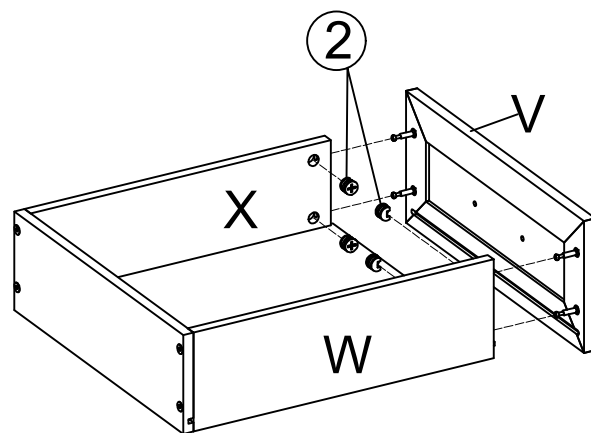
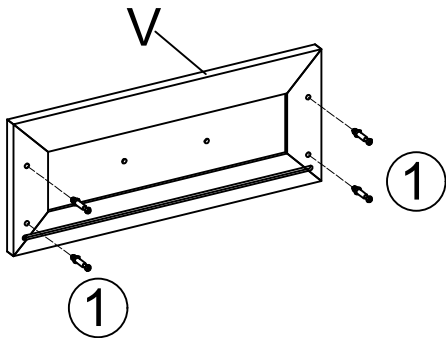

STEP 3

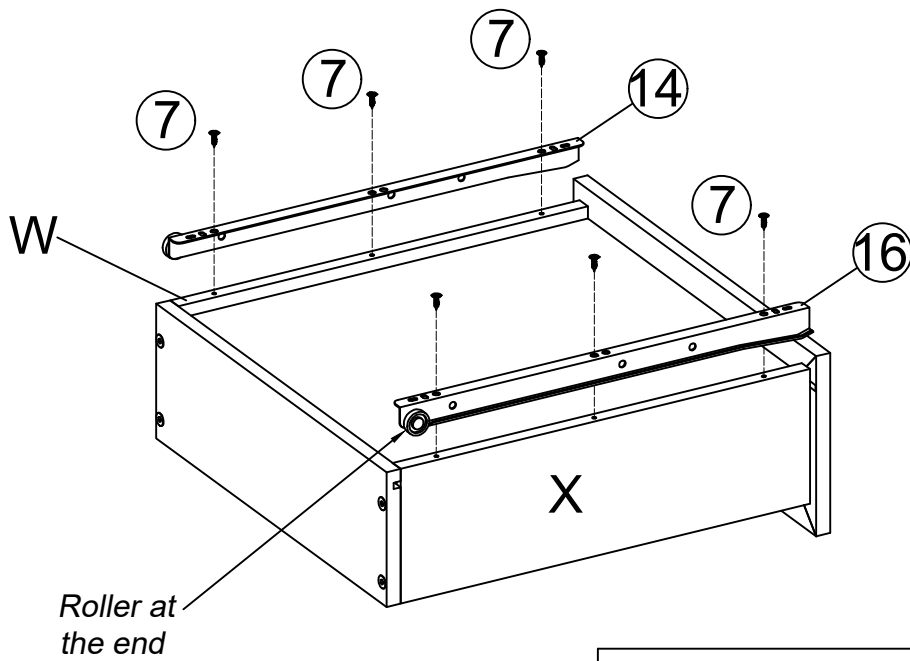

7 x6

14 x1

16 x1

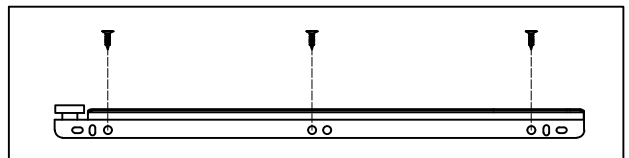

STEP 4

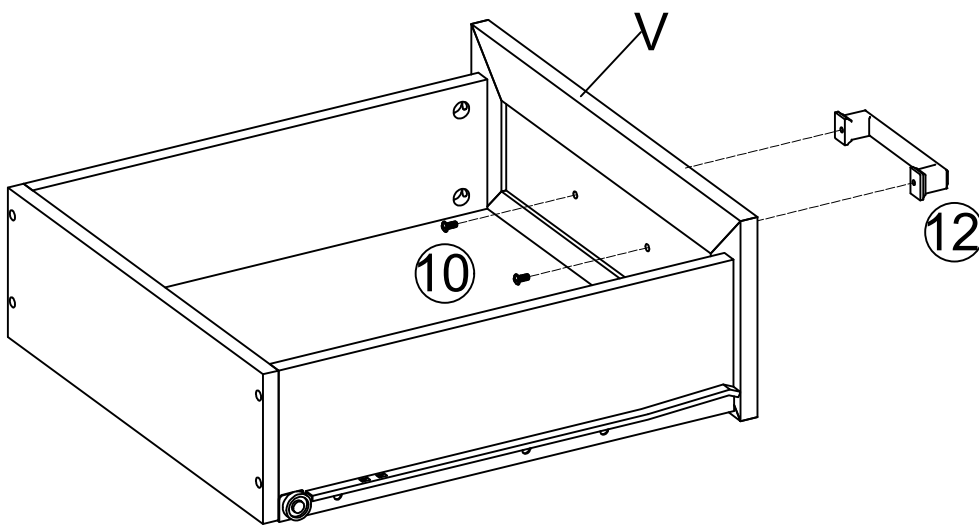

10 x2

12 x1

STEP 5

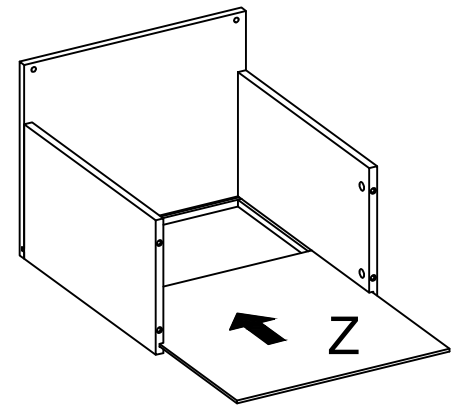
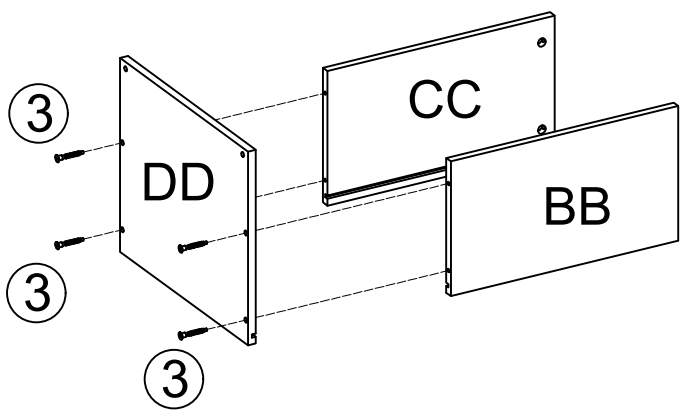
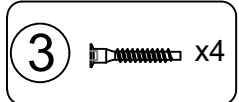

STEP 6

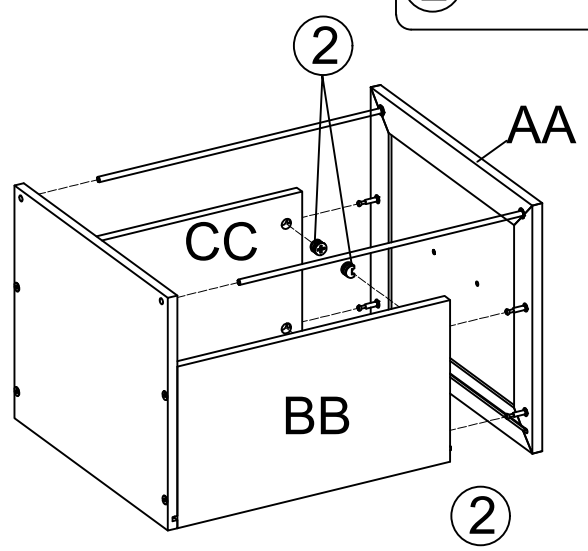
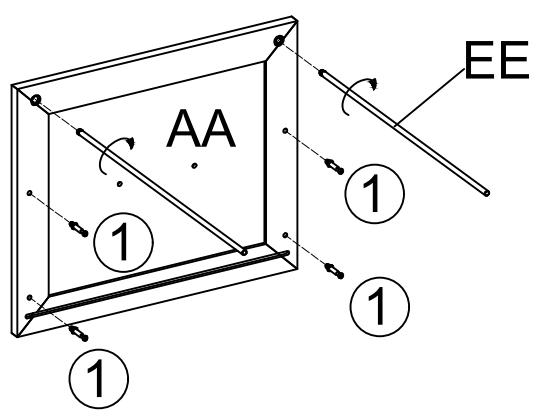
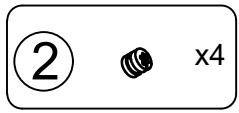
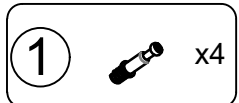

STEP 7

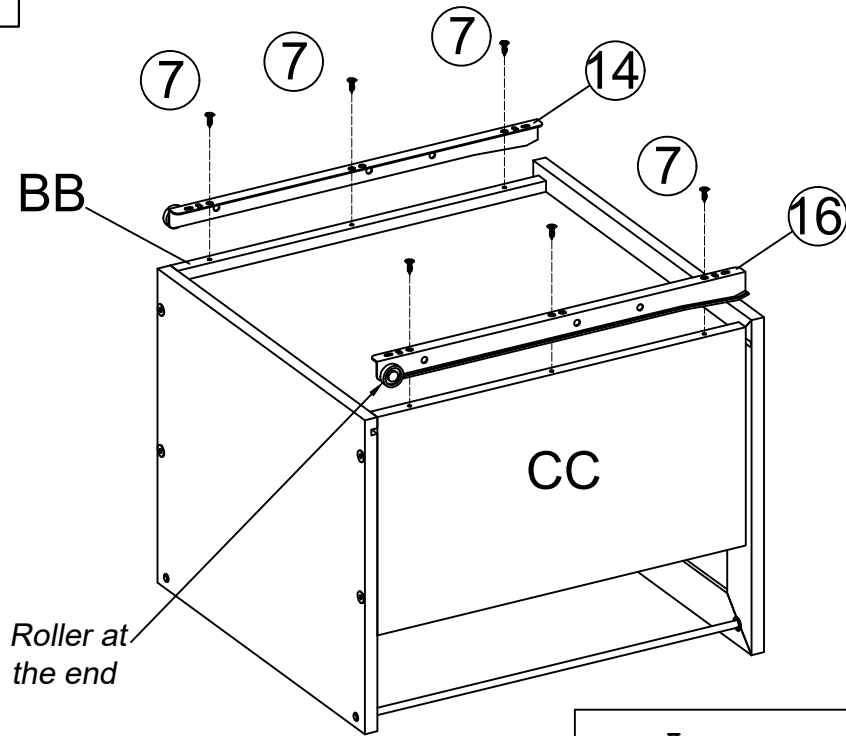

- 7 x6
- 14 x1
- 16 x1

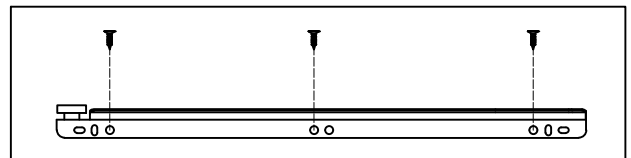

STEP 8

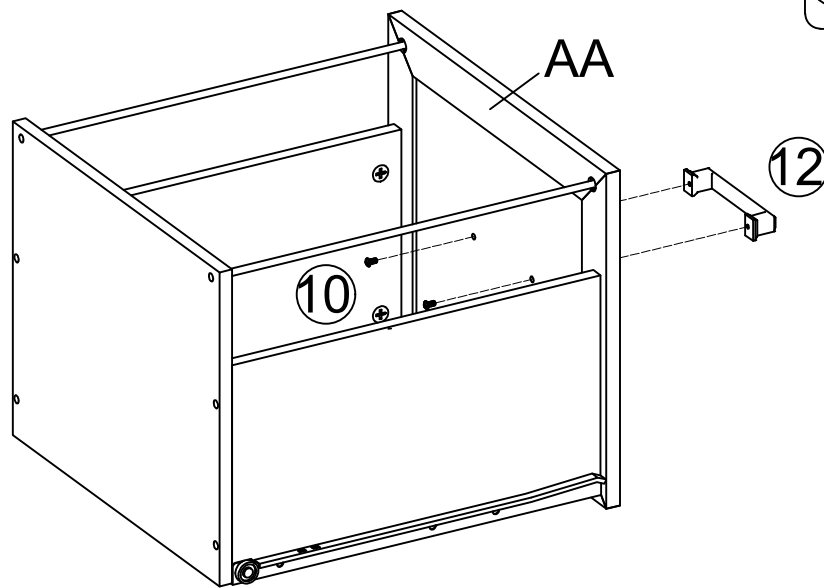

- 10 x2
- 12 x1

STEP 9

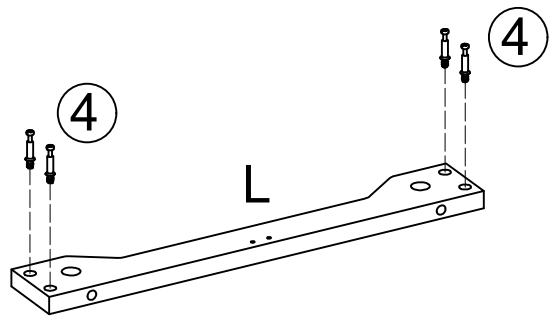
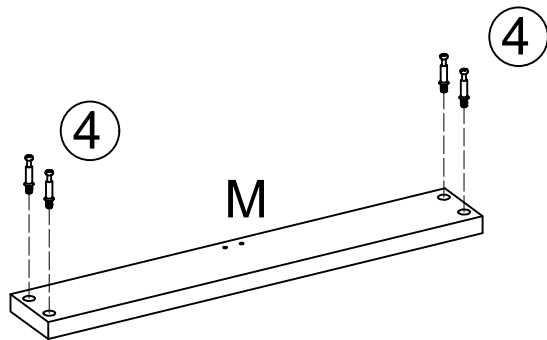
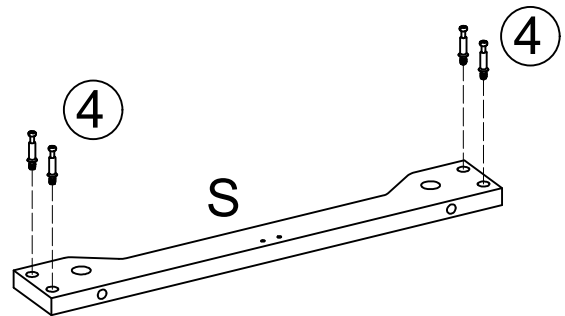
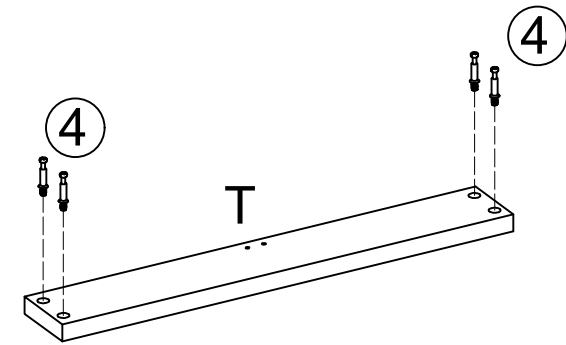

STEP 10



Keep the holes of the Part T, Part M and Part FF toward this direction as shown

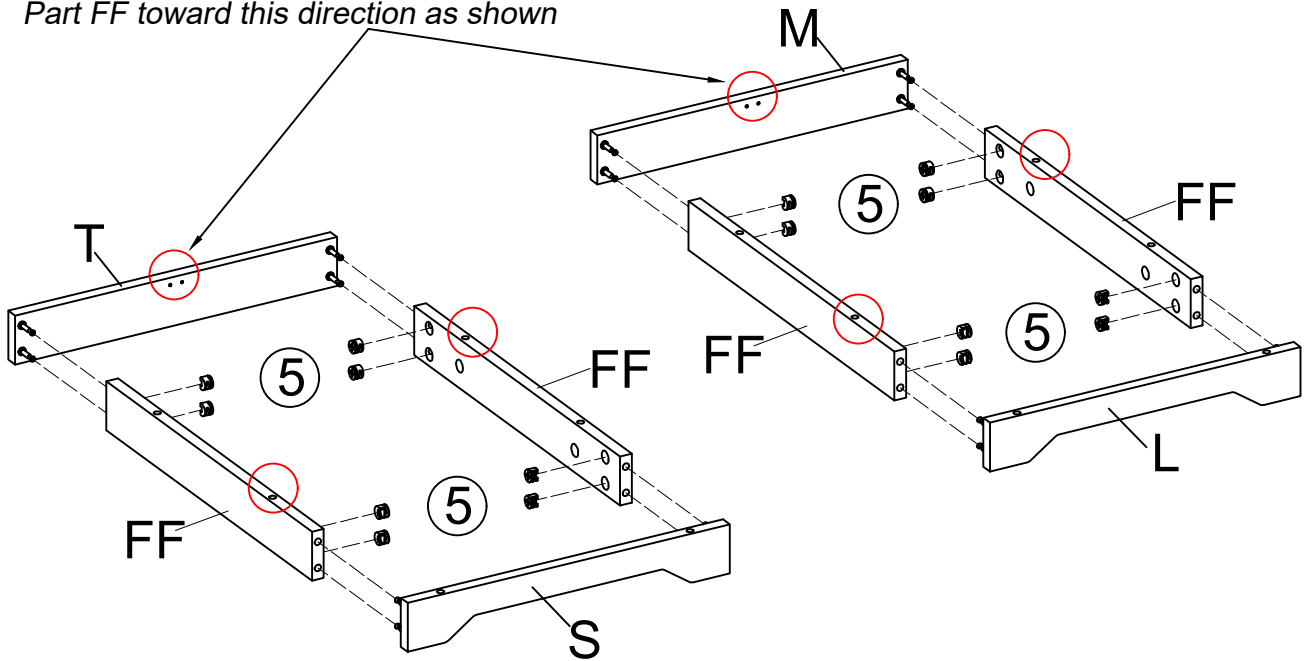

STEP 11

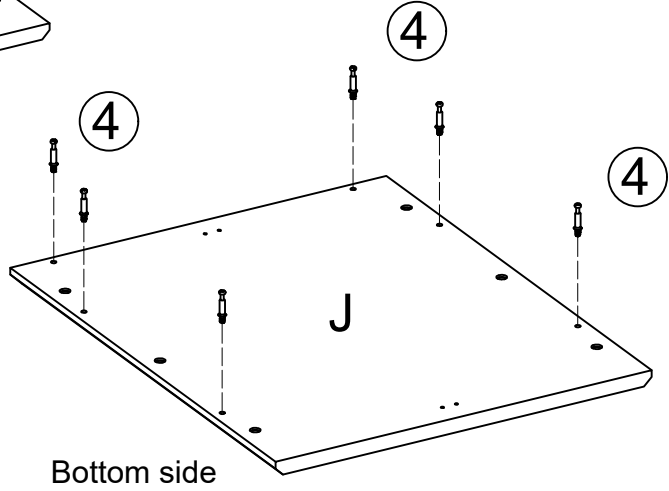
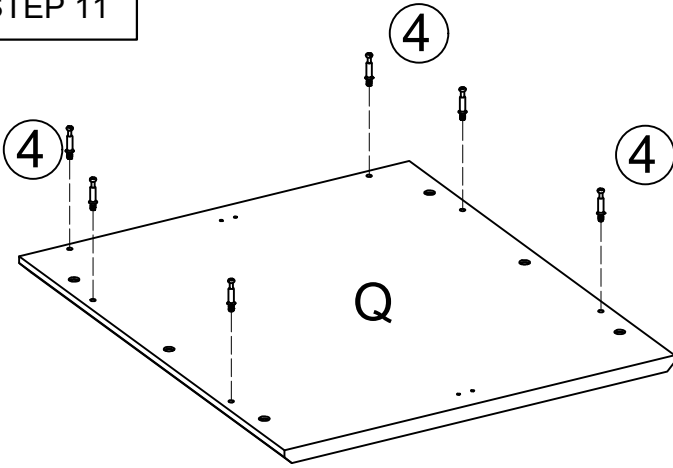
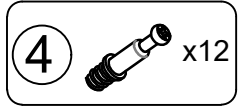

Top side

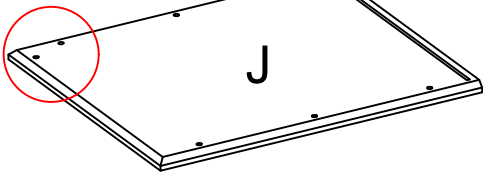

Bottom side

STEP 12

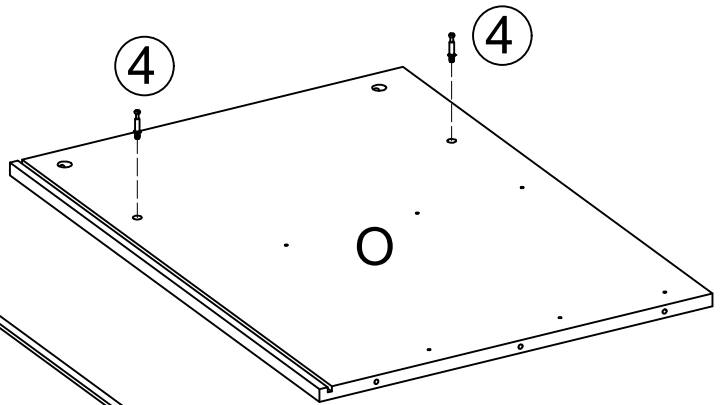
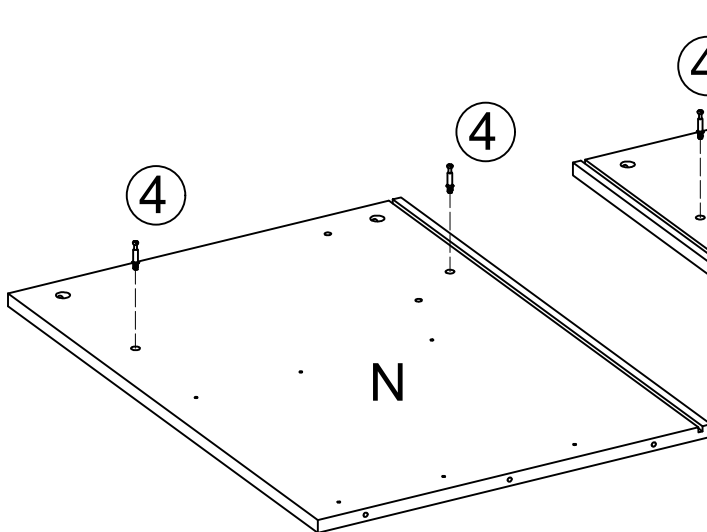
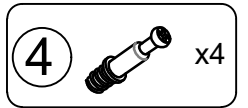

STEP 13

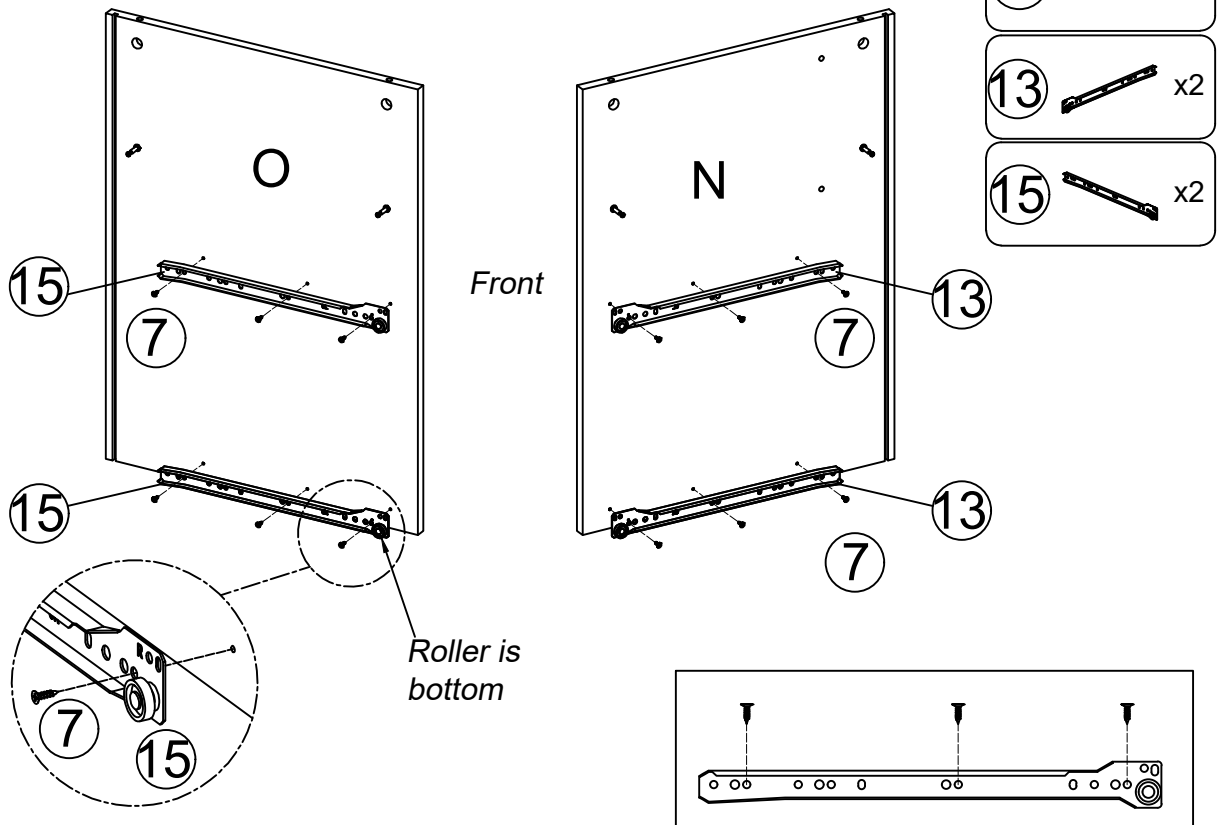

STEP 14

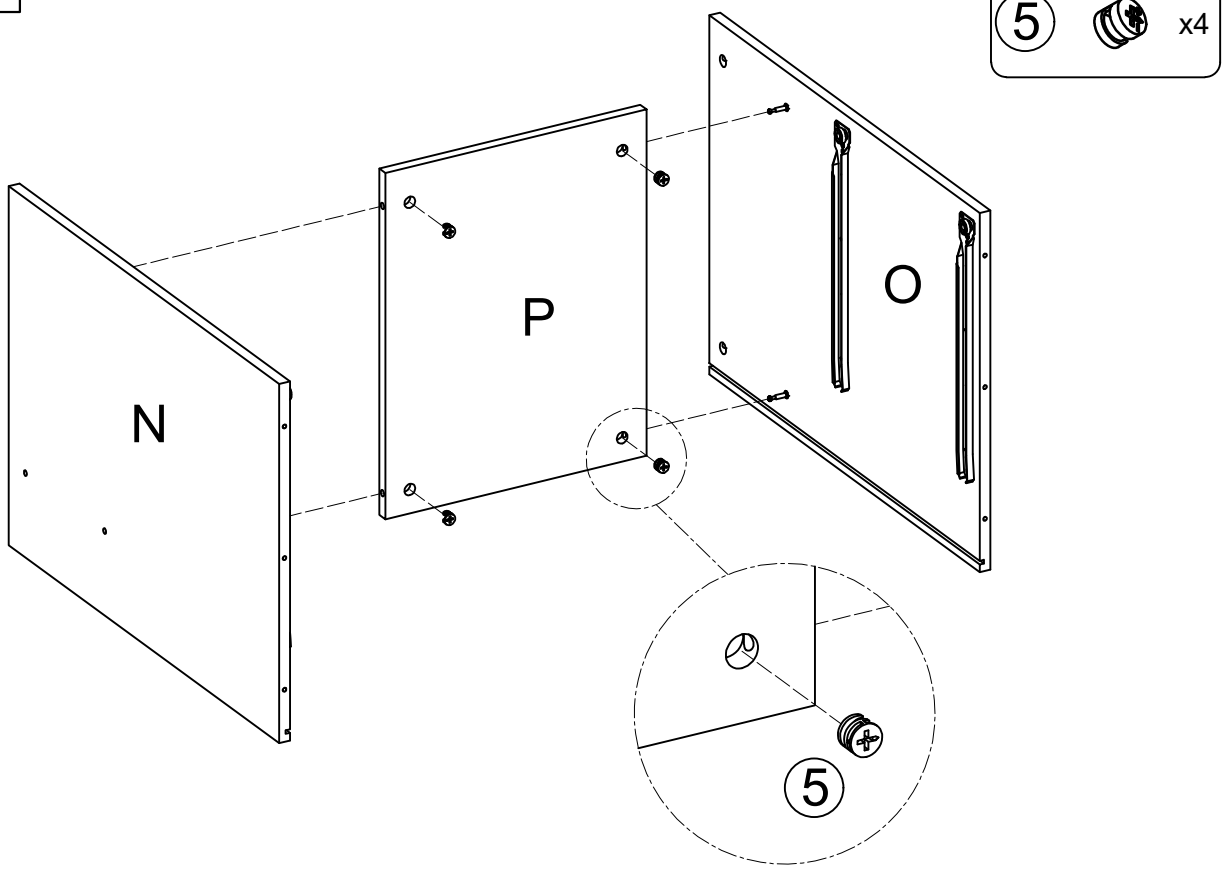

STEP 15

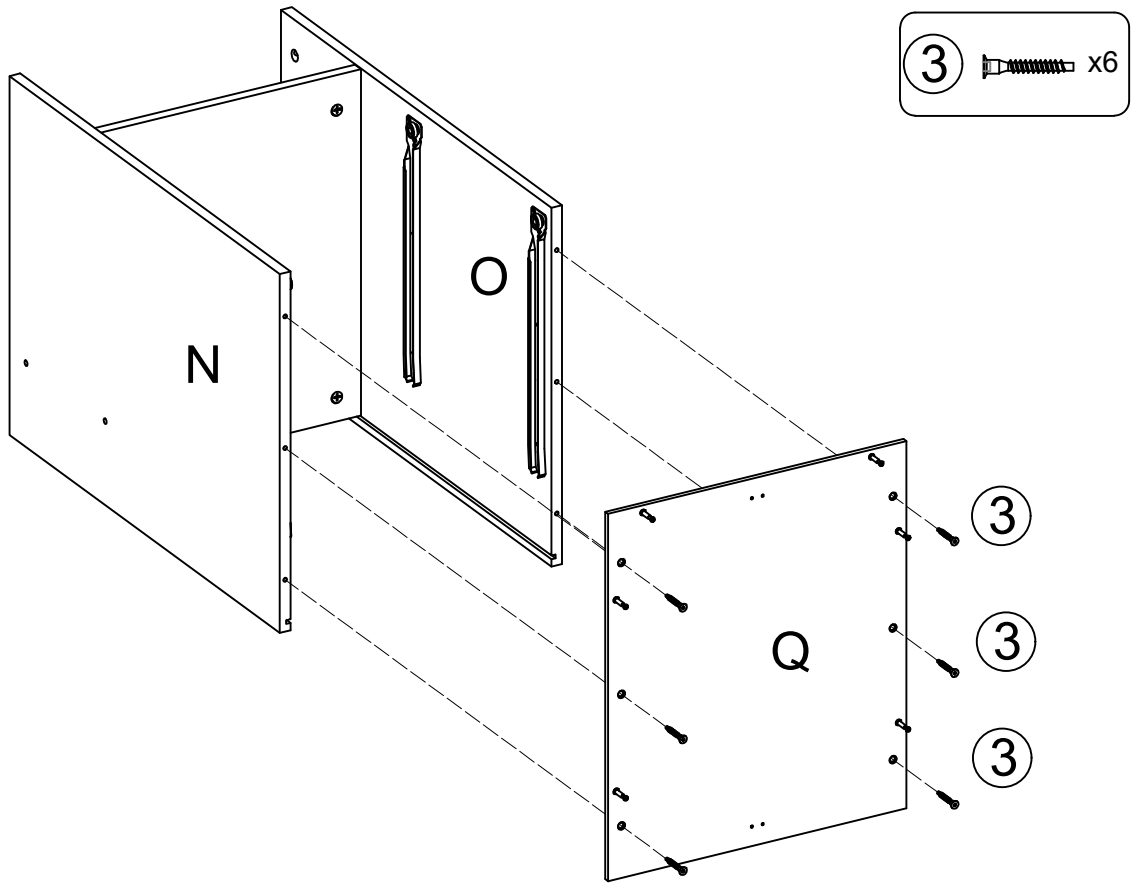

STEP 16

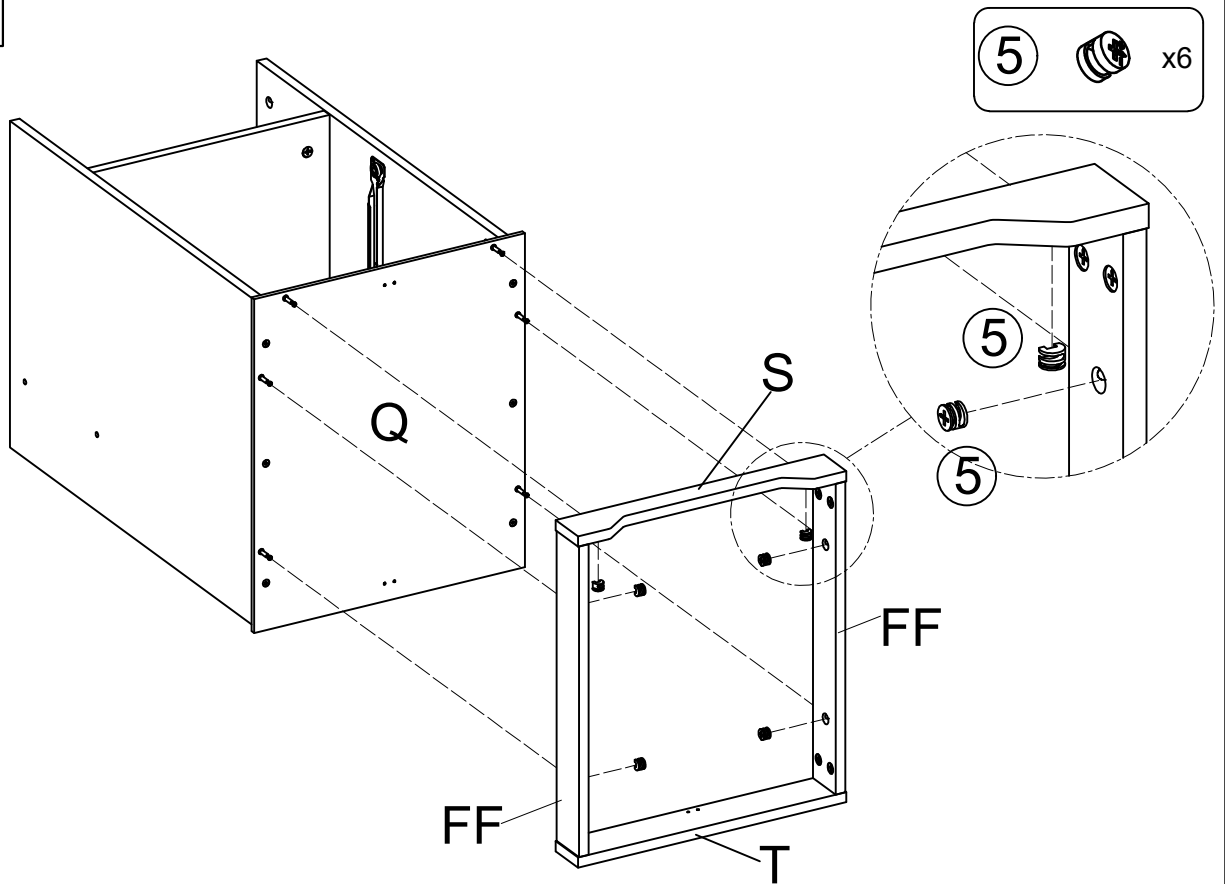

STEP 17

9  x2

26  x8

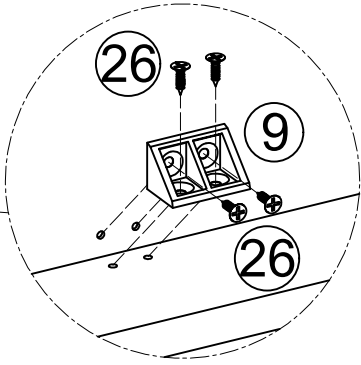
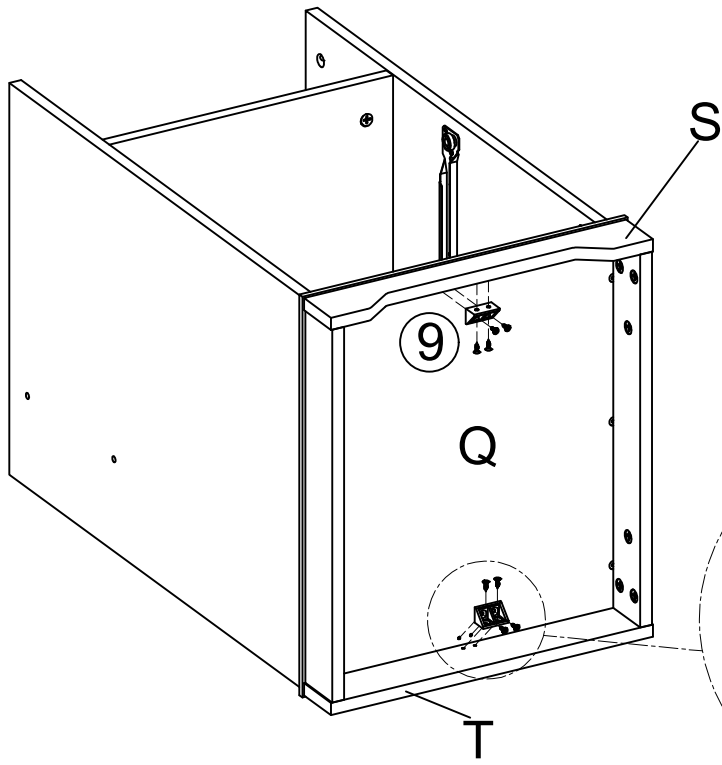

STEP 18

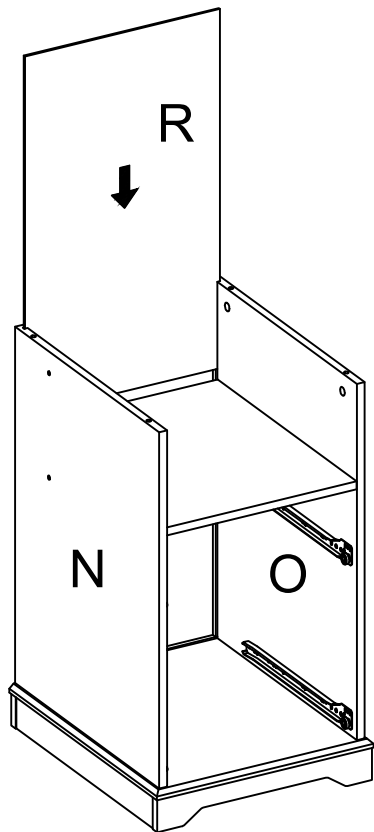

STEP 19

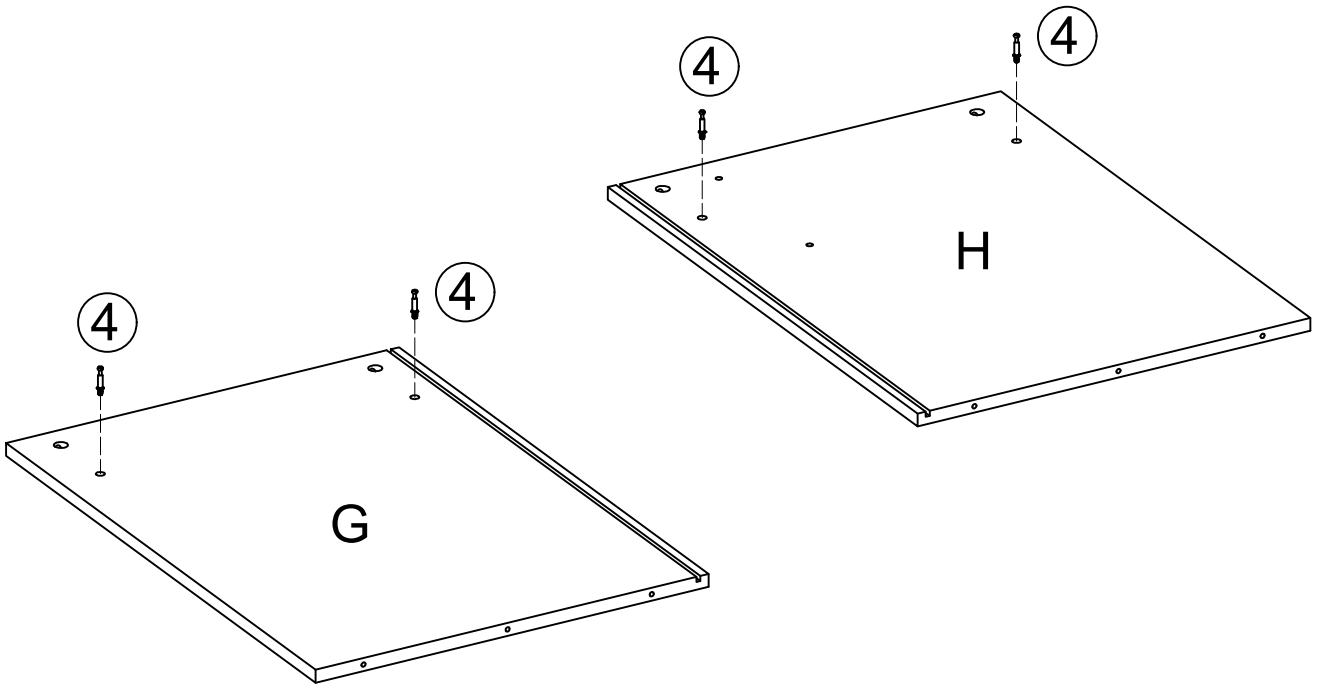

STEP 20

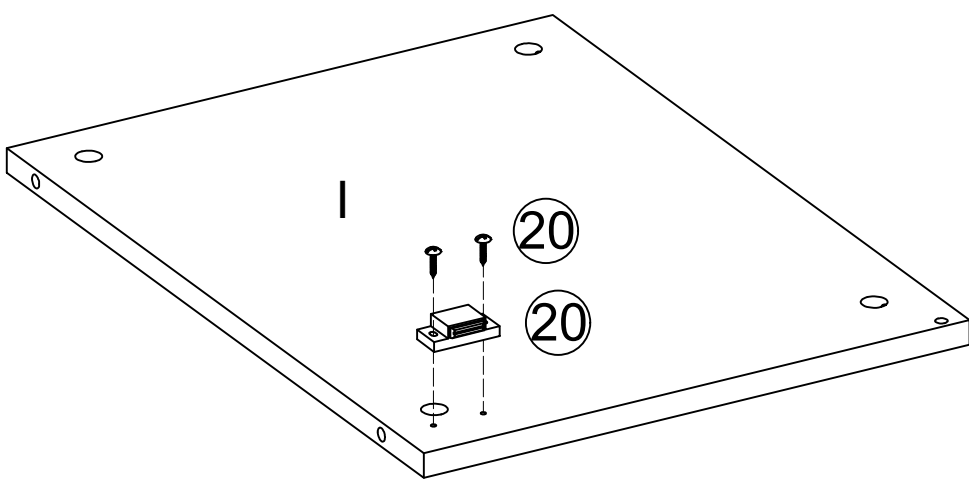
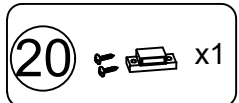

STEP 21

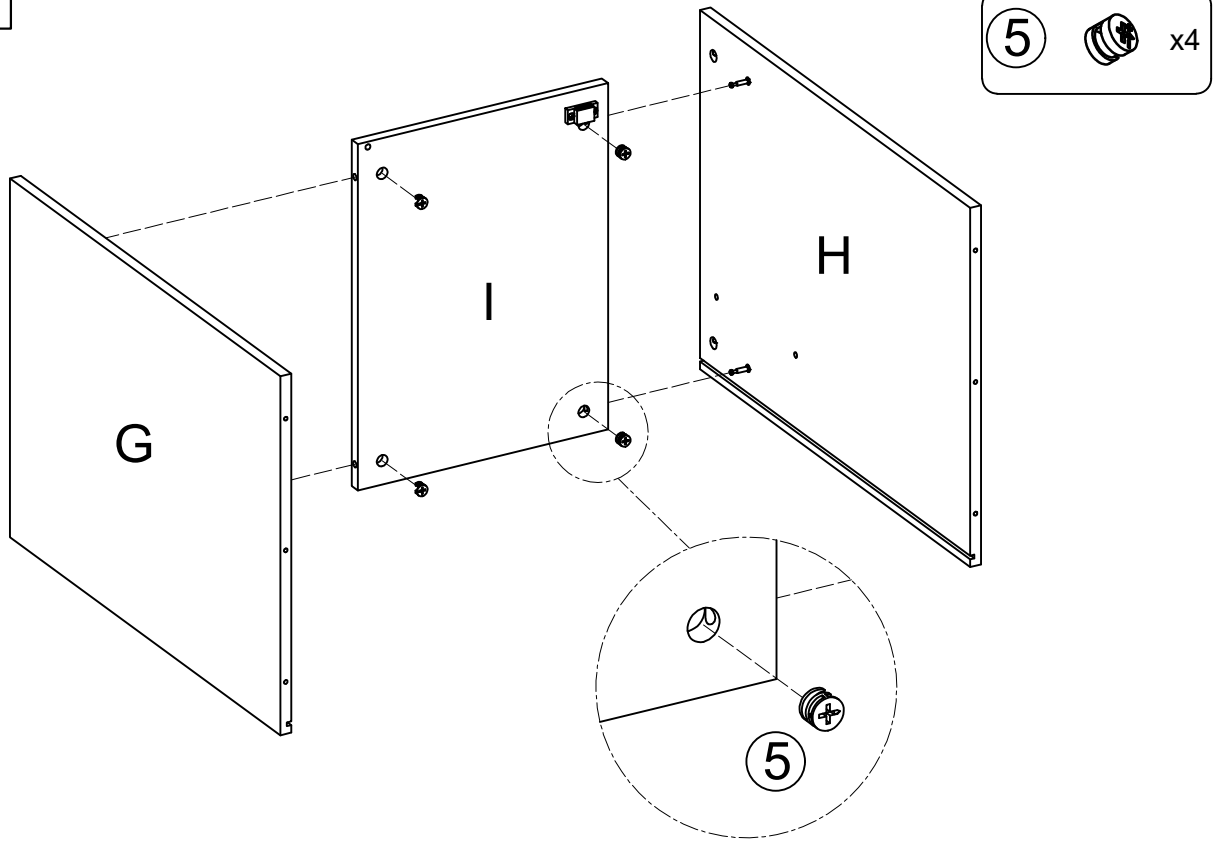

STEP 22

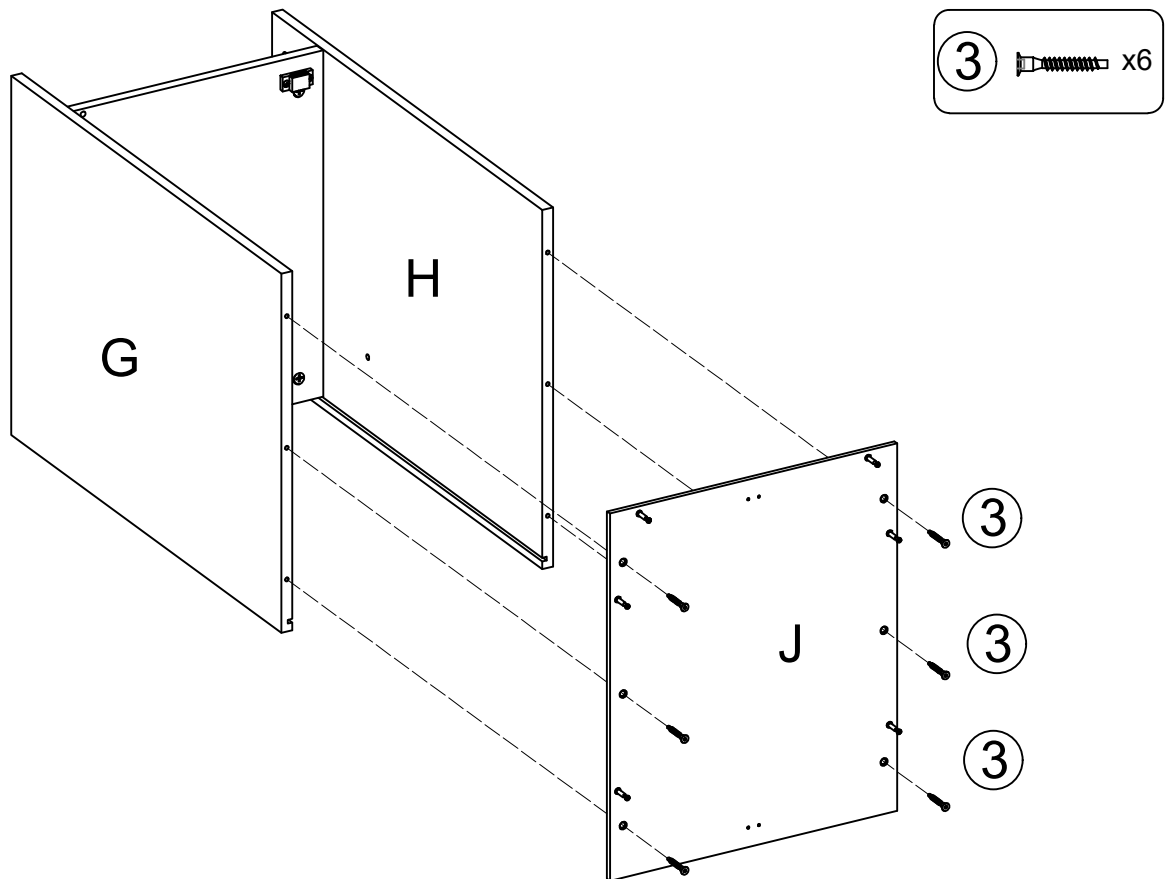

STEP 23

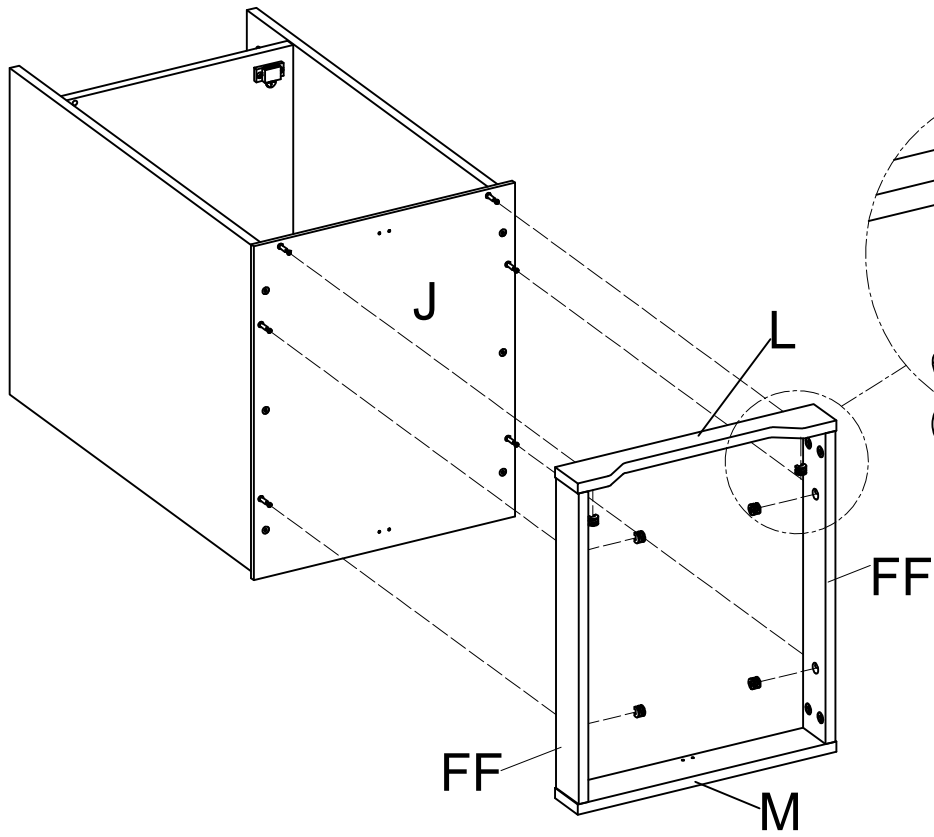

5 x6

STEP 24

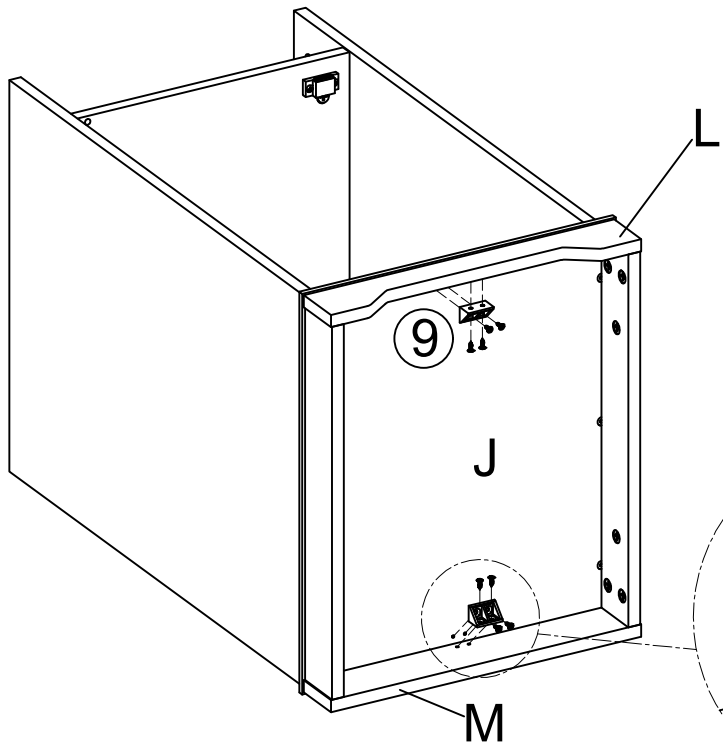

9 x2

26 x8

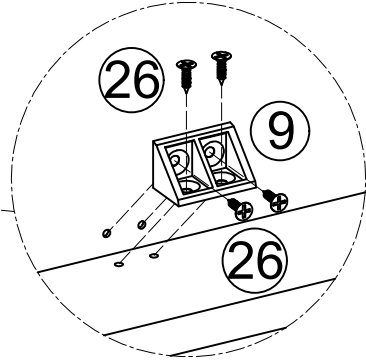

STEP 25

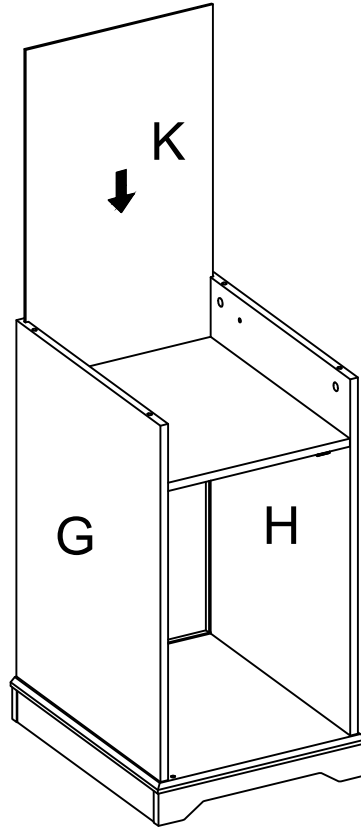

STEP 26

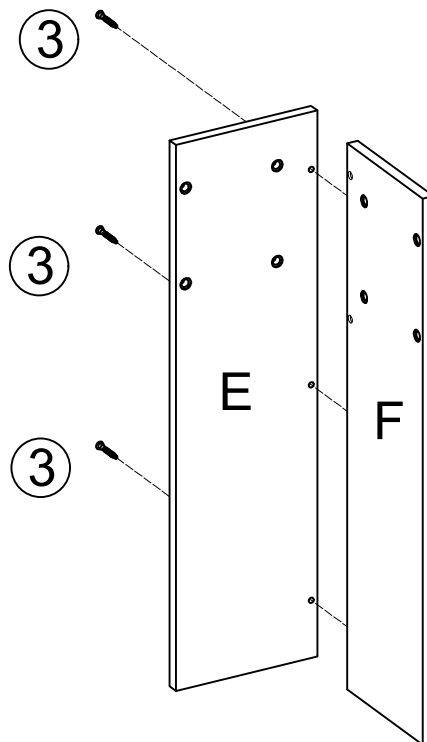
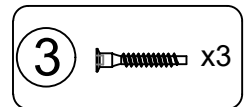

STEP 27

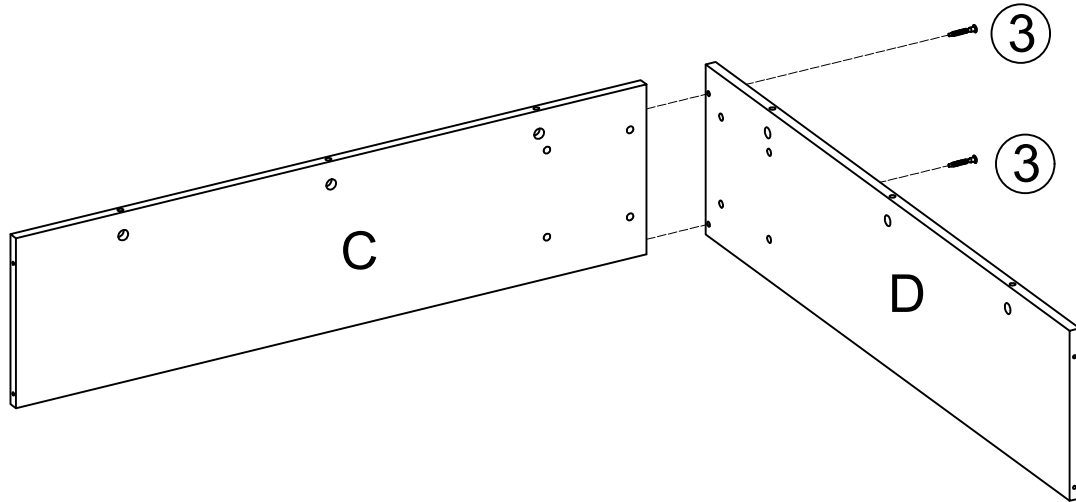

STEP 28

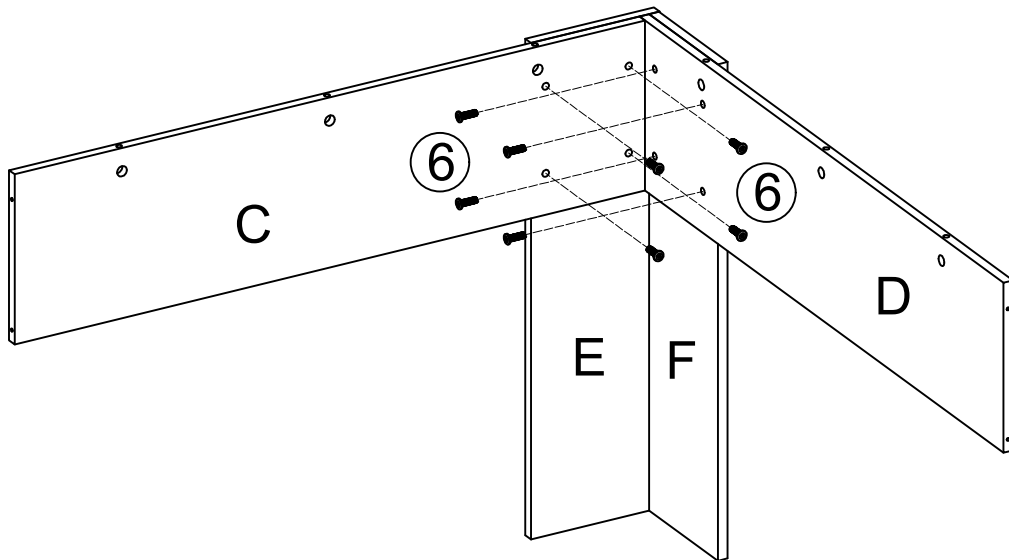
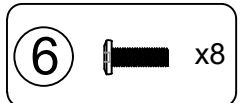

STEP 29

3  x4

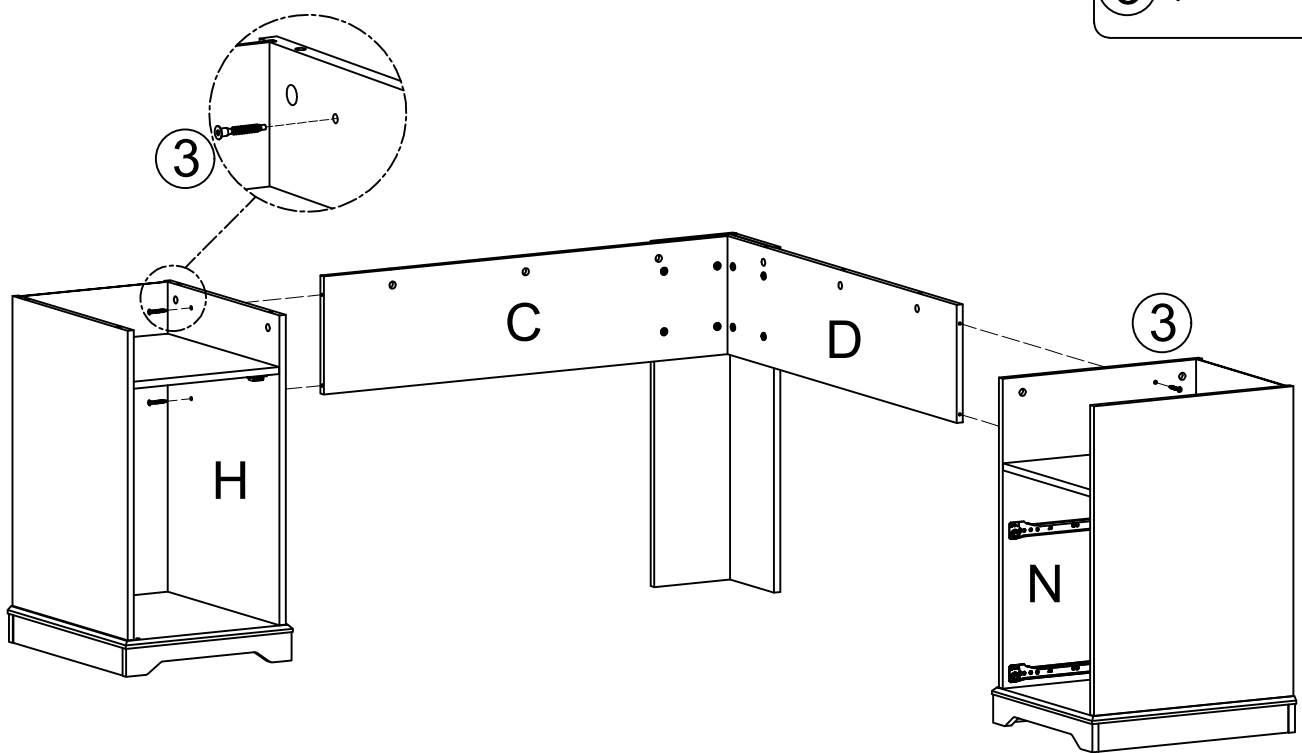

STEP 30

4  x14

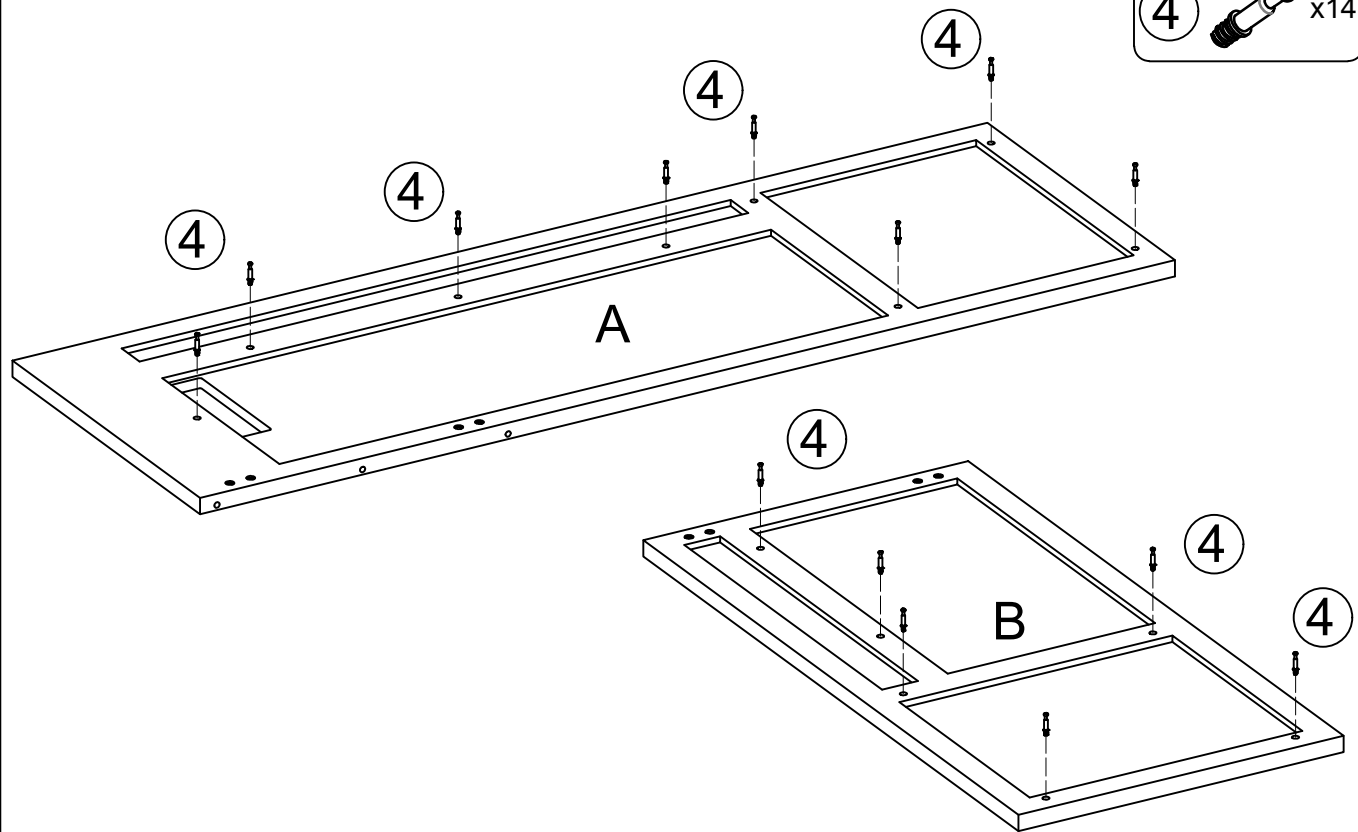

STEP 31

19  x3

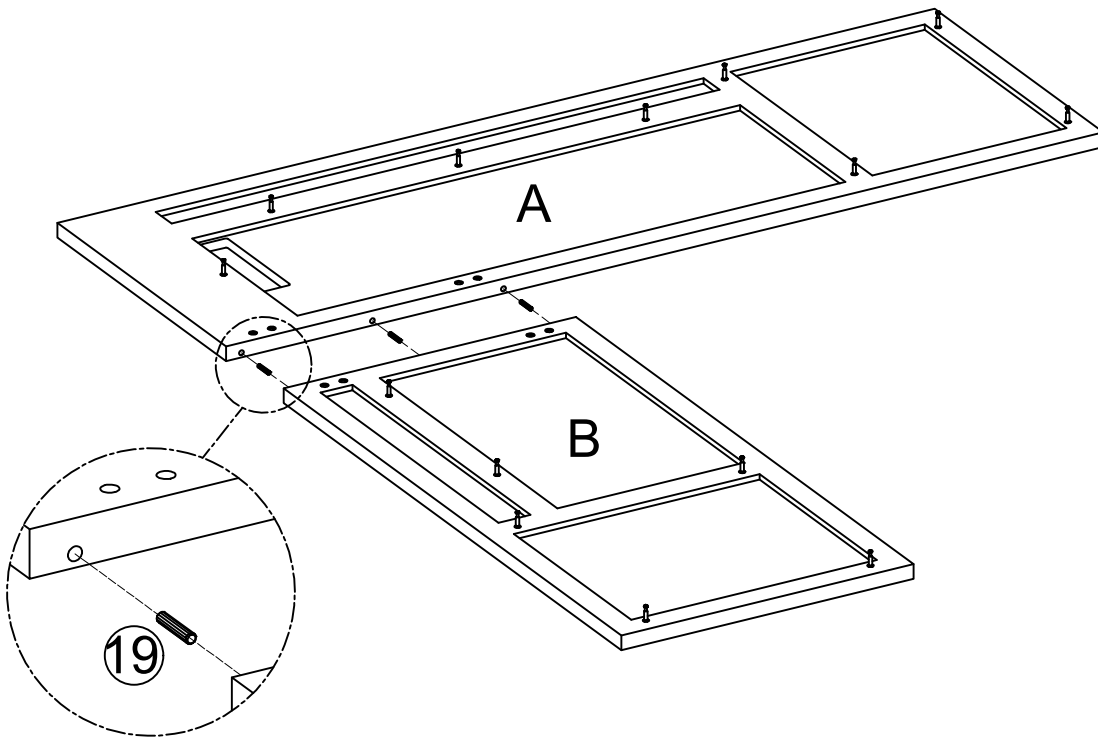

STEP 32

Note: Before tightening the screws, push the wood boards tightly to make closer, otherwise it may cause large gaps.

17  x8

18  x2

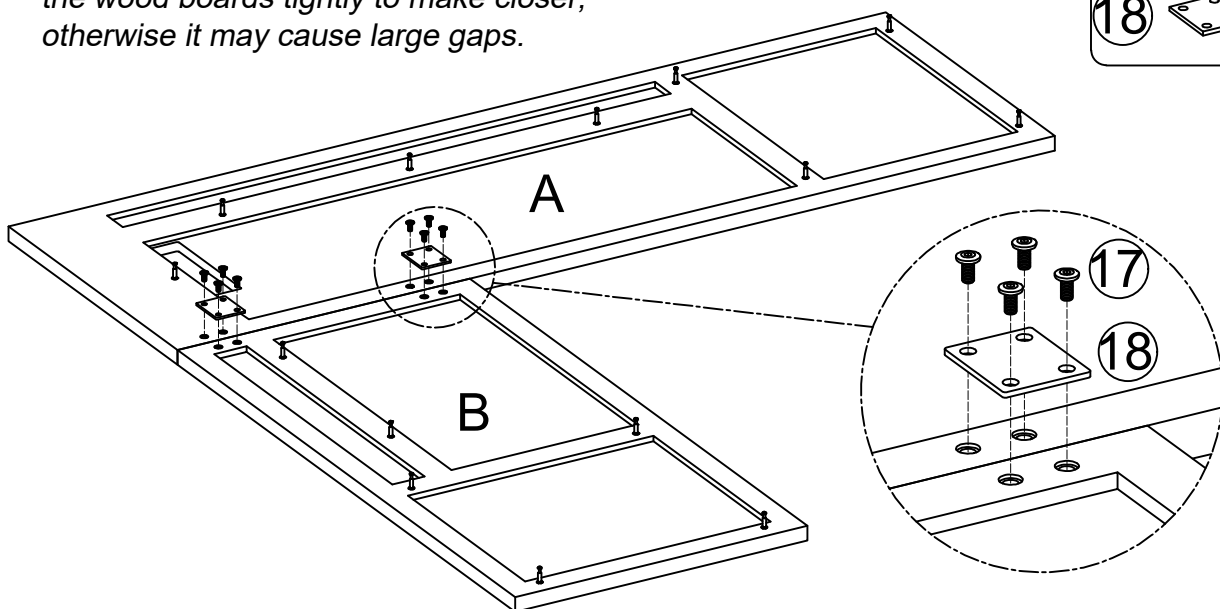



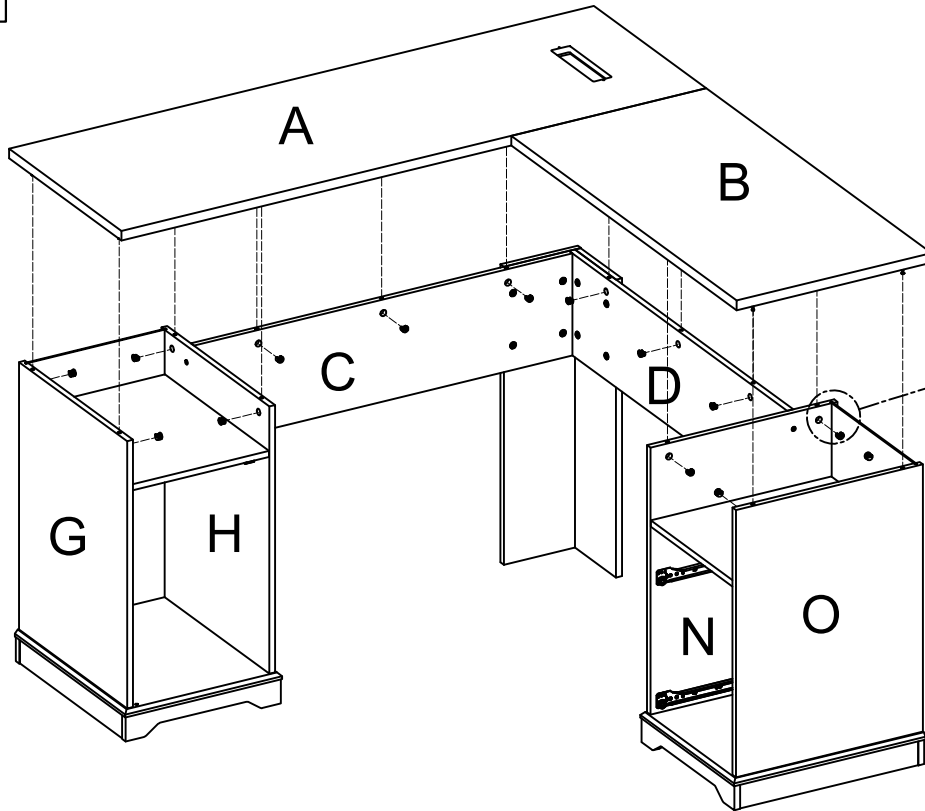



STEP 33

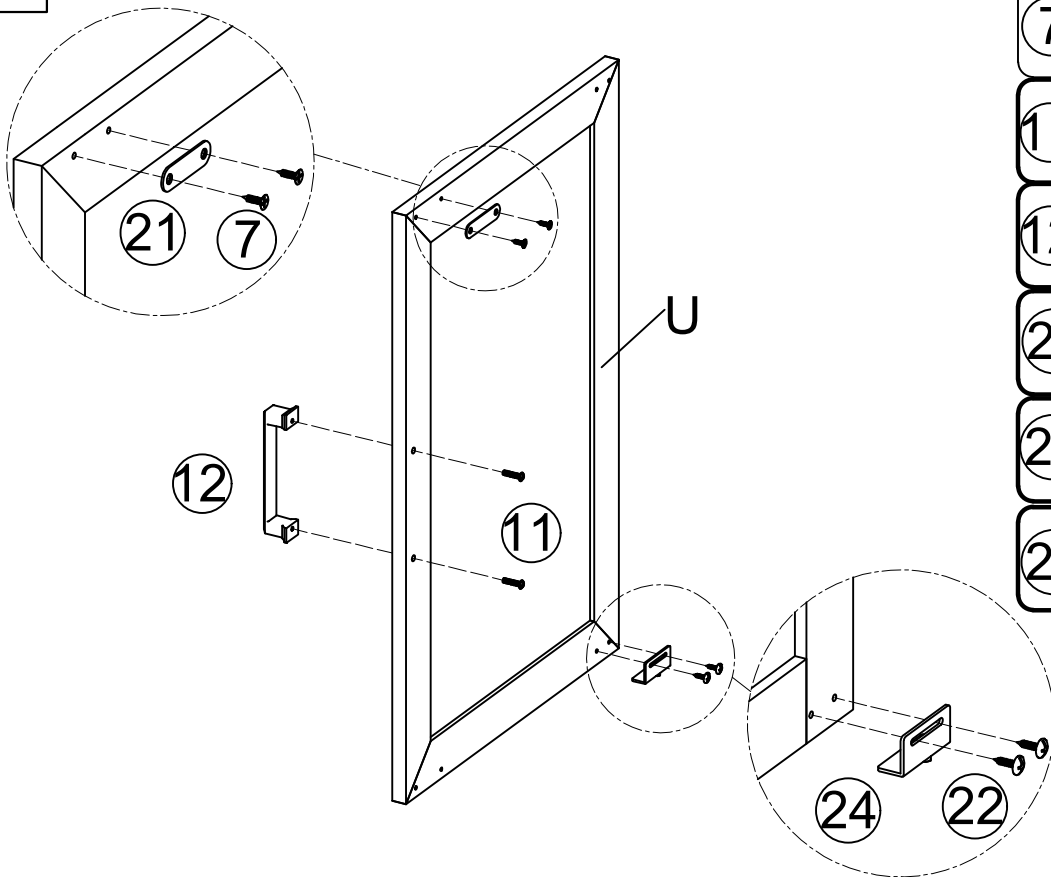

- 5  x14

STEP 34





- 7  x2
- 11  x2
- 12  x1
- 21  x1
- 22  x2
- 24  x1

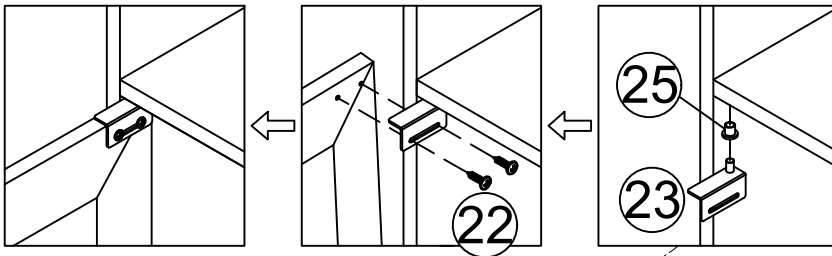

STEP 35



Step 2

- 22  x2
- 23  x1
- 25  x2

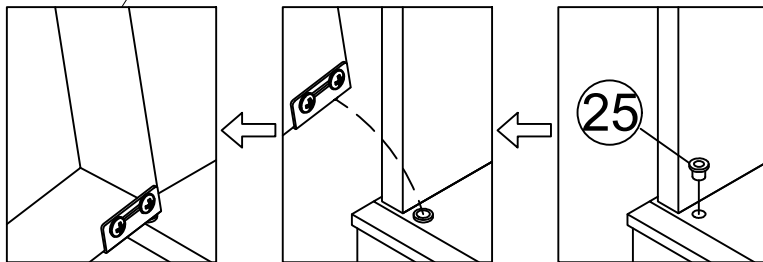
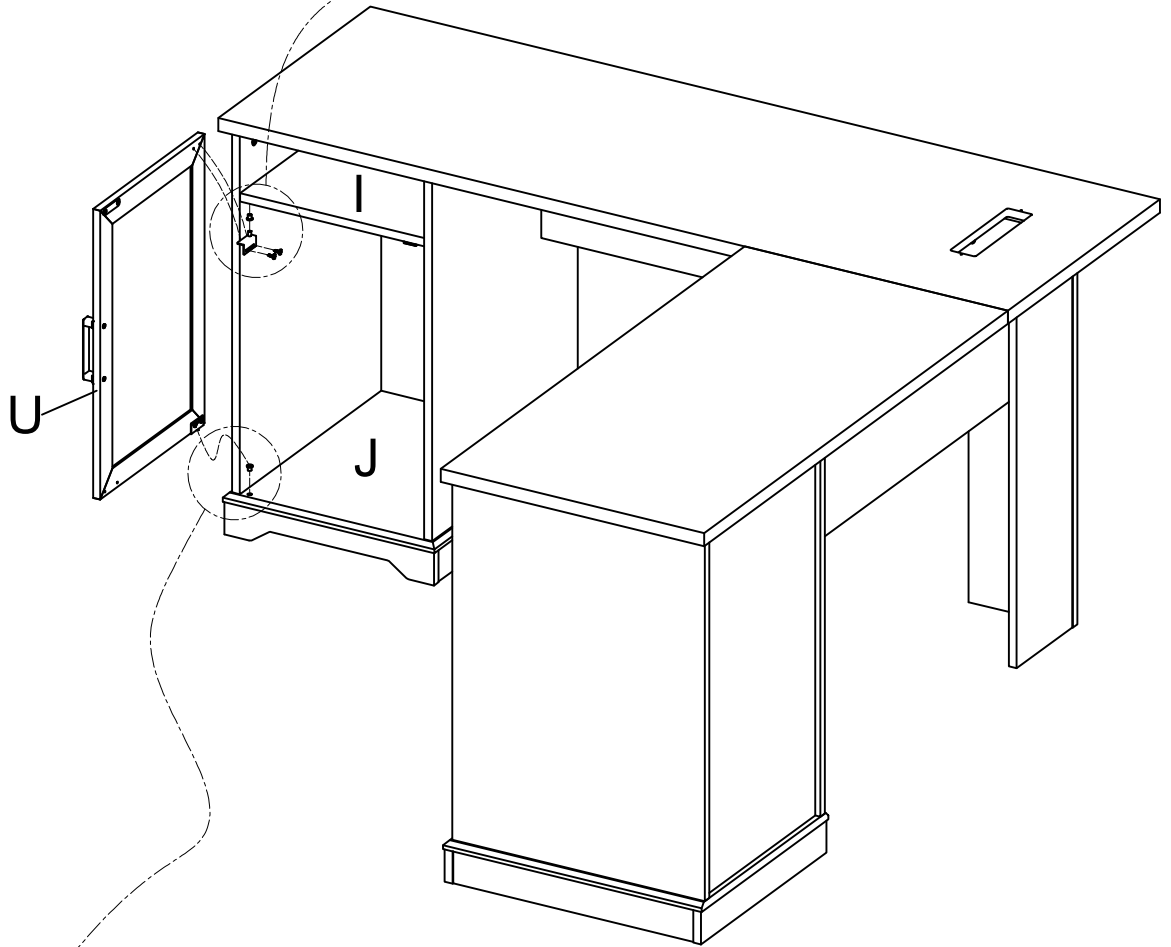

Step 1



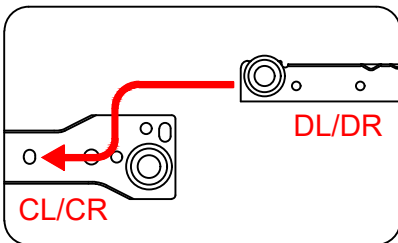
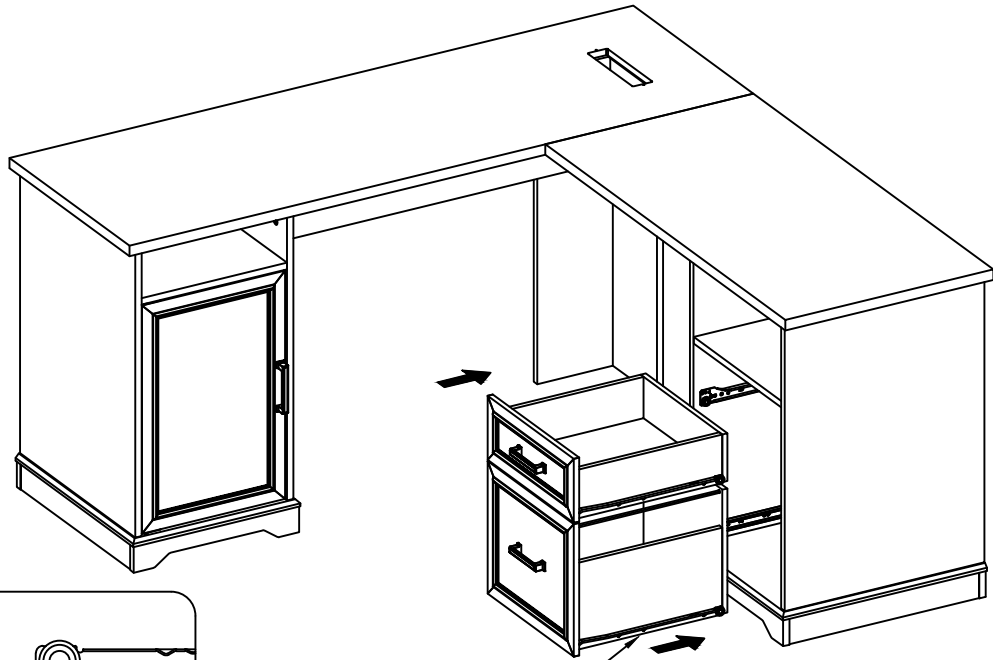

STEP 36

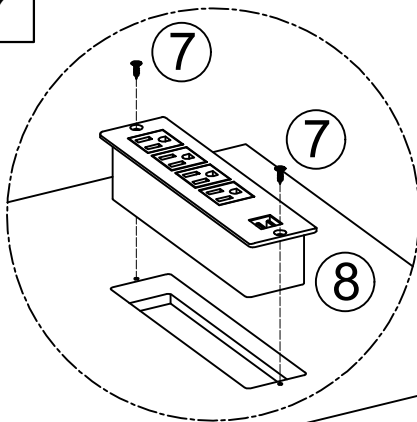

Please put the wheels align with the slots as the instruction shows, then slide into them

STEP 37



- 7  x2
- 8  x1

