

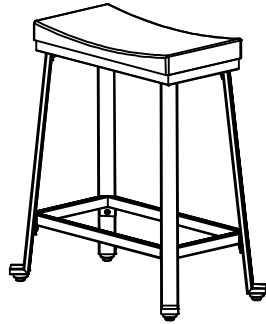

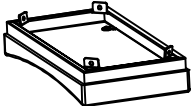



Assembly Instructions

SADDLE SEAT STOOL

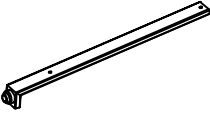

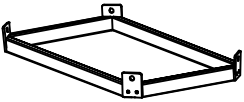
NO.	PART	DESCRIPTION	Q'TY	NO.	PARTS	DESCRIPTION	Q'TY
A		Saddle Seat	1PC	F		Spring Washer	8PCS
B		Leg	4PCS	G		Flat Washer	8PCS
C		Foot Rest	1PC	H		Allen Head Bolt 1/4" x 1/2"	8PCS
				I		Allen Head Wrench 4MM	1PC

Assembly Instructions

SADDLE SEAT STOOL

STEP 1

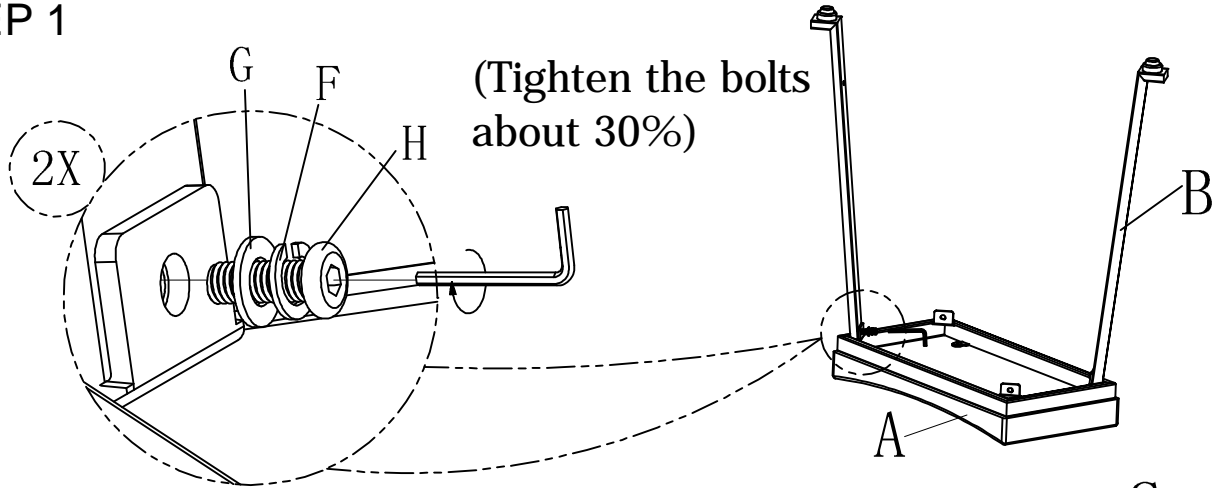

STEP 2

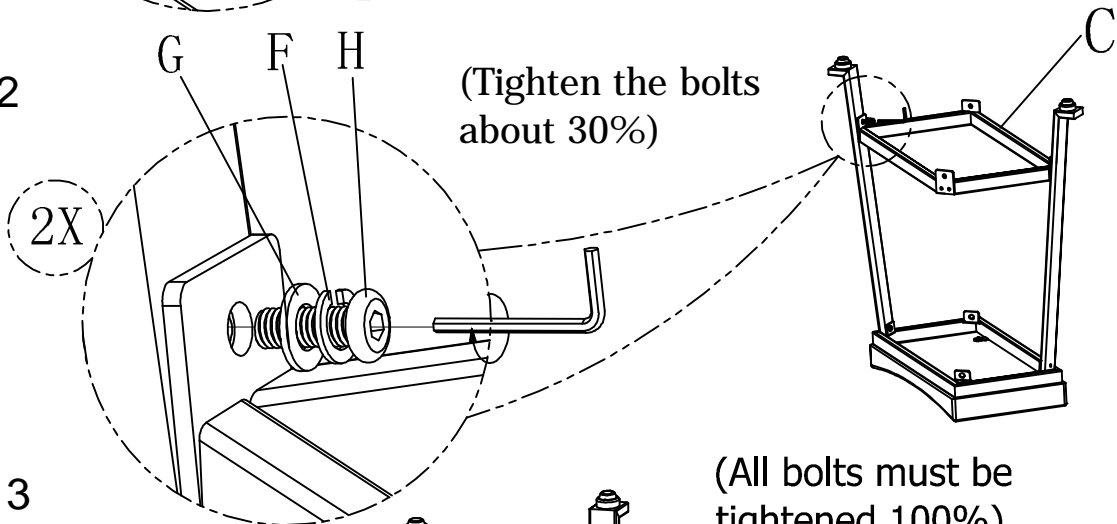

STEP 3

