

INSTALLATION INSTRUCTION

| | | | | | |
|------|-----|--------|-------|--------|-------|
| TYPE | ESM | WEIGHT | 2.3kg | LIGHTS | E26*4 |
|------|-----|--------|-------|--------|-------|

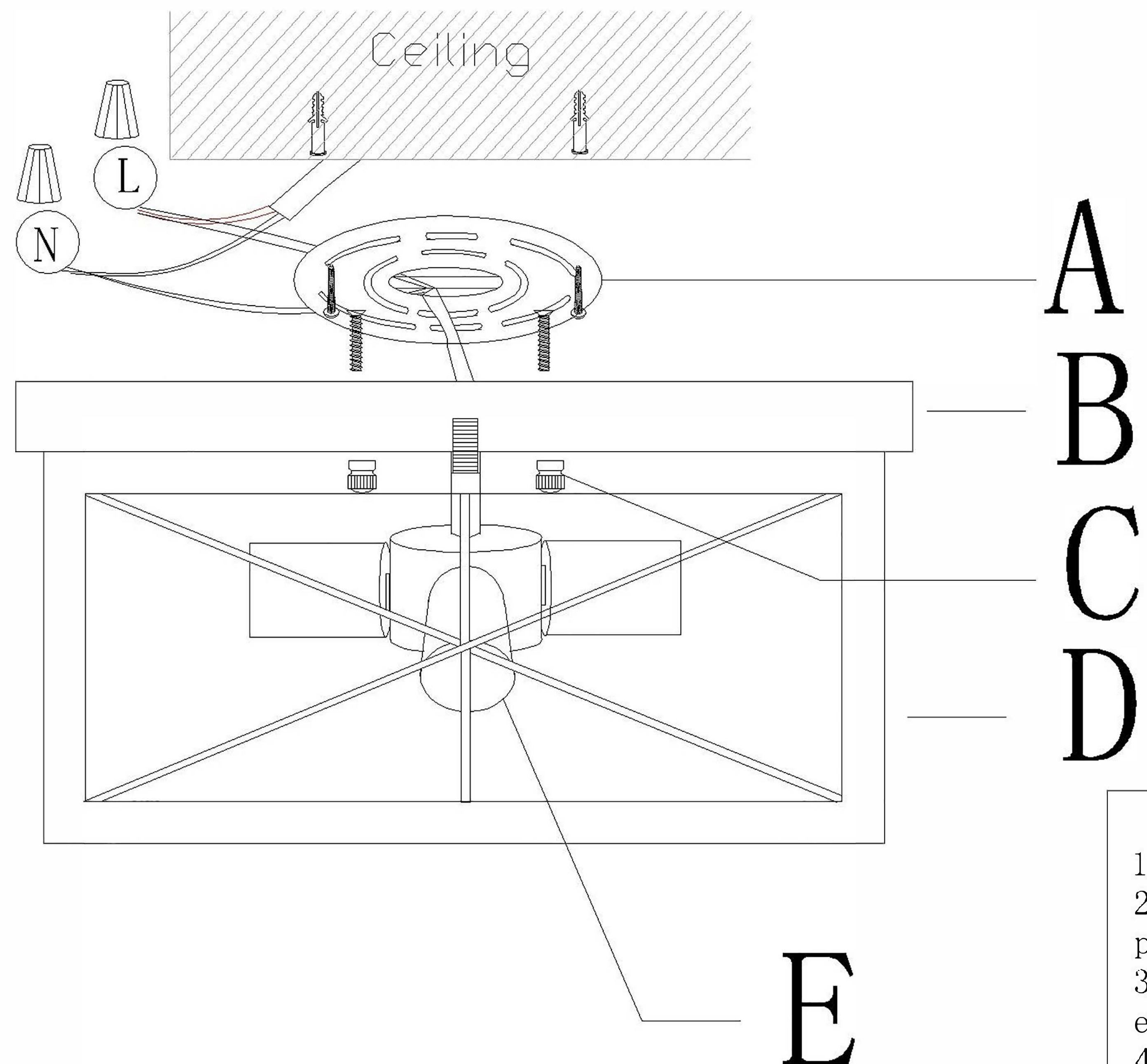

FRONT VIEW

| | |
|---|---------------------------------|
| Ⓐ | Mount Bracket |
| Ⓑ | Steel Canopy In Black Colour |
| Ⓒ | Screw Nut For Fixing The Canopy |
| Ⓓ | Wooden Lamp Frame |
| Ⓔ | Lamp Holders |
| | |

NOTE

1. Electrical appliances must only be connected by competent persons.
2. Before commencing installation work disconnect the mains cable from the power supply-removing the fuse or turning switch to "OFF"!
3. Do not attach lamps to surface which are damp, freshly painted, otherwise electrically conductive.
4. Use the suspension system according to the weight of the lamp.
5. Be sure to always use the correct type of bulb. (See information on the label)
6. Cleaning is limited to the outer surfaces, shades or protective glass, reflectors and covers.
7. Do not touch the bulb without any protective measures. Always switch off the electricity supply and allow to cool for 10 minutes before changing the light bulbs.
8. If the light is with crystal or glass, please follow below steps.
 - a. Check the packed bags with numbers then open them.
 - b. Hang the crystals to the right places according to the illustration.