

# 111SR e-Motion

## INSTRUCTION MANUAL



# THANK YOU FOR PURCHASING OUR MIRADOR 111SR e-Motion



This manual will provide you with clear and detailed instructions on how to safely and correctly assemble and maintain your pergola, to ensure it brings you many years of use and enjoyment.

## **IMPORTANT: RETAIN FOR FUTURE REFERENCE: READ CAREFULLY**

Warning: Important safety instructions. It is important for the safety of persons to follow these instructions. Please keep these instructions in a safe place.

This product can be used by children ages from 8 years and above and persons with reduced physical, sensory or mental capabilities or lack of experience and knowledge if they have been given supervision or instruction concerning use of the product in a safe way and understand the hazards involved. Children shall not play with the product. Cleaning and user maintenance shall not be conducted by children without supervision of an adult.

## **Intended use**

This pergola is intended for outdoor domestic use in residential environments, and to protect users from direct sunlight, glare and heat. Any use or modification to the pergola not included in this manual shall be considered as improper use, which may cause considerable danger to users and property and will void the product warranty.

For parts and customer service, please call +1 (877)-506-4777 in the U.S. and Canada (English and Spanish) Monday - Friday: 6:30 am - 4:30 pm, Saturday – Sunday: 8:30 am – 4:30 pm, Pacific Time. Or email: [support@miradoroutdoor.com](mailto:support@miradoroutdoor.com)

Digital instruction manual is also available on our official website [www.miradoroutdoor.com](http://www.miradoroutdoor.com) for your reference.

# TABLE OF CONTENTS

- Before Assembling Your Pergola	3
- Important Safety Advice	5
- Technical Data	8
- List of Parts	9
- Assembly	11
- Operation of Your Mirador Pergola	30
- Problem Solving, Care & Maintenance	32
- Warranty & Complaints Procedure	35
- Disassembly & Disposal of the Product	36
- Certification Information	37

# BEFORE ASSEMBLING YOUR PERGOLA

**WARNING: Important safety instructions. Follow all instructions, since incorrect assembly can lead to severe injury.**

**Make sure you have all the tools required for assembling your pergola:**

In order to assemble your pergola safely and correctly, please ensure you have access to the following tools and accessories, all of which are not provided.



Hard hat



Protective gloves



Phillips screwdriver



Tape measure



Leveler

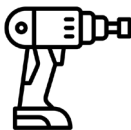

Cordless screwdriver



Hexagonal spanner/  
wrench set



Hammer drill



Hammer



2 Stepladders

### Check to ensure there are no missing parts:







Before you begin assembly, please check that you have all the parts required to assemble your e-Motion. Please also carefully check that the quantity of parts matches with that of the model you have purchased.

If any parts are missing, please refer to the **Warranty & Complaints Procedure** to contact customer service before beginning the assembly.

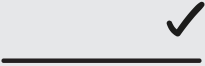
### Prepare the parts you will need for each step:

In the **Assembly** section of the manual, each step indicates the necessary parts and quantities required to complete the step. We recommend that you prepare the parts you will need for each assembly step. Doing this will save you time and effort during assembly. If possible, place the parts on cardboard or other soft surface to protect from scratching the painted surfaces.

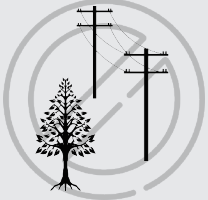
### Select a suitable location:

The ground should be solid and flat	The ground should be level	Sufficient water drainage	Easy access to power	No overhanging trees and powerlines
				
				

### Warning:

Most terraces or patios are designed with a slight slope to prevent (rain) water from forming pools or reaching the house or other structures. For the perfect pergola installation, a level concrete surface without such a slope is required. Small pebbles could also prevent the pergola from being safely secured on the ground.

If the pergola is installed on an uneven surface, it may prevent accessory components from working correctly and may void the product warranty.

### Prepare a foundation:



To prepare it, you need to:







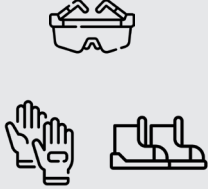
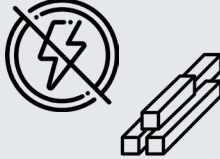
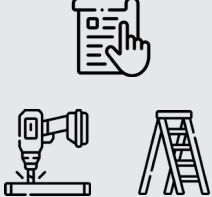
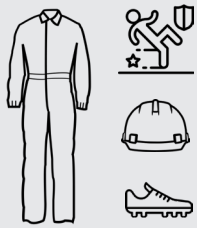

- check for underground pipes and cables (Call 811 before you dig if you live in the USA)
- check with your local authorities regarding any building permits that may be required
- contact a reliable contractor to install a concrete base if you don't have one

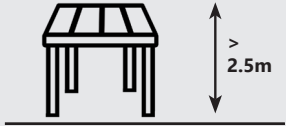
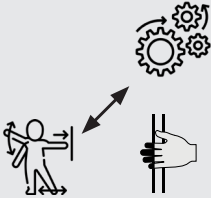
Do not assemble the pergola on sandy, muddy or loose soil, as the stakes do not have the sufficient anchorage to be installed in these types of soil.

# IMPORTANT SAFETY ADVICE

**For the safety of all persons assembling and using the pergola, it is important to follow the safety guidelines below.**

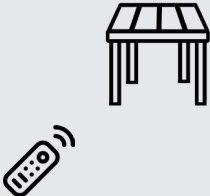
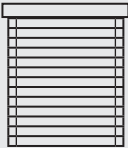
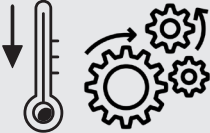
<p>The pergola must be positioned and fixed on flat level surface.</p>	<p>Always wear appropriate work shoes, gloves and eye protection when working.</p>	<p>Work well away from power lines, particularly when handling metal parts.</p>	<p>If using power tools or a ladder, always follow the manufacturer's safety instructions.</p>
			
<p>Make sure the pergola complies with local building regulatory codes.</p>	<p>Working at heights can be dangerous. Always wear protective clothing to prevent injury in the event of a fall.</p>	<p>Only use ladders and scaffolding with a sufficiently high load bearing capacity.</p>	<p>Before installing the drive, remove any unnecessary cords and disable any equipment not needed for powered operation.</p>
			

<p>Hazardous unprotected moving parts of the drive shall be installed higher than 2.5m above the floor or other level that could provide access to it.</p>	<p>Keep clothing and body parts away from the pergola to prevent them from getting caught in the moving parts.</p>	<p>Foliage or other foreign objects on the louvers and in the guide rails should be removed regularly, to prevent damage to the pergola.</p>	<p>Put the louvers into the vertical position during snowfall or wind to avoid damage.</p>
			
<p>Only use replacement parts that are approved by the manufacturer.</p>	<p>Electrical installation may only be carried out by certified personnel according to the applicable regulation. (e.g. VDE 100 for Europe)</p>	<p>Make sure all electrical connections are disconnected from the mains during installation.</p>	<p>Mirador electric pergolas should only be connected to power sources that have been installed by a licensed electrical contractor.</p>
 <p>✓ Approved</p>			
<p>The pergola should only be remote controlled when you have a full view of the moving parts.</p>	<p>Installation of non-Mirador branded accessories will void the product warranty and can damage the operating mechanism.</p>	<p>Repeated open-close operations may cause the motor to enter overheat protection mode. It will resume normal operation once the temperature decreases.</p>	<p>Dispose of all plastic bags safely. Keep them out of the reach of children.</p>
	 <p>Mirador®</p>		

Keep children and pets away from the assembly area until the work is completed.



Changes to the design or configuration of equipment may not be made without consulting the manufacturer or authorized representative.



Prior to each operation, visually check the pergola for damage. If damage is visible, stop using it immediately and contact authorized personnel to repair the damage.



If the supply cord is damaged, it must be replaced by the manufacturer, its service agent or similarly qualified people in order to avoid a hazard.



Do not climb on the louvers.



Do not attempt to assemble the product if you are tired, or after consuming alcohol.



Do not place anything on the louvers.

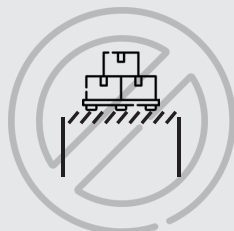

Do not attempt to assemble the pergola in windy or wet conditions.



Do not start the roof mechanism in case of frost or ice build-up, as it may damage the drive of the louvers.



Do not allow children to contact the fixed controls. Keep remote controls away from children.



Hanging objects on the pergola may cause serious damage and is not permitted.



Hot items such as recently used grills, fire pits etc. must not be stored under or close of the pergola.



# TECHNICAL DATA

<b>Pergola</b>	Continuous Operating Cycle	10 cycles
	Sound Pressure Level	≤70 dB
	Ingress Protection Rating	IPX5
	Wind Resistance	Class 6 ( Claimed Beaufort Wind Force Scale 11 )
<b>Linear Actuator</b>	Input Voltage	24V DC
	Ingress Protection Rating	IP66
<b>Control Box</b>	Input Voltage	24V DC
	Output Voltage	24V DC
	Ingress Protection Rating	IPX5
<b>Light LED Strip</b>	Input Voltage	24V DC
	Wattage Per Meter	11W
	Ingress Protection Rating	IP68
<b>Power supply</b>	Input Voltage	100 to 240V
	Ingress Protection Rating	IP67
	Maximum Power	320VA
<b>Control</b>	Control Method	Remote Control
	Remote control frequency band	2400MHz~2483MHz
	Remote control Max Transmit power	0dBm
<b>Data Center</b>	North America	West Coast: Oregon
		East Coast: Virginia

# LIST OF PARTS





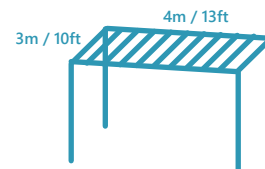

Please carefully check that the quantity of parts matches with that of the model you have purchased.











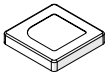

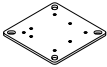





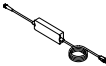



**PLEASE NOTE** that the anchor bolts provided may not be suitable for your chosen installation location. Please check before proceeding.

**DO NOT USE AN IMPACT CORDLESS SCREWDRIVER TO ASSEMBLE THE PERGOLA. USE A STANDARD CORDLESS SCREWDRIVER ON THE BASE SETTING. ALL HOLES HAVE BEEN PREDRILLED OR FITTED FOR ASSEMBLY.**



\*Extra spare parts included

REF		Part Name	QTY
A		Standard corner pillar	3
A2		Cabled corner pillar	1
B1		Side beam with motor	1
B2		Side beam without motor	1
C		End beam	2
D		Louver	25
G		Connecting strip	2

	REF	Part name	QTY		REF	Part name	QTY
I		Foot plate cover	4	W		Anchor bolt M8 x 80 mm	16
J		Foot plate	4	X		Hex key S4	1
K		Louver end cap	49+1*	Y		Hex key S6	2
L		Louver end cap with control arm	1	Z		12 mm SDS Plus Drill Bit	1
M		Shaft support cover	50+2*	Z4		Power supply	1
N		Pillar cover	3	Z5		LED light strip	2
N2		Pillar cover ( logo )	1	Z6		Remote control	1
O		Screw ST5.65 x 45 mm	28+2*	Z7		2.4G Antenna	1
P		Screw M5 x 12 mm	100+5*	Z8		Waterproof tape	1
Q		Screw ST4.2 x 25 mm	100+5*	Z9		Screw ST4.8 x 13 mm	4
R		Screw ST5.5 x 19 mm	16+2*	Z10		Spare plastic pin	0+10*
S		Cotter pin	50+8*				

# Assembly

## 1. Set up the corner pillars



Assembly Video

### 1A

Fix the cable flange with screws **Z9** onto the cabled corner pillar **A2**, and make sure the cable is hanging outside.

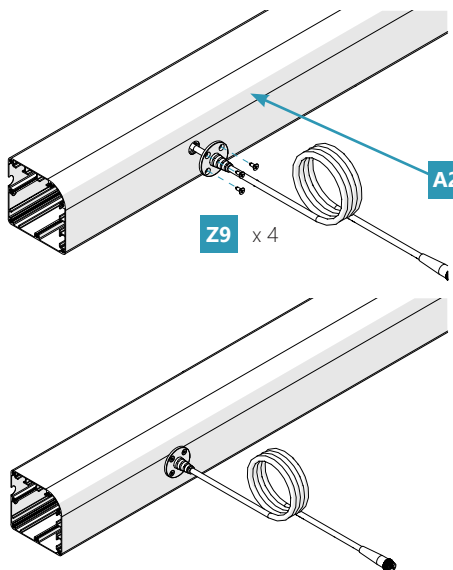
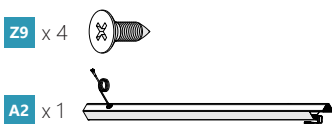

### 1B

Slide the foot plate cover **I** with its wide opening facing outwards on the straight end of the cabled corner pillar **A2**.

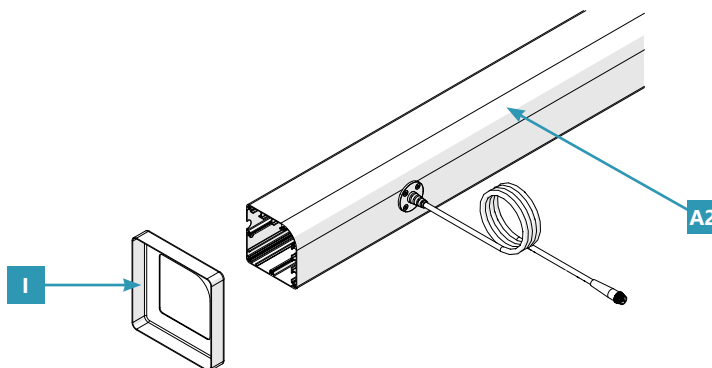
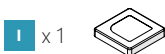

# 1C

Push the foot plate **J** against the straight end of the cabled corner pillar **A2**. It only fits in one direction and in one position. If in doubt, rotate it until it fits easily.

Screw in the foot plate **J** with 7 screws **O**.

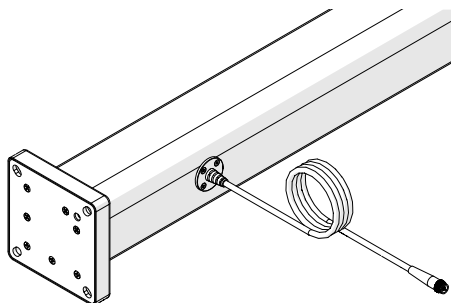
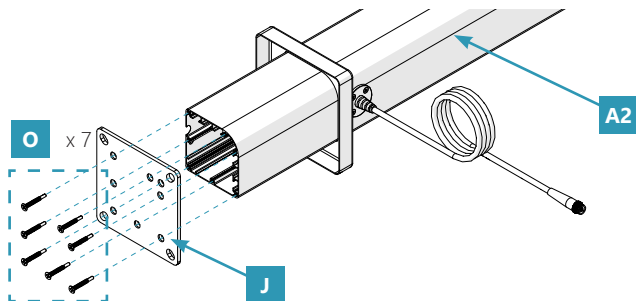

# 1D

Repeat steps **1B** – **1C** to assemble the foot plates **J** of the 3 standard corner pillar **A**.

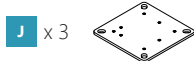
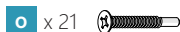
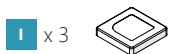

x 3

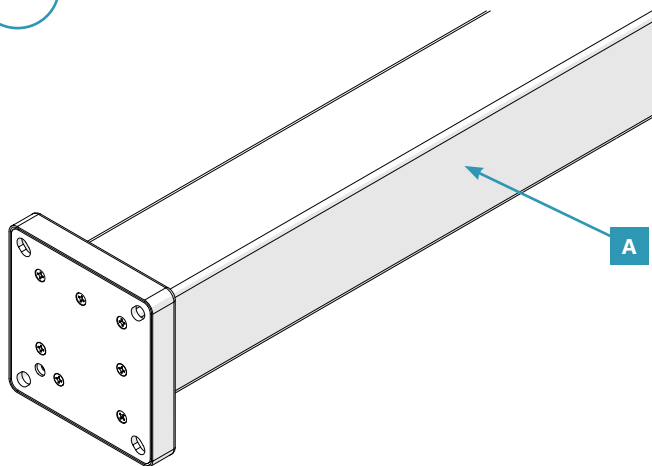

## 2. Connect side beam to the corner pillars

### 2A

Pull out the cable at the end of the side beam with motor **B1** through the small cut-out.

**B1** x 1 

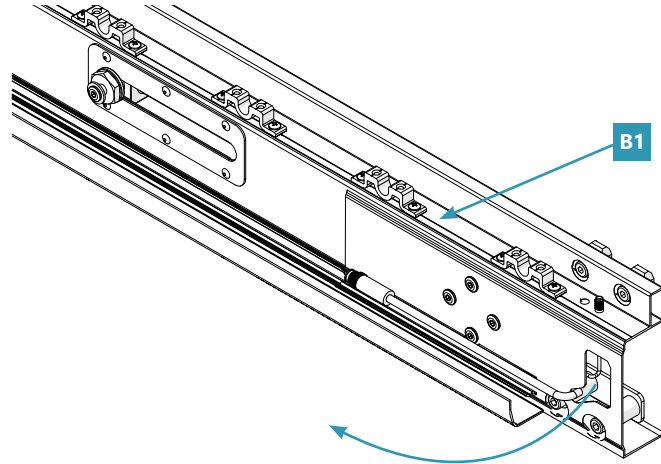

### 2B

Using a hex key **Y**, slightly loosen the 8 built-in screws at the both ends of the side beam with motor **B1** (4 on each side).

**Y** x 1 

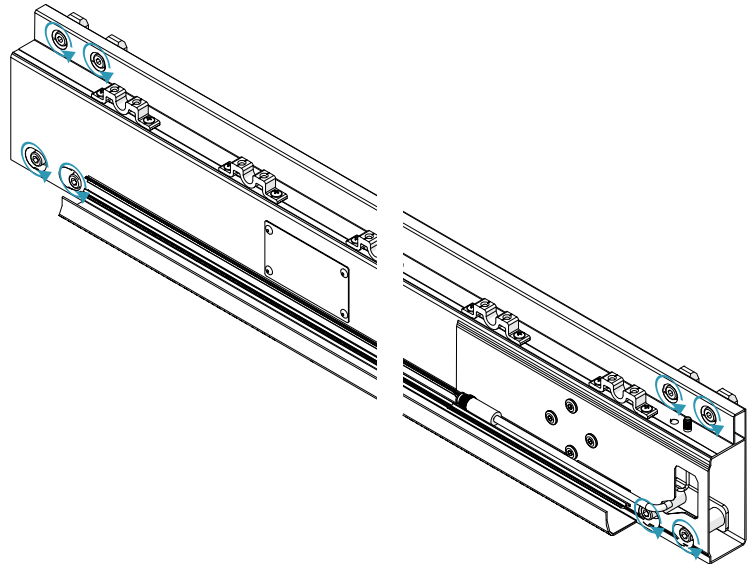

## 2C

Lay two corner pillars ( **A** & **A2** ) and place the side beam with motor **B1** on the floor as shown in the picture.

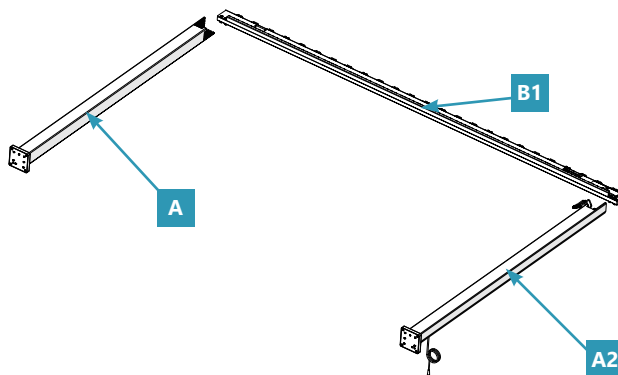
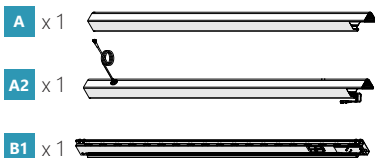

## 2D

Slide side beam with motor **B1** into the grooves of the corner pillars ( **A** & **A2** ) in such a way that the slot nuts of the side beam with motor **B1** interlock with the slots in the corner pillars ( **A** & **A2** ).

**Notice:**  
Pull the cables out of the cabled corner pillar. Take care not to crush or squeeze the cables.

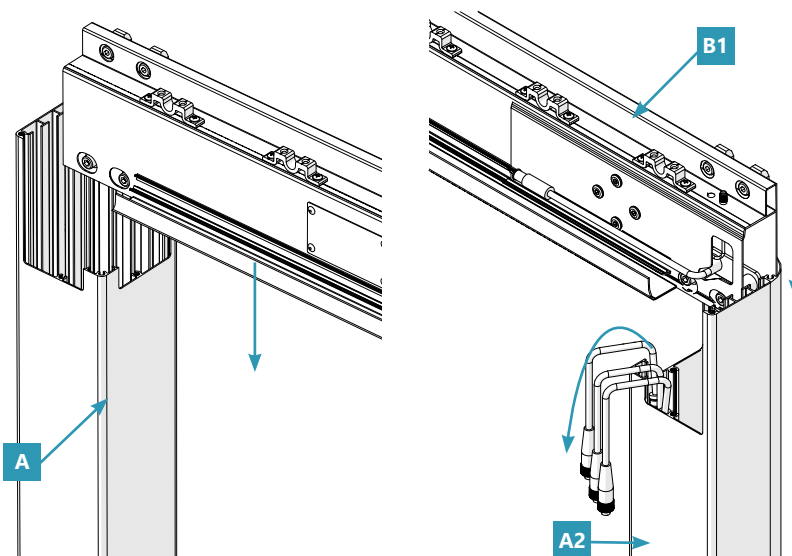

## 2E

Tighten the 8 screws ( 4 on each side)  
with the hex key **Y** .

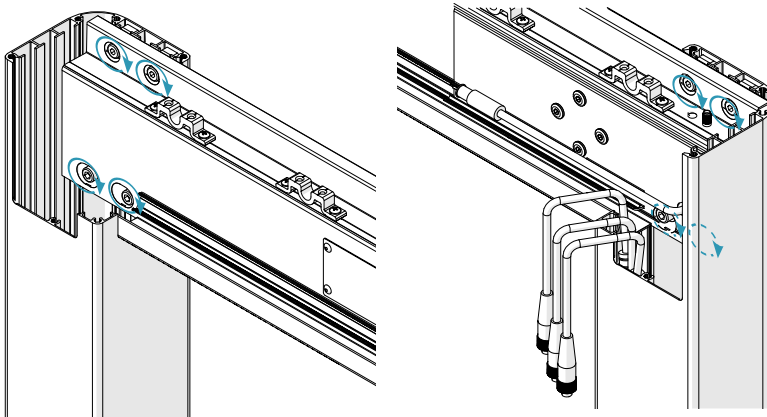

**Y** x1

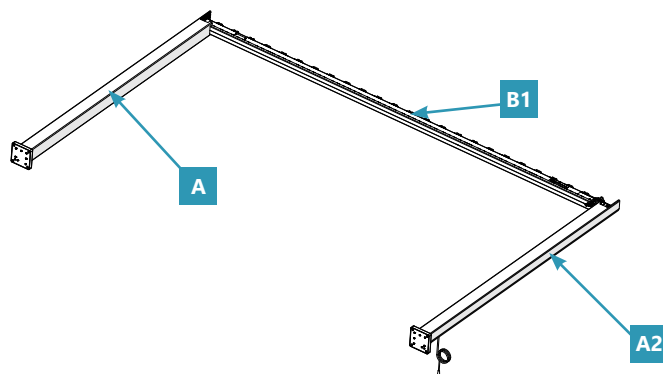

## 2F

Repeat steps **2B** - **2E** to connect  
the beam without motor **B2** with the  
remaining two corner pillars **A** .

**Y** x1



**B2** x1



**A** x2

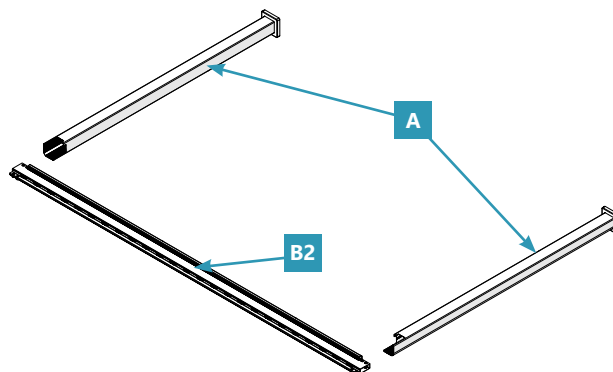

# 3. Slide in the two end beams

This phase requires four persons and at least two stepladders. Make sure that the stepladders are standing securely to avoid falling.



Only use ladders suitable for this kind of assembly work.

## 3A

Stand the two structures built in **steps 2** in an upright position, and place them at one end beam length away from one another. Make sure that one person is supporting each corner leg ( **A** & **A2** ) to prevent the structures from falling.

### Notice:

When determining the assembly direction of the product, please consider the opening direction of the louvers as well as the desired sunshade effect.

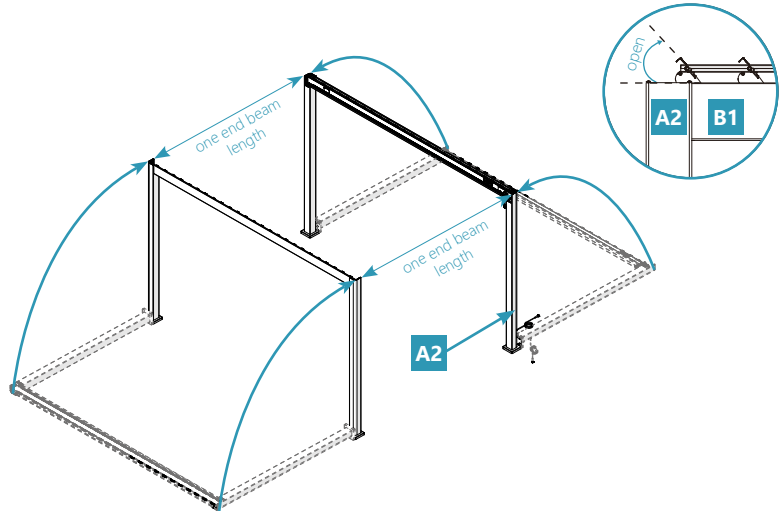

## 3B

Slightly loosen the 8 built-in screws at both ends of the end beam **C** .

**Y** x1



**C** x1

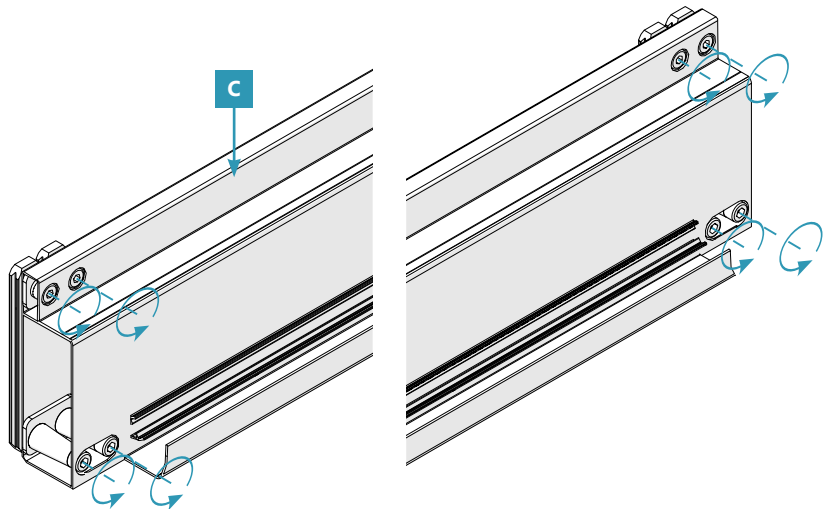

### 3C

Slide the slot nuts of the end beams **C** from above into the slots of the corner pillars **A**.

**C** x1

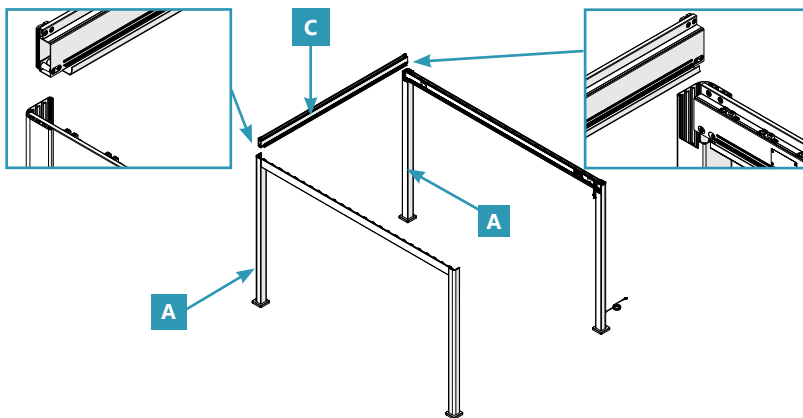

### 3D

Once the beam is in the correct position, tighten the 8 built-in screws on both ends using the hex key **Y** provided.

**Y** x1

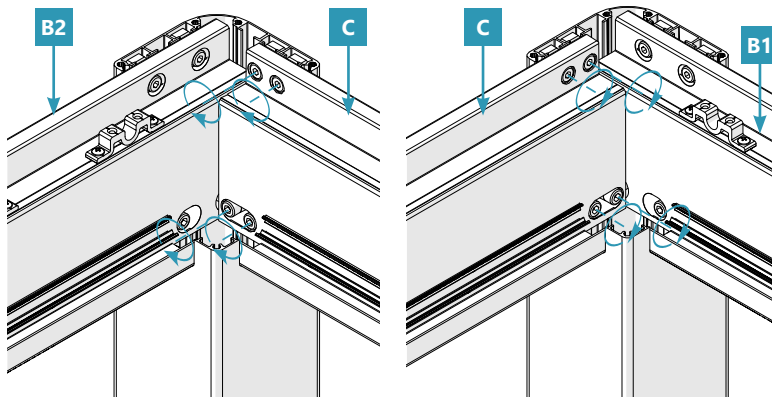

### 3E

Assemble the other end beam **C** by repeating steps **3B** - **3D**.

**Y** x1



**C** x1

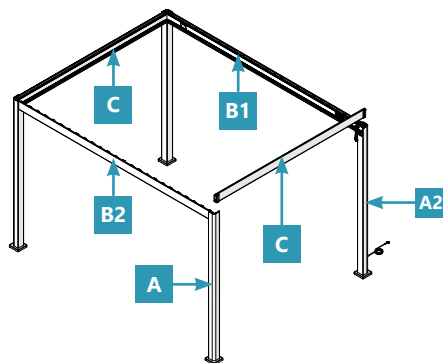

## 4. Install the LED strip lights

### 4A

Place both LED light strips **Z5** along the grooves on the side beams (**B1** & **B2**) and end beams **C**, as shown in the figure. Put the connection socket of the LED light strip **Z5** close to the cabled corner pillar **A2**, and put the end of the LED light strip **Z5** into the top of the corresponding corner pillar if needed.

**Z5** x 2

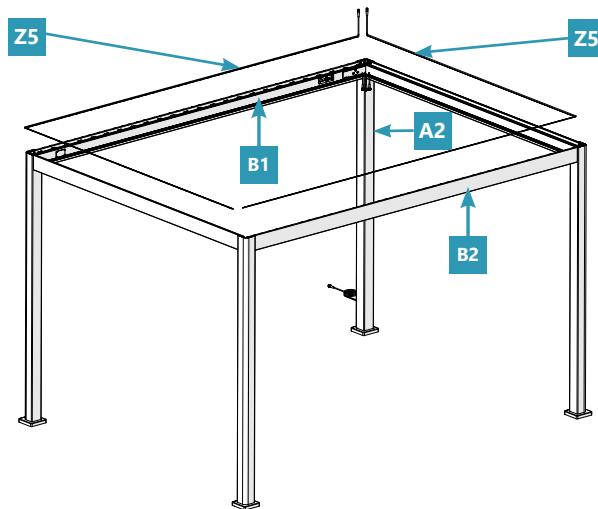

### 4B

As shown in the figure, press both LED light strips **Z5** firmly into the light strip slots one by one to ensure they are fitted evenly.

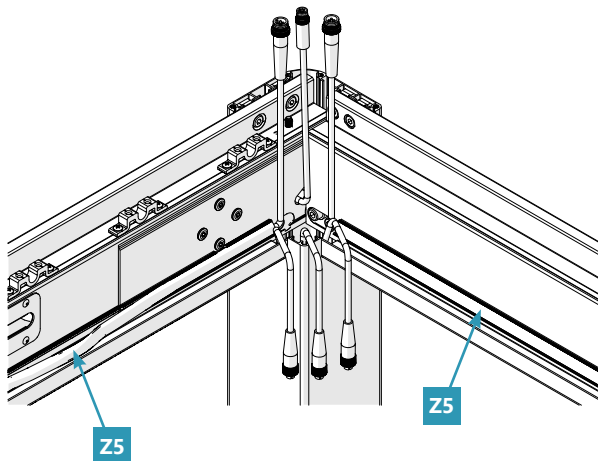

# 5. Connect the power cables of the motor and LED strip lights

## 5A

Connect the cable connector (5-pin) of the side beam with motor **B1** into the corresponding connector socket on the top of the cabled corner pillar **A2**. Then tighten the waterproof connector.

Connect the cable connector (4-pin) of the LED light strip **Z5** into the corresponding connector socket on the top of the cabled corner pillar **A2**. Then tighten the waterproof connector (there is no need to differentiate the plug sockets of the two light strips as they are the same).

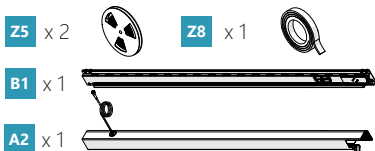

### Notice:

It is recommended to wrap waterproof adhesive tape on the waterproof connectors to prolong their service life.

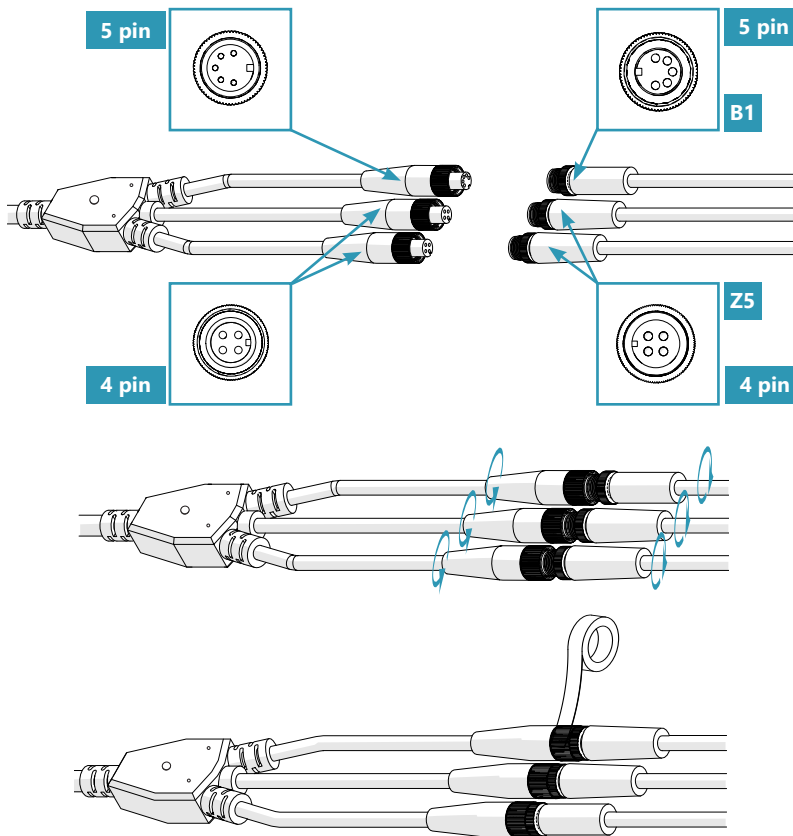

## 5B

Carefully tuck all connected cables and connectors at the top of the structure back into the corner pillar.

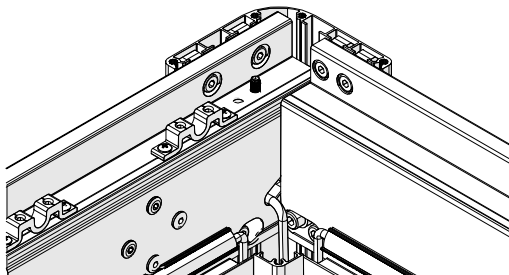

## 6. Check the alignment of the frame and the distance between the corner pillars

You are now almost done assembling the main frame of the pergola. Please double check to ensure all corner pillars, beams, and cables have been assembled and fitted correctly. You may have to unscrew certain bolts during this step.

You will also need a tape measure and a leveler to complete this step.



### 6A

Choose one of the corner pillars ( **A** & **A2** ) and work from this pillar.

Choose this pillar carefully as it will define the final installation location of the pergola.

Use a leveler to measure against both of the inner sides to ensure that the corner pillar is straight and level.

Make sure this corner pillar does not move position during the remaining assembly steps.

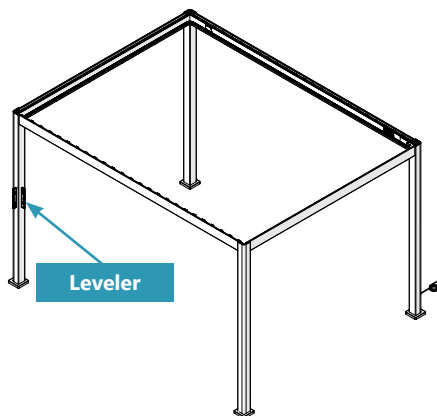

### 6B

Measure the distances between the adjacent corner pillars. Adjust accordingly and ensure the distances match those shown in the opposite figure.

**a** = 279.05cm / 109.9 inches  
**b** = 370.5cm / 145.9 inches

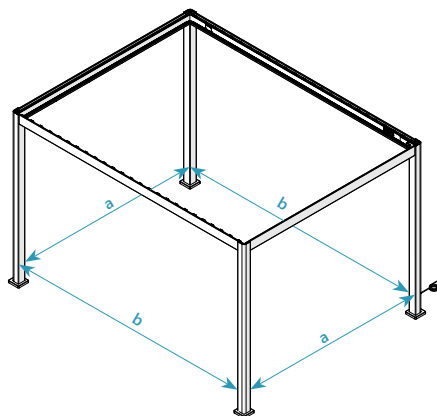



## 6C

Measure the diagonal distance between the opposite corner pillars. Adjust the other corner pillars accordingly until both diagonal distances are equal. You may have to repeat the above steps after completing the remaining steps.

a = 464.3cm / 192.8 inches

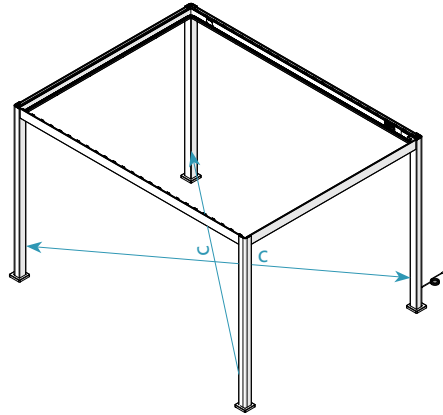

## 6D

Check that all corner pillars are straight and level using a leveler. If the corner pillars or beams are still not level, this means that your main building surface isn't sufficiently level, and that you will need to raise the corner pillars that are positioned lower than the others. (Contact qualified professional installers if needed.)

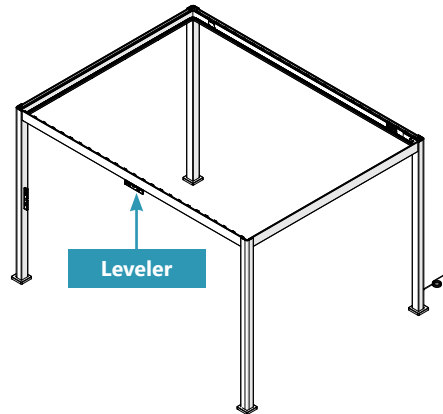

### Warning:

If you do not adjust the main structure at this point, you may encounter problems when fitting the roof deck and/or accessories to the frame.

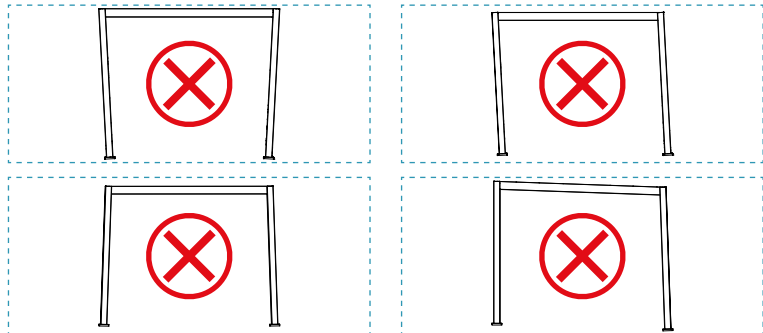

# 7. Assemble the louvers



## 7A

Prepare the driving louver: select one of the louvers **D** to be the driving louver.

Attach the louver end cap with control arm **L** to one end of the driving louver, and attach an louver end cap **K** to the other end of the driving louver. Use 2 screws **Q** on each side.

### Notice:

Do not over tighten or strip out the screws.

**L** x 1



**Q** x 4



**K** x 1



**D** x 1

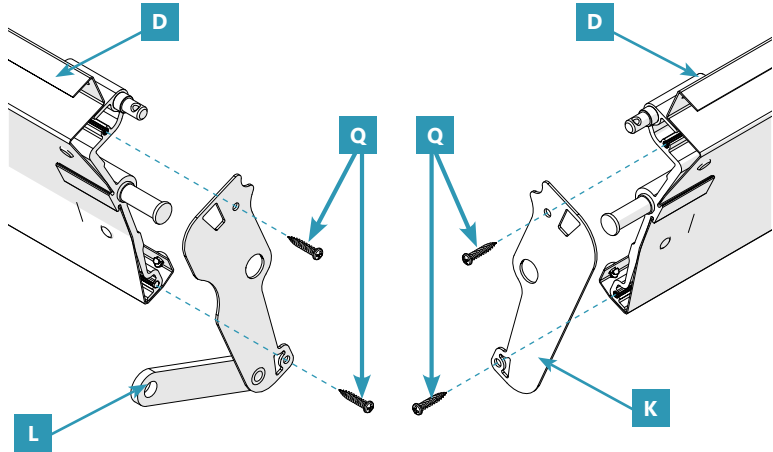

## 7B

Prepare the regular louvers: attach the louver end caps **K** to each end of the rest of the louvers **D** with 2 screws **Q**.

Repeat this step for all louvers.

**Q** x 96



**K** x 48



**D** x 24

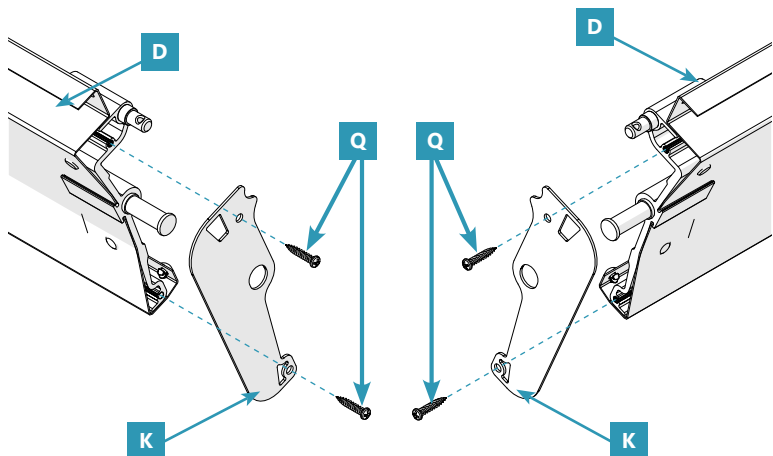

# 7C

Loosen the screw and washer already attached to the beam with motor

Then fix the connecting rod **L** of the driving louver to the side beam with motor **B1**, by firmly tightening the same screw and washer, using the hexagon socket key **X**.

Place the louvers **D** on the corresponding louver shaft support on both side beams (**B1** & **B2**), with each louver overlapping the next, and **make sure that the driving louver is placed 4th from the right**.

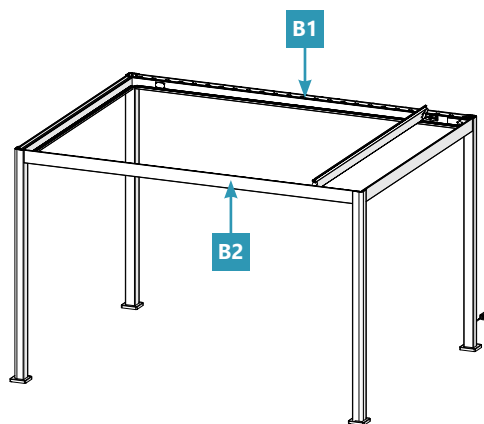
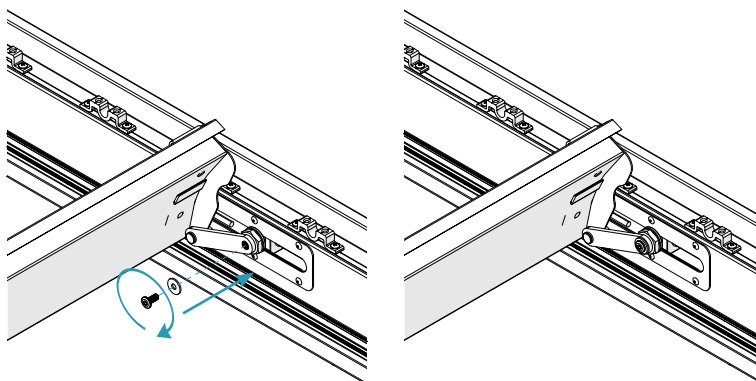
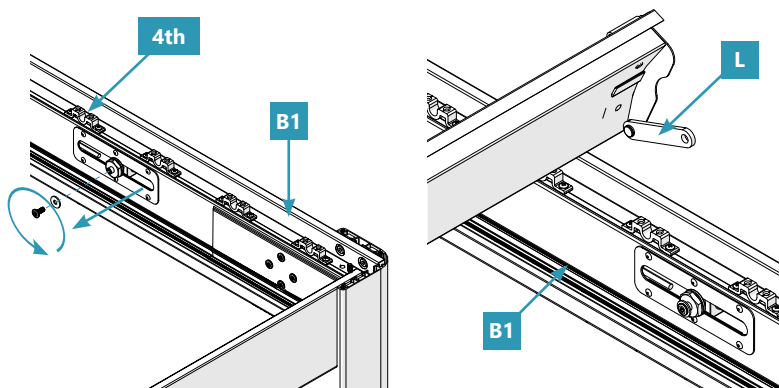

**X** x1





# 7D

Place the rest of the louvers onto the remaining shaft support brackets.

Secure the louvers **D** in the shaft support brackets by fixing a shaft support cover **M** onto the shaft support brackets on both ends of each louver **D**. Use 2 screws **P** each and secure them.

Repeat this step for all louvers with each louver overlapping the next.

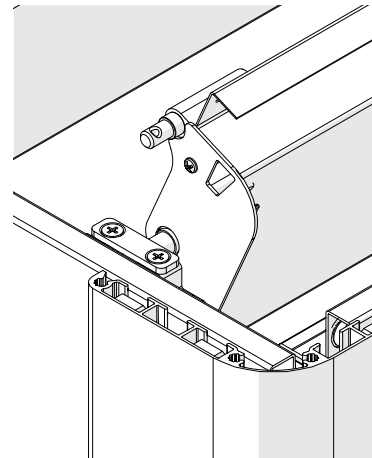
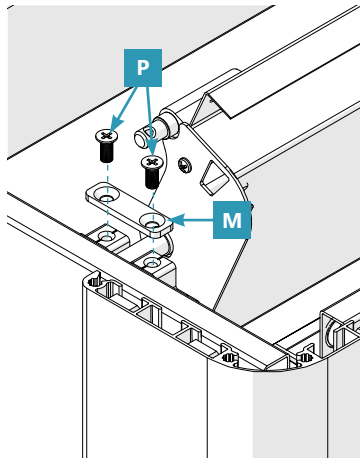
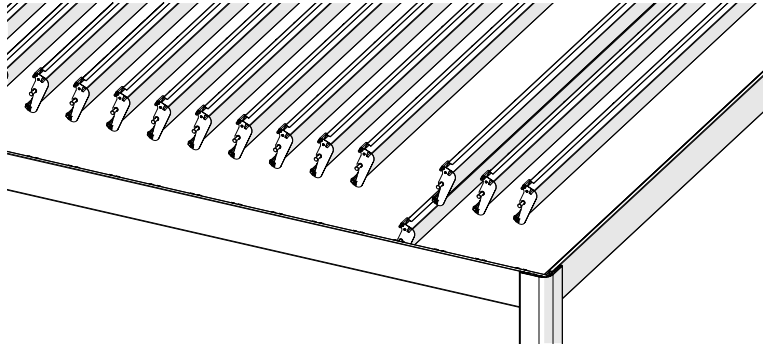
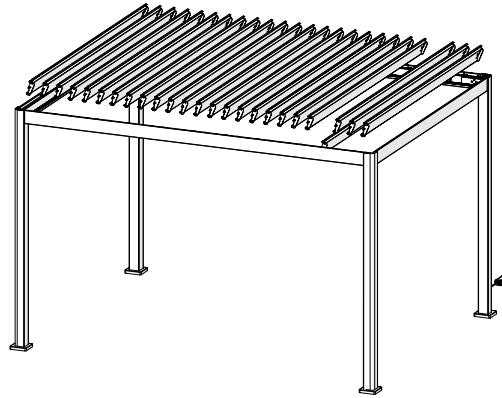

**M** x 50



**P** x 100



# 7E

Take the connecting strip **G**. Attach it to each louver fitting each of the holes onto the corresponding bolts of the louvers. Secure every bolt with a cotter pin **S**, inserting it through the small bolt hole.

Repeat this step for all cotter pins on both sides.

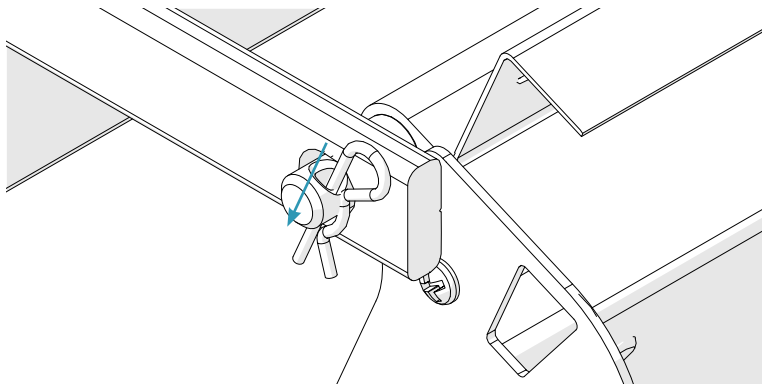
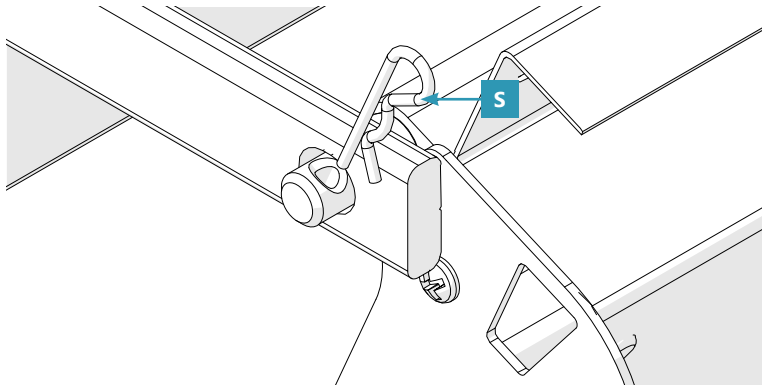
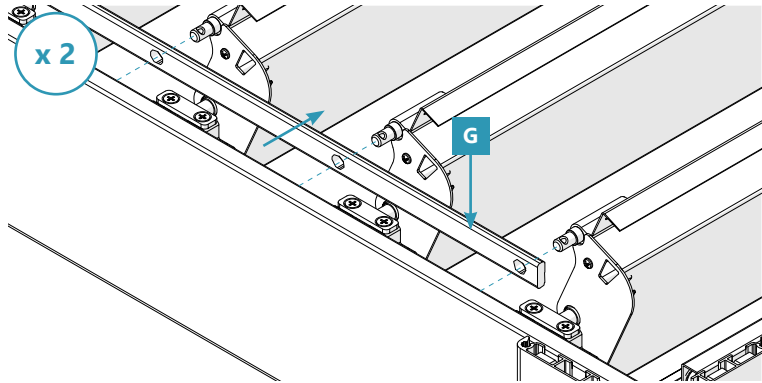

**S** x 50



**G** x 2



# 8. Finalize the electric connection and assemble the pillar covers

## 8A

Assemble the 2.4G antenna **Z7**, and make sure they correspond to the label on the side beam with motor **B1**.

**B1**

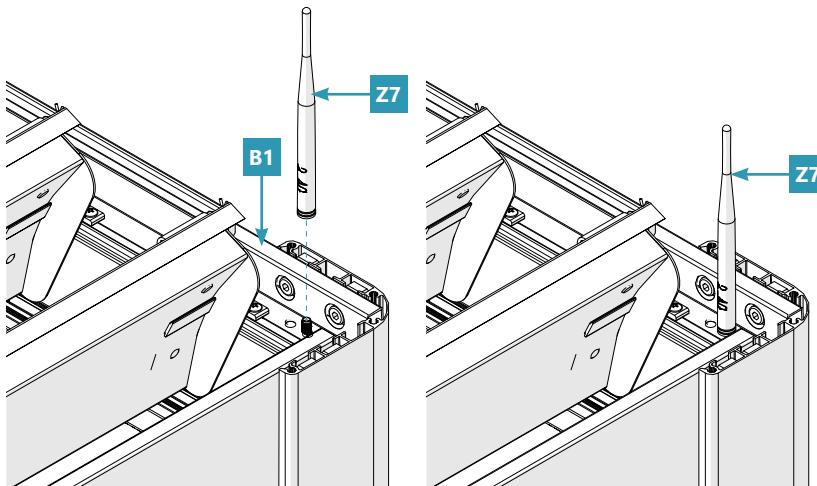

**Z7** x1



## 8B

Fix a pillar cover **N/N2** to the top of each corner with 4 screws **R** each.



x 4

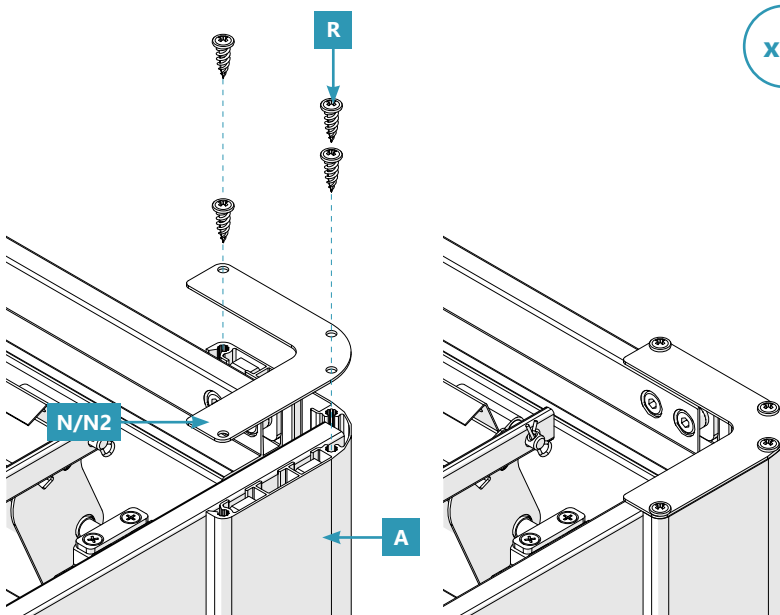

**R** x16



**N** x3



**N2** x1



# 8C

Connect the cable on the base of the cabled corner pillar **A2** to the cable of the power supply adapter **Z4**. Tighten firmly.

**Notice:**

It is recommended to wrap waterproof adhesive tape on the waterproof connectors to prolong their service life.

**Warning:**

Ensure the power supply adapter makes contact with the ground.

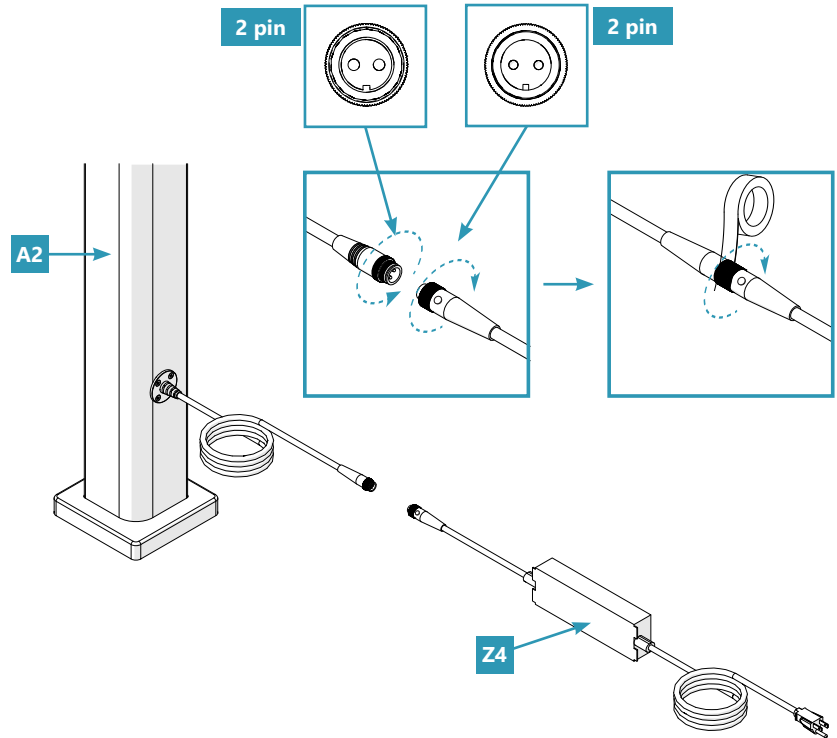

**Z4** x 1

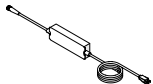

**Z8** x 1



# 9. Secure the corner pillars to the ground

The pergola must be firmly and permanently secured to the ground. If the ground is not level or suitable, please refer to the section “Before assembling your pergola”.

To ensure the correct installation of the subsequent fittings, check the frame alignment and pillar distance by repeating steps **6A** - **6D** .



**9A**

To fix the corner pillars ( **A** & **A2** ) with the four foot plates **J** , drill through each hole with a hammer drill.

**z** x 1

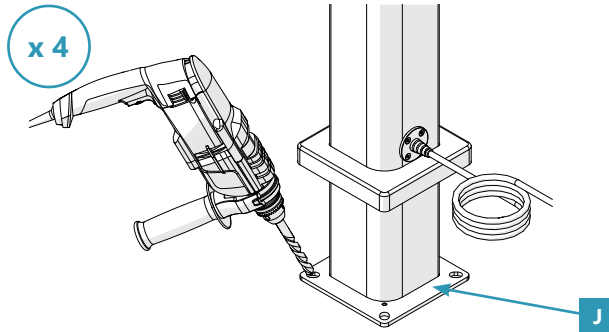

**9B**

Remove all the debris and dirt. Then firmly insert an anchor bolt **w** into each hole, using a hammer.

**w** x 16

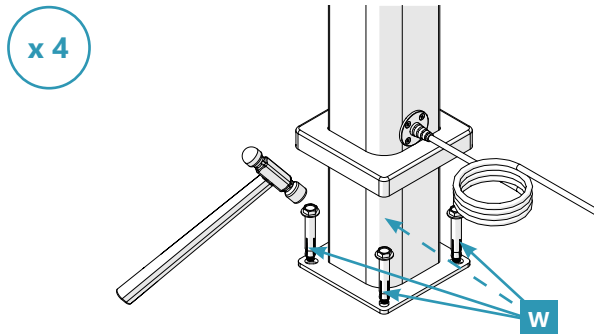

**9C**

Tighten the hexagonal ends of each bolt with a spanner/wrench.

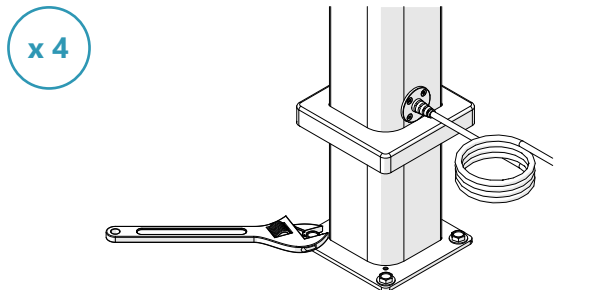

# 10. Construction Drawing

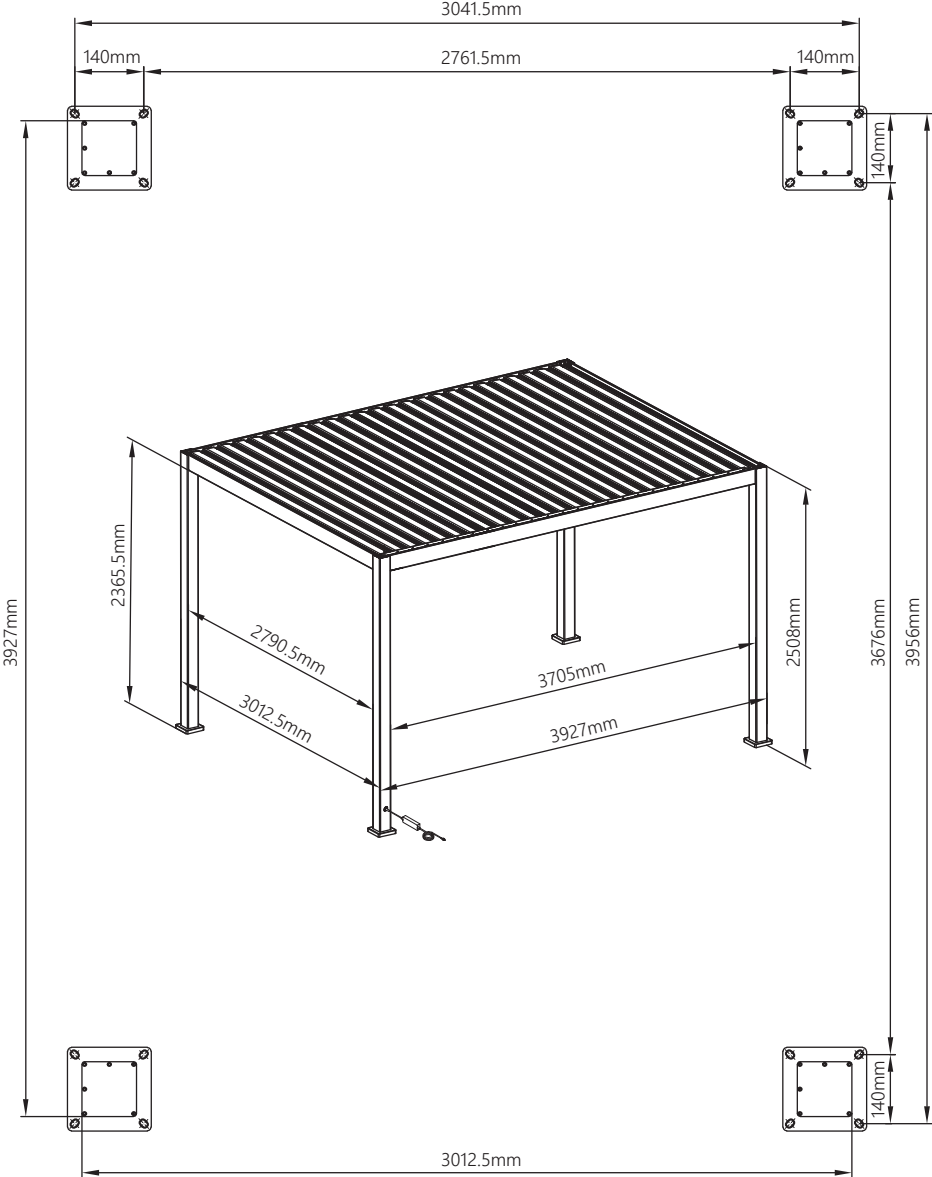

# OPERATION OF YOUR MIRADOR PERGOLA

## Plug the power supply adapter into the mains

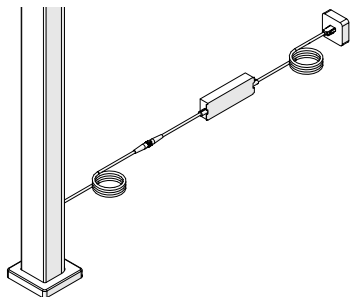

The LED light will light up for two seconds and then turn off to indicate that the device has successfully powered on.

If no light is observed, please sequentially inspect the indicator lights on the connectors at the positions indicated in the right picture.

If any indicator light is off, please reconnect the corresponding connectors according to assembly steps **5A** and **8C**. (Connector 2 should be pulled out from the pillar for inspection.)

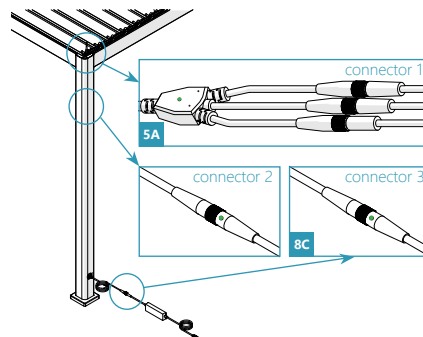

### Warning:

To reduce the risk of electric shock, this equipment has a polarized plug (one blade is wider than the other). This plug will fit in a polarized outlet only one way. If the plug does not fit fully in the outlet, reverse the plug. If it still does not fit, contact a qualified electrician to install the proper outlet. Do not change the plug in any way.

## Operate with the remote control

Insert the AAA batteries into the remote control **Z6** and press the appropriate buttons for lighting or louver adjustments.

If you encounter issues controlling the lights/ louvers or notice a delay while switching through the remote control, please re-pair the remote by following the **Pairing** steps outlined below.

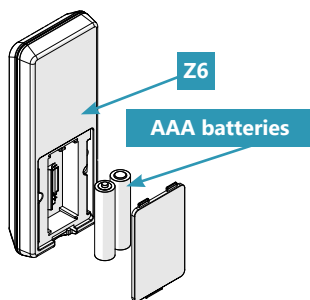

### Pairing:

1. Unplug the power supply and remove the battery from the remote control.
2. Wait for **15 seconds**, then reconnect the power supply and reinstall the battery in the remote control, make sure batteries are not worn out and that they are inserted correctly.
3. Once the light on the remote begins to flash, it indicates pairing mode has been activated. Please complete the pairing process **within 5 minutes** of reconnecting the power.
4. Simultaneously press and hold both **4** and **5** on the remote control.
5. After successful pairing, the light strip will flash twice and all louvers will move back and forth once.

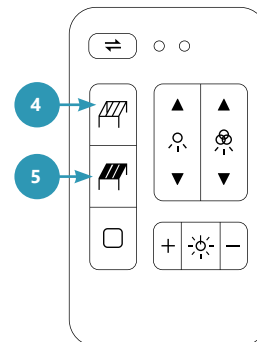

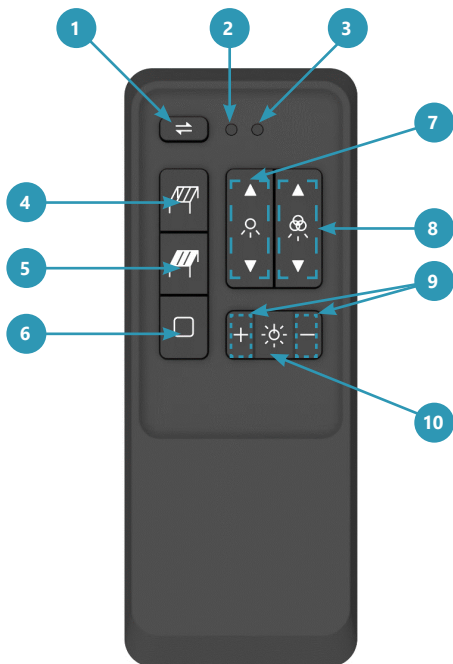

## Operating

- 1 Toggle to control actuator 1, actuator 2 or both actuators
- 2 Led indicator for actuator 1
- 3 Led indicator for actuator 2
- 4 Open louvers
- 5 Close louvers
- 6 Stop louver movement
- 7 Single color mode: Toggle light colors
- 8 Dynamic lighting mode: Toggle chasing effects
- 9 Adjust brightness (Only works for single color mode)
- 10 Turn on/off lights

## Warning

- Non-rechargeable batteries are not to be recharged.
- Different types of batteries are not to be mixed.
- New and used batteries are not to be mixed.
- Batteries are to be inserted with the correct polarity.
- Exhausted batteries are to be removed from the appliance and safely disposed of.
- If the appliance is to be stored unused for a long period, the batteries should be removed.
- The supply terminals are not to be short-circuited.



# PROBLEM SOLVING, CARE & MAINTENANCE



Issue	Explanation or Action to take
The LED light strip is deformed after removing it from the packaging.	Expand the light strip and leave it at room temperature for a period of time until its shape is restored before installing it.
The surface of the LED light strip oxidizes and changes color after long-term use.	Regularly clean the surface to ensure cleanliness. If necessary, order a replacement light strip.
Abnormal noise occurs during the rotation of the louver(s).	Check if any of the louvers are deformed. If this is the case, replace them. If the louvers are not deformed but they are colliding with one another, replace the beam.
The remote control cannot be paired with the control system.	Check if the product is powered on. Check if the remote control battery is installed or if the battery is depleted. Remove the rear cover of the remote control and check if the positive and negative poles of the battery are correct. Remove the battery and reinstall it to avoid poor contact. (The details can be reviewed in the page 31) If the problem still persists, please contact customer service.
The LED light strip operates normally, but the liner actuator does not.	Replace the beam with motor.
Some of the light beads on the LED light strip do not work according to the instructions.	Replace the light strip.

Issue	Explanation or action to take
The flatness of the louver is damaged due to weather conditions.	Replace the affected louvers.
The louvers cannot be reset when there is a power failure.	Remove the screws on the driver, take out the driver connected to the screws, and allow the louvers to reset automatically.
The drain is blocked by leaves or debris.	Clean the ducts and guttering of the pergola regularly.
The casting powder on the beam surface falls off after the motor runs for long periods.	No intervention is needed under normal circumstances.

## General Care & Maintenance

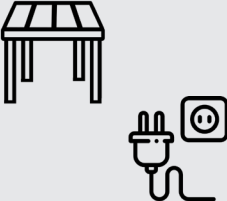
Dust and dirt will collect on the pergola and will require periodic cleaning	Use a water/detergent mixture and a soft clean cloth to clean the pergola.	Air dry or wipe with a soft clean cloth	Do not operate the awning when maintenance, such as window cleaning, is being carried out in the vicinity.
			

<p>For more soiled areas, rinse the surface with clean water from top to bottom.</p>	<p>In most situations it is not necessary to lubricate the moving parts of the pergola. However, when squeaking occurs, using a silicone spray lubricant is recommended.</p>	<p>Do not use any petroleum based spray lubricant.</p>	<p>Disconnect the awning from the supply when maintenance, such as window cleaning, is being carried out in the vicinity.</p>
	 <p>Silicone based</p>	 <p>Petroleum based</p>	

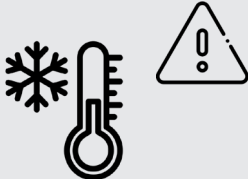
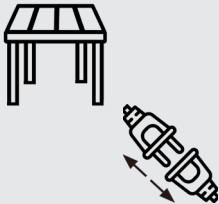
<p>In coastal areas, it is recommended that you frequently spray the pergola with water to reduce accumulation of salt and dirt.</p>	<p>Disconnect the cables if the pergola is not being used for long periods.</p>	<p>When the temperature is below 0°C/32°F, it is recommended to use the product less frequently to prolong the product's service life.</p>	<p>The drive shall be disconnected from its power source during cleaning, maintenance and when replacing parts.</p>
		 <p>&lt; 0°C / 32°F</p>	

## Periodic inspection

**Frequently examine the installation for imbalance and signs of wear or damage to cables and springs. Do not use if repair or adjustment is necessary.**

- Check the pergola is fixed firmly to the ground.
- Check the pergola's mobile components are in good working order.
- Check that the driving parts are sufficiently lubricated.
- Check the condition of the electrical cables and inspect their mains connection.
- Check the operation of the motor's limit switch and correct where necessary.
- Check the screws and rivet joints on the pergola.
- Check of the condition of mobile roof and bearings.

# WARRANTY & COMPLAINTS PROCEDURE

**For terms and conditions of our limited warranty, please visit [www.miradoroutdoor.com](http://www.miradoroutdoor.com) or contact your local Mirador sales representative.**

## **Complaints procedure:**

- The complaint must include an order number or transaction number. Goods without an order number or transaction number are not covered under the warranty.
- The complaint must include a detailed description of the defect, the name of the company which assembled the product if 3rd party was used and the date when the defect was discovered.
- At Sorara Outdoor Living USA Inc's discretion, customer must offer supplier the photos/videos of the issue/damaged parts. Otherwise, supplier reserves the right to refuse replacement parts or credit.
- Please save a copy of your purchase receipt.

## **Contact:**

### **Phone**

+1 (877)-506-4777

**Operation hours:** Monday - Friday: 6:30 am - 4:30 pm, Saturday – Sunday: 8:30 am – 4:30 pm, PST.

**Language:** English and Spanish

### **E-mail**

[support@miradoroutdoor.com](mailto:support@miradoroutdoor.com)

**Operation hours:** We are available 24 hours a day. Please allow up to 24 hours for a response.

**Language:** English, Spanish and Canadian French

### **Online**

[miradoroutdoor.com](http://miradoroutdoor.com)

**Operation hours:** Monday - Friday: 5:30 am - 2:00 pm, Saturday – Sunday: 8:30 am – 4:30 pm, PST.

**Language:** English, Spanish and Canadian French

**Note:** Our team is available to assist you during these hours. If you have any inquiries or require support outside of these hours, please leave a voicemail, send an email, or use our online contact form. We will get back to you promptly during the next available support hours. Thank you for choosing Mirador Outdoor!

# DISASSEMBLY & DISPOSAL OF THE PRODUCT

**Incorrect disassembly of the pergola may lead to serious injury and product damage.**

**Disassembly should be assigned to qualified personnel with adequate training within the scope of occupational health and safety and knowledge within the scope of recycling.**

## **Disposal of used Electrical and Electronic Equipment**

When the service life of the product is over, it is necessary to disassemble it for disposal and to sort the individual materials and components in compliance with the local regulations of your country.

## **Important disposal information**

In compliance with European Directive 2012/19EU on waste electrical and electronic equipment (WEEE) it is forbidden to place the waste equipment marked with the crossed bin symbol with other waste to a container intended for domestic waste. Users wishing to dispose of electronic or electrical equipment are obliged to return it to a designated waste equipment collection point.

The above statutory obligations were introduced in order to limit the amount of waste generated from waste electrical and electronic equipment, and to ensure an appropriate level of collection, recovery and recycling. The equipment does not contain hazardous components which have a particularly adverse effect on the environment or human health.



## **Utilization of used batteries**

In compliance with the provisions of the Directive 2006/66/EC of the European Parliament and of the Council of 6 September 2006 on batteries and accumulators and waste batteries and accumulators and repealing Directive 91/157/EEC, the End User is obliged to transfer used portable batteries, which are no longer used as a source of energy, to an official collection point. It is forbidden to place used batteries with other waste in the same container. To prevent environmental pollution and causing a possible hazard for human and animal health, used batteries should be disposed of in the correct container at the designated collection points.

# CERTIFICATION INFORMATION

## ETL LISTED MARK

### **Conforms and Certified to standard Door, Drapery, Gate, Louver, and Window Operators and Systems [ANSI/CAN/UL 325:2017 Ed.7+R:28Feb2020]**

ETL is a Certification Program provided by Intertek, which is a Recognized Testing Laboratory (NRTL) in the United States , and is accredited by institutes and associations such as ANSI, A2LA, and UKAS.

The Mirador 111 SR e-Motion is ETL certified in the United States of America and Canada under Control Number 5026666.

**Manufacturer:**

Zhejiang Zhengte Co., Ltd.  
No.811, Oriental Ave, LINHAI CITY ZHEJIANG 317004, China.

**Documentation officer:**

Ziad Zhao  
Zhejiang Zhengte Co., Ltd.  
No.811, Oriental Ave, LINHAI CITY ZHEJIANG 317004, China.



# FCC INFORMATION



## Supplier's Declaration of Conformity Compliance Information

Unique Identifier	
Product Description	Mirador Pergola
Model Number	111R e-Motion S
Trade Name	Mirador
FCC Compliance Statement	
This device complies with part 15 of the FCC Rules. Operation is subject to the following two conditions: (1) This device may not cause harmful interference, and (2) this device must accept any interference received, including interference that may cause undesired operation.	
Responsible Party - U.S. Contact Information	
Company:	Sorara Outdoor Living USA, Inc.
Address:	290 Interstate N Cir SE Suite 150, Atlanta, GA 30339
Telephone or internet contact information:	909-597-5930 – Hello@Sorara.com

**Warning:** Any changes or modifications to this unit not expressly approved by the party responsible for compliance could void the user's authority to operate the equipment.

**Note:** This equipment has been tested and found to comply with the limits for a Class B digital device, pursuant to part 15 of the FCC Rules. These limits are designed to provide reasonable protection against harmful interference in a residential installation. This equipment generates uses and can radiate radio frequency energy and, if not installed and used in accordance with the instructions, may cause harmful interference to radio communications. However, there is no guarantee that interference will not occur in a particular installation. If this equipment does cause harmful interference to radio or television reception, which can be determined by turning the equipment off and on, the user is encouraged to try to correct the interference by one or more of the following measures:

- Reorient or relocate the receiving antenna.
- Increase the separation between the equipment and receiver.
- Connect the equipment into an outlet on a circuit different from that to which the receiver is connected.
- Consult the dealer or an experienced radio/TV technician for help.

### For Pergola:

#### MPE Requirements

To satisfy FCC RF exposure requirements, a separation distance of 20 cm or more should be maintained between the antenna of this device and persons during device operation.



To ensure compliance, operations at closer than this distance is not recommended.

### For remote control:

This equipment complies with FCC RF radiation exposure limits set forth for an uncontrolled environment. This device and its antenna must not be co-located or operating in conjunction with any other antenna or transmitter.

more to  
enjoy

FOLLOW US ON  
WWW.MIRADOROUTDOOR.COM

 @miradoroutdoor  @MiradorOutdoor  
 @miradoroutdoor  @miradoroutdoor



Printed on 100%  
post-consumer  
recycled paper

