

INSTRUCTION MANUAL ENCLOSED

ATTENTION

**IF YOU HAVE ANY PROBLEMS OR QUESTIONS, EMAIL OR CALL
CUSTOMER SERVICE BEFORE YOU RETURN THIS PRODUCT TO THE
STORE WHERE IT WAS PURCHASED.**

INSTRUCTION MANUAL ENCLOSED



Chaise Lounge

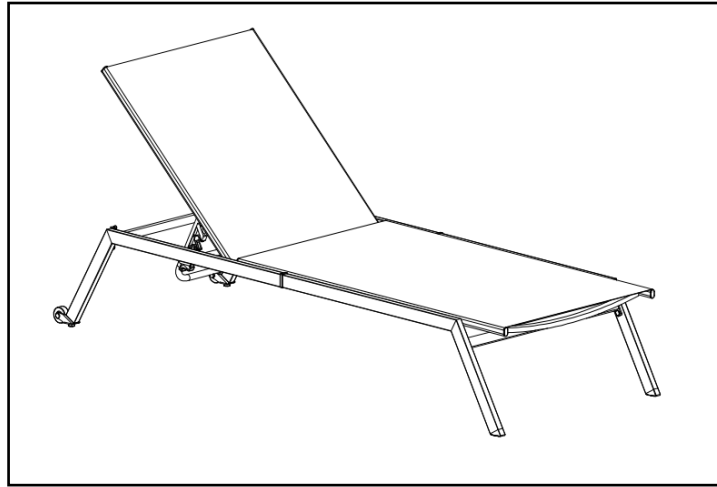

CHAISE LOUNGE ASSEMBLY INSTRUCTION



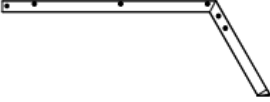
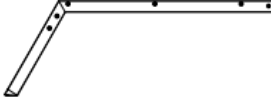



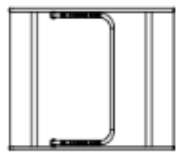



PARTS LIST



Part	Description	Quantity
<i>PARTS</i>		
AR	Chaise Lounge Leg (Right)	1
AL	Chaise Lounge Leg (Left)	1
BR	Wheeled Chaise Lounge Leg (Right)	1
BL	Wheeled Chaise Lounge Leg (Left)	1
C	Chaise Lounge Seat	1
D	Chaise Lounge Back	1
E	Support tube	1
F	Support tube	1
G	Support tube	1
H	Plastic part	2
<i>HARDWARE</i>		
I	M6x18mm	2
J	washer(M6)	24
K	M6x15mm	12
L	M6x25mm	10
M	M6x35mm	2
N	plastic end cap#1	28
O	plastic end cap#1	2
	Tool	1

AL	x1	AR	x1	BL	x1	BR	x1
							

C	x1	D	x1	E	x1	F	x1
							

G	x1	H	x2	I	x2	J	x24
							
		plastic part		M6x18mm		washer(M6)	

K	x12	L	x10	M	x2	N	x28
							
M6x15mm		M6x25mm		M6x35mm		plastic end cap#1	

O	x2	x1
		
plastic end cap#2		tool

PLEASE READ AND FOLLOW ALL SAFETY TIPS

GETTING STARTED

1. Before assembly, CAREFULLY use scissors or utility knife to cut and unwrap all parts. Make sure you do not discard the hardware.
2. Make sure that you have all the parts listed. If you are missing any parts, please contact Customer Service. Please identify the parts you need and model number. Make sure to include your name and address.

Warm Tips:

1. The plastic covers on some metal parts are just for product protection, Please remove it before assembly.
2. Please follow the sequence of AI during assembly.
3. Do not tighten the screws until all of them are in right positions.

Step 1 : Take off all the caps before assemble. Insert part BR to part AR with part H . Haft tighten the screws. Also insert part AL to part BL with part H . Haft tighten the screws up too.

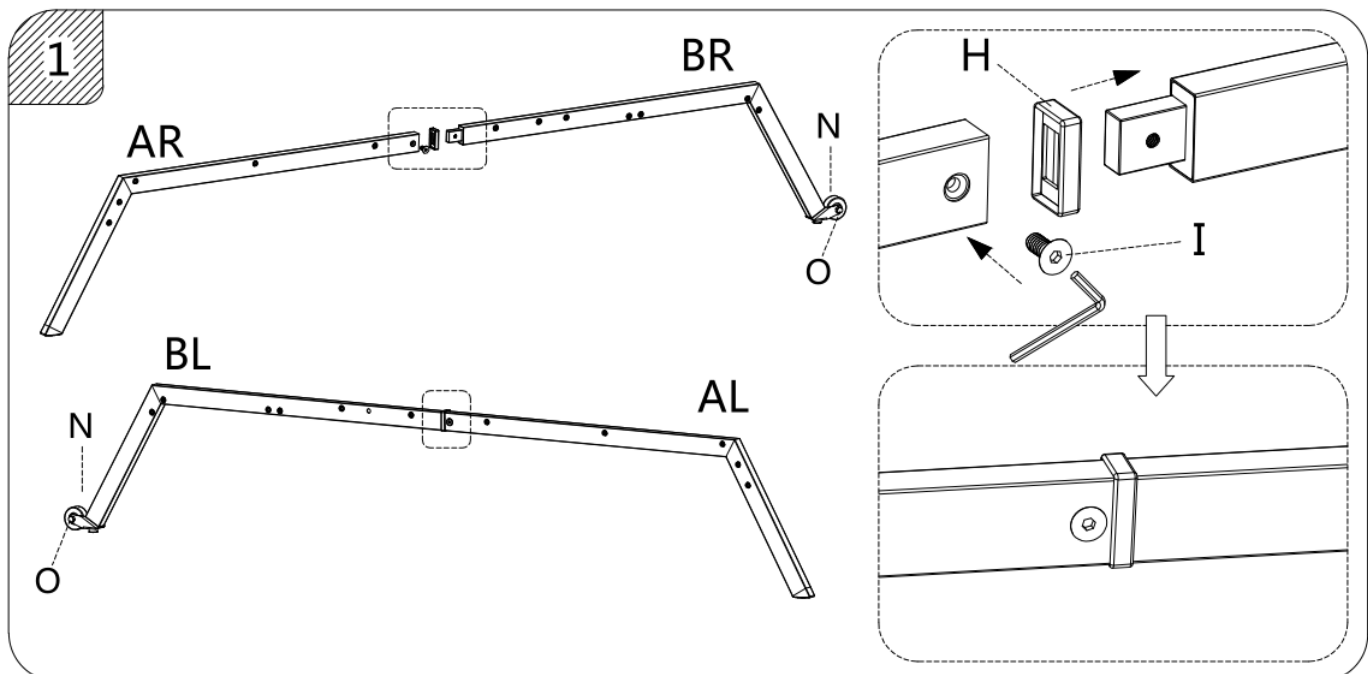
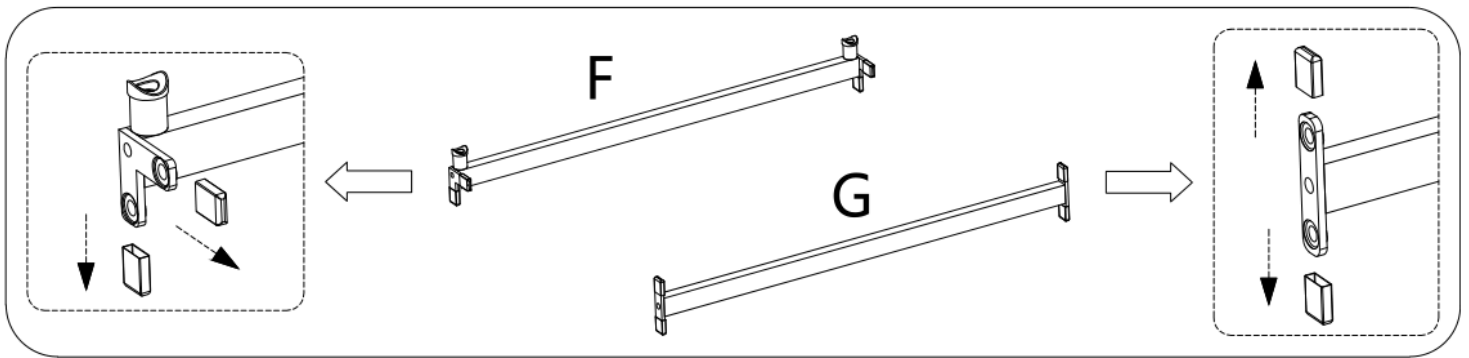

Step 2 : Place the whole right leg on soft place . Locate the Seat (part C) to the leg by aligning the pre-drilled holes . Do not tighten the screws . Locate the left leg to the Seat by aligning the pre-drilled holes . Haft tighten the screws with washers .

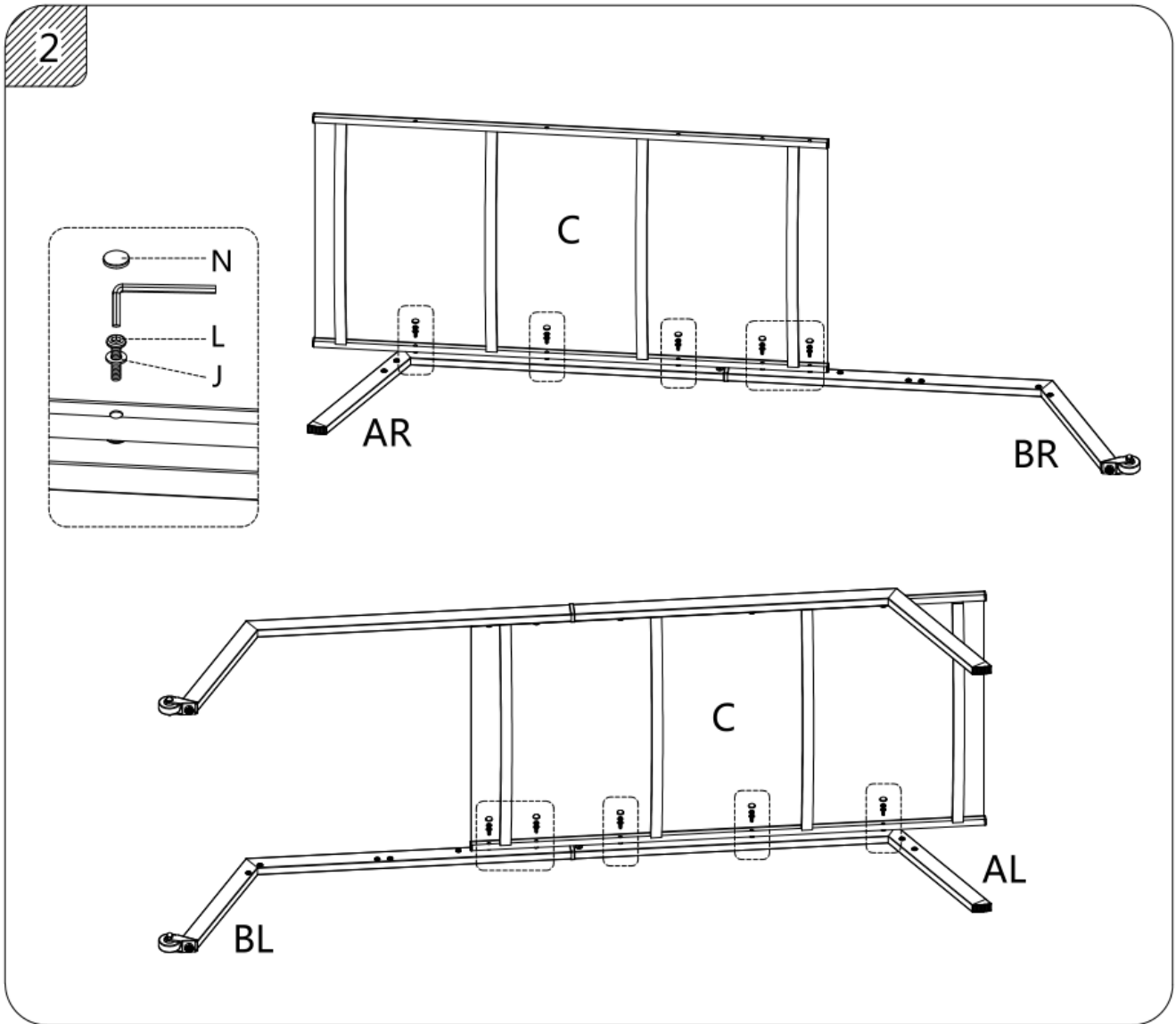

Step 3 : Locate the Back in the middle of two legs . Haft tighten the screws with washers.

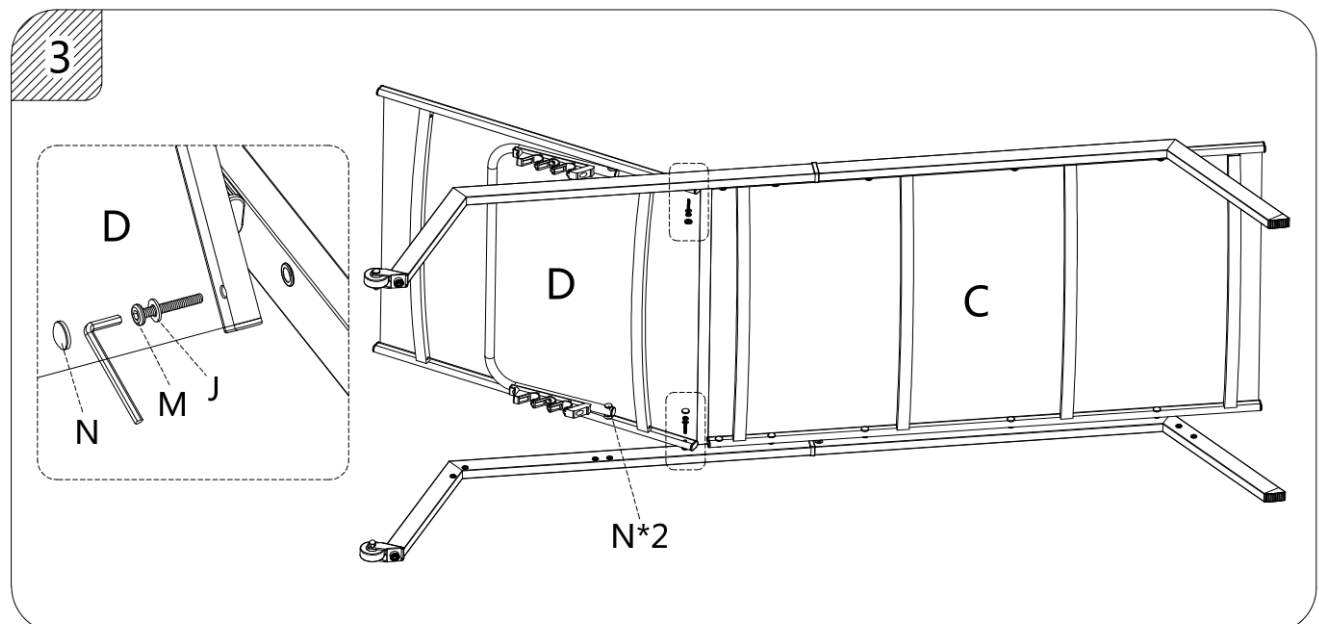

Step 4 : Locate the support tube (part E) by aligning the pre-drilled holes .Haft tighten the screws with washers .

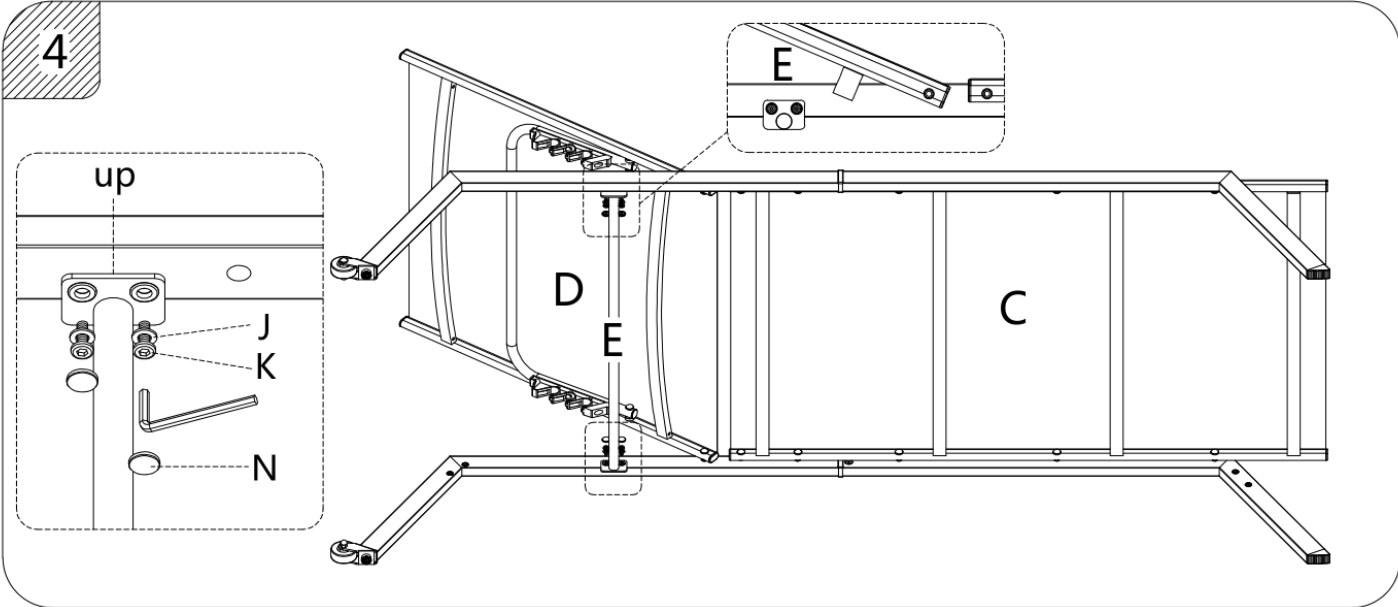

Step 5 : Locate the support tube (part F) by aligning the pre-drilled holes .Haft tighten the screws with washers .

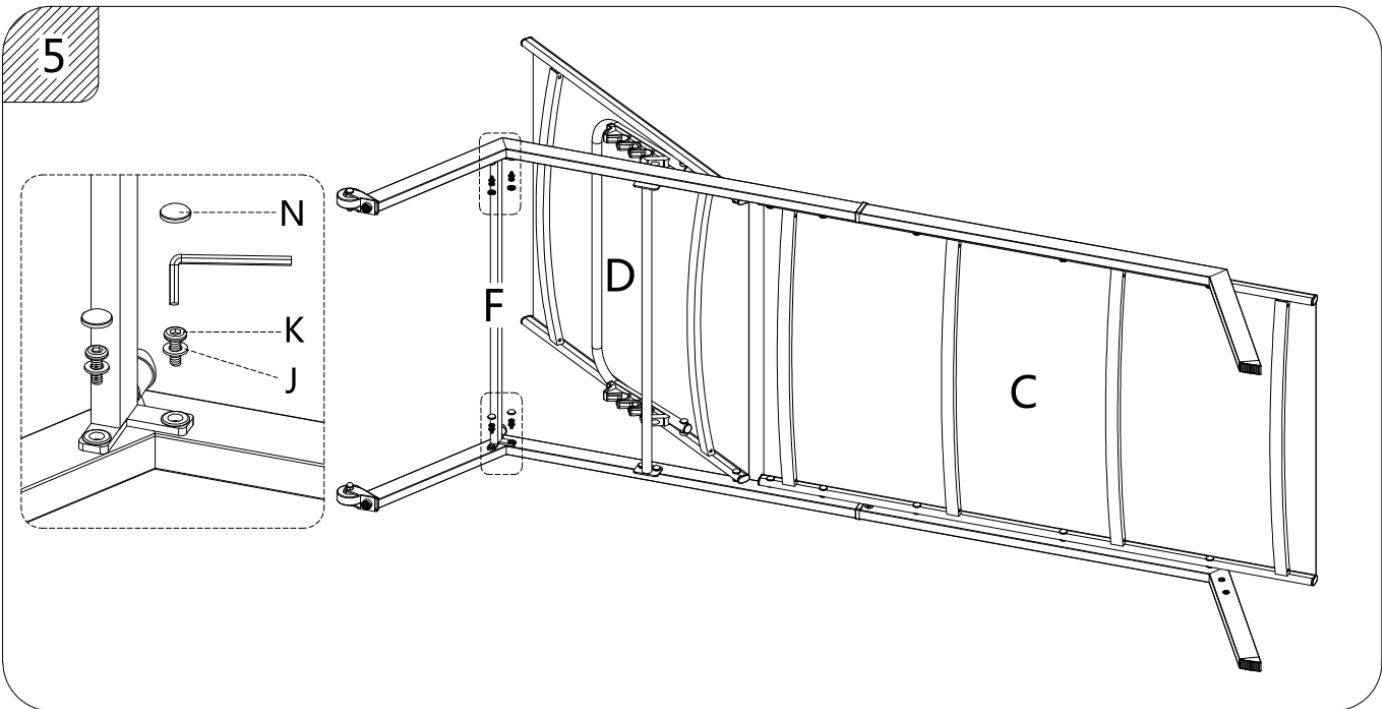

Step 6 : Locate the support tube (part G) by aligning the pre-drilled holes .Haft tighten the screws with washers .

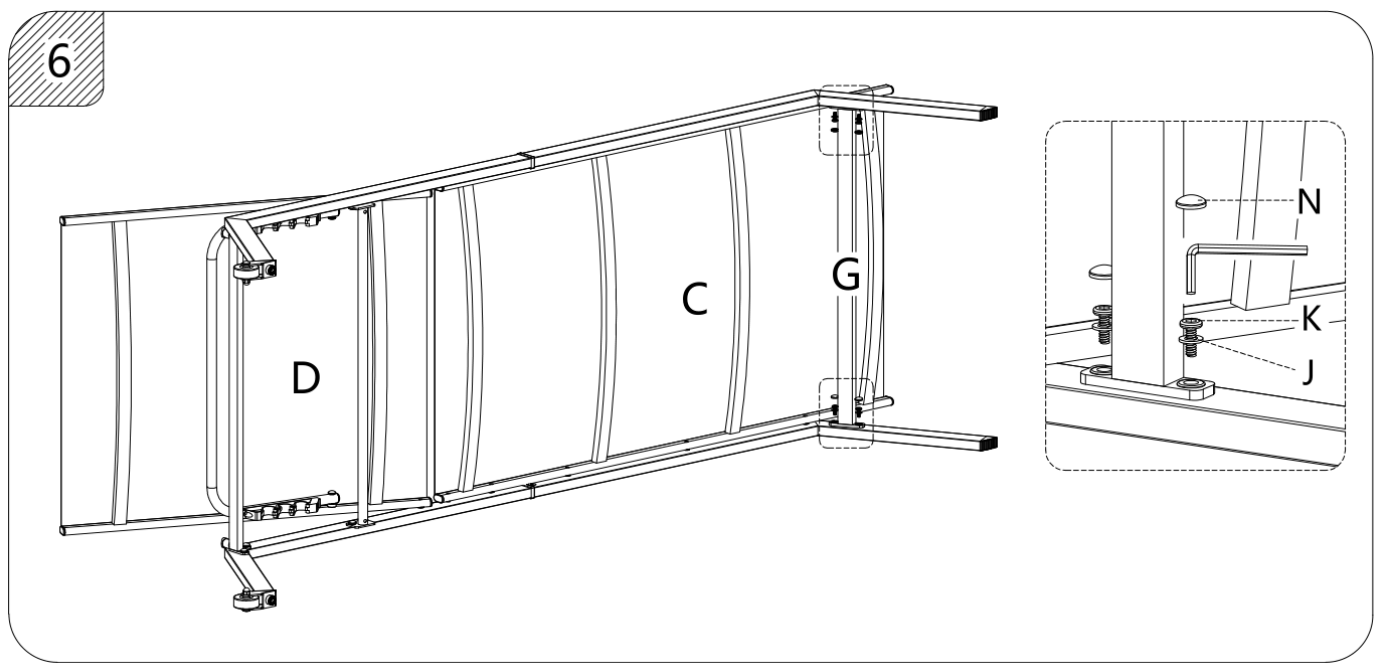

Tighten all the screws and then put the cap onto each screw . Till now you have finished the whole assembly.